



**Hydrogen Production Facility
STAMP Project Gateway**

**6840 Crosby Road
Alabama, New York 14013**

**STORMWATER POLLUTION PREVENTION PLAN
& DESIGN REPORT**

Owner/Applicant:

**Plug Power
968 Albany Shaker Road
Latham, NY 12110**

Date:

May 21, 2021



Prepared by:



**4759 N. 5th Street
Lewiston, NY 14092
1-716-946-2415**

TABLE OF CONTENTS

Stormwater Pollution Prevention Plan	1
I. Project Description	4
• Site Location Map	4
• Site Aerial Map	4
II. Description of Site Conditions and Utility Improvements	6
A. Soils Information	6
B. Wetlands	6
C. Archaeological and Historic Resources	7
D. Wildlife Habitat	8
E. Traffic and Access	8
F. Utilities	8
1. Water	8
2. Sanitary	9
3. Electrical	9
G. SEQRA	10
H. Stormwater Management	11
I. Existing Conditions	11
II. Proposed Conditions	12
• Water Quality Volume (WQv) and Green Infrastructure Techniques	14
• Runoff Reduction Volume (RRv)	15
• Stream Channel Protection Volume Requirements (CPv)	17
• Overbank Flood Control Criteria (Qp)	17

• Extreme Flood Control Criteria (Qf)	17
III. Erosion and Sediment Control	18
A. Temporary Erosion and Sediment Control Measures	18
B. Permanent Erosion and Sediment Control Measures	19
C. Sequence of Construction and Erosion Control Installation	20
D. Construction Waste Sites	21
IV. Inspections and Maintenance	24
A. General Construction Site Inspection and Maintenance Requirements	24
B. Contractor Maintenance Inspection Requirements	24
C. Qualified Inspector Inspection Requirements	25
V. Post-Construction Operation and Maintenance	28
VI. Additional Information	29
VII. Owner/Operator Certification Statement	33

APPENDICES

Appendix A Drainage Calculations

- A-1 Existing Conditions
- A-2 Proposed Conditions
- A-3 WQ_v, RR_v and Cp_v Calculations

Appendix B *New York State Department of Environmental Conservation SPDES General Permit for Stormwater Discharges from Construction Activity Permit No. GP-0-20-001.*

Appendix C Copy of Notice of Intent (eNOI) Form

Appendix D Blank copy of Notice of Termination (NOT) Form

Appendix E Contractor Certification Forms

Appendix F NYSDEC Phase II SPDES Permit Letter

Appendix G Soil Erosion & Sediment Control Details and Specifications

Appendix H Inspection Forms, Checklists and Maintenance Guidelines

Appendix I SEQR

Appendix J NYS Stormwater Management Design Manual Appendix H

Appendix K Stormwater Control Facility Maintenance Agreement

Appendix L Project Related Correspondence

Appendix M Project Drawings

**STORMWATER POLLUTION PREVENTION PLAN
(The Stormwater Management and Erosion Control Plan)
& Design Report**

This Stormwater Pollution Prevention Plan (SWPPP) & Design Report has been prepared to address construction activities associated with the site clearing, preparation, and construction of the Plug Power Hydrogen Production Facility (STAMP – Project Gateway) in the Town of Alabama, Genesee County, New York. The SWPPP, drainage design and Erosion & Sediment Control Plan have been prepared in conformance with the SPDES General Permit (GP-0-20-001) and the current NYS Standards and Specifications for Erosion and Sediment Control. This document is intended to be a dynamic document which will be amended, as necessary, to reflect any changes occurring as part of the construction process. This Stormwater Pollution Prevention Plan (hereafter to be called “The Plan”) has been prepared in conformance with the requirements set forth in the New York State Department of Environmental Conservation SPDES General Permit for Stormwater Discharges from Construction Activity Permit No. GP-0-20-001 (see Appendix B). The Plan addresses:

1. Impacts to surface water quality caused by soil erosion and sedimentation during construction and immediately following construction.
2. Post-construction increases in stormwater runoff.
3. Stormwater pollution caused by the use of the site after construction is complete.
4. Green Infrastructure per NYSDEC Phase 2 permit requirements.

The Plan must do the following:

Design, install and maintain effective erosion and sediment controls to *minimize* the *discharge* of *pollutants* and prevent a violation of the *water quality standards*. At a minimum, such controls must be designed, installed and maintained to:

- (i) *Minimize* soil erosion through application of runoff control and soil stabilization control measure to *minimize pollutant discharges*;
- (ii) Control stormwater *discharges*, including both peak flowrates and total stormwater volume, to *minimize* channel and streambank erosion and scour in the immediate vicinity of the *discharge* points;
- (iii) *Minimize* the amount of soil exposed during *construction activity*;
- (iv) *Minimize* the disturbance of *steep slopes*;
- (v) *Minimize* sediment *discharges* from the site;
- (vi) Provide and maintain natural buffers around surface waters, direct stormwater to vegetated areas and maximize stormwater infiltration to reduce *pollutant discharges*, unless *infeasible*;
- (vii) *Minimize* soil compaction. Minimizing soil compaction is not required where the intended function of a specific area of the site dictates that it be compacted; and
- (viii) Unless *infeasible*, preserve a sufficient amount of topsoil to complete soil restoration and establish a uniform, dense vegetative cover.

Plug Power Hydrogen Production Facility (STAMP Project Gateway)

May 21, 2021 Stormwater Pollution Prevention Plan & Design Report

(ix) *Minimize* dust. On areas of exposed soil, *minimize* dust through the appropriate application of water or other dust suppression techniques to control the generation of pollutants that could be discharged from the site.

A complete copy of The Plan shall be kept on site throughout the duration of the project.

The permittee is responsible to comply with the requirements and conditions as described in The Plan and in the *New York State Department of Environmental Conservation SPDES General Permit for Stormwater Discharges from Construction Activity* Permit No. GP-0-20-001.

A complete copy of The Plan includes the following items:

1. Drainage Calculations for the design of the stormwater management system - see Appendix A.
2. A copy of the *New York State Department of Environmental Conservation SPDES General Permit for Stormwater Discharges from Construction Activity* Permit No. GP-0-20-001 - see Appendix B.
3. A copy of the Notice of Intent - See Appendix C.
4. Contractor Certification Forms - see Appendix E.
5. Document referred to hereafter as the Project Drawings (see Appendix M for an 11" x 17" set):

Latest revision of the drawing set of construction plans (as filed with the Town of Alabama):

**Plug Power
Hydrogen Production Facility
STAMP Project Gateway
Alabama, New York 14013**

Prepared for:
Plug Power
968 Albany Shaker Road
Latham, New York 12110

The intent of The Plan is to:

- Provide background information about the scope of the project.
- Provide a statement of stormwater management objectives.
- Describe proposed structural and vegetative stormwater measures to ensure that the quantity, temporal distribution and quality of stormwater runoff during and after development are not substantially altered from pre-development conditions.
- Identify the type and frequency of maintenance required by the stormwater management and erosion control facilities utilized.

Owner/Operator Contact Information:

Company: Plug Power
Contact Person: Brenor Brophy
Vice-President, Project Development
Mailing Address: 968 Albany Shaker Road
Latham, NY 12110
Email Address: brbrophy@plugpower.com
Phone Number: (408) 823-6566

Engineer of Record Information:

Firm: Invictus Civil Engineering, P.C.
Contact Person: Richard J. Haight, P.E.
Mailing Address: 4759 N. 5th Street
Lewiston, New York 14092
Email Address: rhaight@invictuscivilengineering.com
Phone Number: (716) 946-2415

I. PROJECT DESCRIPTION

The Plug Power Hydrogen Production Facility Project (STAMP Project Gateway) is located at 6840 Crosby Road on a 29.096+/- acre parcel (excluding R.O.W.) within the Science & Technology Advanced Manufacturing Park (STAMP) in the Town of Alabama (See Site Location Map and Site Aerial Map below:). The Parcel is illustrated as Proposed Parcel "A", a portion of Liber 428 page 880, a portion of SBL 10-1-42 on the boundary survey for the parcel (See Appendix M - Project Drawings). The GCEDC is the current owner of the parcel but is in the final stages of closing the sale of the site to Plug Power. A copy of correspondence from GCEDC authorizing Plug Power (and their agent) to proceed through the Town of Alabama and Genesee County Planning Board Site Plan Submission and Approval process can be found in Appendix L - Project Related Correspondence.



Site Location Map

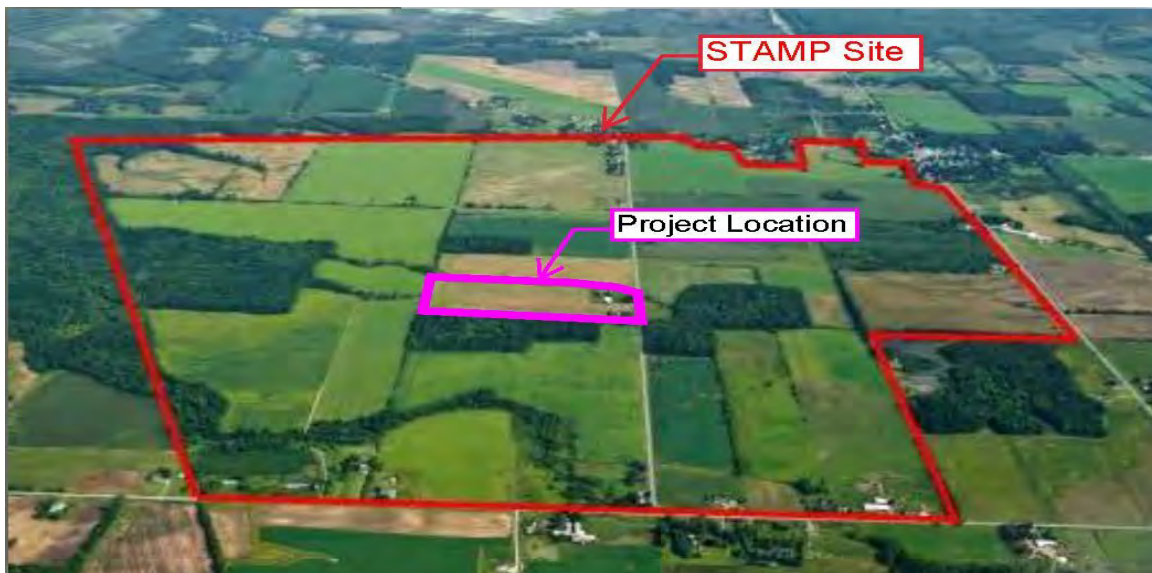

Site Aerial Map

Plug Power Hydrogen Production Facility (STAMP Project Gateway)

May 21, 2021 Stormwater Pollution Prevention Plan & Design Report

The STAMP project was initiated in 2005 and the overall STAMP site was selected based on an 18-month review of alternatives in Genesee County. A thorough evaluation of Site background, history, cultural and natural resources, utilities, and region has been conducted by the Genesee County Economic Development Corporation (GCEDC) as detailed in their STAMP Land Management Plan. Technical studies and analysis were utilized to optimize site design and minimize adverse impacts to sensitive resources. The potential environmental impacts of STAMP were evaluated pursuant to, and in accordance with, Article 8 of the Environmental Conservation Law and the regulations adopted pursuant thereto being 6 NYCRR Part 617, as amended (collectively State Environmental Quality Review or SEQR) utilizing a Generic Environmental Impact Statement (GEIS). The GCEDC, as lead agency, issued a Final GEIS (FGEIS) for the Project on January 19, 2012 and a Written Findings Statement (GCEDC's Findings) on March 12, 2012. The Town of Alabama issued an Involved Agency Findings Statement on August 13, 2012. As lead agency, the GCEDC conducted an updated SEQR analysis to review proposed changes to STAMP since completion of the GEIS. Based on this review, a Lead Agency Amended Findings Statement was issued by GCEDC in July 2016.

The STAMP Site was rezoned as a Technology District (TD) broken down into three sub-districts, TD1, TD2 and TD3, each of which has its own set of permitted uses under the Town Code. The Plug Power Hydrogen Production Facility will be located in the TD1 District which is the primary heavy manufacturing/industrial district.

The Plug Power Hydrogen Production Facility Project will be the construction of an 80 ton-per-day green hydrogen production facility, built in two phases. The hydrogen is produced by electrolysis using clean hydropower. The process produces no pollution and creates essentially no waste. Phase 1 of the facility will include an approximately 40,040 sq-ft electrolyzer building housing the hydrogen production equipment, a 68,153+/_ sq. ft. compressor/liquefaction building with control room which will house compressors, cold-boxes and re-liquefaction units, and an approximately 8,125 sq-ft operations and maintenance building containing office space, a conference room, facility restrooms, employee breakroom and maintenance shop. Additional equipment located outside includes cooling units, electrical transformers & cabinets, an electrical substation, tanks, pumps, and a filling facility for transport tankers that pick up the liquid hydrogen product for delivery. There will be a 22-space parking lot adjacent to the O & M Building for employees. In addition, staging areas will be established for truck trailer parking with space for 28 trailers. Phase 2 of the facility will include an approximately 26,260 sq-ft electrolyzer building for the hydrogen production equipment and a 40,200+/_ sq. ft. compressor/liquefaction building with control room which will again house compressors, cold-boxes and re-liquefaction units. Phase 2 starts after phase 1 commissioning.

Plug Power Hydrogen Production Facility (STAMP Project Gateway)

May 21, 2021 Stormwater Pollution Prevention Plan & Design Report

II. DESCRIPTION OF SITE CONDITIONS AND UTILITY IMPROVEMENTS

Note: See the Project Drawings for additional information on site conditions

The site has historically been used in the production of agricultural crops along with supporting farm structures and residences.

A. SOILS INFORMATION

There are five (5) soil types within the project site:

Canandaigua silt loam, 0 - 2% slopes 6.7% (CaA - Hydrologic Soil Group "C/D")

Collamer silt loam, 2 - 6% slopes 2.9% (ClB - Hydrologic Soil Group "C/D")

Lakemont silty clay loam, 0 - 3% slopes 7.0% (La - Hydrologic Soil Group "D")

Niagara silt loam, 0 - 2% slopes 1.4% (NgA - Hydrologic Soil Group "C/D")

Odessa silt loam, 3 - 8% slopes 64.7% (OdB - Hydrologic Soil Group "D")

Hydrologic Soil Group "D" has been used in the hydraulic analysis for all areas of the site as a conservative estimate.

See Appendix A - Drainage Calculations for a copy of the soil survey map and soils information obtained from the USDA Natural Resources Conservation Service Web Soil Survey National Cooperative Soil Survey.

B. WETLANDS

As indicated in Figure 7 below from GCEDC's Land Management Plan, the project site is bounded by USACOE Wetlands within a tributary along the north property line of the site, Wetlands on the property to the south and a Wetland finger to the west. The primary functions and values provided by wetlands at the STAMP Site include flood-flow alteration, nutrient removal/retention/transformation, sediment/toxicant retention, and wildlife habitat. The Plug Power Hydrogen Production Facility will not disturb any of the Wetlands. A 25' wide Conservation Buffer Area will be maintained along the northern limits of the site along the tributary Wetland.

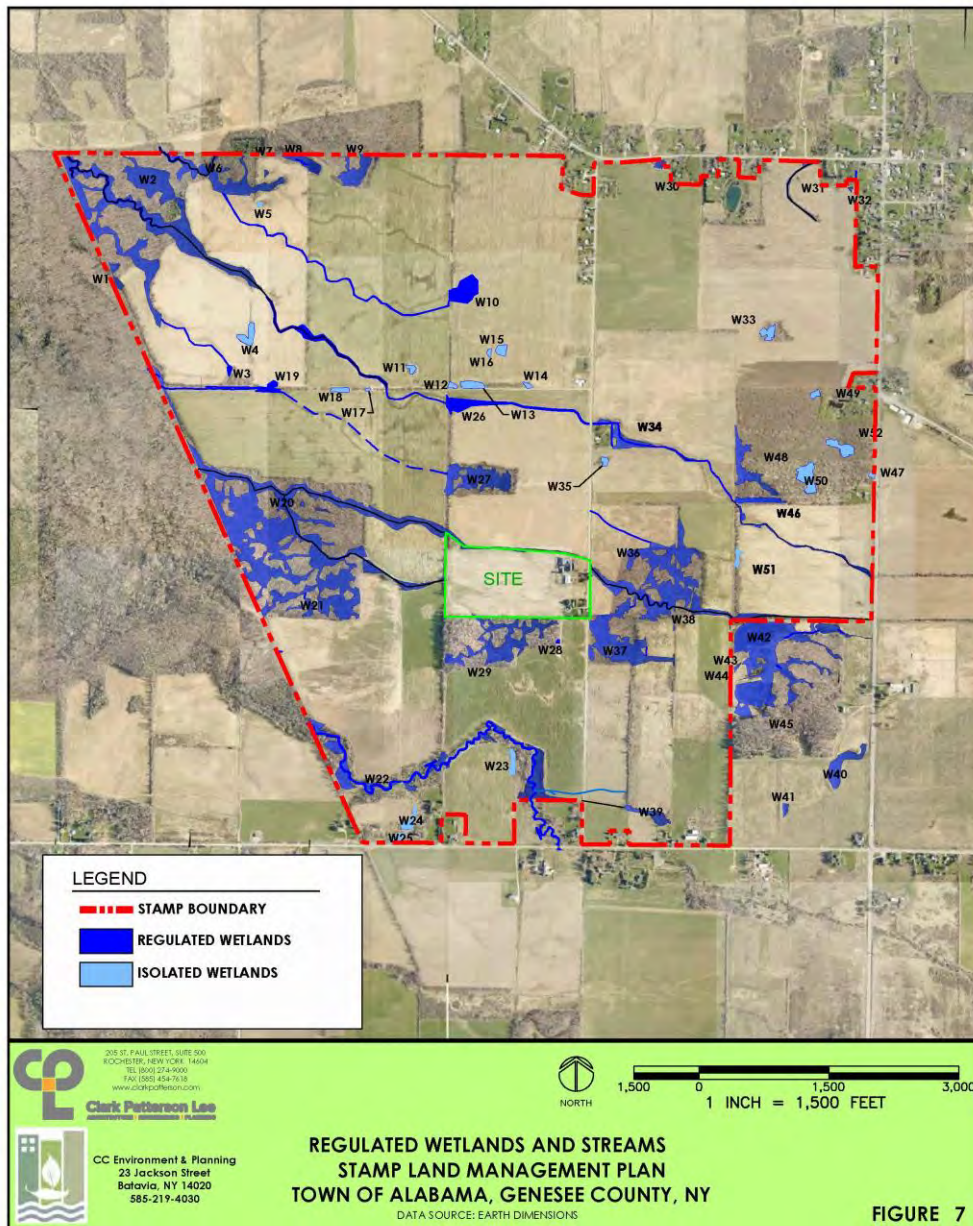

C. ARCHAEOLOGICAL AND HISTORIC RESOURCES

As indicated in GCEDC’s LMP and Amended SEQR Findings Statement, Cultural resource investigations were completed for the STAMP Site by Deuel Archaeology & CRM in 2010 and by the Archaeological Survey, Department of Anthropology at the State University of New York at Buffalo in 2013 and 2016. A Phase 1B Archaeological Investigation has been completed on the subject parcel which has been fully cleared. See Appendix I for Archaeological Investigation Mapping and Findings from Appendix D of the GCEDC LMP.

Plug Power Hydrogen Production Facility (STAMP Project Gateway)

May 21, 2021 Stormwater Pollution Prevention Plan & Design Report

D. WILDLIFE HABITAT

The Plug Power Hydrogen Production Facility will be located on a parcel which is primarily utilized in agricultural production and has some perimeter shrub, forest and wetland habitat. These communities are not considered rare habitats. According to the GCEDC LMP, a Phase I Summer Habitat Assessment was completed for the northern long-eared bat, which has recently been listed as a Threatened Species under State and Federal Law. As indicated in the GCEDC Amended Findings Statement, removal of trees greater than 3" DBH will be prohibited between June 1 and July 31, as well as between October 31 and March 31, where possible. There will be limited clearing of treed areas on the Project site and therefore no adverse impact to the northern long-eared bat.

E. TRAFFIC AND ACCESS

A boulevard entry and new access road (STAMP Drive) has been constructed by GCEDC from NYS Route 77/63 to Crosby Road at the heart of the STAMP campus. The Project Site is located to the south on Crosby Road. Crosby Road is currently a local roadway serving residential and agricultural properties. The GCEDC will be reconstructing the portion of Crosby Road from STAMP Drive to the site to accommodate industrial vehicles.

Access to the site will be provided via a 30' driveway which will narrow to 26' within the site. A looped roadway will be provided around the perimeter of the Facility, as well as a 26' wide internal Fire Access connecting drive.

Traffic generated by the site is anticipated to be relatively low, consisting of approximately 20 employees and 16 tanker trucks per day.

F. UTILITIES

1. Water:

The STAMP Site consists of agricultural land and a few residential houses that do not contain municipal water service or fire protection and are served by private wells. As part of the development of the STAMP campus, the GCEDC will be constructing a new 12" transmission water main. The water main will extend from the Village of Oakfield existing water system located approximately seven miles to the east along NYS Route 63 to Routes 77/63 and into the STAMP Site. The GCEDC will be extending the 12" water main down Crosby Road to service the Plug Power Hydrogen Production Facility.

Water modeling for the new water main indicates the following available pressure and fire flow at the Crosby Road site:

- Pressure at Crosby Road: +/- 98 psi
- Fire Flow at Crosby Road: +/- 1,698 gpm

Anticipated demand from the Facility is 280,000 gpd. A new 10" PVC water line will be constructed into the site of the Crosby Road main. Once on the site, the flow will be split prior to entering a hot box to provide an 8" PVC fire protection line and a 10" Process/Domestic water line. A double check valve will be provided within the hot box for the fire protection line, while a meter and RPZ backflow preventor will be installed within the hot box for the Process/Domestic line.

The Fire Protection line will loop around the exterior of the internal roadway, with hydrants installed periodically within 500' of each other.

A 2" Type K copper service will be provided to the site's O & M Building off the Process/Domestic line. The Process/Domestic line will run down the south side of the Fire Access drive to service the remainder of the Facility.

2. Sanitary:

The STAMP Site does not contain municipal sanitary sewer service. The closest municipal wastewater treatment facilities are in the Villages of Oakfield and Corfu (approximately 9 miles from the Site). The GCEDC is currently designing wastewater facilities to service the Plug Power Hydrogen Production Facility.

The Facility is anticipated to produce approximately 500 gpd of domestic sanitary flow from bathroom facilities within the site. The domestic discharge will be via a 6" PVC SDR-35 sanitary lateral along the southern limits of the site.

Approximately 70,000 gpd of Process Wastewater is anticipated from the Facility. The Process Wastewater will discharge the site via a 10" CPVC sewer main running parallel and offset from the Process/Domestic water feed along the Fire Access drive for the facility. The discharge pass through a Flume/Meter pit prior to exiting the site and entering the municipal system to be constructed by the GCEDC.

3. Electrical:

The STAMP Site lies within the Niagara Hydro Power Zone, which has the potential to provide a low-cost, renewable source of energy for users at the Site. A 115 kV line currently traverses the Site. A 345 kV line is located just north of STAMP. GCEDC is working with National Grid on the process of establishing a

new substation for the STAMP site for conversion to 115kV which will service the Plug Power Hydrogen Production Facility.

A new substation for the Facility is currently under design for conversion to 69kV and will be located at the northeast corner of the site. Estimated annual electrical demand for the Facility is 225 MW under Full-Build conditions.

G. SEQRA

The STAMP site went through the SEQRA process pursuant to the New York State Environmental Quality Review Act, Article 8 of the Environmental Conservation Law and the regulations promulgated thereto at 6 N.Y.C.R.R. Part 617 with the Genesee County Industrial Development Agency d/b/a the Genesee County Economic Development Corporation ("GCEDC") as Lead Agency. A generic environmental impact statement consisting of the Draft Generic Environmental Impact Statement ("DGEIS") accepted by the GCEDC on April 14, 2011, the Final Generic Environmental Impact Statement ("FGEIS") accepted by the GCEDC on January 19, 2012, as well as the public comments on the DGEIS received at the May 12, 2011 public hearing and during the public comment period which was conducted from April 21, 2011 through June 23, 2011. A smart growth impact statement pursuant to the State Smart Growth Public Infrastructure Policy Act was completed separately from the GEIS in February 2012. The GCEDC, as lead agency, issued a written Findings Statement ("GCEDC Findings") on March 12, 2012 approving the Project and committing to undertake it. An Amended Findings Statement was issued in July, 2016. A copy of the Amended Findings Statement can be found in Appendix I - SEQR.

Plug Power submitted a long form EAF dated December 30, 2020 to the GCEDC, as Lead Agency for the original Environmental Impact Study (EIS). At their February 4, 2021 meeting, the GCEDC voted unanimously to adopt the Resolution No. 02/2021 - 02 indicating that "there are no significant adverse environmental impacts that would be created by this project that had not previously been analyzed. No mitigation is necessary if Project Gateway commits to the best practices outlined in the EIS". A copy of the Plug Power Hydrogen Production Facility (STAMP - Project Gateway) EAF, along with the GCEDC February 4, 2021 Meeting Minutes can be found in Appendix I - SEQR.

H. STORMWATER MANAGEMENT

I. Existing Conditions:

The existing site drains predominantly in a west/northwesterly direction toward either to the northern Wetland Tributary or the western Wetland Finger. A small portion along the southerly limits of the site drains overland to the south to the adjacent Wetland. The site can be broken into the following four (4) drainage areas:

Area Overland to Southwest Property Line (Wetland): The stormwater runoff from approximately 1.16 acres of the southwestern portion of the site drains overland to the south property line and off-site to the adjacent Wetland.

Area Overland to Southeast Property Line: Approximately 0.49 acres at the extreme southeastern corner of the site drains overland to the south property line and off-site.

Area Overland to West Property Line (Wetland): Approximately 6.50 acres of the existing site drain overland in a westerly direction to the west property line where it leaves the site and enters the adjacent Wetland finger.

Area Overland to North Property Line Tributary (Wetland): The majority of the existing site (21.66+/- acres) drains in a northerly direction to the Tributary (Wetland) along the north property line of the site. The tributary carries flow from the east side of Crosby Lane to the west to a Wetland area. This area includes flow from the site frontage that is carried to the north and the Tributary by the Crosby Road roadside ditch.

See Appendix A-1 - Existing Conditions Drainage Calculations - for the Existing Conditions Drainage Map.

II. Proposed Conditions:

Under the proposed conditions, the four drainage areas will remain, but will be modified as follows:

Area Overland to Southwest Property Line (Wetland): The contributing area for stormwater runoff off-site to the adjacent Wetland along the southwestern portion of the site will be reduced to 0.59+/- acres. The area will continue to drain overland and will not contain any impervious cover.

Area Overland to Southeast Property Line: The contributing area draining overland at the extreme southeastern corner of the site to the south property line and off-site will be reduced to approximately 0.29 acres. The area will also not contain any impervious cover.

Area Overland to West Property Line (Wetland): Approximately 0.88 acres of the original 6.50+/- contributing acres of the site will continue to drain overland in a westerly direction to the west property line where it leaves the site and enters the adjacent Wetland finger. The area will not contain any impervious cover, as well.

Area Overland to North Property Line Tributary (Wetland): Stormwater runoff from the vast majority of the proposed site (27.35+/- acres) will be directed to the Tributary (Wetland) along the north property line of the site. Within the site, the stormwater runoff will either be collected by a series of storm drainage inlets and piped to, or drain overland to the gravel area surrounding the Electrolyzer Building and supporting mechanical equipment. A perforated pipe system will be constructed along the perimeter of the inside of the loop road/fire access drive. The subgrade will be pitched to drain to the perimeter perforated pipe system. A portion of the gravel area will be utilized for stormwater storage for the larger storm events. Three discharge pipes will be installed to direct the low flow (one-year) storm event to a 50,275+/- sq.ft. Bio-Retention Area at the northwest corner of the site via vegetated swales. Three additional discharge pipes will be installed above the one-year storm storage elevation to discharge the larger storm events to a Vegetated Dry Detention Pond, also via vegetated swales. Both the bio-retention area and the vegetated dry detention pond will discharge through multiple outlets to the Tributary Wetland along the north property line of the site.

See Appendix A-2 - Proposed Conditions Drainage Calculations - for the Proposed Conditions Drainage Map.

Water quantity controls will be provided by the subsurface detention provided by the gravel area around the Electrolyzer Building and the vegetated dry detention pond. Water quality controls will be provided the bio-retention area.

The following table indicates a composite summary of the site discharges to the four (4) design points under the Existing and Proposed (Full Build) conditions for the 1, 10, 25 and 100-year design storms, as well as a total peak site discharge. There will be no increase in peak discharge from the site. In addition, the Town of Alabama requires the stormwater management design to detain the difference between the 10-year pre-developed storm and the 25-year post-developed storm. The table indicates that the requirement has been met.

Design Point	Design Storm							
	1-year		10-year		25-year		100-year	
	Exist. Q_{peak} (cfs)	Prop. (Full Build) Q_{peak} (cfs)	Exist. Q_{peak} (cfs)	Prop. (Full Build) Q_{peak} (cfs)	Exist. Q_{peak} (cfs)	Prop. (Full Build) Q_{peak} (cfs)	Exist. Q_{peak} (cfs)	Prop. (Full Build) Q_{peak} (cfs)
Area to SW Prop. Line	0.79	0.22	2.13	0.73	2.94	1.06	4.58	0.76
Area to SE Prop. Line	0.19	0.11	0.60	0.37	0.87	0.53	1.41	0.38
Area to W. Prop. Line	3.27	0.35	8.32	1.14	11.32	1.64	17.29	1.22
Area to N. Prop. Line Tributary (NW corner of site)	6.98	1.75	19.79	13.22	27.94	18.60	44.19	33.06
* Total Peak Site Discharge	9.40	1.87	26.71	13.50	37.34	19.06	58.95	34.12

* The Peak Site Discharge is not a cumulative total of the peak flows from the various drainage areas but is based on the relationship of the various times to peak for the drainage areas within the site.

A ten-year design recurrence has been used as design criteria for storm system sizing for the site; however, the stormwater management practices have been designed to contain the 100-year storm event. The Project Drawings depict the grading and drainage improvements for the site. A copy of the hydraulic analyses can be found in Appendix A - Drainage Calculations.

The bio-retention area and vegetated dry detention pond will be constructed by Plug Power. Upon completion of construction, Plug Power will assume the responsibility and maintenance for site's stormwater management system.

The completed Notice of Intent, along with a copy of this SWPPP document will be submitted to the NYSDEC for Permit Coverage under GP-0-20-001. (See Appendix C). An Erosion and Sediment Control Plan has been prepared for the site (See Appendix M - Project Drawings). This SWPPP document and the Erosion and Sediment Control Plan have been developed in conformance with the current NYS Standards and Specifications for Erosion and Sediment Control (aka Blue Book).

- **WATER QUALITY VOLUME (WQ_v) and GREEN INFRASTRUCTURE TECHNIQUES**

The Plug Power Hydrogen Production Facility project falls under the New Development Guidelines of the N.Y.S.D.E.C., which apply to the increase in impervious cover on the site.

The New York State Stormwater Management Design Manual requires the incorporation of green infrastructure techniques and standard stormwater management practices (SMPs) with Runoff Reduction Volume (RR_v) capacity. The Manual requires that Green Infrastructure techniques be incorporated in the site design to allow for micromanagement of runoff, promote groundwater recharge, increase losses through evapotranspiration and emulate the preconstruction hydrology, resulting in reduced water quality treatment volume and thereby providing a Runoff Reduction Volume (RR_v). (See below for RR_v requirements.) Green Infrastructure techniques utilize the natural features of the site and promote runoff reduction.

The WQ_v for the development (15.513+/- ac. of impervious cover within the 25.013+/- contributing drainage area) has been calculated to be 1.267 ac-ft. (see Appendix A - Drainage Calculations - A-3 for the WQ_v calculations).

By utilizing a Bio-Retention Area (standard SMP with runoff reduction capacity), the Green Infrastructure requirements can be met. A Bio-retention area constructed with a planting soil bed, mulch layer and surface ponding area, along with an underdrain, will be utilized to provide a portion of peak flow attenuation, filter flow and promote infiltration. In order to meet the minimum WQ_v requirements, 50,174 sq.ft. of bio-retention area must be provided (see Appendix A - Drainage Calculations). By constructing an 50,275 sq.ft. of bio-retention area, 1.270 ac-ft of WQ_v will be provided.

- **RUNOFF REDUCTION VOLUME (RR_v)**

The current NYSDEC Stormwater Management Design Manual (Manual) was adopted in January, 2015 and addresses stormwater runoff reduction and provides planning, design and implementation of green infrastructure techniques for New Construction. (According to Chapter 9, Section 9.2B.II of the Manual, although encouraged, meeting the Runoff Reduction Volume (RR_v) sizing criteria is not required for the Redevelopment activity portion of the project.) The regulations are intended to control the quality and flow-rate of stormwater runoff from a developed site and to control the volume of runoff from a developed site (runoff reduction). The Manual promotes that the runoff reduction requirement is to be achieved through the use of re-use and infiltration of the runoff. The Manual requires the incorporation of green infrastructure techniques and standard stormwater management practices (SMPs) with Runoff Reduction Volume (RR_v) capacity.

Ten Green Infrastructure Techniques are allowed by the N.Y.S.D.E.C. Stormwater Management Design Manual to provide the required RR_v, as follows:

1. Conservation of Natural Areas
2. Sheetflow to Riparian Buffers or Filter Strips
3. Vegetated Swale
4. Tree Planting/Tree Pit
5. Stream Daylighting
6. Rain Gardens
7. Green Roofs
8. Stormwater Planters
9. Rain Barrels and Cisterns
10. Porous Pavement

Each of these Techniques has been reviewed for implementation at the site with the following results:

1. Conservation of Natural Areas

The majority of the site is utilized in agricultural crop production; however, a 25' wide Conservation Buffer will be maintained along the northern property line along the Tributary Wetland.

2. Sheetflow to Riparian Buffers or Filter Strips

Vegetated drainage areas along the perimeter of the site will be allowed to continue to drain overland to the adjacent Wetland areas.

3. Vegetated Swale

Vegetated swales will be utilized for pre-treatment of runoff to the bio-retention area and vegetated dry detention pond. They will not be used to meet WQv requirements since there is only a 10% runoff reduction of the WQv allowed by the practice for HSG D soils.

4. Tree Planting/Tree Pit

The runoff reduction for tree planting is limited to the pervious area in which the trees are planted. The project is not conducive to this technique.

5. Stream Daylighting

There are no previously culverted/piped streams on the site.

6. Rain Gardens

This technique cannot be used for infiltration when used in HSG D soils and must have an underdrain and an overflow for larger storm events, both connected to a conveyance system (storm sewer). Runoff reduction in poor soils is limited to 40% of the WQv for the contributing area. A bio-retention area is proposed for the site.

7. Green Roofs

The project is not conducive to this technique.

8. Stormwater Planters

This technique is used for filtration only in poor soils and must have an underdrain system and overflow connected to a conveyance system (storm sewer). The technique is geared toward urban sites. This project is not conducive to stormwater planters.

9. Rain Barrels and Cisterns

Overflow discharge must be provided and operation during cold weather conditions is difficult. There must be a use for the captured water. This project is not conducive to rain barrels or cisterns.

10. Porous Pavement

Porous pavement on poor soils cannot be utilized for infiltration and must have an underdrain system connected to a conveyance system (storm sewer). There are no advantages for using porous pavement on this project.

The Runoff Reduction volume for the increase in impervious cover (15.227+/- ac.) at the site has been calculated to be 0.241 ac-ft. (see Appendix A-3 - Drainage Calculations for RRv calculations). According to Table 3.5 in the NYS Stormwater Management Design Manual (the Manual), a bio-retention practice can utilize 40% of the WQv provided by the practice towards meeting the RRv requirement. Therefore, a RRv of 0.508 ac-ft will be provided by the bio-retention area (0.40 x 1.270 ac-ft).

- **STREAM CHANNEL PROTECTION VOLUME REQUIREMENTS (C_p)**

Stream Channel Protection Volume Requirements (C_p) are designed to protect stream channels from erosion. In New York State this goal is accomplished by providing 24-hour extended detention of the one-year, 24-hour storm event.

According to Section 9.2-A-II of the Manual, Stream Channel Protection Volume Requirements are not required for redevelopment activities if there are no changes to hydrology that increase the discharge rate from the project site. Therefore, providing 24-hour detention of the 1-year storm to meet the channel protection criteria is required for the project.

The C_p requirement for the project has been calculated to be 0.741 ac-ft (See Appendix A - Drainage Calculations - A-3 for C_p calculations). By utilizing the gravel area around the Electrolyzer Building and a Bio-retention area, a CPv of 1.214 ac-ft will be provided.

- **OVERBANK FLOOD CONTROL CRITERIA (Q_p)**

Overbank Flood Control requires storage to attenuate the post development 10-year, 24-hour peak discharge rate (Q_p) to predevelopment rates. The site discharges meet this requirement - see tables above and Appendix A - Drainage Calculations.

- **EXTREME FLOOD CONTROL CRITERIA (Q_f)**

Extreme Flood Control requires storage to attenuate the post development 100-year, 24-hour peak discharge rate (Q_f) to predevelopment rates. The proposed site discharges meet this requirement - see tables above and Appendix A - Drainage Calculations.

Both the Q_p and Q_f requirements have been met through detaining flow onsite within gravel area around the Electrolyzer Building, in the Bio-retention area and in the Vegetated Dry Detention Pond, thereby increasing the time the flow is on site.

III. EROSION AND SEDIMENT CONTROL

An Erosion and Sediment Control Plan in conformance with the SPDES General Permit (GP-0-20-001) and the current NYS Standards and Specifications for Erosion and Sediment Control has been prepared for the project. A copy of the plan can be found in Appendix M - Project Drawings

A. Temporary Erosion and Sediment Control Measures

The temporary erosion and sediment control measures that will be implemented are described below. The anticipated locations of these temporary measures are indicated on the Project Drawings. The quantity and location(s) of the erosion and sediment control measures will be finalized with the Permittee and/or Contractor prior to the start of construction and will be modified as field conditions and construction activities warrant. The Permittee and/or Contractor shall be responsible for implementation and maintenance of all required sediment control measures as described in The Plan. All erosion and sediment control measures are to be installed as specified in The Plan and the project details. The details and specifications for materials, sizing and installation requirements can be found in Appendix G and on the Project Drawings.

- Stabilized Construction Entrance (CE) - Construction vehicles will enter and exit the site via a stabilized construction entrance to be located at the proposed driveway intersection with Crosby Road. A stabilized construction entrance will be installed to reduce or eliminate the tracking or deposition of sediment onto the public right-of-way during construction. The access point shall be maintained in a condition which will prevent tracking of sediment onto public rights-of-way or streets. This may require periodic top dressing with additional aggregate. All sediment spilled, dropped, or washed onto public rights-of-way must be removed immediately.
- Silt Fence (SF) - The silt fence will be installed as shown on the Project Drawings and as necessary during construction to reduce sheet-flow and runoff velocity and reduce the amount of sediment within the sheet-flow/runoff. It will also be utilized to protect the bio-retention area from sediment laden runoff until the adjacent areas are stabilized. Maintenance shall be performed as needed and material removed when 'bulges' develop in the silt fence.
- Fiber Roll (FR) -Fiber rolls may be utilized in place of silt fence for sediment control and as inlet protection if installed according to manufacturer's specifications. Maintenance shall be performed as needed. Maintenance includes replacing slumping rolls, removing accumulated sediment, and filling in rills.

- Dust Control - Dust control will be implemented routinely to reduce dust movement from disturbed soil surfaces to off-site areas where it may cause health hazards, inconvenience and traffic safety problems.
- Temporary Vegetation (TV) - Temporary vegetation will be established on all areas as shown on the Project Drawings and as necessary on all other disturbed areas that remain inactive for more than fourteen (14) days. This will significantly reduce the erosion of the disturbed soils until the area becomes active again.
- Check Dams - The check dams will be utilized within the vegetated swales and as necessary, to reduce erosion in the ditches during grading and/or installation of the proposed pipe culverts by restricting the velocity of flow in the channel until permanent vegetation/stabilization can be established. The check dams should be inspected after each runoff event. Correct all damage immediately. If significant erosion has occurred between structures, a liner of stone or other suitable material should be installed in that portion of the channel or additional check dams added. Remove sediment accumulated behind the dam as needed to allow channel to drain through the stone check dam and prevent large flows from carrying sediment over the dam.

The proposed construction activity is likely to result in more than five (5) acres of disturbance at one time. Once construction activities approach 5 acres of disturbance, the owner will request authorization to disturb greater than 5 acres and will implement stormwater inspections two times per week while greater than 5 acres are disturbed.

B. Permanent Erosion and Sediment Control Measures

The following permanent erosion and sediment control measures, vegetative practices and green infrastructure techniques will be used to provide long-term control of erosion and sedimentation when construction activities are completed and the project site is stabilized:

- Enclosed Storm Drainage System -Enclosed storm drainage systems will be constructed within the site, perimeter perforated pipe within the gravel area around the Electrolyzer Building and bio-retention area, along with their associated conveyance systems and their discharge points.
- Rock Outlet Protection (OP) - The rock protection (rip-rap) will be installed as shown on the Project Drawings at the pipe outlets from the enclosed storm drainage system to the vegetated swales and the Tributary Wetland ditch along the north property line. It will be utilized to reduce the depth, velocity and energy of the water leaving the stormwater conveyance system and minimize the erosion of the receiving downstream channel.

Plug Power Hydrogen Production Facility (STAMP Project Gateway)

May 21, 2021 Stormwater Pollution Prevention Plan & Design Report

- Vegetated Dry Detention Pond - A vegetated dry detention pond will be constructed to filter flow and detain peak discharges from the site during larger storm events.
- Vegetated Swale - Vegetated swales will be established along the northern and western property lines leading to both the bio-retention area and vegetated dry detention pond to increase the time of concentration, reduce the peak discharge, provide infiltration and to serve as pre-treatment by conveying stormwater at a low velocity, promoting natural treatment and infiltration.
- Permanent Vegetation (PV) - Permanent vegetation will be established on all areas as shown on the Project Drawings and as necessary on all other disturbed areas upon the completion of construction. This will significantly reduce the erosion of the disturbed soils while the site stabilizes and during daily use of the site following construction. A landscaped buffer will also be established along the site frontage for screening from Crosby Road.

The location and construction information for implementation of the permanent measures for the project are indicated on the Project Drawings. The details showing materials, sizing and installation requirements can be found in Appendix G and on the Project Drawings.

C. Sequence of Construction and Erosion Control Installation

The following is the anticipated construction sequence to be utilized. The contractor must notify the owner of any significant deviations from this sequence:

1. Install the stabilized construction entrance/exit per Project Drawings and Appendix G.
2. Install the silt fence/fiber roll per Project Drawings and Appendix G.
3. Strip and stockpile any topsoil and sub-soil in designated areas (see Project Drawings). All stockpiled material shall be seeded and silt fence/fiber roll placed around perimeter immediately.
4. Begin earthwork and grading for the site development and drainage, along with the bio-retention area, vegetated dry detention pond and vegetated swales.
5. Additional silt fence/fiber roll, storm drain inlet protection and dust control will be implemented as necessary in conjunction with the earthwork construction activities.

6. Install storm drainage for the site and bio-retention area, as shown on the Project Drawings.
7. Install site utilities and infrastructure.
8. Continue site activities for the construction of the Buildings and supporting facilities.
9. Complete remaining site construction, fine grade and topsoil remaining disturbed areas. Spread permanent seed mix in required areas, including the vegetated dry detention pond and vegetated swales. Vegetation should be established as soon as possible as detailed on the Project Drawings.
10. Complete soil media, mulch and planting installation within the bio-retention area.
11. Remove temporary soil erosion and sediment controls after permanent vegetation has been established and project site is stabilized. A project site is considered stabilized only after a minimum of 80% vegetative density is established on the entire project site.

All soil erosion and sediment control measures must be installed and maintained in conformance with The Plan, the Project Drawings and the *New York State Department of Environmental Conservation SPDES General Permit for Stormwater Discharges from Construction Activity* Permit No. GP-0-20-001.

D. Construction Site Wastes

The following best management practices shall be implemented to ensure proper storage and handling of construction site wastes:

- Designate an onsite water / concrete waste collection area that does not receive a substantial amount of runoff from upland area and does not drain directly to a water body.
- Ensure that any containers have lids so they can be covered before periods of rain. Material / chemical containers should be kept in a covered area whenever possible.
- Ensure waste collection frequency is adequate to prevent receptacles from overflowing.
- Clean up spills immediately. For hazardous materials, follow cleanup instructions on package. For smaller spills, use an absorbent material such as sawdust or kitty litter to contain the spill.

Plug Power Hydrogen Production Facility (STAMP Project Gateway)

May 21, 2021 Stormwater Pollution Prevention Plan & Design Report

- Collect, remove and dispose of all construction site wastes at authorized disposal areas. A local environmental agency can be contacted to identify the disposal sites.

If pesticides are required, the following practices should be used to reduce health and environmental risks associated with pesticides as well as reduce the amount of pesticides that may come in contact with stormwater:

- Follow all federal, state and local regulations that apply to the use, handling or disposal of pesticides.
- Do not handle the materials any more than necessary.
- Store pesticides/fertilizers in a dry, covered area.
- Construct curbs or dikes to contain pesticides in case of spillage.
- Follow the recommended application rates and methods.
- Have equipment and absorbent materials available in areas where pesticides are stored and used in order to contain and clean up any spills that occur.

The following management practices should be followed to reduce the contamination risk associated with petroleum products:

- Store petroleum products and fuel for vehicles in covered areas with dikes in place to contain any spills.
- Immediately contain and clean up any spills with absorbent materials.
- Have equipment available in fuel storage areas and in vehicles to contain and clean up any spills that occur.

To reduce risks of nutrient pollution, the following management practices shall apply:

- Have equipment available in storage areas and in vehicles to contain and clean up any spills that occur.
- Apply fertilizers at the minimum rate and to the minimum area needed.
- Work the fertilizer deeply into the soil to reduce exposure of nutrients to storm water runoff.

- Apply fertilizer at lower application rates with a higher application frequency.
- Limit hydro-seeding, which is the simultaneous application of lime and fertilizers.
- Ensure that erosion and sediment controls are in place to prevent fertilizers and sediments from being transported off-site.
- Use detergents only as recommended and limit their onsite use. Wash water containing detergents should not be mixed with storm water. All polluted waste waters shall be directed to a sanitary sewer or be otherwise contained so that polluted waters may be appropriately treated at a wastewater treatment plant.

IV. INSPECTIONS AND MAINTENANCE

A. General Construction Site Inspection and Maintenance Requirements

1. The *owner or operator* must ensure that all erosion and sediment control practices (including pollution prevention measures) and all post construction stormwater management practices identified in the SWPPP are inspected and maintained in accordance with Part IV.B and C. of the General Permit (GP-0-20-001).
2. The terms of the Permit shall not be construed to prohibit the State of New York from exercising any authority pursuant to the ECL, common law or federal law, or prohibit New York State from taking any measures, whether civil or criminal, to prevent violations of the laws of the State of New York or protect the public health and safety and/or the environment.

B. Contractor Maintenance Inspection Requirements

1. The owner or operator of each construction activity shall have a trained contractor inspect the erosion and sediment control practices and pollution prevention measures being implemented within the active work area daily to ensure that they are being maintained in effective operating condition at all times. If deficiencies are identified, the contractor shall begin implementing corrective actions within one business day and shall complete the corrective actions in a reasonable time frame. The erosion control measures must be maintained/repaired/replaced as necessary such that each measure will meet the specifications included in Appendix G and the latest version of the New York State Standards and Specifications for Erosion and Sediment Control. The specifications include standard maintenance practices for each or the proposed measures.
2. For construction sites where soil disturbance activities have been temporarily suspended (e.g. winter shutdown) and temporary stabilization measures have been applied to all disturbed areas, the *trained contractor* can stop conducting the maintenance inspections. The *trained contractor* shall begin conducting the maintenance inspections in accordance with Part IV.B.1. of the General Permit, as soon as soil disturbance activities resume.
3. For construction sites where soil disturbance activities have been shut down with partial project completion, the *trained contractor* can stop conducting the maintenance inspections if all areas disturbed as of the project shutdown date have achieved *final stabilization* and all post-construction stormwater management practices required for the completed portion of the project have been constructed in conformance with the SWPPP and are operational.

C. Qualified Inspector Inspection Requirements

During construction, the *owner or operator* will provide a qualified inspector to inspect all erosion and sediment control practices to ensure integrity and effectiveness, all areas of disturbance that have not achieved final stabilization, and all points of discharge to natural surface water bodies located within, or immediately adjacent to, the boundaries of the construction site, and all points of discharge from the construction site. Inspection forms can be found in Appendix H.

Site inspections shall be performed according to the following schedule:

- a. For construction sites where soil disturbance activities are ongoing, the *qualified inspector* shall conduct a site inspection at least once every seven (7) calendar days.
- b. For construction sites where soil disturbance activities are ongoing and the *owner or operator* has received authorization in accordance with Part II.C.3 of the General Permit to disturb greater than five (5) acres of soil at any one time, the *qualified inspector* shall conduct at least two (2) site inspections every seven (7) calendar days. The two (2) inspections shall be separated by a minimum of two (2) full calendar days.
- c. For construction sites where soil disturbance activities have been temporarily suspended (e.g. winter shutdown) and temporary stabilization measures have been applied to all disturbed areas, the *qualified inspector* shall conduct a site inspection at least once every thirty (30) calendar days. The *owner or operator* shall notify the Regional Office stormwater contact person or, in areas under the jurisdiction of a *regulated, traditional land use control MS4*, the MS4 in writing prior to reducing the frequency of inspections.
- d. For construction sites where soil disturbance activities have been shut down with partial project completion, the *qualified inspector* can stop conducting inspections if all areas disturbed as of the project shutdown date have achieved *final stabilization* and all post-construction stormwater management practices required for the completed portion of the project have been constructed in conformance with the SWPPP and are operational. The *owner or operator* shall notify the Regional Office stormwater contact person or, in areas under the jurisdiction of a *regulated, traditional land use control MS4*, the MS4 in writing prior to the shutdown. If soil disturbance activities are not resumed within 2 years from the date of shutdown, the *owner or operator* shall have the *qualified inspector(s)* perform a final inspection and certify that all disturbed areas have achieved *final stabilization*, and all temporary, structural erosion and sediment control measures have been removed; and that all post-construction

stormwater management practices have been constructed in conformance with the SWPPP by signing the "Final Stabilization" and "Post-Construction Stormwater Management Practice" certification statements on the Notice of Termination (NOT). The *owner or operator* shall then submit the completed NOT form to the address in Part II.A.1 of Permit No. GP-0-20-001.

- e. For construction sites that directly discharge to one of the 303(d) segments listed in Appendix E of the General Permit or is located in one of the watersheds listed in Appendix C of the General Permit, the qualified inspector shall conduct at least two (2) site inspections every seven (7) calendar days. The two (2) inspections shall be separated by a minimum of two (2) full calendar days.

At a minimum, the qualified inspector shall inspect all erosion and sediment control practices and pollution prevention measures to ensure integrity and effectiveness, all post-construction stormwater management practices under construction to ensure that they are constructed in conformance with the SWPPP, all areas of disturbance that have not achieved final stabilization, all points of discharge to natural surface waterbodies located within, or immediately adjacent to, the property boundaries of the construction site, and all points of discharge from the construction site.

The *qualified inspector* shall prepare an inspection report subsequent to each and every inspection. At a minimum, the inspection reports shall include and/or address the following:

- a. Date and time of inspection;
- b. Name and title of person(s) performing inspection;
- c. A description of the weather and soil conditions (e.g. dry, wet, saturated) at the time of the inspection;
- d. A description of the condition of the runoff at all points of discharge from the construction site. This shall include identification of any discharges of sediment from the construction site. Include discharges from conveyance systems (i.e. pipes, culverts, ditches, etc.) and overland flow;
- e. A description of the condition of all natural surface water bodies located within, or immediately adjacent to, the property boundaries of the construction site which receive runoff from disturbed areas. This shall include identification of any discharges of sediment to the surface water body.
- f. Identification of all erosion and sediment control practices that need repair or maintenance;

Plug Power Hydrogen Production Facility (STAMP Project Gateway)

May 21, 2021 Stormwater Pollution Prevention Plan & Design Report

- g. Identification of all erosion and sediment control practices that were not installed properly or are not functioning as designed and need to be reinstalled or replaced;
- h. Description and sketch of areas that are disturbed at the time of the inspection and areas that have been stabilized (temporary and/or final) since the last inspection;
- i. Current phase of construction of all post-construction stormwater management practices and identification of all construction that is not in conformance with the SWPPP and technical standards; and
- j. Corrective action(s) that must be taken to install, repair, replace or maintain erosion and sediment control practices; and to correct deficiencies identified with the construction of the post-construction stormwater management practice(s).
- k. Identification and status of all corrective actions that were required by previous inspection
- l. Digital photographs, with date stamp, that clearly show the condition of all practices that have been identified as needing corrective actions. The qualified inspector shall attach paper color copies of the digital photographs to the inspection report being maintained onsite within seven (7) calendar days of the date of the inspection. The qualified inspector shall also take digital photographs, with date stamp, that clearly show the condition of the practice(s) after the corrective action has been completed. The qualified inspector shall attach paper color copies of the digital photographs to the inspection report that documents the completion of the corrective action work within seven (7) calendar days of that inspection.
- m. All inspection reports shall be signed by the qualified inspector.

Within one business day of the completion of an inspection, the *qualified inspector* shall notify the *owner or operator* and appropriate contractor (or subcontractor) of any corrective actions that need to be taken. The contractor (or subcontractor) shall begin implementing the corrective actions within one business day of this notification and shall complete the corrective actions in a reasonable time frame. The erosion control measures must be maintained/repared/replaced as necessary such that each measure will meet the specifications included in Appendix G. The specifications include standard maintenance practices for each or the proposed measures. The Plan shall be revised and the measures updated in accordance with sound engineering practices, the guidelines of the General Permit and the Project Drawings. The Project Engineer is to be notified of any significant revisions to the implemented measures or The Plan.

V. POST-CONSTRUCTION OPERATION AND MAINTENANCE

Post-construction, Plug Power will provide a qualified inspector to inspect and maintain the stormwater conveyance system, the bio-retention area, the vegetated dry detention pond and the outlet structures at least twice annually and after a 25-year or greater storm event. During each inspection, the qualified inspector shall inspect the permanent stormwater management practices and stormwater conveyance system to ensure they are clear of silt, debris, weeds and woody plants. Removal of material shall be by mechanical methods or by hand. All material removed shall be disposed of by an approved method. All areas of permanent vegetation shall be fertilized, as necessary, to keep the vegetation healthy and vigorous and at a minimum density of eighty (80) percent over the entire pervious surface. Vegetation within the vegetated dry detention pond and vegetated swales should be maintained at an approximate 6" height. The Bioretention Operation, Maintenance and Management Inspection Checklist from Appendix G of the NYSEC Stormwater Management Design Manual can be found in Appendix H for use by the qualified inspector.

Appendix H.2 Bioretention from the NYSDEC Stormwater Management Design Manual is also included in Appendix J of the SWPPP document to address the specifications for the mulch and plantings for the bio-retention areas. Silt/sediment shall be removed from the filter bed of the bio-retention areas when the accumulation exceeds one inch. When the filtering capacity of the filter diminishes substantially such that water ponds on the surface for more than 48 hours, the top few inches of discolored material shall be removed and shall be replaced with fresh material.

The following two-year maintenance schedule shall be followed for the bio-retention areas:

<u>Description</u>	<u>Method</u>	<u>Frequency</u>	<u>Time of Year</u>
Watering	Hand Hose or Sprinkler	At planting, once/week for 1 st month if < 1" rain received. As necessary thereafter to maintain health of plants (min. ½"/week)	November May-August
Inspection	Visual	Once per week for first month, monthly thereafter	Growing Season
Replacement	Root Stock or Seed, as necessary	As needed during first two years of growing season per visual inspection	Growing Season

VI. ADDITIONAL INFORMATION

1. Contractor and subcontractors must review the New York State Department of Environmental Conservation SPDES General Permit for Stormwater Discharges from Construction Activity permit No. GP-0-20-001, effective January 29, 2015. Any questions or concerns regarding material discussed in this General Permit should be immediately directed to the permittee.

Each contractor and subcontractor that will perform on the site actions which may reasonably be expected to cause or have the potential to cause pollution of the waters of the State of New York, shall sign the contractor's certification statement at the back of this Stormwater Pollution Prevention Plan (SWPPP) in Appendix E.

2. The *owner or operator* shall maintain a copy of the General Permit (GP-0-20-001), NOI, *NOI Acknowledgment Letter*, SWPPP, MS4 SWPPP Acceptance form, inspection reports, and all documentation necessary to demonstrate eligibility with this permit at the construction site until all disturbed areas have achieved *final stabilization* and the NOT has been submitted to the Department. The documents must be maintained in a secure location, such as a job trailer, on-site construction office, or mailbox with lock. The secure location must be accessible during normal business hours to an individual performing a compliance inspection.
3. The owner or operator shall ensure that the provisions of the SWPPP are implemented from the commencement of construction activity until all areas of disturbance have achieved final stabilization and the Notice of Termination ("NOT") has been submitted to the Department in accordance with Part V. of this permit. This includes any changes made to the SWPPP pursuant to Part III.A.4. of the General Permit.
4. The *owner or operator* shall retain a copy of the NOI, NOI Acknowledgment Letter, SWPPP, MS4 SWPPP Acceptance form and any inspection reports that were prepared in conjunction with this permit for a period of at least five (5) years from the date that the site achieves final stabilization. This period may be extended by the Department of Environmental Conservation, in its sole discretion, at any time upon written notification.
5. The owner operator of a construction activity shall not disturb greater than five (5) acres of soil at any one time without prior written authorization from the Department or, in areas under the jurisdiction of a regulated, traditional land use control MS4, the MS4. At a minimum, the owner or operator must comply with the following requirements in order to be authorized to disturb greater than five (5) acres of soil at one time:

- a) The *owner or operator* shall have a qualified inspector conduct at least two (2) site inspections every seven (7) calendar days, for as long as greater than five (5) acres of soil remain disturbed. The two (2) inspections shall be separated by a minimum of two (2) full calendar days.
 - b) In areas where soil disturbance activity has been temporarily or permanently ceased, temporary and/or permanent soil stabilization measures shall be installed and/or implemented within seven (7) days from the date the soil disturbance activity ceased. The soil stabilization measures selected shall be in conformance with the most current version of technical standard, New York State Standards and Specifications for Erosion and Sediment Control.
 - c) The *owner of operator* shall prepare a phasing plan that defines maximum disturbed area per phase and shows required cuts and fills.
 - d) The *owner or operator* shall install any additional site-specific practices needed to protect water quality.
 - e) The *owner or operator* shall include the requirements above in their SWPPP.
6. The following list describes some of the construction materials that may be stored at the project site:
- Drainage and construction materials (plastic pipe, catch basins, end-sections)
 - Stone
 - Fill and Topsoil
 - Soil Erosion and Sediment Control Materials for immediate repairs
 - Construction Equipment
7. A Notice of Termination (N.O.T.) must be filed with the NYS DEC upon completion of the project. The Notice of Termination form can be found in Appendix D of this plan.

An *owner or operator* may terminate coverage when one or more the following conditions have been met:

- a. Total project completion - All construction activity identified in the SWPPP has been completed; and all areas of disturbance have achieved final stabilization; and all temporary, structural erosion and sediment control measures have been removed; and all post-construction stormwater management practices have been constructed in conformance with the SWPPP and are operational;

Plug Power Hydrogen Production Facility (STAMP Project Gateway)

May 21, 2021 Stormwater Pollution Prevention Plan & Design Report

- b. Planned shutdown with partial project completion - All soil disturbance activities have ceased; and all areas disturbed as of the project shutdown date have achieved final stabilization; and all temporary, structural erosion and sediment control measures have been removed; and all postconstruction stormwater management practices required for the completed portion of the project have been constructed in conformance with the SWPPP and are operational;
- c. A new *owner or operator* has obtained coverage under The Permit in accordance with Part II.F of the General Permit.
- d. The owner or operator obtains coverage under an alternative SPDES general permit or an individual SPDES permit.

For *construction activities* meeting a. or b. above, the *owner or operator* shall have the *qualified inspector* perform a final site inspection prior to submitting the NOT. The qualified inspector shall, by signing the "Final Stabilization" and "Post-Construction Stormwater Management Practice" certification statements on the NOT, certify that all the requirements in Part V.A.2.a. or b. of the General Permit have been achieved.

For construction activities that are subject to the requirements of a regulated, traditional land use control MS4 and meeting a. or b. above, the owner or operator shall have the regulated, traditional land use control MS4 sign the "MS4 Acceptance" statement on the NOT in accordance with the requirements in Part VII.H. of the General Permit. The regulated, traditional land use control MS4 official, by signing this statement, has determined that it is acceptable for the owner or operator to submit the NOT in accordance with the requirements of this Part. The regulated, traditional land use control MS4 can make this determination by performing a final site inspection themselves or by accepting the qualified inspector's final site inspection certification(s) as required above.

For post-construction stormwater management practices that are privately owned, the owner or operator shall have a mechanism in place that requires operation and maintenance of the practice(s) in accordance with the operation and maintenance plan, such as a deed covenant in the owner or operator's deed of record.

- 8. Permittee, Contractor and Sub-contractor to implement best management practices (BMP) to prevent litter, debris, building materials, or similar material from being discharged into waters of the State of New York.
- 9. The Plan shall be revised, and the measures updated, as site conditions require, in accordance with sound engineering practices, the guidelines of the General Permit and the Project Drawings. The Project Engineer is to be notified of any significant revisions to the implemented measures or The Plan.

Plug Power Hydrogen Production Facility (STAMP Project Gateway)

May 21, 2021 Stormwater Pollution Prevention Plan & Design Report

10. Upon the completion of construction, the bio-retention area, vegetated dry detention pond, the vegetated swales and the site's enclosed storm drainage system will become the responsibility of Plug Power.
11. The Town of Alabama shall approve a formal maintenance agreement for stormwater management facilities binding on all subsequent landowners and recorded in the office of the County Clerk as a deed restriction on the property prior to final plan approval. The maintenance agreement shall be consistent with the terms and conditions of the Sample Stormwater Control Facility Maintenance Agreement in Appendix K of this document.

VII. OWNER/OPERATOR CERTIFICATION STATEMENT

The following certification shall be made in accordance with the SPDES General Permit for Stormwater Discharges from Construction Activity, Permit GP-0-20-001

"I certify under penalty of law that this document and all attachments were prepared under my direction or supervision in accordance with a system designed to assure that qualified personnel properly gathered and evaluated the information submitted. Based on my inquiry of the person or persons who manage the system, or those persons directly responsible for gathering the information, the information submitted is to the best of my knowledge and belief, true, accurate and complete. I am aware that false statements made herein are punishable as a class A misdemeanor pursuant to Section 210.45 of the Penal Law."

Signature: _____ Date: _____

Print Name: Brenor Brophy

Title: Vice-President, Project Development

Company: Plug Power

Address: 968 Albany Shaker Road
Latham, NY 12110

Phone: (408) 823-6566

Email Address: brbrophy@plugpower.com

Appendix A

Drainage Calculations

Appendix A-1

Drainage Calculations

Existing Conditions

Soil Map—Genesee County, New York
(Gateway Site)



Soil Map may not be valid at this scale.

Map Scale: 1:2,760 if printed on A landscape (11" x 8.5") sheet.

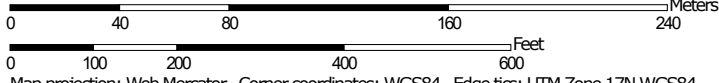

Map projection: Web Mercator Corner coordinates: WGS84 Edge tics: UTM Zone 17N WGS84

MAP LEGEND

Area of Interest (AOI)

 Area of Interest (AOI)

Soils

 Soil Map Unit Polygons

 Soil Map Unit Lines

 Soil Map Unit Points

Special Point Features



Blowout



Borrow Pit



Clay Spot



Closed Depression



Gravel Pit



Gravelly Spot



Landfill



Lava Flow



Marsh or swamp



Mine or Quarry



Miscellaneous Water



Perennial Water



Rock Outcrop



Saline Spot



Sandy Spot



Severely Eroded Spot



Sinkhole



Slide or Slip



Sodic Spot



Spoil Area



Stony Spot



Very Stony Spot



Wet Spot



Other



Special Line Features

Water Features



Streams and Canals

Transportation



Rails



Interstate Highways



US Routes



Major Roads



Local Roads

Background



Aerial Photography

MAP INFORMATION

The soil surveys that comprise your AOI were mapped at 1:24,000.

Warning: Soil Map may not be valid at this scale.

Enlargement of maps beyond the scale of mapping can cause misunderstanding of the detail of mapping and accuracy of soil line placement. The maps do not show the small areas of contrasting soils that could have been shown at a more detailed scale.

Please rely on the bar scale on each map sheet for map measurements.

Source of Map: Natural Resources Conservation Service
Web Soil Survey URL:
Coordinate System: Web Mercator (EPSG:3857)

Maps from the Web Soil Survey are based on the Web Mercator projection, which preserves direction and shape but distorts distance and area. A projection that preserves area, such as the Albers equal-area conic projection, should be used if more accurate calculations of distance or area are required.

This product is generated from the USDA-NRCS certified data as of the version date(s) listed below.

Soil Survey Area: Genesee County, New York
Survey Area Data: Version 21, Jun 11, 2020

Soil map units are labeled (as space allows) for map scales 1:50,000 or larger.

Date(s) aerial images were photographed: Dec 31, 2009—Oct 18, 2016

The orthophoto or other base map on which the soil lines were compiled and digitized probably differs from the background imagery displayed on these maps. As a result, some minor shifting of map unit boundaries may be evident.

Map Unit Legend

Map Unit Symbol	Map Unit Name	Acres in AOI	Percent of AOI
CaA	Canandaigua silt loam, 0 to 2 percent slopes	1.9	6.7%
CIB	Collamer silt loam, 2 to 6 percent slopes	0.8	2.9%
La	Lakemont silty clay loam, 0 to 3 percent slopes	7.0	24.2%
NgA	Niagara silt loam, 0 to 2 percent slopes	0.4	1.4%
OdB	Odessa silt loam, 3 to 8 percent slopes	18.6	64.7%
Totals for Area of Interest		28.8	100.0%

MAP REFERENCES:
 PROPOSED WYDER PARCEL A, A PORTION OF SBL 10-142, BOUNDARY SURVEY PART OF LOT 14, TWP 13, RGE 4 OF THE TONAWANDA RESERVATION, TOWN OF ALABAMA, COUNTY OF GENESSEE AND STATE OF NEW YORK, PREPARED BY FRANDINA ENGINEERING AND LAND SURVEYING, P.C, DATED FEBRUARY 16, 2021, JOB No. 3646-3B.
 TOPOGRAPHIC SURVEY PART OF LOT 14, TWP 13, RGE 4 OF THE TONAWANDA RESERVATION, TOWN OF ALABAMA, COUNTY OF GENESSEE AND STATE OF NEW YORK, PREPARED BY FRANDINA ENGINEERING AND LAND SURVEYING, P.C, DATED FEBRUARY 26, 2021, JOB No. 3646-3B.

LEGEND

—ST—	STORM SEWER LINE
INV	INVERT ELEVATION
UP	UTILITY POLE
UPL	UTILITY POLE W/ LIGHT
—OHW—	OVERHEAD WIRES
MW	MONITORING WELL
EP	EDGE OF PAVEMENT
CP	PRIMARY CONTROL POINT
(Circle with cross)	TREE DECIDUOUS
(Star)	TREE CONIFEROUS

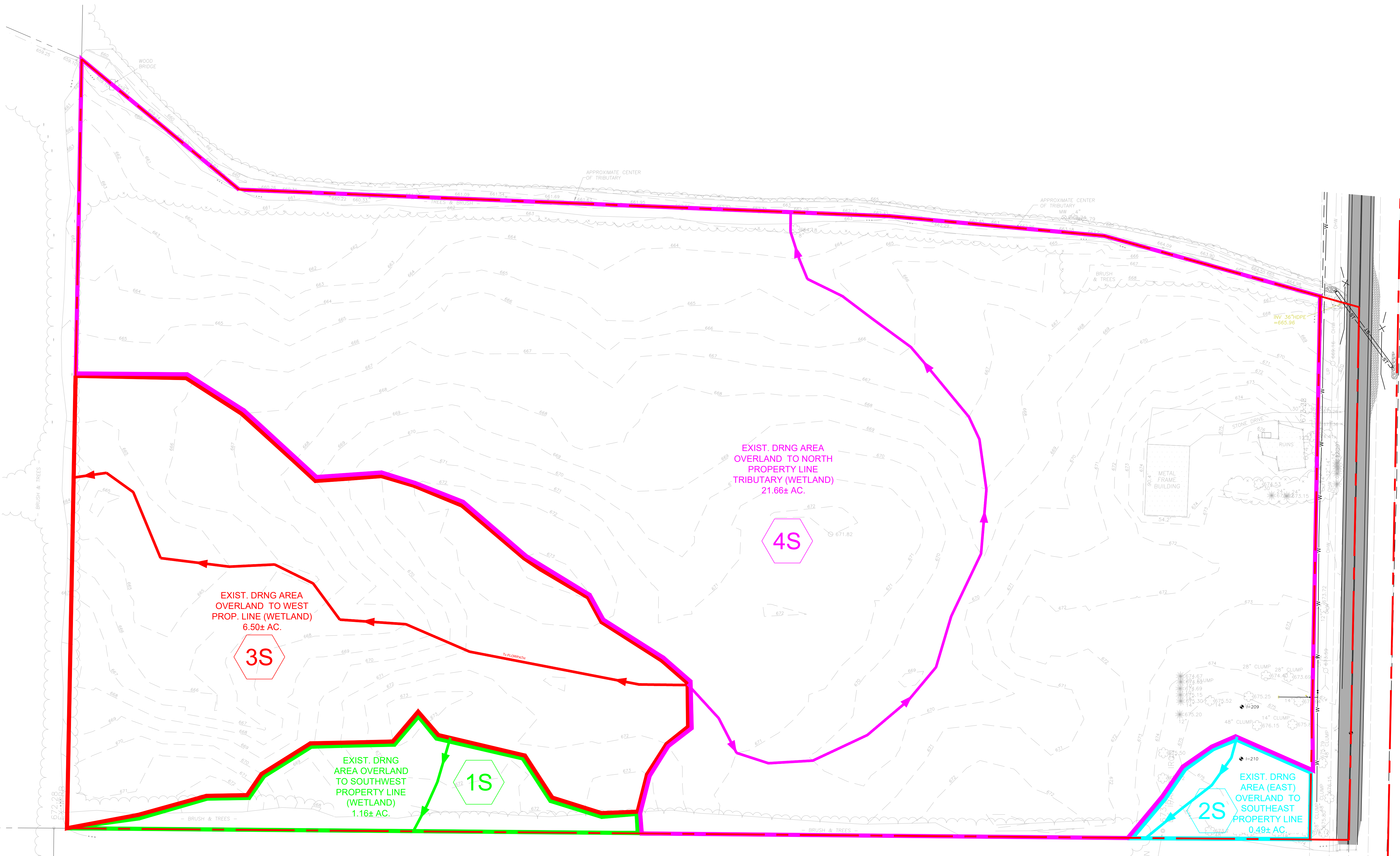
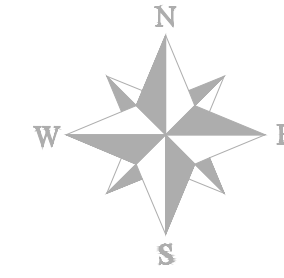

EXISTING CONDITIONS DRAINAGE MAP
 SCALE: 1"=60'



NO.	ISSUE DATE	REVISION DESCRIPTION
0	05-15-2021	SITE PLAN SUBMITTAL
1		
2		
3		
4		
5		
6		
7		
8		

CLIENT:
 PLUG POWER
 968 ALBANY SHAKER ROAD
 LATHAM, NY 12110

PROJECT:
 PLUG POWER HYDROGEN
 PRODUCTION FACILITY



4759 N 5th Street
 Lewiston, NY 14092
 Phone: (716) 946-2415
 Email: rhaight@invictuscivilengineering.com

SEAL/SIGNATURE

Following is an excerpt from the New York State Education Law, Article 145, Section 7209 & applies to this drawing. It is a violation of this law for any person unless he is acting under the direct supervision of a licensed professional engineer to alter an item in any way, if an item bearing the seal of a professional engineer is altered, the altering engineer shall affix his seal and the notation "ALTERED BY" followed by his signature and date of such alteration and a specific description of the alteration. This drawing is copyrighted under the United States Copy Right Law and is the property of Invictus Civil Engineering, P.C. The use of this drawing in any form without written permission is strictly prohibited.

SHEET TITLE:
EXISTING CONDITIONS DRAINAGE MAP

SHEET:
DR-000

SCALE AS NOTED PROJECT # 21-1002 DATE 05/15/2021

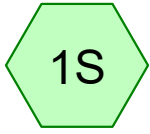

Area to SW Property Line (Wetland)



Area to SE Property Line

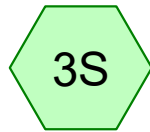

Area to West Property Line (Wetland)

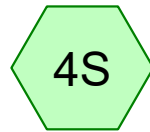

Area to North Property Line Ditch (Wetland)

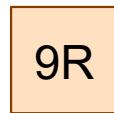

North Property Line Ditch



Total Site Discharge

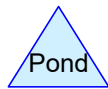
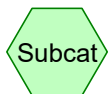

Routing Diagram for Plug Power - Existing Conditions 5-15-21
Prepared by {enter your company name here}, Printed 5/21/2021
HydroCAD® 10.10-5a s/n 11585 © 2020 HydroCAD Software Solutions LLC

Plug Power - Existing Conditions 5-15-21

Prepared by {enter your company name here}

HydroCAD® 10.10-5a s/n 11585 © 2020 HydroCAD Software Solutions LLC

Printed 5/21/2021

Page 2

Project Notes

Defined 9 rainfall events from Gateway IDF

Plug Power - Existing Conditions 5-15-21

Prepared by {enter your company name here}

HydroCAD® 10.10-5a s/n 11585 © 2020 HydroCAD Software Solutions LLC

Printed 5/21/2021

Page 3

Rainfall Events Listing (selected events)

Event#	Event Name	Storm Type	Curve	Mode	Duration (hours)	B/B	Depth (inches)	AMC
1	1-yr	Type II 24-hr		Default	24.00	1	1.82	2
2	10-yr	Type II 24-hr		Default	24.00	1	3.04	2
3	25-yr	Type II 24-hr		Default	24.00	1	3.71	2
4	100-yr	Type II 24-hr		Default	24.00	1	5.01	2

Plug Power - Existing Conditions 5-15-21

Prepared by {enter your company name here}

HydroCAD® 10.10-5a s/n 11585 © 2020 HydroCAD Software Solutions LLC

Printed 5/21/2021

Page 4

Area Listing (all nodes)

Area (acres)	CN	Description (subcatchment-numbers)
1.433	77	Brush, Fair, HSG D (4S)
0.121	91	Gravel drive, HSG D (4S)
23.955	85	Row crops, SR + CR, Good, HSG D (1S, 3S, 4S)
0.112	98	Unconnected roofs, HSG D (4S)
0.423	79	Woods, Fair, HSG D (1S)
3.052	79	Woods/grass comb., Good, HSG D (2S, 4S)
29.096	84	TOTAL AREA

Plug Power - Existing Conditions 5-15-21

Prepared by {enter your company name here}

HydroCAD® 10.10-5a s/n 11585 © 2020 HydroCAD Software Solutions LLC

Printed 5/21/2021

Page 5

Soil Listing (all nodes)

Area (acres)	Soil Group	Subcatchment Numbers
0.000	HSG A	
0.000	HSG B	
0.000	HSG C	
29.096	HSG D	1S, 2S, 3S, 4S
0.000	Other	
29.096		TOTAL AREA

Plug Power - Existing Conditions 5-15-21

Prepared by {enter your company name here}

HydroCAD® 10.10-5a s/n 11585 © 2020 HydroCAD Software Solutions LLC

Printed 5/21/2021

Page 6

Ground Covers (all nodes)

HSG-A (acres)	HSG-B (acres)	HSG-C (acres)	HSG-D (acres)	Other (acres)	Total (acres)	Ground Cover	Subcatchment Numbers
0.000	0.000	0.000	1.433	0.000	1.433	Brush, Fair	4S
0.000	0.000	0.000	0.121	0.000	0.121	Gravel drive	4S
0.000	0.000	0.000	23.955	0.000	23.955	Row crops, SR + CR, Good	1S, 3S, 4S
0.000	0.000	0.000	0.112	0.000	0.112	Unconnected roofs	4S
0.000	0.000	0.000	0.423	0.000	0.423	Woods, Fair	1S
0.000	0.000	0.000	3.052	0.000	3.052	Woods/grass comb., Good	2S, 4S
0.000	0.000	0.000	29.096	0.000	29.096	TOTAL AREA	

Plug Power - Existing Conditions 5-15-21

Type II 24-hr 1-yr Rainfall=1.82"

Prepared by {enter your company name here}

Printed 5/21/2021

HydroCAD® 10.10-5a s/n 11585 © 2020 HydroCAD Software Solutions LLC

Page 7

Time span=0.00-48.00 hrs, dt=0.14 hrs, 344 points x 2
Runoff by SCS TR-20 method, UH=SCS, Weighted-CN
Reach routing by Dyn-Stor-Ind method - Pond routing by Dyn-Stor-Ind method

Subcatchment 1S: Area to SW Property Runoff Area=50,330 sf 0.00% Impervious Runoff Depth=0.58"
Flow Length=130' Slope=0.0200 '/' Tc=13.9 min CN=83 Runoff=0.79 cfs 0.055 af

Subcatchment 2S: Area to SE Property Line Runoff Area=21,205 sf 0.00% Impervious Runoff Depth=0.42"
Flow Length=180' Slope=0.0150 '/' Tc=20.3 min CN=79 Runoff=0.19 cfs 0.017 af

Subcatchment 3S: Area to West Property Runoff Area=283,655 sf 0.00% Impervious Runoff Depth=0.67"
Flow Length=875' Tc=33.5 min CN=85 Runoff=3.27 cfs 0.361 af

Subcatchment 4S: Area to North Property Runoff Area=912,250 sf 0.54% Impervious Runoff Depth=0.62"
Flow Length=1,100' Tc=39.9 min CN=84 Runoff=8.50 cfs 1.081 af

Reach 9R: North Property Line Ditch Avg. Flow Depth=0.58' Max Vel=1.76 fps Inflow=8.50 cfs 1.081 af
n=0.030 L=1,670.0' S=0.0060 '/' Capacity=470.66 cfs Outflow=6.98 cfs 1.081 af

Link 10L: Total Site Discharge Inflow=9.40 cfs 1.515 af
Primary=9.40 cfs 1.515 af

Total Runoff Area = 29.096 ac Runoff Volume = 1.515 af Average Runoff Depth = 0.62"
99.61% Pervious = 28.984 ac 0.39% Impervious = 0.112 ac

Plug Power - Existing Conditions 5-15-21

Prepared by {enter your company name here}

HydroCAD® 10.10-5a s/n 11585 © 2020 HydroCAD Software Solutions LLC

Type II 24-hr 1-yr Rainfall=1.82"

Printed 5/21/2021

Page 8

Summary for Subcatchment 1S: Area to SW Property Line (Wetland)

Runoff = 0.79 cfs @ 12.07 hrs, Volume= 0.055 af, Depth= 0.58"

Runoff by SCS TR-20 method, UH=SCS, Weighted-CN, Time Span= 0.00-48.02 hrs, dt= 0.14 hrs
Type II 24-hr 1-yr Rainfall=1.82"

Area (sf)	CN	Description
31,900	85	Row crops, SR + CR, Good, HSG D
18,430	79	Woods, Fair, HSG D
50,330	83	Weighted Average
50,330		100.00% Pervious Area

Tc (min)	Length (feet)	Slope (ft/ft)	Velocity (ft/sec)	Capacity (cfs)	Description
13.2	100	0.0200	0.13		Sheet Flow, 100' Overland Flow
					Cultivated: Residue>20% n= 0.170 P2= 2.14"
0.7	30	0.0200	0.71		Shallow Concentrated Flow, 30' Shallow Conc. Flow
					Woodland Kv= 5.0 fps
13.9	130	Total			

Subcatchment 1S: Area to SW Property Line (Wetland)

Hydrograph

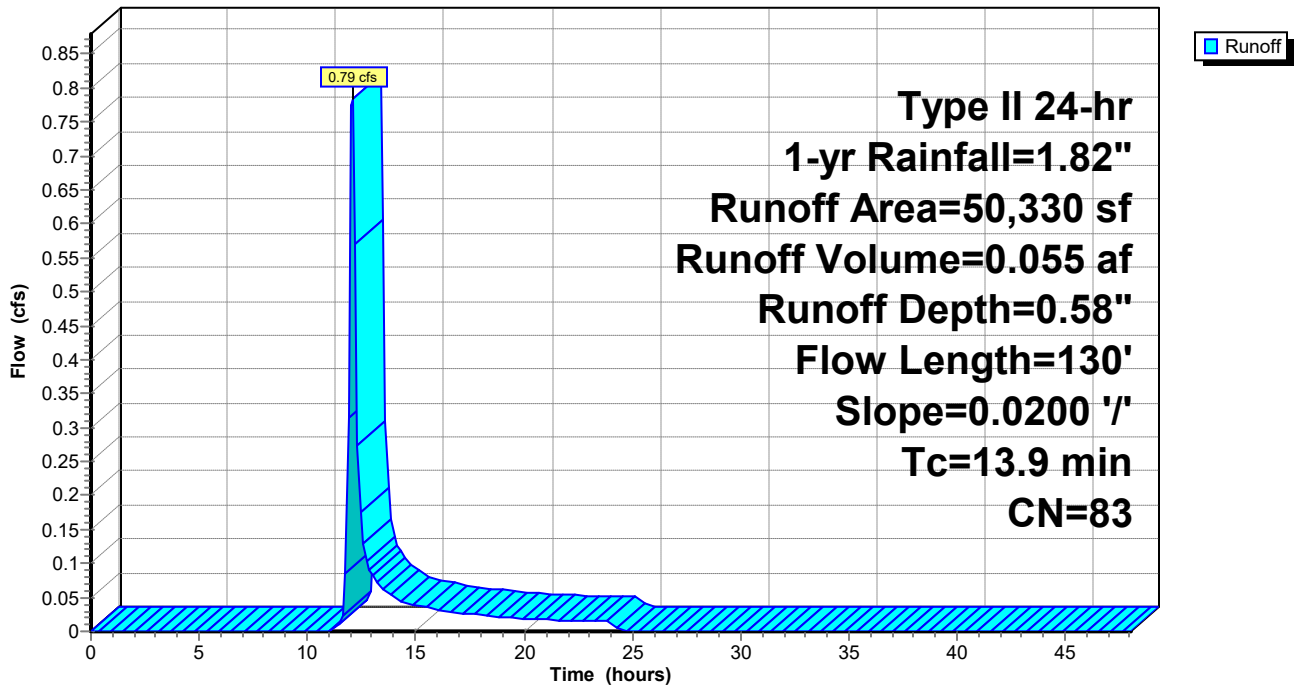

Plug Power - Existing Conditions 5-15-21

Prepared by {enter your company name here}

HydroCAD® 10.10-5a s/n 11585 © 2020 HydroCAD Software Solutions LLC

Type II 24-hr 1-yr Rainfall=1.82"

Printed 5/21/2021

Page 9

Summary for Subcatchment 2S: Area to SE Property Line

Runoff = 0.19 cfs @ 12.18 hrs, Volume= 0.017 af, Depth= 0.42"

Runoff by SCS TR-20 method, UH=SCS, Weighted-CN, Time Span= 0.00-48.02 hrs, dt= 0.14 hrs
Type II 24-hr 1-yr Rainfall=1.82"

Area (sf)	CN	Description
21,205	79	Woods/grass comb., Good, HSG D
21,205		100.00% Pervious Area

Tc (min)	Length (feet)	Slope (ft/ft)	Velocity (ft/sec)	Capacity (cfs)	Description
19.6	100	0.0150	0.09		Sheet Flow, 100' Overland Flow Grass: Dense n= 0.240 P2= 2.14"
0.7	80	0.0150	1.84		Shallow Concentrated Flow, 80' Shallow Conc. Flow Grassed Waterway Kv= 15.0 fps
20.3	180	Total			

Subcatchment 2S: Area to SE Property Line

Hydrograph

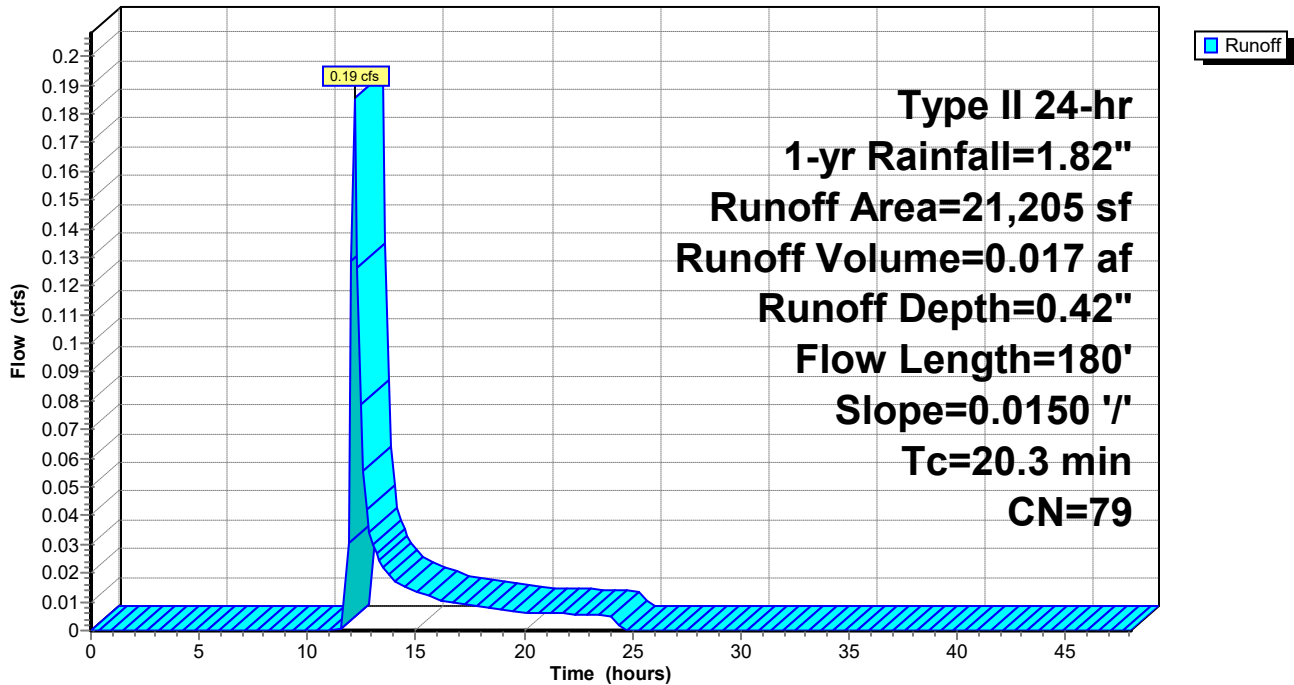

Plug Power - Existing Conditions 5-15-21

Prepared by {enter your company name here}

HydroCAD® 10.10-5a s/n 11585 © 2020 HydroCAD Software Solutions LLC

Type II 24-hr 1-yr Rainfall=1.82"

Printed 5/21/2021

Page 10

Summary for Subcatchment 3S: Area to West Property Line (Wetland)

Runoff = 3.27 cfs @ 12.32 hrs, Volume= 0.361 af, Depth= 0.67"

Runoff by SCS TR-20 method, UH=SCS, Weighted-CN, Time Span= 0.00-48.02 hrs, dt= 0.14 hrs
Type II 24-hr 1-yr Rainfall=1.82"

Area (sf)	CN	Description
283,655	85	Row crops, SR + CR, Good, HSG D
283,655		100.00% Pervious Area

Tc (min)	Length (feet)	Slope (ft/ft)	Velocity (ft/sec)	Capacity (cfs)	Description
19.1	100	0.0080	0.09		Sheet Flow, 100' Overland Flow Cultivated: Residue>20% n= 0.170 P2= 2.14"
14.4	775	0.0100	0.90		Shallow Concentrated Flow, 775' Shallow Conc. Flow Cultivated Straight Rows Kv= 9.0 fps
33.5	875	Total			

Subcatchment 3S: Area to West Property Line (Wetland)

Hydrograph

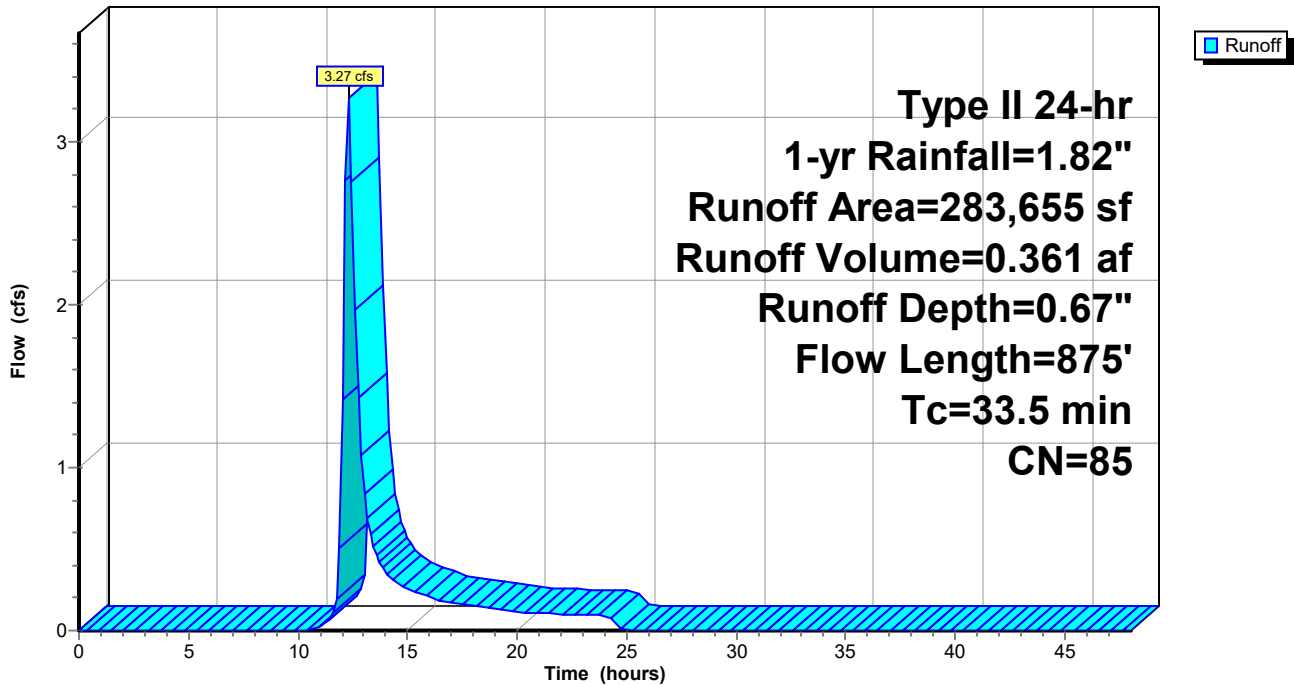

Plug Power - Existing Conditions 5-15-21

Type II 24-hr 1-yr Rainfall=1.82"

Prepared by {enter your company name here}

Printed 5/21/2021

HydroCAD® 10.10-5a s/n 11585 © 2020 HydroCAD Software Solutions LLC

Page 11

Summary for Subcatchment 4S: Area to North Property Line Ditch (Wetland)

Runoff = 8.50 cfs @ 12.40 hrs, Volume= 1.081 af, Depth= 0.62"

Runoff by SCS TR-20 method, UH=SCS, Weighted-CN, Time Span= 0.00-48.02 hrs, dt= 0.14 hrs
Type II 24-hr 1-yr Rainfall=1.82"

Area (sf)	CN	Description
* 5,250	91	Gravel drive, HSG D
111,735	79	Woods/grass comb., Good, HSG D
4,900	98	Unconnected roofs, HSG D
62,430	77	Brush, Fair, HSG D
727,935	85	Row crops, SR + CR, Good, HSG D
912,250	84	Weighted Average
907,350		99.46% Pervious Area
4,900		0.54% Impervious Area
4,900		100.00% Unconnected

Tc (min)	Length (feet)	Slope (ft/ft)	Velocity (ft/sec)	Capacity (cfs)	Description
19.1	100	0.0080	0.09		Sheet Flow, 100' Overland Flow Cultivated: Residue>20% n= 0.170 P2= 2.14"
20.2	975	0.0080	0.80		Shallow Concentrated Flow, 975' Shallow Conc. Flow Cultivated Straight Rows Kv= 9.0 fps
0.6	25	0.0200	0.71		Shallow Concentrated Flow, 25' Shallow Conc. Flow Woodland Kv= 5.0 fps
39.9	1,100	Total			

Subcatchment 4S: Area to North Property Line Ditch (Wetland)

Hydrograph

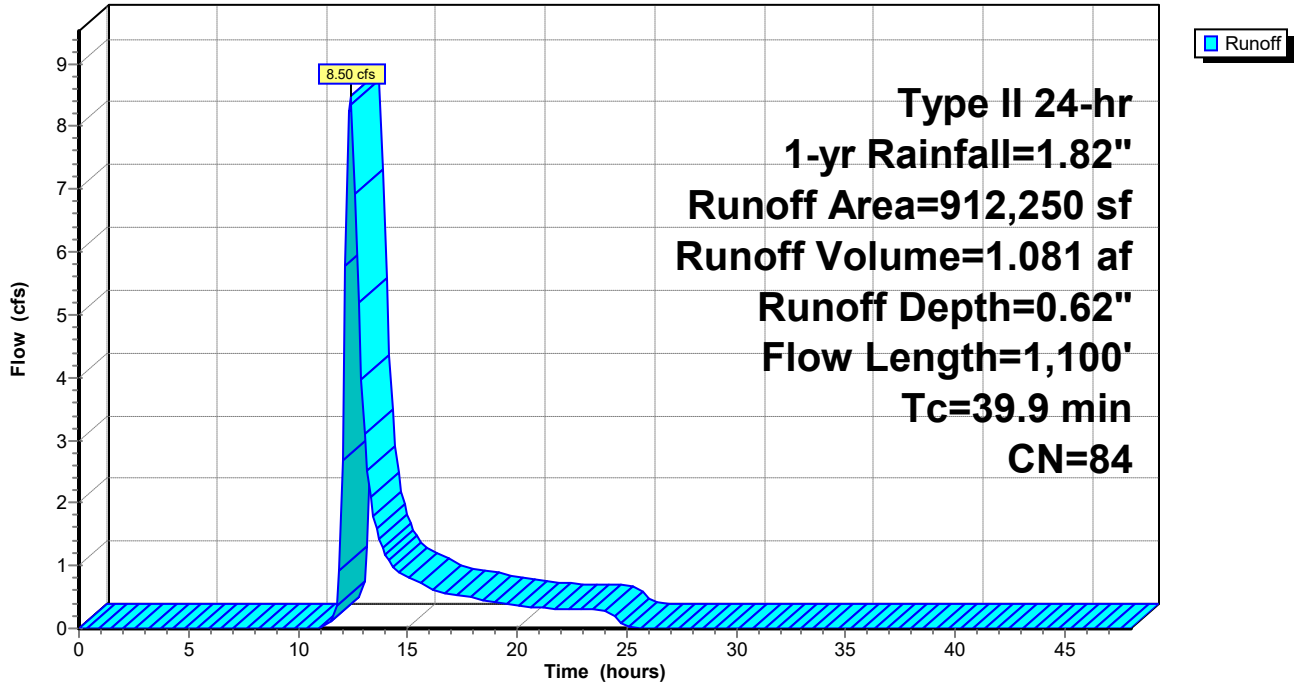

Plug Power - Existing Conditions 5-15-21

Prepared by {enter your company name here}

HydroCAD® 10.10-5a s/n 11585 © 2020 HydroCAD Software Solutions LLC

Type II 24-hr 1-yr Rainfall=1.82"

Printed 5/21/2021

Page 13

Summary for Reach 9R: North Property Line Ditch

Inflow Area = 20.942 ac, 0.54% Impervious, Inflow Depth = 0.62" for 1-yr event
Inflow = 8.50 cfs @ 12.40 hrs, Volume= 1.081 af
Outflow = 6.98 cfs @ 12.61 hrs, Volume= 1.081 af, Atten= 18%, Lag= 12.8 min

Routing by Dyn-Stor-Ind method, Time Span= 0.00-48.02 hrs, dt= 0.14 hrs / 2
Max. Velocity= 1.76 fps, Min. Travel Time= 15.8 min
Avg. Velocity = 0.69 fps, Avg. Travel Time= 40.6 min

Peak Storage= 6,609 cf @ 12.61 hrs
Average Depth at Peak Storage= 0.58' , Surface Width= 12.62'
Bank-Full Depth= 3.00' Flow Area= 93.0 sf, Capacity= 470.66 cfs

1.00' x 3.00' deep channel, n= 0.030 Earth, grassed & winding
Side Slope Z-value= 10.0 ' / ' Top Width= 61.00'
Length= 1,670.0' Slope= 0.0060 ' / '
Inlet Invert= 669.00', Outlet Invert= 659.00'

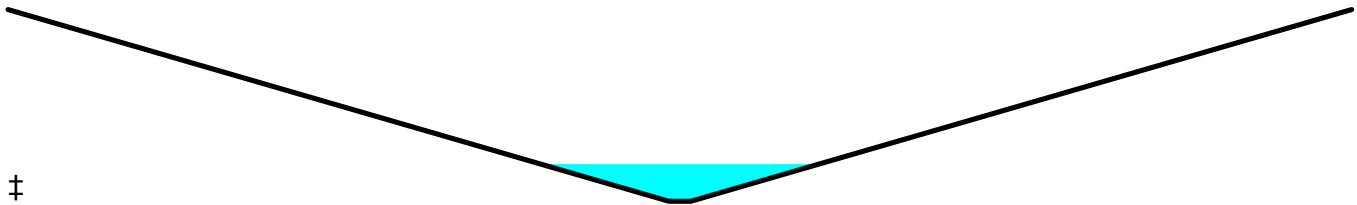

Reach 9R: North Property Line Ditch

Hydrograph

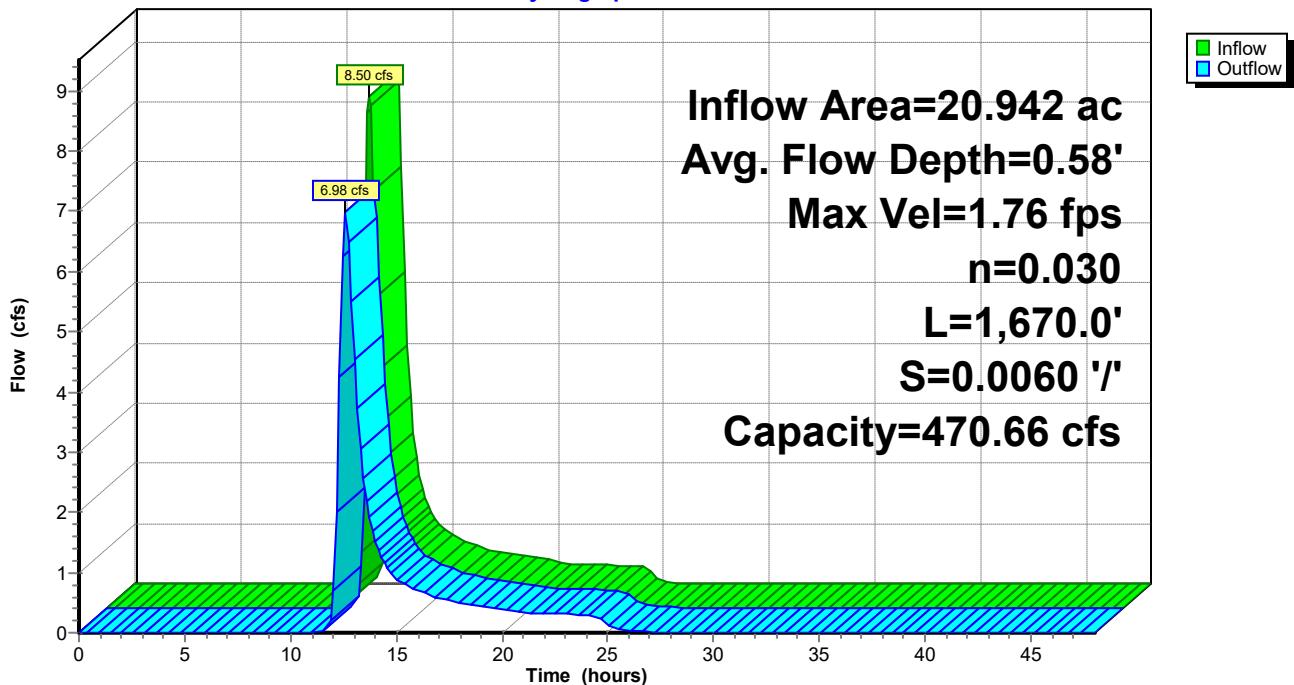

Plug Power - Existing Conditions 5-15-21

Prepared by {enter your company name here}

HydroCAD® 10.10-5a s/n 11585 © 2020 HydroCAD Software Solutions LLC

Type II 24-hr 1-yr Rainfall=1.82"

Printed 5/21/2021

Page 14

Summary for Link 10L: Total Site Discharge

Inflow Area = 29.096 ac, 0.39% Impervious, Inflow Depth = 0.62" for 1-yr event
Inflow = 9.40 cfs @ 12.52 hrs, Volume= 1.515 af
Primary = 9.40 cfs @ 12.52 hrs, Volume= 1.515 af, Atten= 0%, Lag= 0.0 min

Primary outflow = Inflow, Time Span= 0.00-48.02 hrs, dt= 0.14 hrs

Link 10L: Total Site Discharge

Hydrograph

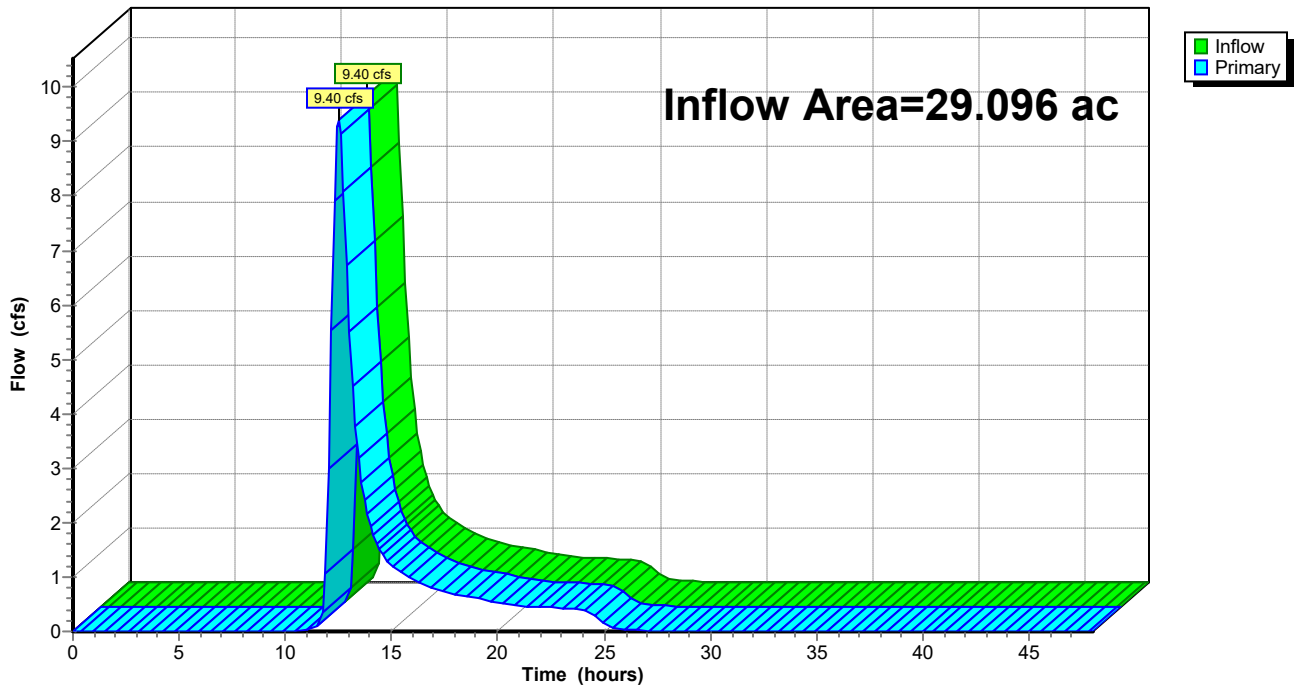

Plug Power - Existing Conditions 5-15-21

Type II 24-hr 10-yr Rainfall=3.04"

Prepared by {enter your company name here}

Printed 5/21/2021

HydroCAD® 10.10-5a s/n 11585 © 2020 HydroCAD Software Solutions LLC

Page 15

Time span=0.00-48.00 hrs, dt=0.14 hrs, 344 points x 2
Runoff by SCS TR-20 method, UH=SCS, Weighted-CN
Reach routing by Dyn-Stor-Ind method - Pond routing by Dyn-Stor-Ind method

Subcatchment 1S: Area to SW Property Runoff Area=50,330 sf 0.00% Impervious Runoff Depth=1.48"
Flow Length=130' Slope=0.0200 '/' Tc=13.9 min CN=83 Runoff=2.13 cfs 0.142 af

Subcatchment 2S: Area to SE Property Line Runoff Area=21,205 sf 0.00% Impervious Runoff Depth=1.22"
Flow Length=180' Slope=0.0150 '/' Tc=20.3 min CN=79 Runoff=0.60 cfs 0.049 af

Subcatchment 3S: Area to West Property Runoff Area=283,655 sf 0.00% Impervious Runoff Depth=1.62"
Flow Length=875' Tc=33.5 min CN=85 Runoff=8.32 cfs 0.880 af

Subcatchment 4S: Area to North Property Runoff Area=912,250 sf 0.54% Impervious Runoff Depth=1.55"
Flow Length=1,100' Tc=39.9 min CN=84 Runoff=22.88 cfs 2.704 af

Reach 9R: North Property Line Ditch Avg. Flow Depth=0.88' Max Vel=2.28 fps Inflow=22.88 cfs 2.704 af
n=0.030 L=1,670.0' S=0.0060 '/' Capacity=470.66 cfs Outflow=19.79 cfs 2.704 af

Link 10L: Total Site Discharge Inflow=26.71 cfs 3.776 af
Primary=26.71 cfs 3.776 af

Total Runoff Area = 29.096 ac Runoff Volume = 3.776 af Average Runoff Depth = 1.56"
99.61% Pervious = 28.984 ac 0.39% Impervious = 0.112 ac

Plug Power - Existing Conditions 5-15-21

Type II 24-hr 10-yr Rainfall=3.04"

Prepared by {enter your company name here}

Printed 5/21/2021

HydroCAD® 10.10-5a s/n 11585 © 2020 HydroCAD Software Solutions LLC

Page 16

Summary for Subcatchment 1S: Area to SW Property Line (Wetland)

Runoff = 2.13 cfs @ 12.06 hrs, Volume= 0.142 af, Depth= 1.48"

Runoff by SCS TR-20 method, UH=SCS, Weighted-CN, Time Span= 0.00-48.02 hrs, dt= 0.14 hrs
Type II 24-hr 10-yr Rainfall=3.04"

Area (sf)	CN	Description
31,900	85	Row crops, SR + CR, Good, HSG D
18,430	79	Woods, Fair, HSG D
50,330	83	Weighted Average
50,330		100.00% Pervious Area

Tc (min)	Length (feet)	Slope (ft/ft)	Velocity (ft/sec)	Capacity (cfs)	Description
13.2	100	0.0200	0.13		Sheet Flow, 100' Overland Flow
					Cultivated: Residue>20% n= 0.170 P2= 2.14"
0.7	30	0.0200	0.71		Shallow Concentrated Flow, 30' Shallow Conc. Flow
					Woodland Kv= 5.0 fps
13.9	130	Total			

Subcatchment 1S: Area to SW Property Line (Wetland)

Hydrograph

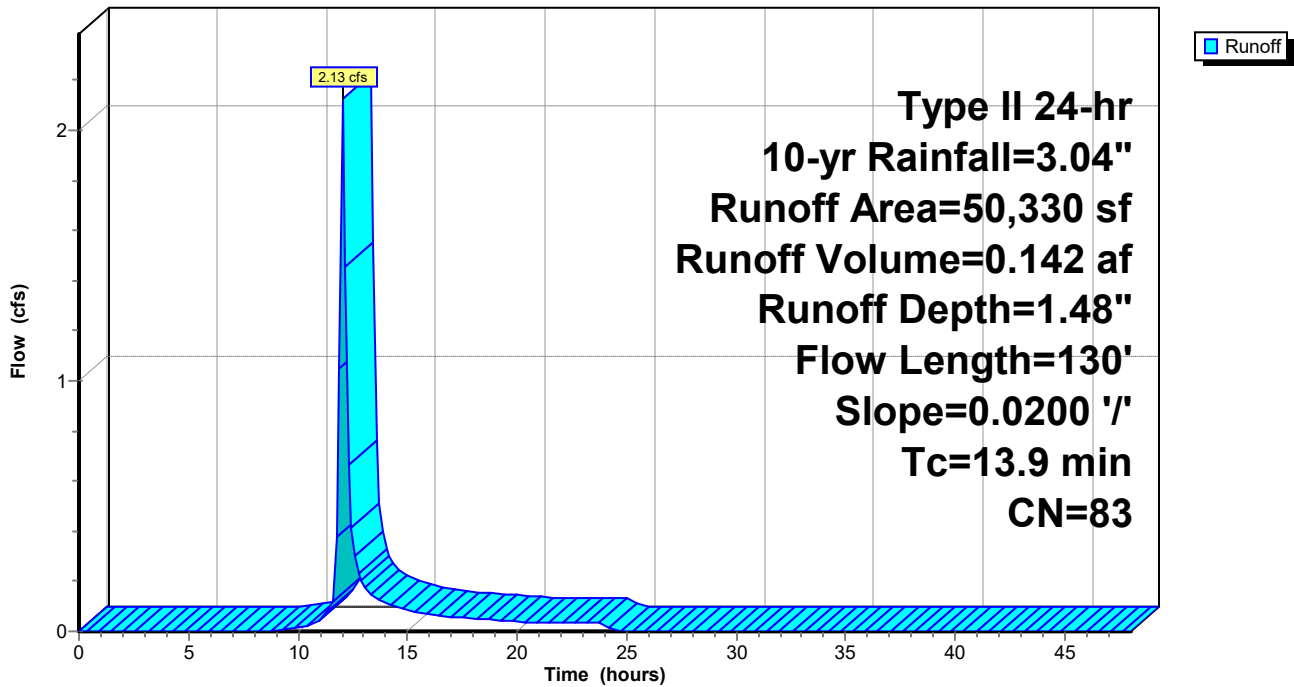

Plug Power - Existing Conditions 5-15-21

Type II 24-hr 10-yr Rainfall=3.04"

Prepared by {enter your company name here}

Printed 5/21/2021

HydroCAD® 10.10-5a s/n 11585 © 2020 HydroCAD Software Solutions LLC

Page 17

Summary for Subcatchment 2S: Area to SE Property Line

Runoff = 0.60 cfs @ 12.16 hrs, Volume= 0.049 af, Depth= 1.22"

Runoff by SCS TR-20 method, UH=SCS, Weighted-CN, Time Span= 0.00-48.02 hrs, dt= 0.14 hrs
Type II 24-hr 10-yr Rainfall=3.04"

Area (sf)	CN	Description
21,205	79	Woods/grass comb., Good, HSG D
21,205		100.00% Pervious Area

Tc (min)	Length (feet)	Slope (ft/ft)	Velocity (ft/sec)	Capacity (cfs)	Description
19.6	100	0.0150	0.09		Sheet Flow, 100' Overland Flow Grass: Dense n= 0.240 P2= 2.14"
0.7	80	0.0150	1.84		Shallow Concentrated Flow, 80' Shallow Conc. Flow Grassed Waterway Kv= 15.0 fps
20.3	180	Total			

Subcatchment 2S: Area to SE Property Line

Hydrograph

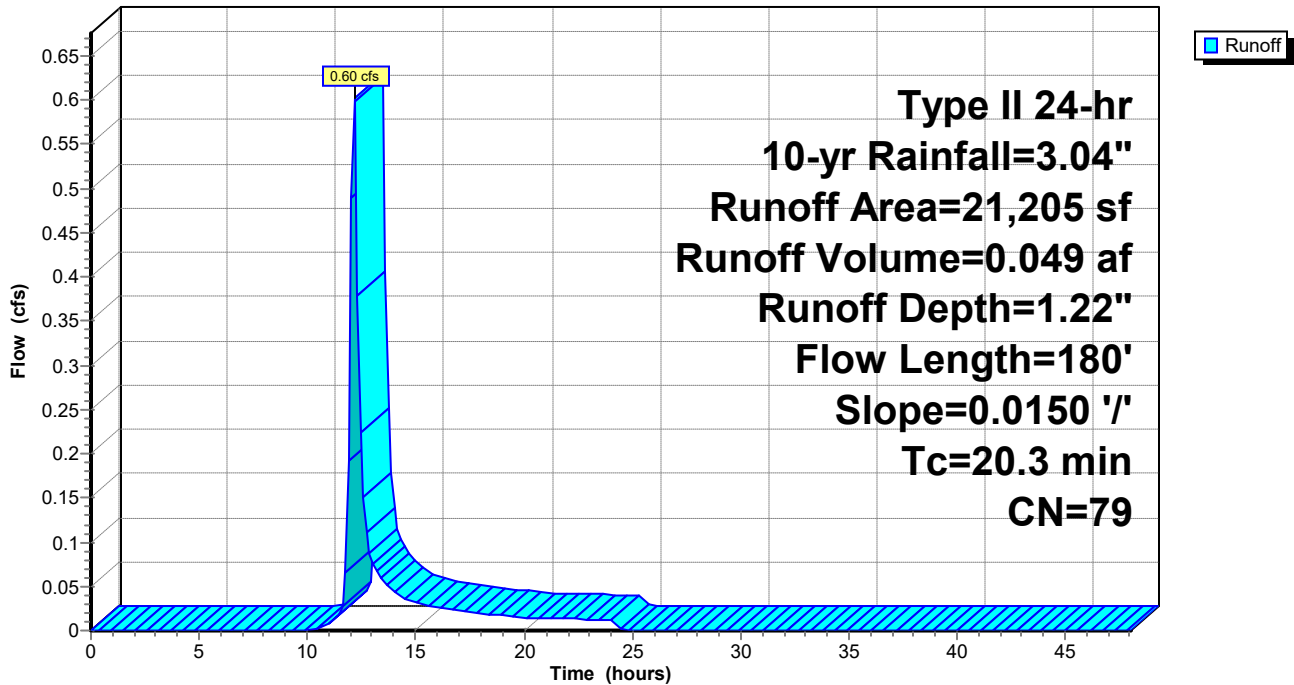

Plug Power - Existing Conditions 5-15-21

Type II 24-hr 10-yr Rainfall=3.04"

Prepared by {enter your company name here}

Printed 5/21/2021

HydroCAD® 10.10-5a s/n 11585 © 2020 HydroCAD Software Solutions LLC

Page 18

Summary for Subcatchment 3S: Area to West Property Line (Wetland)

Runoff = 8.32 cfs @ 12.30 hrs, Volume= 0.880 af, Depth= 1.62"

Runoff by SCS TR-20 method, UH=SCS, Weighted-CN, Time Span= 0.00-48.02 hrs, dt= 0.14 hrs
Type II 24-hr 10-yr Rainfall=3.04"

Area (sf)	CN	Description
283,655	85	Row crops, SR + CR, Good, HSG D
283,655		100.00% Pervious Area

Tc (min)	Length (feet)	Slope (ft/ft)	Velocity (ft/sec)	Capacity (cfs)	Description
19.1	100	0.0080	0.09		Sheet Flow, 100' Overland Flow Cultivated: Residue>20% n= 0.170 P2= 2.14"
14.4	775	0.0100	0.90		Shallow Concentrated Flow, 775' Shallow Conc. Flow Cultivated Straight Rows Kv= 9.0 fps
33.5	875	Total			

Subcatchment 3S: Area to West Property Line (Wetland)

Hydrograph

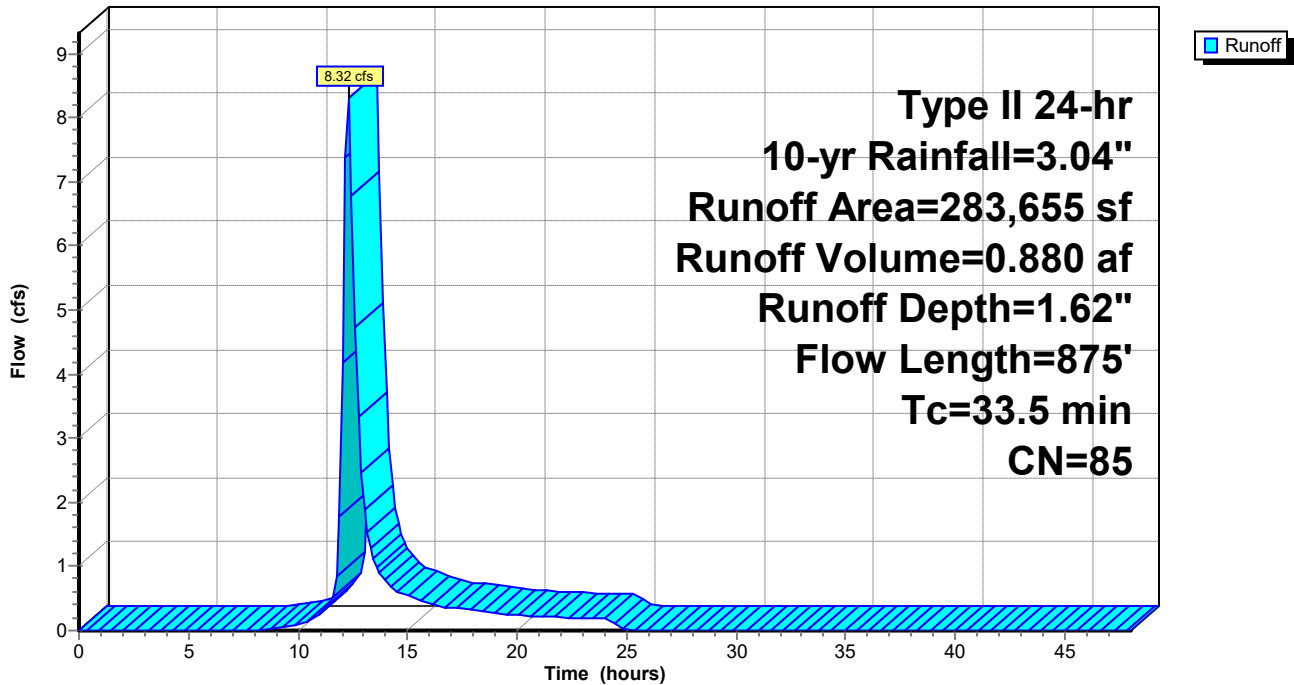

Plug Power - Existing Conditions 5-15-21

Type II 24-hr 10-yr Rainfall=3.04"

Prepared by {enter your company name here}

Printed 5/21/2021

HydroCAD® 10.10-5a s/n 11585 © 2020 HydroCAD Software Solutions LLC

Page 19

Summary for Subcatchment 4S: Area to North Property Line Ditch (Wetland)

Runoff = 22.88 cfs @ 12.38 hrs, Volume= 2.704 af, Depth= 1.55"

Runoff by SCS TR-20 method, UH=SCS, Weighted-CN, Time Span= 0.00-48.02 hrs, dt= 0.14 hrs
 Type II 24-hr 10-yr Rainfall=3.04"

Area (sf)	CN	Description
* 5,250	91	Gravel drive, HSG D
111,735	79	Woods/grass comb., Good, HSG D
4,900	98	Unconnected roofs, HSG D
62,430	77	Brush, Fair, HSG D
727,935	85	Row crops, SR + CR, Good, HSG D
912,250	84	Weighted Average
907,350		99.46% Pervious Area
4,900		0.54% Impervious Area
4,900		100.00% Unconnected

Tc (min)	Length (feet)	Slope (ft/ft)	Velocity (ft/sec)	Capacity (cfs)	Description
19.1	100	0.0080	0.09		Sheet Flow, 100' Overland Flow Cultivated: Residue>20% n= 0.170 P2= 2.14"
20.2	975	0.0080	0.80		Shallow Concentrated Flow, 975' Shallow Conc. Flow Cultivated Straight Rows Kv= 9.0 fps
0.6	25	0.0200	0.71		Shallow Concentrated Flow, 25' Shallow Conc. Flow Woodland Kv= 5.0 fps
39.9	1,100	Total			

Subcatchment 4S: Area to North Property Line Ditch (Wetland)

Hydrograph

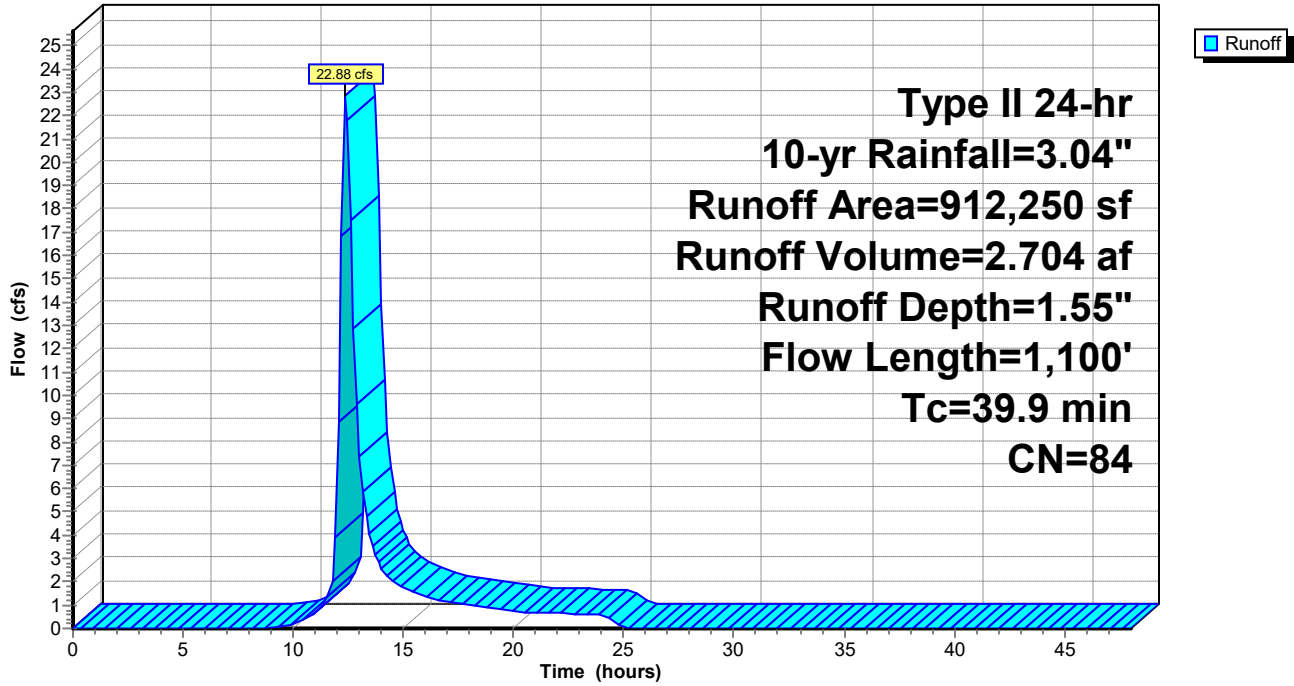

Plug Power - Existing Conditions 5-15-21

Prepared by {enter your company name here}

HydroCAD® 10.10-5a s/n 11585 © 2020 HydroCAD Software Solutions LLC

Type II 24-hr 10-yr Rainfall=3.04"

Printed 5/21/2021

Page 21

Summary for Reach 9R: North Property Line Ditch

Inflow Area = 20.942 ac, 0.54% Impervious, Inflow Depth = 1.55" for 10-yr event
Inflow = 22.88 cfs @ 12.38 hrs, Volume= 2.704 af
Outflow = 19.79 cfs @ 12.54 hrs, Volume= 2.704 af, Atten= 14%, Lag= 9.8 min

Routing by Dyn-Stor-Ind method, Time Span= 0.00-48.02 hrs, dt= 0.14 hrs / 2
Max. Velocity= 2.28 fps, Min. Travel Time= 12.2 min
Avg. Velocity = 0.80 fps, Avg. Travel Time= 34.8 min

Peak Storage= 14,430 cf @ 12.54 hrs
Average Depth at Peak Storage= 0.88' , Surface Width= 18.62'
Bank-Full Depth= 3.00' Flow Area= 93.0 sf, Capacity= 470.66 cfs

1.00' x 3.00' deep channel, n= 0.030 Earth, grassed & winding
Side Slope Z-value= 10.0 ' / ' Top Width= 61.00'
Length= 1,670.0' Slope= 0.0060 ' / '
Inlet Invert= 669.00', Outlet Invert= 659.00'

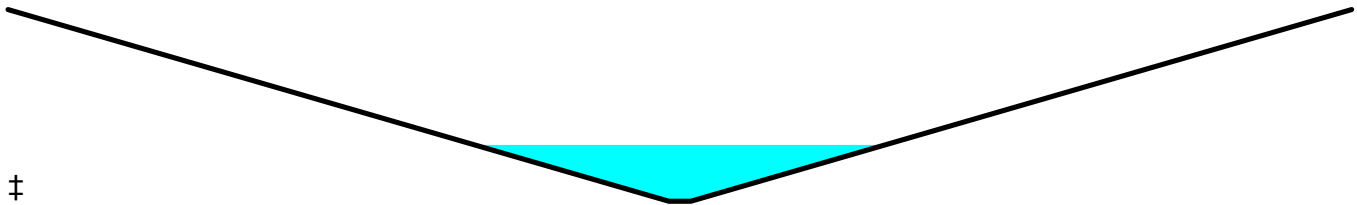

Reach 9R: North Property Line Ditch

Hydrograph

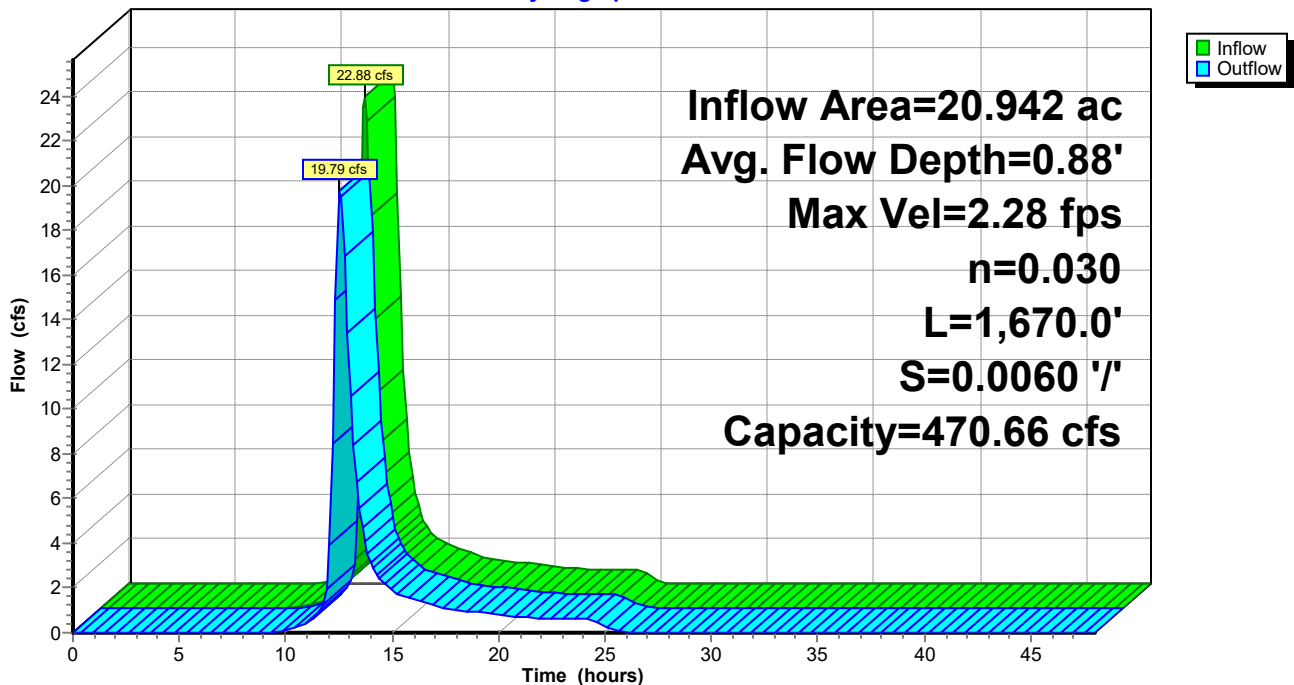

Summary for Link 10L: Total Site Discharge

Inflow Area = 29.096 ac, 0.39% Impervious, Inflow Depth = 1.56" for 10-yr event
Inflow = 26.71 cfs @ 12.47 hrs, Volume= 3.776 af
Primary = 26.71 cfs @ 12.47 hrs, Volume= 3.776 af, Atten= 0%, Lag= 0.0 min

Primary outflow = Inflow, Time Span= 0.00-48.02 hrs, dt= 0.14 hrs

Link 10L: Total Site Discharge

Hydrograph

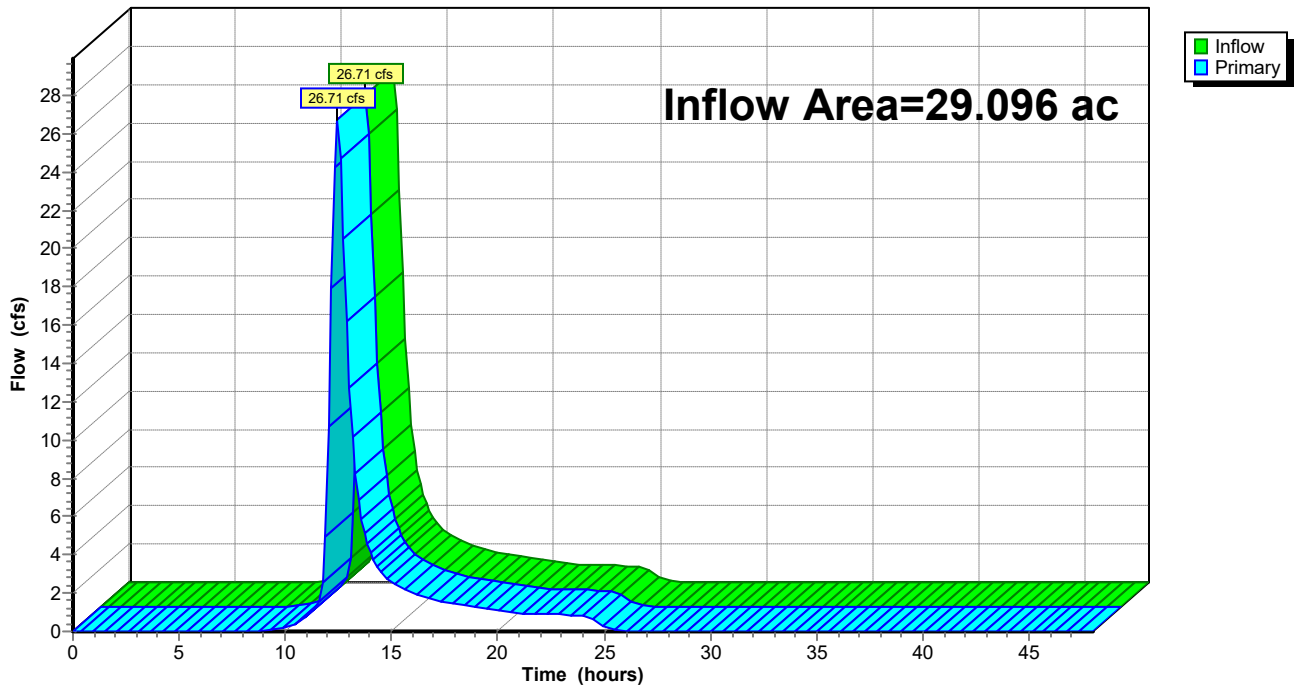

Plug Power - Existing Conditions 5-15-21

Type II 24-hr 25-yr Rainfall=3.71"

Prepared by {enter your company name here}

Printed 5/21/2021

HydroCAD® 10.10-5a s/n 11585 © 2020 HydroCAD Software Solutions LLC

Page 23

Time span=0.00-48.00 hrs, dt=0.14 hrs, 344 points x 2
Runoff by SCS TR-20 method, UH=SCS, Weighted-CN
Reach routing by Dyn-Stor-Ind method - Pond routing by Dyn-Stor-Ind method

Subcatchment 1S: Area to SW Property Runoff Area=50,330 sf 0.00% Impervious Runoff Depth=2.04"
Flow Length=130' Slope=0.0200 '/' Tc=13.9 min CN=83 Runoff=2.94 cfs 0.196 af

Subcatchment 2S: Area to SE Property Line Runoff Area=21,205 sf 0.00% Impervious Runoff Depth=1.73"
Flow Length=180' Slope=0.0150 '/' Tc=20.3 min CN=79 Runoff=0.87 cfs 0.070 af

Subcatchment 3S: Area to West Property Runoff Area=283,655 sf 0.00% Impervious Runoff Depth=2.20"
Flow Length=875' Tc=33.5 min CN=85 Runoff=11.32 cfs 1.194 af

Subcatchment 4S: Area to North Property Runoff Area=912,250 sf 0.54% Impervious Runoff Depth=2.12"
Flow Length=1,100' Tc=39.9 min CN=84 Runoff=31.48 cfs 3.695 af

Reach 9R: North Property Line Ditch Avg. Flow Depth=1.01' Max Vel=2.48 fps Inflow=31.48 cfs 3.695 af
n=0.030 L=1,670.0' S=0.0060 '/' Capacity=470.66 cfs Outflow=27.94 cfs 3.695 af

Link 10L: Total Site Discharge Inflow=37.34 cfs 5.156 af
Primary=37.34 cfs 5.156 af

Total Runoff Area = 29.096 ac Runoff Volume = 5.156 af Average Runoff Depth = 2.13"
99.61% Pervious = 28.984 ac 0.39% Impervious = 0.112 ac

Plug Power - Existing Conditions 5-15-21

Type II 24-hr 25-yr Rainfall=3.71"

Prepared by {enter your company name here}

Printed 5/21/2021

HydroCAD® 10.10-5a s/n 11585 © 2020 HydroCAD Software Solutions LLC

Page 24

Summary for Subcatchment 1S: Area to SW Property Line (Wetland)

Runoff = 2.94 cfs @ 12.05 hrs, Volume= 0.196 af, Depth= 2.04"

Runoff by SCS TR-20 method, UH=SCS, Weighted-CN, Time Span= 0.00-48.02 hrs, dt= 0.14 hrs
Type II 24-hr 25-yr Rainfall=3.71"

Area (sf)	CN	Description
31,900	85	Row crops, SR + CR, Good, HSG D
18,430	79	Woods, Fair, HSG D
50,330	83	Weighted Average
50,330		100.00% Pervious Area

Tc (min)	Length (feet)	Slope (ft/ft)	Velocity (ft/sec)	Capacity (cfs)	Description
13.2	100	0.0200	0.13		Sheet Flow, 100' Overland Flow
					Cultivated: Residue>20% n= 0.170 P2= 2.14"
0.7	30	0.0200	0.71		Shallow Concentrated Flow, 30' Shallow Conc. Flow
					Woodland Kv= 5.0 fps
13.9	130	Total			

Subcatchment 1S: Area to SW Property Line (Wetland)

Hydrograph

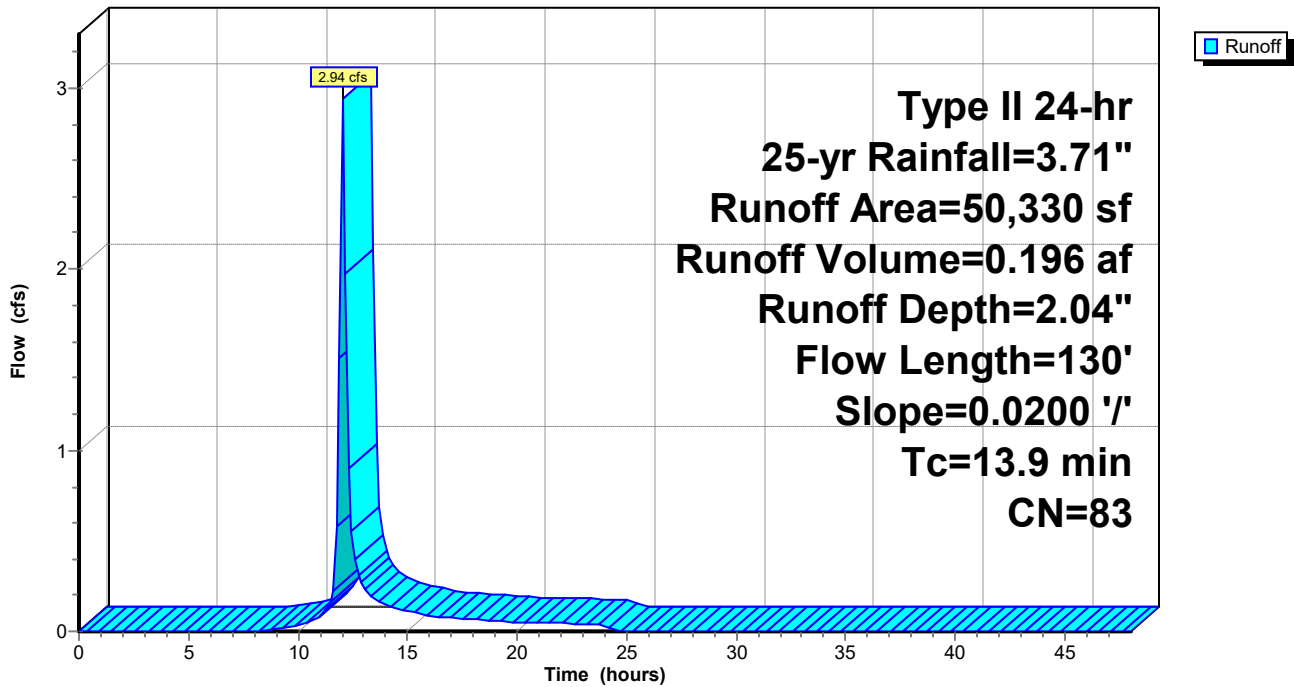

Plug Power - Existing Conditions 5-15-21

Type II 24-hr 25-yr Rainfall=3.71"

Prepared by {enter your company name here}

Printed 5/21/2021

HydroCAD® 10.10-5a s/n 11585 © 2020 HydroCAD Software Solutions LLC

Page 25

Summary for Subcatchment 2S: Area to SE Property Line

Runoff = 0.87 cfs @ 12.15 hrs, Volume= 0.070 af, Depth= 1.73"

Runoff by SCS TR-20 method, UH=SCS, Weighted-CN, Time Span= 0.00-48.02 hrs, dt= 0.14 hrs
Type II 24-hr 25-yr Rainfall=3.71"

Area (sf)	CN	Description
21,205	79	Woods/grass comb., Good, HSG D
21,205		100.00% Pervious Area

Tc (min)	Length (feet)	Slope (ft/ft)	Velocity (ft/sec)	Capacity (cfs)	Description
19.6	100	0.0150	0.09		Sheet Flow, 100' Overland Flow Grass: Dense n= 0.240 P2= 2.14"
0.7	80	0.0150	1.84		Shallow Concentrated Flow, 80' Shallow Conc. Flow Grassed Waterway Kv= 15.0 fps
20.3	180	Total			

Subcatchment 2S: Area to SE Property Line

Hydrograph

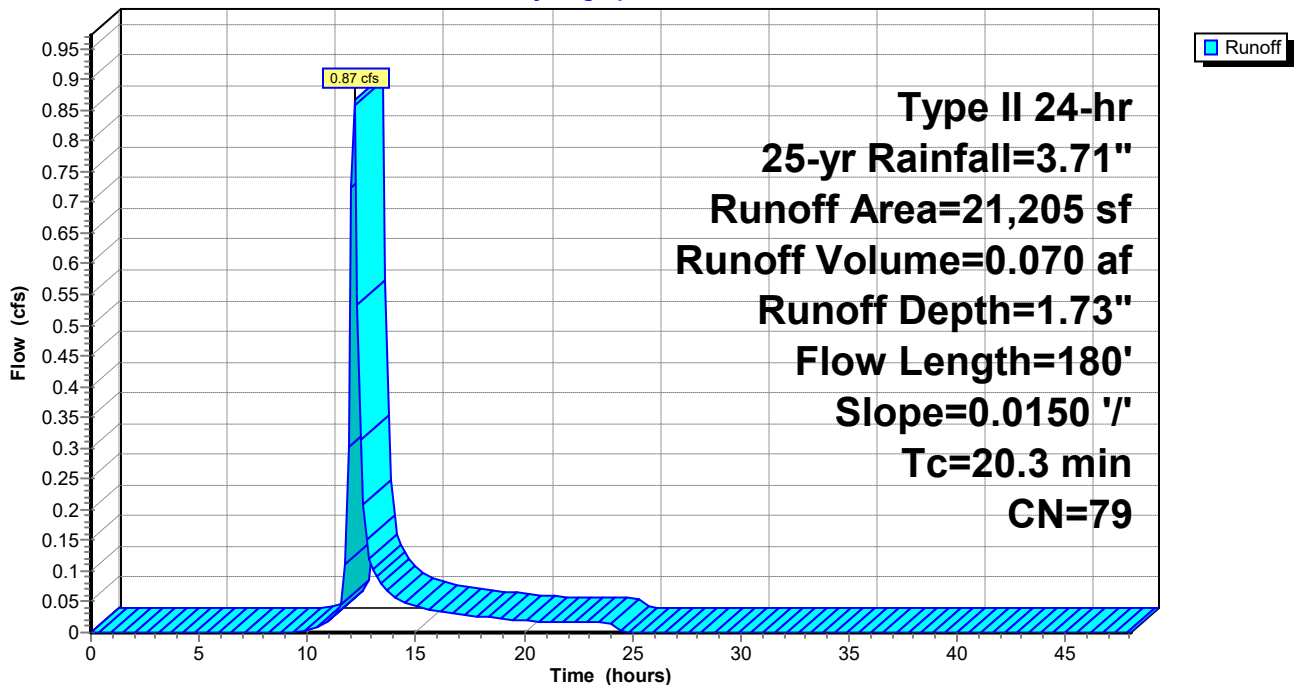

Plug Power - Existing Conditions 5-15-21

Type II 24-hr 25-yr Rainfall=3.71"

Prepared by {enter your company name here}

Printed 5/21/2021

HydroCAD® 10.10-5a s/n 11585 © 2020 HydroCAD Software Solutions LLC

Page 26

Summary for Subcatchment 3S: Area to West Property Line (Wetland)

Runoff = 11.32 cfs @ 12.30 hrs, Volume= 1.194 af, Depth= 2.20"

Runoff by SCS TR-20 method, UH=SCS, Weighted-CN, Time Span= 0.00-48.02 hrs, dt= 0.14 hrs
Type II 24-hr 25-yr Rainfall=3.71"

Area (sf)	CN	Description
283,655	85	Row crops, SR + CR, Good, HSG D
283,655		100.00% Pervious Area

Tc (min)	Length (feet)	Slope (ft/ft)	Velocity (ft/sec)	Capacity (cfs)	Description
19.1	100	0.0080	0.09		Sheet Flow, 100' Overland Flow Cultivated: Residue>20% n= 0.170 P2= 2.14"
14.4	775	0.0100	0.90		Shallow Concentrated Flow, 775' Shallow Conc. Flow Cultivated Straight Rows Kv= 9.0 fps
33.5	875	Total			

Subcatchment 3S: Area to West Property Line (Wetland)

Hydrograph

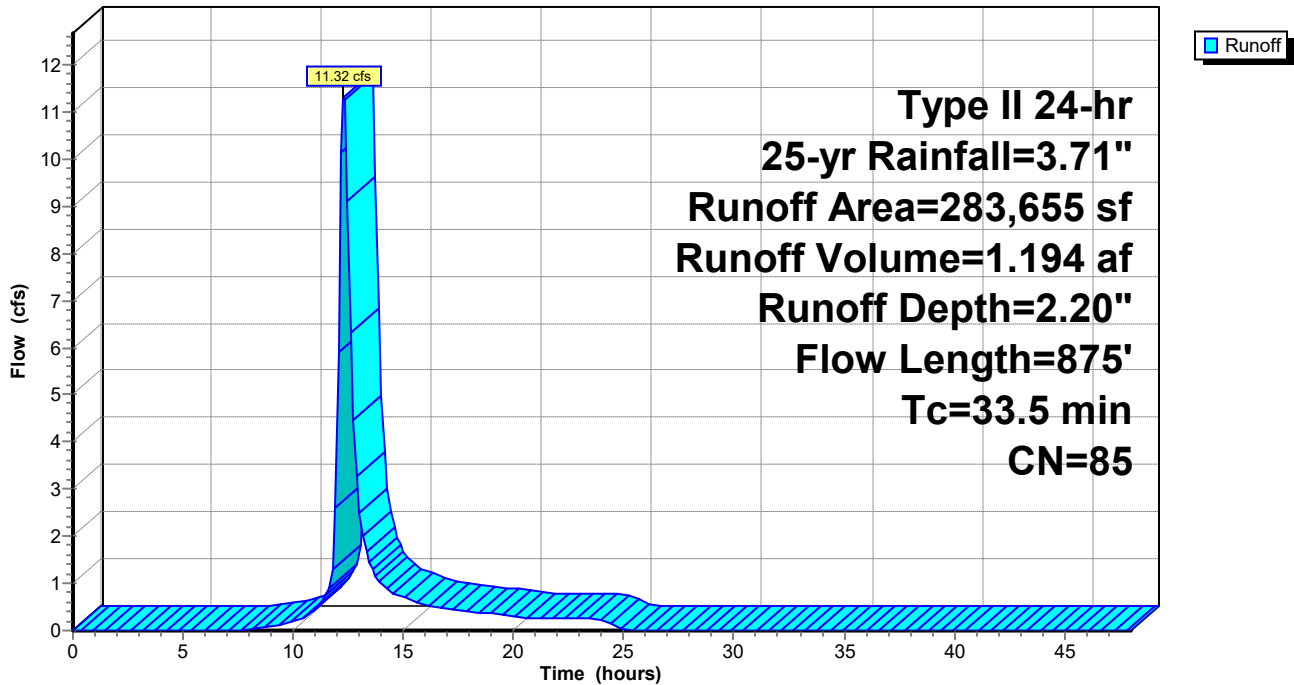

Plug Power - Existing Conditions 5-15-21

Type II 24-hr 25-yr Rainfall=3.71"

Prepared by {enter your company name here}

Printed 5/21/2021

HydroCAD® 10.10-5a s/n 11585 © 2020 HydroCAD Software Solutions LLC

Page 27

Summary for Subcatchment 4S: Area to North Property Line Ditch (Wetland)

Runoff = 31.48 cfs @ 12.37 hrs, Volume= 3.695 af, Depth= 2.12"

Runoff by SCS TR-20 method, UH=SCS, Weighted-CN, Time Span= 0.00-48.02 hrs, dt= 0.14 hrs
 Type II 24-hr 25-yr Rainfall=3.71"

Area (sf)	CN	Description
* 5,250	91	Gravel drive, HSG D
111,735	79	Woods/grass comb., Good, HSG D
4,900	98	Unconnected roofs, HSG D
62,430	77	Brush, Fair, HSG D
727,935	85	Row crops, SR + CR, Good, HSG D
912,250	84	Weighted Average
907,350		99.46% Pervious Area
4,900		0.54% Impervious Area
4,900		100.00% Unconnected

Tc (min)	Length (feet)	Slope (ft/ft)	Velocity (ft/sec)	Capacity (cfs)	Description
19.1	100	0.0080	0.09		Sheet Flow, 100' Overland Flow Cultivated: Residue>20% n= 0.170 P2= 2.14"
20.2	975	0.0080	0.80		Shallow Concentrated Flow, 975' Shallow Conc. Flow Cultivated Straight Rows Kv= 9.0 fps
0.6	25	0.0200	0.71		Shallow Concentrated Flow, 25' Shallow Conc. Flow Woodland Kv= 5.0 fps
39.9	1,100	Total			

Subcatchment 4S: Area to North Property Line Ditch (Wetland)

Hydrograph

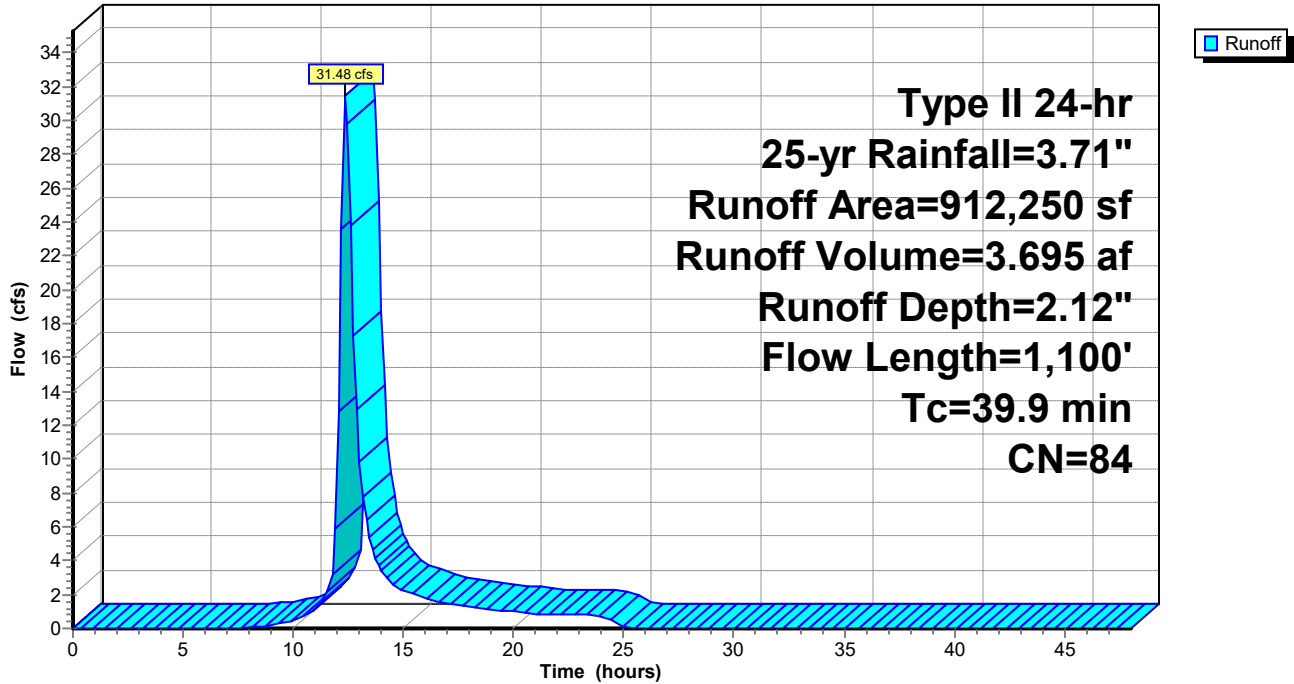

Plug Power - Existing Conditions 5-15-21

Prepared by {enter your company name here}

HydroCAD® 10.10-5a s/n 11585 © 2020 HydroCAD Software Solutions LLC

Type II 24-hr 25-yr Rainfall=3.71"

Printed 5/21/2021

Page 29

Summary for Reach 9R: North Property Line Ditch

Inflow Area = 20.942 ac, 0.54% Impervious, Inflow Depth = 2.12" for 25-yr event
Inflow = 31.48 cfs @ 12.37 hrs, Volume= 3.695 af
Outflow = 27.94 cfs @ 12.52 hrs, Volume= 3.695 af, Atten= 11%, Lag= 9.0 min

Routing by Dyn-Stor-Ind method, Time Span= 0.00-48.02 hrs, dt= 0.14 hrs / 2
Max. Velocity= 2.48 fps, Min. Travel Time= 11.2 min
Avg. Velocity = 0.85 fps, Avg. Travel Time= 32.9 min

Peak Storage= 18,695 cf @ 12.52 hrs
Average Depth at Peak Storage= 1.01' , Surface Width= 21.19'
Bank-Full Depth= 3.00' Flow Area= 93.0 sf, Capacity= 470.66 cfs

1.00' x 3.00' deep channel, n= 0.030 Earth, grassed & winding
Side Slope Z-value= 10.0 ' / ' Top Width= 61.00'
Length= 1,670.0' Slope= 0.0060 ' / '
Inlet Invert= 669.00', Outlet Invert= 659.00'

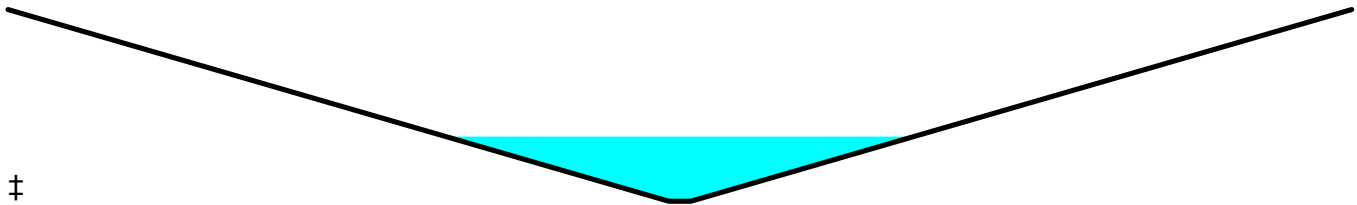

Reach 9R: North Property Line Ditch

Hydrograph

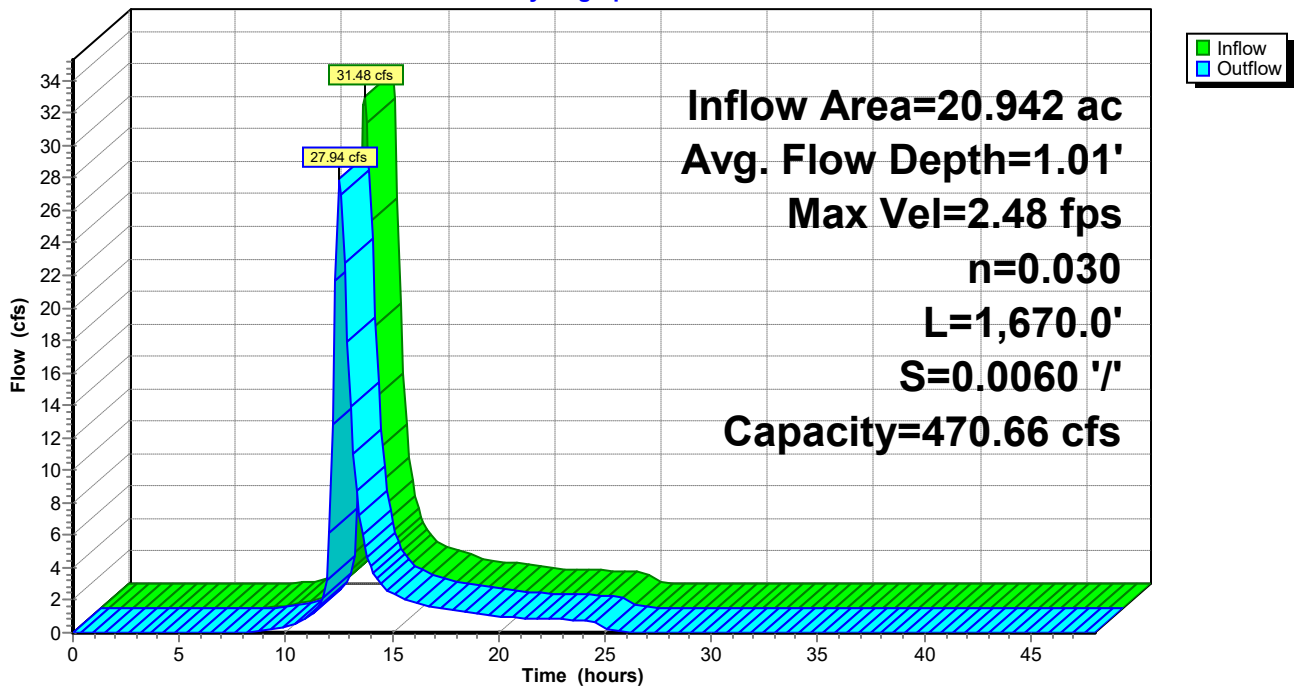

Summary for Link 10L: Total Site Discharge

Inflow Area = 29.096 ac, 0.39% Impervious, Inflow Depth = 2.13" for 25-yr event
Inflow = 37.34 cfs @ 12.45 hrs, Volume= 5.156 af
Primary = 37.34 cfs @ 12.45 hrs, Volume= 5.156 af, Atten= 0%, Lag= 0.0 min

Primary outflow = Inflow, Time Span= 0.00-48.02 hrs, dt= 0.14 hrs

Link 10L: Total Site Discharge

Hydrograph

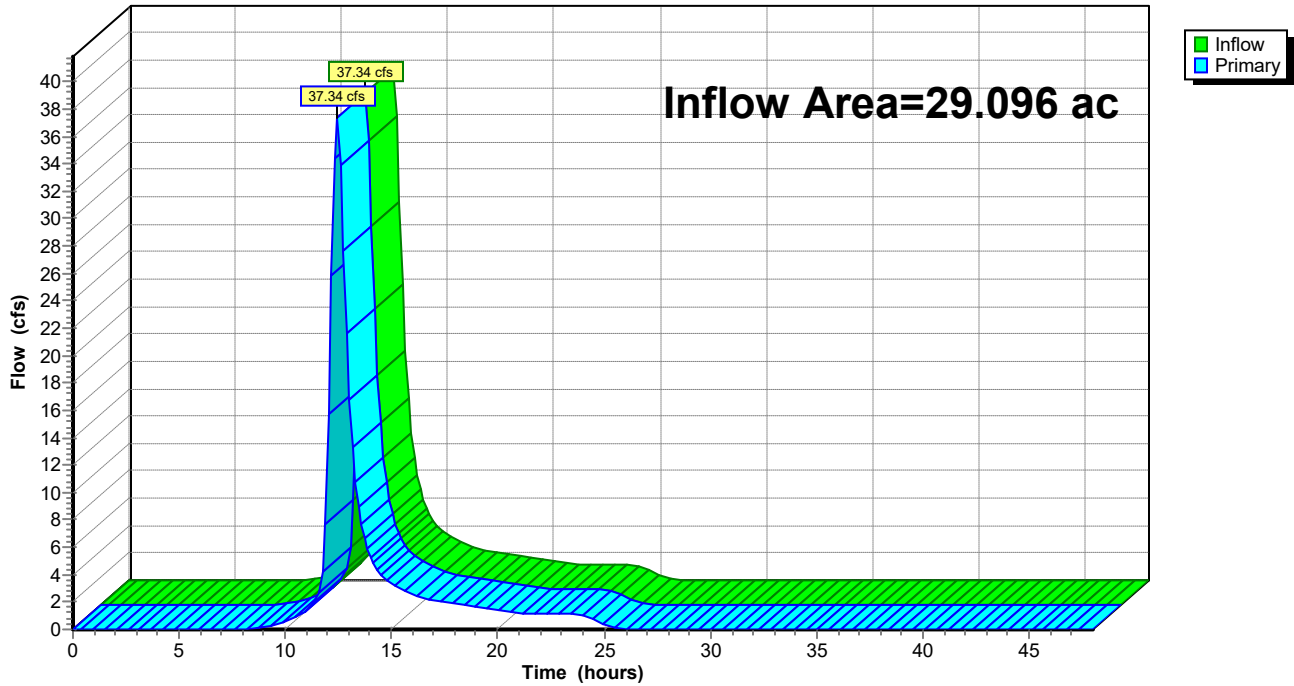

Plug Power - Existing Conditions 5-15-21

Type II 24-hr 100-yr Rainfall=5.01"

Prepared by {enter your company name here}

Printed 5/21/2021

HydroCAD® 10.10-5a s/n 11585 © 2020 HydroCAD Software Solutions LLC

Page 31

Time span=0.00-48.00 hrs, dt=0.14 hrs, 344 points x 2
Runoff by SCS TR-20 method, UH=SCS, Weighted-CN
Reach routing by Dyn-Stor-Ind method - Pond routing by Dyn-Stor-Ind method

Subcatchment 1S: Area to SW Property Runoff Area=50,330 sf 0.00% Impervious Runoff Depth=3.18"
Flow Length=130' Slope=0.0200 '/' Tc=13.9 min CN=83 Runoff=4.58 cfs 0.306 af

Subcatchment 2S: Area to SE Property Line Runoff Area=21,205 sf 0.00% Impervious Runoff Depth=2.81"
Flow Length=180' Slope=0.0150 '/' Tc=20.3 min CN=79 Runoff=1.41 cfs 0.114 af

Subcatchment 3S: Area to West Property Runoff Area=283,655 sf 0.00% Impervious Runoff Depth=3.38"
Flow Length=875' Tc=33.5 min CN=85 Runoff=17.29 cfs 1.833 af

Subcatchment 4S: Area to North Property Runoff Area=912,250 sf 0.54% Impervious Runoff Depth=3.28"
Flow Length=1,100' Tc=39.9 min CN=84 Runoff=48.76 cfs 5.723 af

Reach 9R: North Property Line Ditch Avg. Flow Depth=1.21' Max Vel=2.79 fps Inflow=48.76 cfs 5.723 af
n=0.030 L=1,670.0' S=0.0060 '/' Capacity=470.66 cfs Outflow=44.19 cfs 5.723 af

Link 10L: Total Site Discharge Inflow=58.95 cfs 7.977 af
Primary=58.95 cfs 7.977 af

Total Runoff Area = 29.096 ac Runoff Volume = 7.977 af Average Runoff Depth = 3.29"
99.61% Pervious = 28.984 ac 0.39% Impervious = 0.112 ac

Plug Power - Existing Conditions 5-15-21

Type II 24-hr 100-yr Rainfall=5.01"

Prepared by {enter your company name here}

Printed 5/21/2021

HydroCAD® 10.10-5a s/n 11585 © 2020 HydroCAD Software Solutions LLC

Page 32

Summary for Subcatchment 1S: Area to SW Property Line (Wetland)

Runoff = 4.58 cfs @ 12.05 hrs, Volume= 0.306 af, Depth= 3.18"

Runoff by SCS TR-20 method, UH=SCS, Weighted-CN, Time Span= 0.00-48.02 hrs, dt= 0.14 hrs
Type II 24-hr 100-yr Rainfall=5.01"

Area (sf)	CN	Description
31,900	85	Row crops, SR + CR, Good, HSG D
18,430	79	Woods, Fair, HSG D
50,330	83	Weighted Average
50,330		100.00% Pervious Area

Tc (min)	Length (feet)	Slope (ft/ft)	Velocity (ft/sec)	Capacity (cfs)	Description
13.2	100	0.0200	0.13		Sheet Flow, 100' Overland Flow
					Cultivated: Residue>20% n= 0.170 P2= 2.14"
0.7	30	0.0200	0.71		Shallow Concentrated Flow, 30' Shallow Conc. Flow
					Woodland Kv= 5.0 fps
13.9	130	Total			

Subcatchment 1S: Area to SW Property Line (Wetland)

Hydrograph

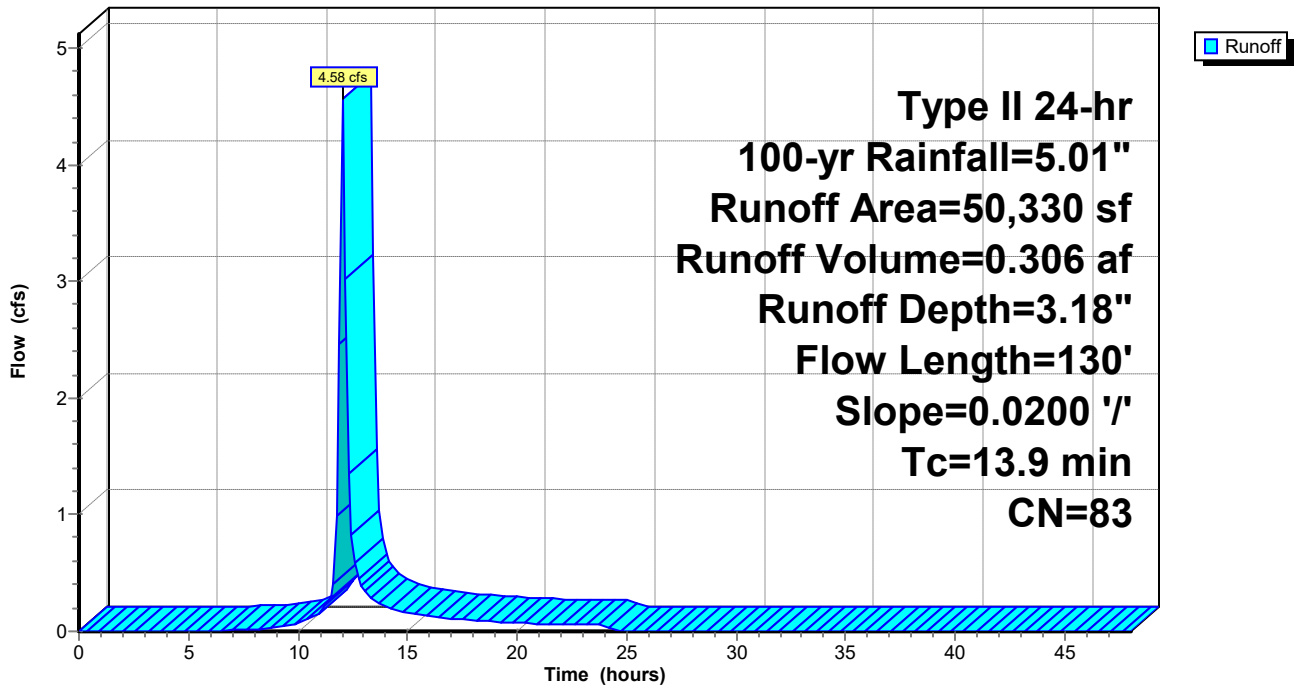

Plug Power - Existing Conditions 5-15-21

Type II 24-hr 100-yr Rainfall=5.01"

Prepared by {enter your company name here}

Printed 5/21/2021

HydroCAD® 10.10-5a s/n 11585 © 2020 HydroCAD Software Solutions LLC

Page 33

Summary for Subcatchment 2S: Area to SE Property Line

Runoff = 1.41 cfs @ 12.14 hrs, Volume= 0.114 af, Depth= 2.81"

Runoff by SCS TR-20 method, UH=SCS, Weighted-CN, Time Span= 0.00-48.02 hrs, dt= 0.14 hrs
Type II 24-hr 100-yr Rainfall=5.01"

Area (sf)	CN	Description
21,205	79	Woods/grass comb., Good, HSG D
21,205		100.00% Pervious Area

Tc (min)	Length (feet)	Slope (ft/ft)	Velocity (ft/sec)	Capacity (cfs)	Description
19.6	100	0.0150	0.09		Sheet Flow, 100' Overland Flow Grass: Dense n= 0.240 P2= 2.14"
0.7	80	0.0150	1.84		Shallow Concentrated Flow, 80' Shallow Conc. Flow Grassed Waterway Kv= 15.0 fps
20.3	180	Total			

Subcatchment 2S: Area to SE Property Line

Hydrograph

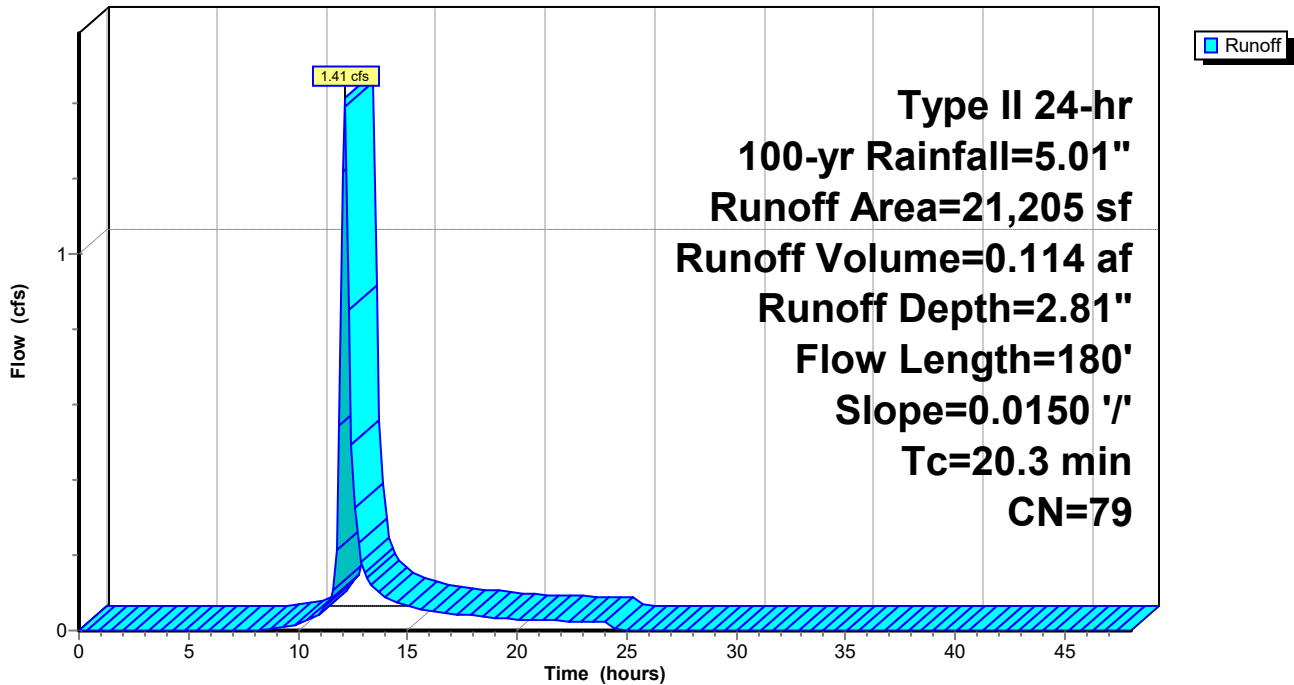

Plug Power - Existing Conditions 5-15-21

Prepared by {enter your company name here}

HydroCAD® 10.10-5a s/n 11585 © 2020 HydroCAD Software Solutions LLC

Type II 24-hr 100-yr Rainfall=5.01"

Printed 5/21/2021

Page 34

Summary for Subcatchment 3S: Area to West Property Line (Wetland)

Runoff = 17.29 cfs @ 12.29 hrs, Volume= 1.833 af, Depth= 3.38"

Runoff by SCS TR-20 method, UH=SCS, Weighted-CN, Time Span= 0.00-48.02 hrs, dt= 0.14 hrs
Type II 24-hr 100-yr Rainfall=5.01"

Area (sf)	CN	Description
283,655	85	Row crops, SR + CR, Good, HSG D
283,655		100.00% Pervious Area

Tc (min)	Length (feet)	Slope (ft/ft)	Velocity (ft/sec)	Capacity (cfs)	Description
19.1	100	0.0080	0.09		Sheet Flow, 100' Overland Flow
					Cultivated: Residue>20% n= 0.170 P2= 2.14"
14.4	775	0.0100	0.90		Shallow Concentrated Flow, 775' Shallow Conc. Flow
					Cultivated Straight Rows Kv= 9.0 fps
33.5	875	Total			

Subcatchment 3S: Area to West Property Line (Wetland)

Hydrograph

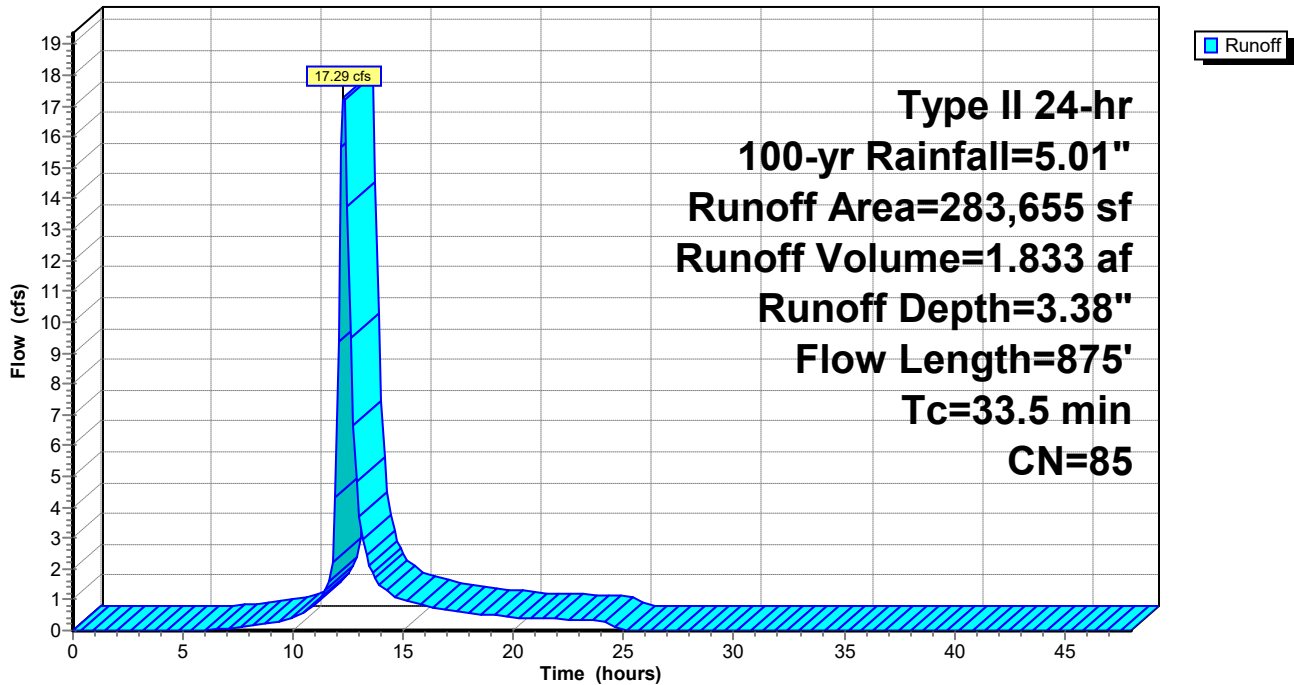

Plug Power - Existing Conditions 5-15-21

Type II 24-hr 100-yr Rainfall=5.01"

Prepared by {enter your company name here}

Printed 5/21/2021

HydroCAD® 10.10-5a s/n 11585 © 2020 HydroCAD Software Solutions LLC

Page 35

Summary for Subcatchment 4S: Area to North Property Line Ditch (Wetland)

Runoff = 48.76 cfs @ 12.37 hrs, Volume= 5.723 af, Depth= 3.28"

Runoff by SCS TR-20 method, UH=SCS, Weighted-CN, Time Span= 0.00-48.02 hrs, dt= 0.14 hrs
Type II 24-hr 100-yr Rainfall=5.01"

Area (sf)	CN	Description
* 5,250	91	Gravel drive, HSG D
111,735	79	Woods/grass comb., Good, HSG D
4,900	98	Unconnected roofs, HSG D
62,430	77	Brush, Fair, HSG D
727,935	85	Row crops, SR + CR, Good, HSG D
912,250	84	Weighted Average
907,350		99.46% Pervious Area
4,900		0.54% Impervious Area
4,900		100.00% Unconnected

Tc (min)	Length (feet)	Slope (ft/ft)	Velocity (ft/sec)	Capacity (cfs)	Description
19.1	100	0.0080	0.09		Sheet Flow, 100' Overland Flow Cultivated: Residue>20% n= 0.170 P2= 2.14"
20.2	975	0.0080	0.80		Shallow Concentrated Flow, 975' Shallow Conc. Flow Cultivated Straight Rows Kv= 9.0 fps
0.6	25	0.0200	0.71		Shallow Concentrated Flow, 25' Shallow Conc. Flow Woodland Kv= 5.0 fps
39.9	1,100	Total			

Subcatchment 4S: Area to North Property Line Ditch (Wetland)

Hydrograph

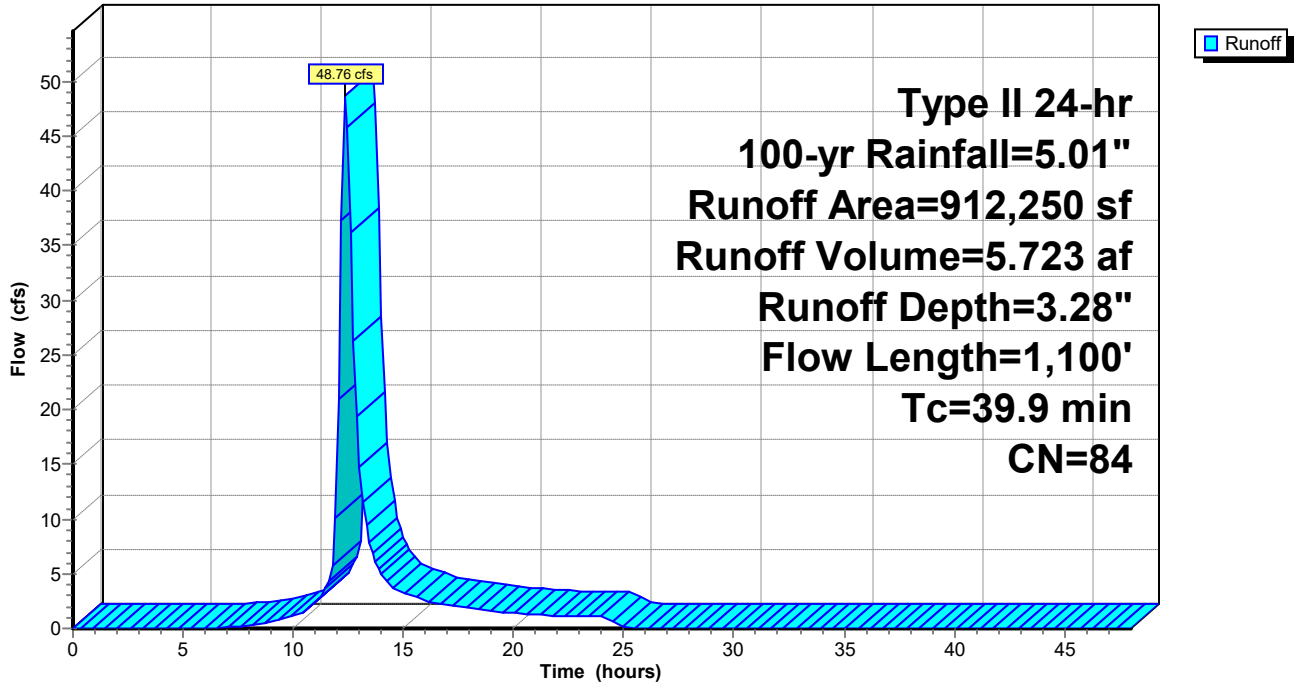

Plug Power - Existing Conditions 5-15-21

Prepared by {enter your company name here}

HydroCAD® 10.10-5a s/n 11585 © 2020 HydroCAD Software Solutions LLC

Type II 24-hr 100-yr Rainfall=5.01"

Printed 5/21/2021

Page 37

Summary for Reach 9R: North Property Line Ditch

Inflow Area = 20.942 ac, 0.54% Impervious, Inflow Depth = 3.28" for 100-yr event
Inflow = 48.76 cfs @ 12.37 hrs, Volume= 5.723 af
Outflow = 44.19 cfs @ 12.50 hrs, Volume= 5.723 af, Atten= 9%, Lag= 8.2 min

Routing by Dyn-Stor-Ind method, Time Span= 0.00-48.02 hrs, dt= 0.14 hrs / 2
Max. Velocity= 2.79 fps, Min. Travel Time= 10.0 min
Avg. Velocity = 0.92 fps, Avg. Travel Time= 30.1 min

Peak Storage= 26,358 cf @ 12.50 hrs
Average Depth at Peak Storage= 1.21' , Surface Width= 25.15'
Bank-Full Depth= 3.00' Flow Area= 93.0 sf, Capacity= 470.66 cfs

1.00' x 3.00' deep channel, n= 0.030 Earth, grassed & winding
Side Slope Z-value= 10.0 ' ' Top Width= 61.00'
Length= 1,670.0' Slope= 0.0060 ' '
Inlet Invert= 669.00', Outlet Invert= 659.00'

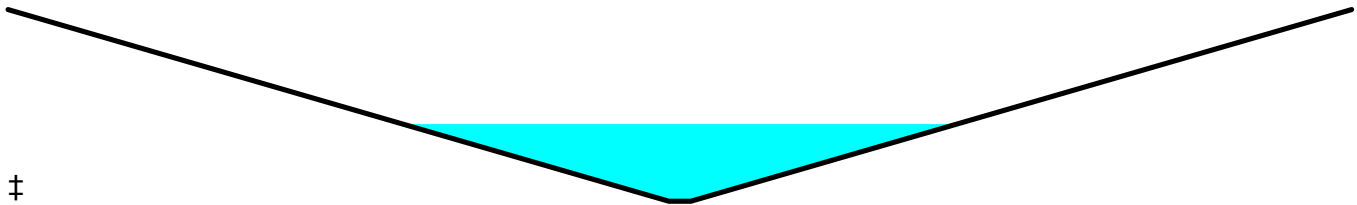

Reach 9R: North Property Line Ditch

Hydrograph

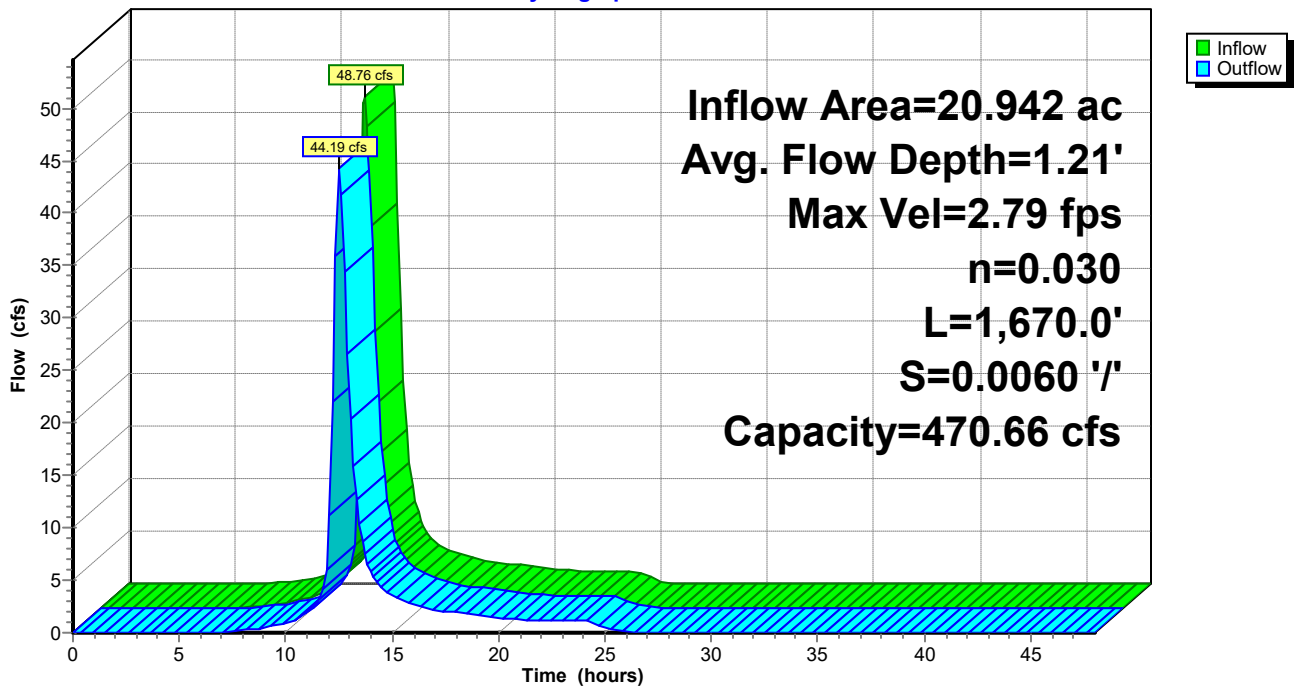

Summary for Link 10L: Total Site Discharge

Inflow Area = 29.096 ac, 0.39% Impervious, Inflow Depth = 3.29" for 100-yr event
Inflow = 58.95 cfs @ 12.44 hrs, Volume= 7.977 af
Primary = 58.95 cfs @ 12.44 hrs, Volume= 7.977 af, Atten= 0%, Lag= 0.0 min

Primary outflow = Inflow, Time Span= 0.00-48.02 hrs, dt= 0.14 hrs

Link 10L: Total Site Discharge

Hydrograph

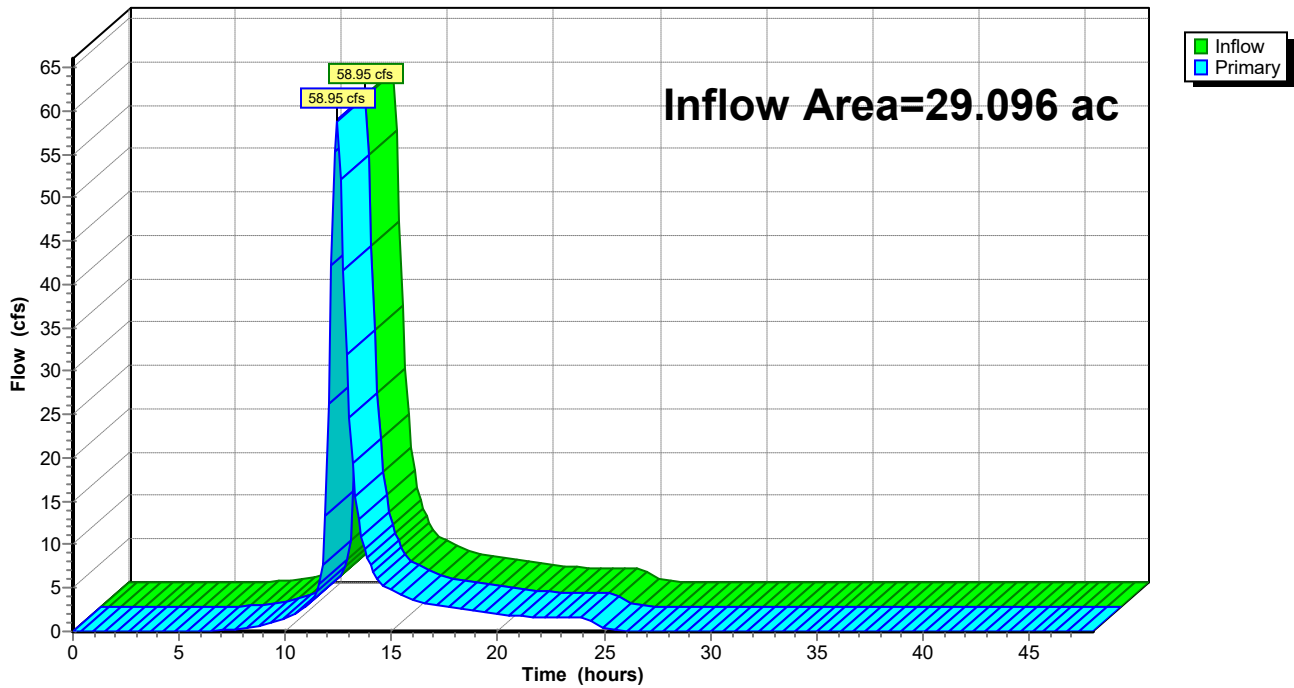

Appendix A-2

Drainage Calculations

Proposed Conditions

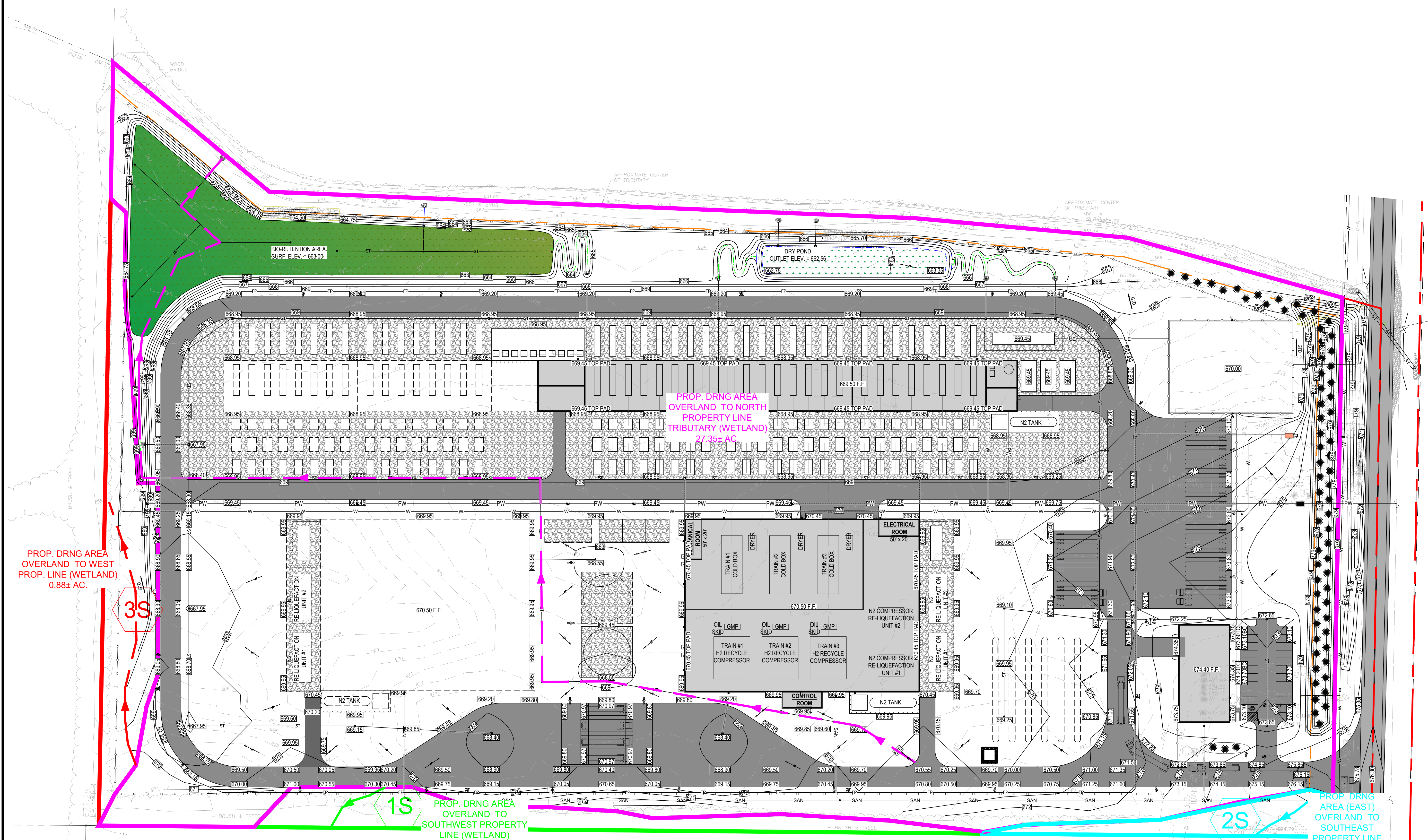

PROP. DRNG AREA
OVERLAND TO NORTH
PROPERTY LINE
TRIBUTARY (WETLAND)
27.35± AC.

PROP. DRNG AREA
OVERLAND TO WEST
PROP. LINE (WETLAND)
0.88± AC.

PROP. DRNG AREA
OVERLAND TO
SOUTHWEST PROPERTY
LINE (WETLAND)
0.59± AC.

PROP. DRNG
AREA (EAST)
OVERLAND TO
SOUTHEAST
PROPERTY LINE
0.29± AC.

PROPOSED CONDITIONS DRAINAGE MAP
SCALE: 1"=60'

NO.	ISSUE DATE	REVISION DESCRIPTION
0	05-15-2021	SITE PLAN SUBMITTAL
1		
2		
3		
4		
5		
6		
7		
8		
9		

CLIENT:
PLUG POWER
968 ALBANY SHAKER ROAD
LATHAM, NY 12110

PROJECT:
PLUG POWER HYDROGEN
PRODUCTION FACILITY



4759 N 5th Street
Lewiston, NY 14092
Phone: (716) 946-2415
Email: rhaight@invictuscivilengineering.com

SEAL / SIGNATURE

Following is an excerpt from the New York State Education Law, Article 145, Section 7209.4, which applies to this drawing. It is a violation of this law for any person unless he is acting under the direct supervision of a licensed professional engineer to alter an item in any way, if an item bearing the seal of a professional engineer is altered, the altering engineer shall affix his seal and the notation "ALTERED BY" followed by his signature and date of such alteration and a specific description of the alteration. This drawing is copyrighted under the United States Copyright Law and is the property of Invictus Civil Engineering, P.C. The use of this drawing in any form without written permission is strictly prohibited.

SHEET TITLE:
**PROPOSED CONDITIONS
DRAINAGE MAP**

SHEET
DR-001

SCALE AS NOTED PROJECT # 21-1002 DATE 05/15/2021

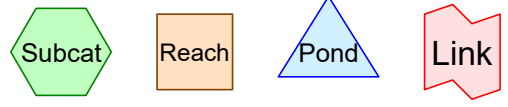
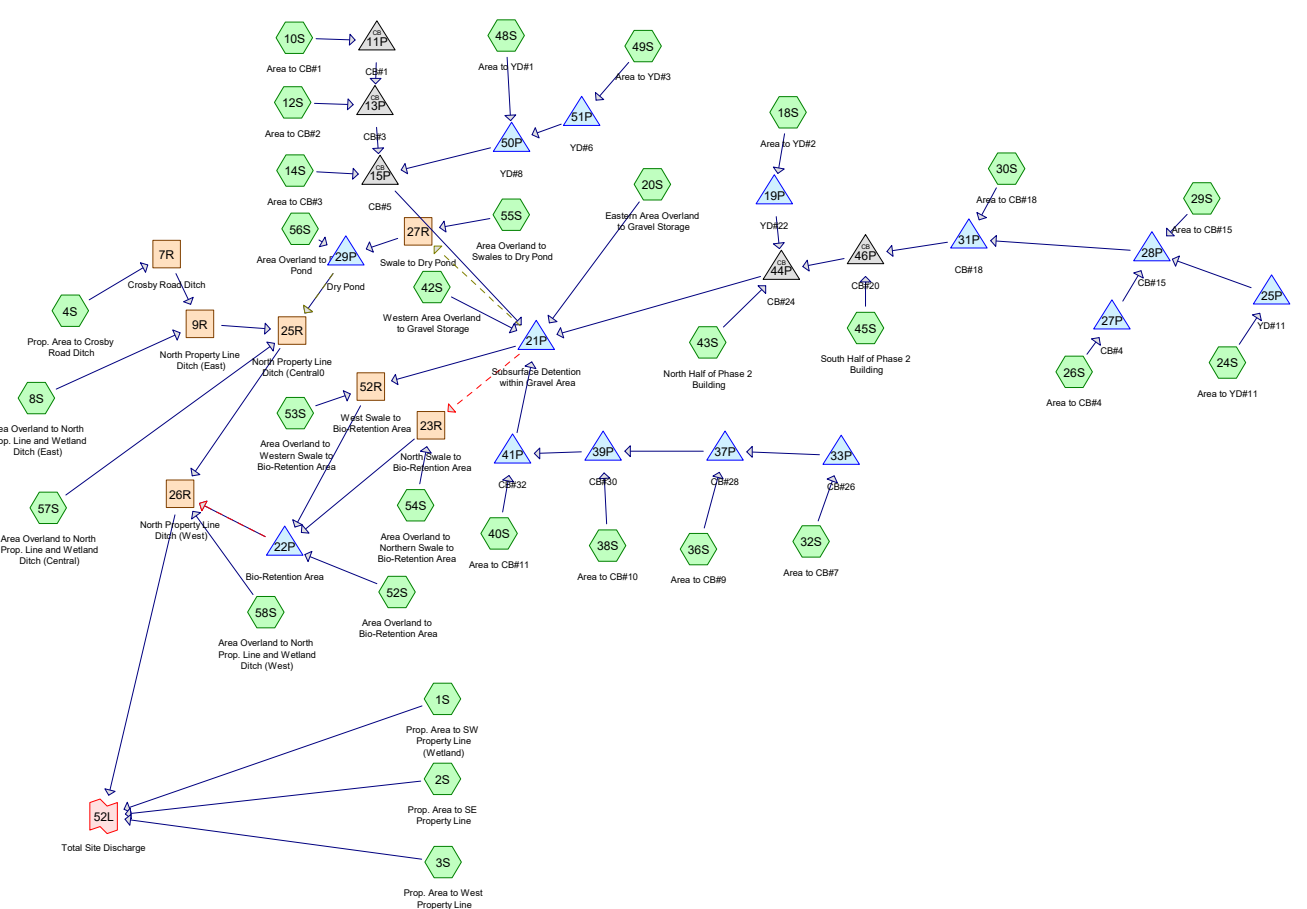

Routing Diagram for Plug Power - Proposed Conditions 5-15-21
Prepared by {enter your company name here}, Printed 5/20/2021
HydroCAD® 10.10-5a s/n 11585 © 2020 HydroCAD Software Solutions LLC

Plug Power - Proposed Conditions 5-15-21

Prepared by {enter your company name here}

HydroCAD® 10.10-5a s/n 11585 © 2020 HydroCAD Software Solutions LLC

Printed 5/20/2021

Page 2

Project Notes

Defined 9 rainfall events from Gateway IDF

Plug Power - Proposed Conditions 5-15-21

Prepared by {enter your company name here}

HydroCAD® 10.10-5a s/n 11585 © 2020 HydroCAD Software Solutions LLC

Printed 5/20/2021

Page 3

Rainfall Events Listing (selected events)

Event#	Event Name	Storm Type	Curve	Mode	Duration (hours)	B/B	Depth (inches)	AMC
1	1-yr	Type II 24-hr		Default	24.00	1	1.82	2
2	10-yr	Type II 24-hr		Default	24.00	1	3.04	2
3	25-yr	Type II 24-hr		Default	24.00	1	3.71	2

Plug Power - Proposed Conditions 5-15-21

Prepared by {enter your company name here}

HydroCAD® 10.10-5a s/n 11585 © 2020 HydroCAD Software Solutions LLC

Printed 5/20/2021

Page 4

Area Listing (all nodes)

Area (acres)	CN	Description (subcatchment-numbers)
9.685	80	>75% Grass cover, Good, HSG D (1S, 3S, 10S, 12S, 14S, 18S, 20S, 24S, 26S, 30S, 32S, 36S, 38S, 42S, 48S, 49S, 52S, 53S, 54S, 55S, 56S)
2.105	77	Brush, Fair, HSG D (8S, 57S, 58S)
3.004	80	Gravel Storage Area, Good, HSG D (20S, 42S)
0.667	78	Meadow, non-grazed, HSG D (1S, 3S, 38S)
5.945	98	Paved parking, HSG D (10S, 12S, 14S, 20S, 24S, 26S, 32S, 36S, 38S, 40S, 42S, 48S, 49S)
5.115	98	Roofs, HSG D (10S, 12S, 20S, 24S, 26S, 29S, 42S, 43S, 45S, 48S, 49S)
1.449	98	Unconnected pavement, HSG D (18S, 20S, 30S, 36S, 42S)
0.610	79	Woods, Fair, HSG D (1S, 38S)
0.516	79	Woods/grass comb., Good, HSG D (2S, 4S)
29.096	87	TOTAL AREA

Plug Power - Proposed Conditions 5-15-21

Prepared by {enter your company name here}

HydroCAD® 10.10-5a s/n 11585 © 2020 HydroCAD Software Solutions LLC

Printed 5/20/2021

Page 5

Soil Listing (all nodes)

Area (acres)	Soil Group	Subcatchment Numbers
0.000	HSG A	
0.000	HSG B	
0.000	HSG C	
29.096	HSG D	1S, 2S, 3S, 4S, 8S, 10S, 12S, 14S, 18S, 20S, 24S, 26S, 29S, 30S, 32S, 36S, 38S, 40S, 42S, 43S, 45S, 48S, 49S, 52S, 53S, 54S, 55S, 56S, 57S, 58S
0.000	Other	
29.096		TOTAL AREA

Plug Power - Proposed Conditions 5-15-21

Prepared by {enter your company name here}

Printed 5/20/2021

HydroCAD® 10.10-5a s/n 11585 © 2020 HydroCAD Software Solutions LLC

Page 6

Ground Covers (all nodes)

HSG-A (acres)	HSG-B (acres)	HSG-C (acres)	HSG-D (acres)	Other (acres)	Total (acres)	Ground Cover	Subcatchment Numbers
0.000	0.000	0.000	9.685	0.000	9.685	>75% Grass cover, Good	1S, 3S, 10S, 12S, 14S, 18S, 20S, 24S, 26S, 30S, 32S, 36S, 38S, 42S, 48S, 49S, 52S, 53S, 54S, 55S, 56S
0.000	0.000	0.000	2.105	0.000	2.105	Brush, Fair	8S, 57S, 58S
0.000	0.000	0.000	3.004	0.000	3.004	Gravel Storage Area, Good	20S, 42S
0.000	0.000	0.000	0.667	0.000	0.667	Meadow, non-grazed	1S, 3S, 38S
0.000	0.000	0.000	5.945	0.000	5.945	Paved parking	10S, 12S, 14S, 20S, 24S, 26S, 32S, 36S, 38S, 40S, 42S, 48S, 49S

Plug Power - Proposed Conditions 5-15-21

Prepared by {enter your company name here}

Printed 5/20/2021

HydroCAD® 10.10-5a s/n 11585 © 2020 HydroCAD Software Solutions LLC

Page 7

Ground Covers (all nodes) (continued)

HSG-A (acres)	HSG-B (acres)	HSG-C (acres)	HSG-D (acres)	Other (acres)	Total (acres)	Ground Cover	Subcatchment Numbers
0.000	0.000	0.000	5.115	0.000	5.115	Roofs	10S, 12S, 20S, 24S, 26S, 29S, 42S, 43S, 45S, 48S, 49S
0.000	0.000	0.000	1.449	0.000	1.449	Unconnected pavement	18S, 20S, 30S, 36S, 42S
0.000	0.000	0.000	0.610	0.000	0.610	Woods, Fair	1S, 38S
0.000	0.000	0.000	0.516	0.000	0.516	Woods/grass comb., Good	2S, 4S
0.000	0.000	0.000	29.096	0.000	29.096	TOTAL AREA	

Plug Power - Proposed Conditions 5-15-21

Prepared by {enter your company name here}

HydroCAD® 10.10-5a s/n 11585 © 2020 HydroCAD Software Solutions LLC

Printed 5/20/2021

Page 8

Pipe Listing (all nodes)

Line#	Node Number	In-Invert (feet)	Out-Invert (feet)	Length (feet)	Slope (ft/ft)	n	Width (inches)	Diam/Height (inches)	Inside-Fill (inches)
1	11P	667.41	667.14	137.0	0.0020	0.012	0.0	12.0	0.0
2	13P	667.14	666.71	213.0	0.0020	0.012	0.0	12.0	0.0
3	15P	666.71	666.35	180.0	0.0020	0.012	0.0	24.0	0.0
4	19P	665.26	665.12	70.0	0.0020	0.012	0.0	10.0	0.0
5	21P	664.01	663.90	57.0	0.0019	0.012	0.0	18.0	0.0
6	21P	664.01	663.90	57.0	0.0019	0.012	0.0	18.0	0.0
7	21P	665.95	665.85	50.0	0.0020	0.012	0.0	18.0	0.0
8	22P	660.55	660.50	25.0	0.0020	0.012	0.0	15.0	0.0
9	22P	660.55	660.50	25.0	0.0020	0.012	0.0	15.0	0.0
10	22P	660.56	660.55	5.0	0.0020	0.012	0.0	4.0	0.0
11	22P	660.56	660.55	5.0	0.0020	0.012	0.0	4.0	0.0
12	25P	666.25	665.91	170.0	0.0020	0.012	0.0	12.0	0.0
13	27P	665.99	665.91	40.0	0.0020	0.012	0.0	12.0	0.0
14	28P	665.91	665.60	157.0	0.0020	0.012	0.0	18.0	0.0
15	29P	662.56	662.50	30.0	0.0020	0.012	0.0	12.0	0.0
16	29P	662.56	662.50	30.0	0.0020	0.012	0.0	12.0	0.0
17	31P	665.60	665.43	83.0	0.0020	0.012	0.0	18.0	0.0
18	33P	665.42	665.07	175.0	0.0020	0.012	0.0	12.0	0.0
19	37P	665.07	664.64	214.0	0.0020	0.012	0.0	15.0	0.0
20	39P	664.64	664.34	150.0	0.0020	0.012	0.0	18.0	0.0
21	41P	664.34	664.01	166.0	0.0020	0.012	0.0	24.0	0.0
22	44P	665.12	664.91	105.0	0.0020	0.012	0.0	24.0	0.0
23	46P	665.43	665.12	157.0	0.0020	0.012	0.0	24.0	0.0
24	50P	666.95	666.71	122.0	0.0020	0.012	0.0	18.0	0.0
25	51P	667.23	666.95	138.0	0.0020	0.012	0.0	15.0	0.0

Plug Power - Proposed Conditions 5-15-21

Type II 24-hr 1-yr Rainfall=1.82"

Prepared by {enter your company name here}

Printed 5/20/2021

HydroCAD® 10.10-5a s/n 11585 © 2020 HydroCAD Software Solutions LLC

Page 9

Time span=0.00-48.00 hrs, dt=0.15 hrs, 321 points
Runoff by SCS TR-20 method, UH=SCS, Weighted-CN
Reach routing by Dyn-Stor-Ind method - Pond routing by Dyn-Stor-Ind method

Subcatchment 1S: Prop. Area to SW Runoff Area=25,495 sf 0.00% Impervious Runoff Depth=0.42"
Flow Length=90' Slope=0.0200 '/' Tc=20.5 min CN=79 Runoff=0.22 cfs 0.021 af

Subcatchment 2S: Prop. Area to SE Runoff Area=12,470 sf 0.00% Impervious Runoff Depth=0.42"
Flow Length=100' Slope=0.0150 '/' Tc=19.6 min CN=79 Runoff=0.11 cfs 0.010 af

Subcatchment 3S: Prop. Area to West Runoff Area=38,190 sf 0.00% Impervious Runoff Depth=0.42"
Flow Length=350' Tc=18.2 min CN=79 Runoff=0.35 cfs 0.031 af

Subcatchment 4S: Prop. Area to Crosby Runoff Area=10,015 sf 0.00% Impervious Runoff Depth=0.42"
Flow Length=125' Slope=0.0100 '/' Tc=23.3 min CN=79 Runoff=0.08 cfs 0.008 af

Subcatchment 8S: Area Overland to North Runoff Area=51,085 sf 0.00% Impervious Runoff Depth=0.36"
Flow Length=140' Tc=11.7 min CN=77 Runoff=0.42 cfs 0.035 af

Subcatchment 10S: Area to CB#1 Runoff Area=19,240 sf 67.06% Impervious Runoff Depth=1.08"
Flow Length=80' Tc=12.8 min CN=92 Runoff=0.58 cfs 0.040 af

Subcatchment 12S: Area to CB#2 Runoff Area=12,315 sf 47.61% Impervious Runoff Depth=0.88"
Flow Length=80' Tc=12.8 min CN=89 Runoff=0.30 cfs 0.021 af

Subcatchment 14S: Area to CB#3 Runoff Area=18,345 sf 46.99% Impervious Runoff Depth=0.82"
Flow Length=260' Tc=19.1 min CN=88 Runoff=0.37 cfs 0.029 af

Subcatchment 18S: Area to YD#2 Runoff Area=27,200 sf 27.67% Impervious Runoff Depth=0.53"
Flow Length=140' Slope=0.0100 '/' Tc=23.4 min UI Adjusted CN=82 Runoff=0.30 cfs 0.028 af

Subcatchment 20S: Eastern Area Runoff Area=329,310 sf 62.48% Impervious Runoff Depth=1.01"
Flow Length=330' Tc=30.2 min CN=91 Runoff=6.34 cfs 0.635 af

Subcatchment 24S: Area to YD#11 Runoff Area=38,900 sf 53.89% Impervious Runoff Depth=0.94"
Flow Length=70' Slope=0.0100 '/' Tc=17.3 min CN=90 Runoff=0.92 cfs 0.070 af

Subcatchment 26S: Area to CB#4 Runoff Area=41,205 sf 62.20% Impervious Runoff Depth=1.01"
Flow Length=100' Tc=16.9 min CN=91 Runoff=1.05 cfs 0.079 af

Subcatchment 29S: Area to CB#15 Runoff Area=17,040 sf 100.00% Impervious Runoff Depth=1.60"
Tc=5.0 min CN=98 Runoff=0.80 cfs 0.052 af

Subcatchment 30S: Area to CB#18 Runoff Area=20,100 sf 15.05% Impervious Runoff Depth=0.49"
Flow Length=140' Slope=0.0100 '/' Tc=23.4 min UI Adjusted CN=81 Runoff=0.20 cfs 0.019 af

Subcatchment 32S: Area to CB#7 Runoff Area=36,220 sf 69.35% Impervious Runoff Depth=1.08"
Flow Length=100' Tc=16.9 min CN=92 Runoff=0.98 cfs 0.075 af

Subcatchment 36S: Area to CB#9 Runoff Area=18,475 sf 44.79% Impervious Runoff Depth=0.82"
Flow Length=80' Slope=0.0100 '/' Tc=19.3 min CN=88 Runoff=0.37 cfs 0.029 af

Plug Power - Proposed Conditions 5-15-21

Type II 24-hr 1-yr Rainfall=1.82"

Prepared by {enter your company name here}

Printed 5/20/2021

HydroCAD® 10.10-5a s/n 11585 © 2020 HydroCAD Software Solutions LLC

Page 10

Subcatchment 38S: Area to CB#10	Runoff Area=39,650 sf 16.97% Impervious	Runoff Depth=0.58"
Flow Length=150'	Slope=0.0140 '/' Tc=20.6 min CN=83	Runoff=0.52 cfs 0.044 af
Subcatchment 40S: Area to CB#11	Runoff Area=31,495 sf 100.00% Impervious	Runoff Depth=1.60"
Flow Length=170'	Slope=0.0120 '/' Tc=22.1 min CN=98	Runoff=1.09 cfs 0.096 af
Subcatchment 42S: Western Area	Runoff Area=139,665 sf 42.71% Impervious	Runoff Depth=0.82"
Flow Length=50'	Slope=0.0200 '/' Tc=6.3 min CN=88	Runoff=3.93 cfs 0.220 af
Subcatchment 43S: North Half of Phase 2	Runoff Area=36,505 sf 100.00% Impervious	Runoff Depth=1.60"
	Tc=5.0 min CN=98	Runoff=1.70 cfs 0.111 af
Subcatchment 45S: South Half of Phase	Runoff Area=32,290 sf 100.00% Impervious	Runoff Depth=1.60"
	Tc=5.0 min CN=98	Runoff=1.51 cfs 0.099 af
Subcatchment 48S: Area to YD#1	Runoff Area=34,030 sf 37.80% Impervious	Runoff Depth=0.77"
Flow Length=150'	Slope=0.0100 '/' Tc=23.6 min CN=87	Runoff=0.57 cfs 0.050 af
Subcatchment 49S: Area to YD#3	Runoff Area=81,835 sf 30.11% Impervious	Runoff Depth=0.67"
Flow Length=340'	Tc=25.3 min CN=85	Runoff=1.12 cfs 0.104 af
Subcatchment 52S: Area Overland to	Runoff Area=71,325 sf 0.00% Impervious	Runoff Depth=0.46"
	Flow Length=30' Tc=5.4 min CN=80	Runoff=1.06 cfs 0.062 af
Subcatchment 53S: Area Overland to	Runoff Area=5,925 sf 0.00% Impervious	Runoff Depth=0.46"
	Tc=5.0 min CN=80	Runoff=0.09 cfs 0.005 af
Subcatchment 54S: Area Overland to	Runoff Area=6,040 sf 0.00% Impervious	Runoff Depth=0.46"
	Tc=5.0 min CN=80	Runoff=0.09 cfs 0.005 af
Subcatchment 55S: Area Overland to	Runoff Area=13,210 sf 0.00% Impervious	Runoff Depth=0.46"
Flow Length=25'	Slope=0.0100 '/' Tc=7.6 min CN=80	Runoff=0.19 cfs 0.012 af
Subcatchment 56S: Area Overland to Dry	Runoff Area=19,245 sf 0.00% Impervious	Runoff Depth=0.46"
	Tc=5.0 min CN=80	Runoff=0.28 cfs 0.017 af
Subcatchment 57S: Area Overland to North	Runoff Area=23,585 sf 0.00% Impervious	Runoff Depth=0.36"
	Flow Length=100' Tc=10.8 min CN=77	Runoff=0.21 cfs 0.016 af
Subcatchment 58S: Area Overland to North	Runoff Area=17,005 sf 0.00% Impervious	Runoff Depth=0.36"
	Flow Length=170' Tc=14.9 min CN=77	Runoff=0.13 cfs 0.012 af
Reach 7R: Crosby Road Ditch	Avg. Flow Depth=0.05' Max Vel=0.58 fps	Inflow=0.08 cfs 0.008 af
n=0.030 L=450.0' S=0.0089 '/'	Capacity=98.41 cfs	Outflow=0.06 cfs 0.008 af
Reach 9R: North Property Line Ditch	Avg. Flow Depth=0.11' Max Vel=0.91 fps	Inflow=0.44 cfs 0.043 af
n=0.030 L=670.0' S=0.0100 '/'	Capacity=634.40 cfs	Outflow=0.30 cfs 0.043 af
Reach 23R: North Swale to	Avg. Flow Depth=1.64' Max Vel=0.35 fps	Inflow=6.61 cfs 0.778 af
n=0.300 L=180.0' S=0.0050 '/'	Capacity=23.67 cfs	Outflow=6.02 cfs 0.778 af

Plug Power - Proposed Conditions 5-15-21

Type II 24-hr 1-yr Rainfall=1.82"

Prepared by {enter your company name here}

Printed 5/20/2021

HydroCAD® 10.10-5a s/n 11585 © 2020 HydroCAD Software Solutions LLC

Page 11

Reach 25R: North Property Line Ditch Avg. Flow Depth=0.17' Max Vel=0.75 fps Inflow=0.57 cfs 0.087 af
 n=0.030 L=500.0' S=0.0040 ' ' Capacity=401.23 cfs Outflow=0.48 cfs 0.087 af

Reach 26R: North Property Line Ditch Avg. Flow Depth=0.36' Max Vel=0.88 fps Inflow=1.88 cfs 1.972 af
 n=0.030 L=500.0' S=0.0024 ' ' Capacity=310.79 cfs Outflow=1.75 cfs 1.972 af

Reach 27R: Swale to Dry Pond Avg. Flow Depth=0.07' Max Vel=0.52 fps Inflow=0.19 cfs 0.012 af
 x 2.00 n=0.030 L=130.0' S=0.0050 ' ' Capacity=118.87 cfs Outflow=0.15 cfs 0.012 af

Reach 52R: West Swale to Avg. Flow Depth=1.88' Max Vel=0.37 fps Inflow=9.25 cfs 1.032 af
 n=0.300 L=180.0' S=0.0050 ' ' Capacity=23.67 cfs Outflow=8.10 cfs 1.032 af

Pond 11P: CB#1 Peak Elev=667.97' Inflow=0.58 cfs 0.040 af
 12.0" Round Culvert n=0.012 L=137.0' S=0.0020 ' ' Outflow=0.58 cfs 0.040 af

Pond 13P: CB#3 Peak Elev=667.81' Inflow=0.88 cfs 0.060 af
 12.0" Round Culvert n=0.012 L=213.0' S=0.0020 ' ' Outflow=0.88 cfs 0.060 af

Pond 15P: CB#5 Peak Elev=667.60' Inflow=2.68 cfs 0.243 af
 24.0" Round Culvert n=0.012 L=180.0' S=0.0020 ' ' Outflow=2.68 cfs 0.243 af

Pond 19P: YD#22 Peak Elev=666.46' Storage=1 cf Inflow=0.30 cfs 0.028 af
 10.0" Round Culvert n=0.012 L=70.0' S=0.0020 ' ' Outflow=0.30 cfs 0.028 af

Pond 21P: Subsurface Detention within Peak Elev=665.90' Storage=3,785 cf Inflow=17.37 cfs 1.800 af
 Primary=9.17 cfs 1.027 af Secondary=6.59 cfs 0.773 af Tertiary=0.00 cfs 0.000 af Outflow=14.47 cfs 1.800 af

Pond 22P: Bio-Retention Area Peak Elev=663.82' Storage=42,072 cf Inflow=13.85 cfs 1.873 af
 Primary=1.48 cfs 1.873 af Secondary=0.00 cfs 0.000 af Outflow=1.48 cfs 1.873 af

Pond 25P: YD#11 Peak Elev=667.10' Storage=1 cf Inflow=0.92 cfs 0.070 af
 12.0" Round Culvert n=0.012 L=170.0' S=0.0020 ' ' Outflow=0.92 cfs 0.070 af

Pond 27P: CB#4 Peak Elev=666.96' Storage=4 cf Inflow=1.05 cfs 0.079 af
 12.0" Round Culvert n=0.012 L=40.0' S=0.0020 ' ' Outflow=1.04 cfs 0.079 af

Pond 28P: CB#15 Peak Elev=666.94' Storage=4 cf Inflow=2.45 cfs 0.202 af
 18.0" Round Culvert n=0.012 L=157.0' S=0.0020 ' ' Outflow=2.45 cfs 0.202 af

Pond 29P: Dry Pond Peak Elev=662.76' Storage=321 cf Inflow=0.43 cfs 0.028 af
 Primary=0.13 cfs 0.028 af Tertiary=0.00 cfs 0.000 af Outflow=0.13 cfs 0.028 af

Pond 31P: CB#18 Peak Elev=666.80' Storage=5 cf Inflow=2.57 cfs 0.221 af
 18.0" Round Culvert n=0.012 L=83.0' S=0.0020 ' ' Outflow=2.57 cfs 0.221 af

Pond 33P: CB#26 Peak Elev=666.15' Storage=3 cf Inflow=0.98 cfs 0.075 af
 12.0" Round Culvert n=0.012 L=175.0' S=0.0020 ' ' Outflow=0.98 cfs 0.075 af

Pond 37P: CB#28 Peak Elev=665.93' Storage=3 cf Inflow=1.35 cfs 0.104 af
 15.0" Round Culvert n=0.012 L=214.0' S=0.0020 ' ' Outflow=1.35 cfs 0.104 af

Plug Power - Proposed Conditions 5-15-21

Type II 24-hr 1-yr Rainfall=1.82"

Prepared by {enter your company name here}

Printed 5/20/2021

HydroCAD® 10.10-5a s/n 11585 © 2020 HydroCAD Software Solutions LLC

Page 12

Pond 39P: CB#30 Peak Elev=665.92' Storage=5 cf Inflow=1.85 cfs 0.147 af
18.0" Round Culvert n=0.012 L=150.0' S=0.0020 '/ Outflow=1.85 cfs 0.147 af

Pond 41P: CB#32 Peak Elev=665.91' Storage=6 cf Inflow=2.94 cfs 0.243 af
24.0" Round Culvert n=0.012 L=166.0' S=0.0020 '/ Outflow=2.93 cfs 0.243 af

Pond 44P: CB#24 Peak Elev=666.45' Inflow=5.69 cfs 0.458 af
24.0" Round Culvert n=0.012 L=105.0' S=0.0020 '/ Outflow=5.69 cfs 0.458 af

Pond 46P: CB#20 Peak Elev=666.67' Inflow=3.91 cfs 0.319 af
24.0" Round Culvert n=0.012 L=157.0' S=0.0020 '/ Outflow=3.91 cfs 0.319 af

Pond 50P: YD#8 Peak Elev=667.83' Storage=1 cf Inflow=1.69 cfs 0.154 af
18.0" Round Culvert n=0.012 L=122.0' S=0.0020 '/ Outflow=1.69 cfs 0.154 af

Pond 51P: YD#6 Peak Elev=668.01' Storage=1 cf Inflow=1.12 cfs 0.104 af
15.0" Round Culvert n=0.012 L=138.0' S=0.0020 '/ Outflow=1.12 cfs 0.104 af

Link 52L: Total Site Discharge Inflow=1.87 cfs 2.033 af
Primary=1.87 cfs 2.033 af

Total Runoff Area = 29.096 ac Runoff Volume = 2.033 af Average Runoff Depth = 0.84"
57.01% Pervious = 16.587 ac 42.99% Impervious = 12.509 ac

Plug Power - Proposed Conditions 5-15-21

Type II 24-hr 1-yr Rainfall=1.82"

Prepared by {enter your company name here}

Printed 5/20/2021

HydroCAD® 10.10-5a s/n 11585 © 2020 HydroCAD Software Solutions LLC

Page 13

Summary for Subcatchment 1S: Prop. Area to SW Property Line (Wetland)

Runoff = 0.22 cfs @ 12.17 hrs, Volume= 0.021 af, Depth= 0.42"

Runoff by SCS TR-20 method, UH=SCS, Weighted-CN, Time Span= 0.00-48.00 hrs, dt= 0.15 hrs
Type II 24-hr 1-yr Rainfall=1.82"

Area (sf)	CN	Description
5,020	78	Meadow, non-grazed, HSG D
18,430	79	Woods, Fair, HSG D
2,045	80	>75% Grass cover, Good, HSG D
25,495	79	Weighted Average
25,495		100.00% Pervious Area

Tc (min)	Length (feet)	Slope (ft/ft)	Velocity (ft/sec)	Capacity (cfs)	Description
2.8	10	0.0200	0.06		Sheet Flow, 10' Overland Flow Grass: Dense n= 0.240 P2= 2.14"
5.1	40	0.0200	0.13		Sheet Flow, 40' Overland Flow Range n= 0.130 P2= 2.14"
12.6	40	0.0200	0.05		Sheet Flow, 40' Overland Flow Woods: Light underbrush n= 0.400 P2= 2.14"
20.5	90	Total			

Subcatchment 1S: Prop. Area to SW Property Line (Wetland)

Hydrograph

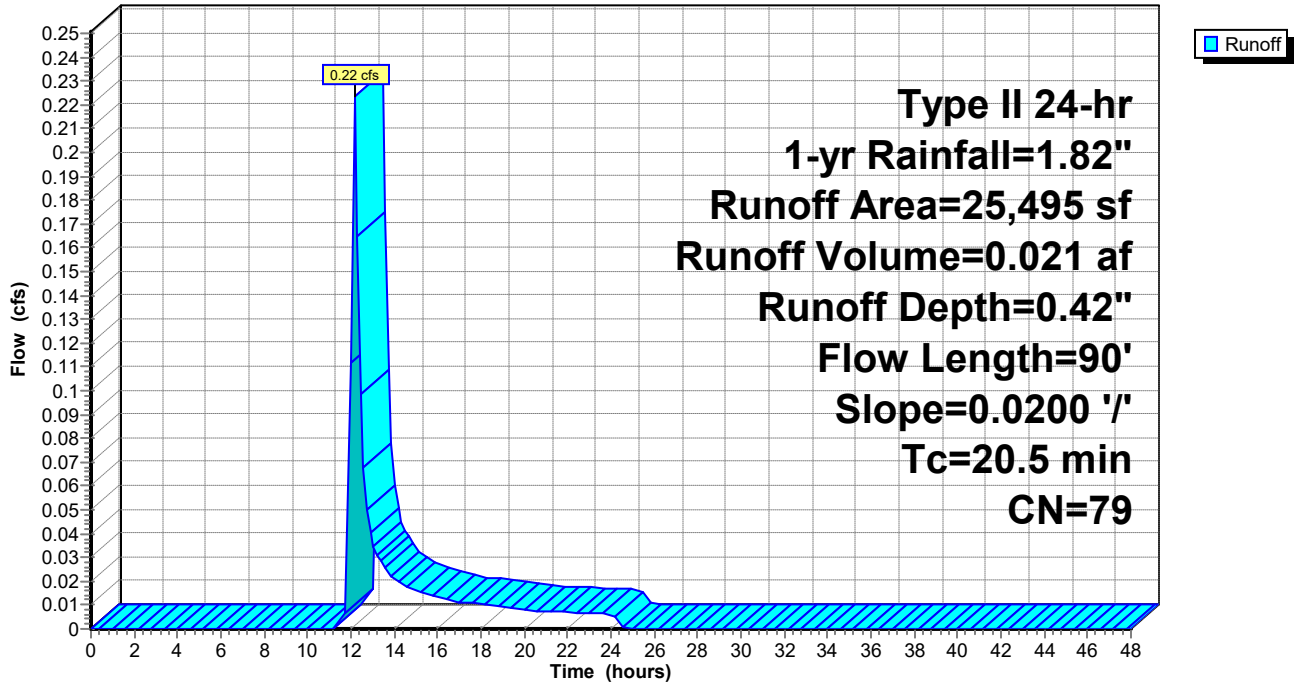

Plug Power - Proposed Conditions 5-15-21

Prepared by {enter your company name here}

HydroCAD® 10.10-5a s/n 11585 © 2020 HydroCAD Software Solutions LLC

Type II 24-hr 1-yr Rainfall=1.82"

Printed 5/20/2021

Page 14

Summary for Subcatchment 2S: Prop. Area to SE Property Line

Runoff = 0.11 cfs @ 12.17 hrs, Volume= 0.010 af, Depth= 0.42"

Runoff by SCS TR-20 method, UH=SCS, Weighted-CN, Time Span= 0.00-48.00 hrs, dt= 0.15 hrs
Type II 24-hr 1-yr Rainfall=1.82"

Area (sf)	CN	Description
12,470	79	Woods/grass comb., Good, HSG D
12,470		100.00% Pervious Area

Tc (min)	Length (feet)	Slope (ft/ft)	Velocity (ft/sec)	Capacity (cfs)	Description
19.6	100	0.0150	0.09		Sheet Flow, 100' Overland Flow Grass: Dense n= 0.240 P2= 2.14"

Subcatchment 2S: Prop. Area to SE Property Line

Hydrograph

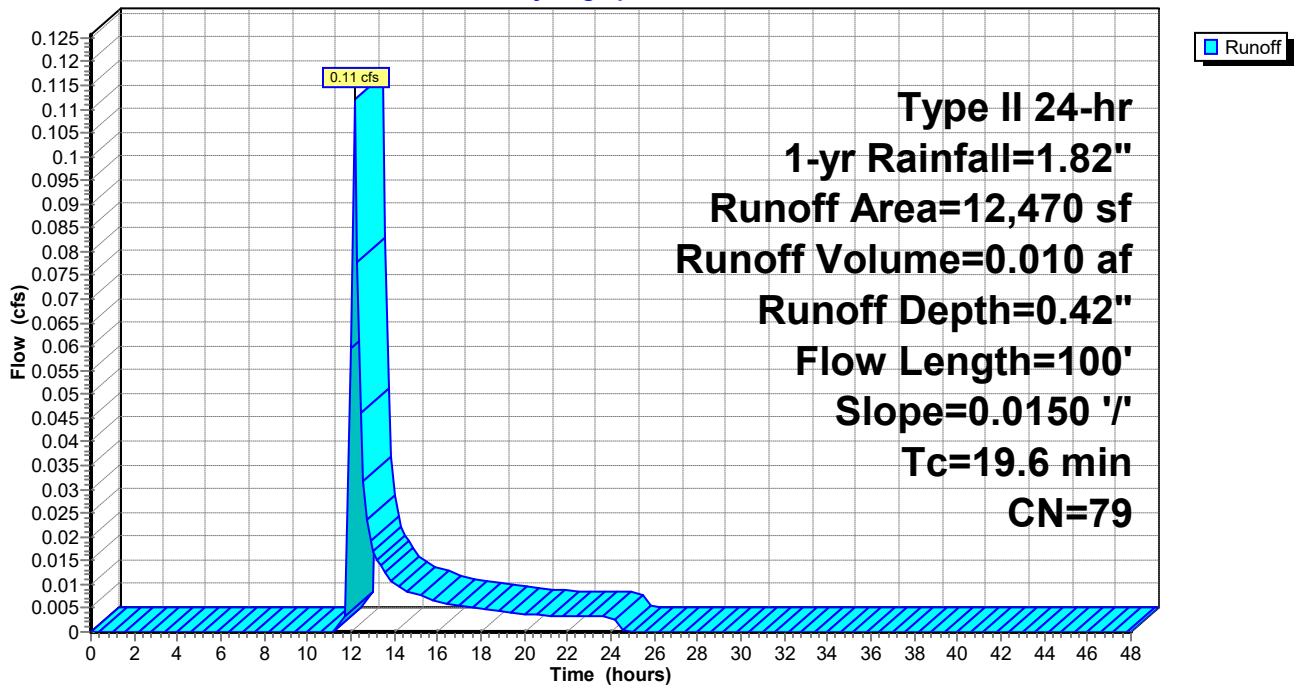

Plug Power - Proposed Conditions 5-15-21

Type II 24-hr 1-yr Rainfall=1.82"

Prepared by {enter your company name here}

Printed 5/20/2021

HydroCAD® 10.10-5a s/n 11585 © 2020 HydroCAD Software Solutions LLC

Page 15

Summary for Subcatchment 3S: Prop. Area to West Property Line (Wetland)

Runoff = 0.35 cfs @ 12.15 hrs, Volume= 0.031 af, Depth= 0.42"

Runoff by SCS TR-20 method, UH=SCS, Weighted-CN, Time Span= 0.00-48.00 hrs, dt= 0.15 hrs
Type II 24-hr 1-yr Rainfall=1.82"

Area (sf)	CN	Description
20,080	80	>75% Grass cover, Good, HSG D
18,110	78	Meadow, non-grazed, HSG D
38,190	79	Weighted Average
38,190		100.00% Pervious Area

Tc (min)	Length (feet)	Slope (ft/ft)	Velocity (ft/sec)	Capacity (cfs)	Description
16.0	100	0.0250	0.10		Sheet Flow, 100' Overland Flow Grass: Dense n= 0.240 P2= 2.14"
2.2	250	0.0160	1.90		Shallow Concentrated Flow, 250' Shallow Conc. Flow Grassed Waterway Kv= 15.0 fps
18.2	350	Total			

Subcatchment 3S: Prop. Area to West Property Line (Wetland)

Hydrograph

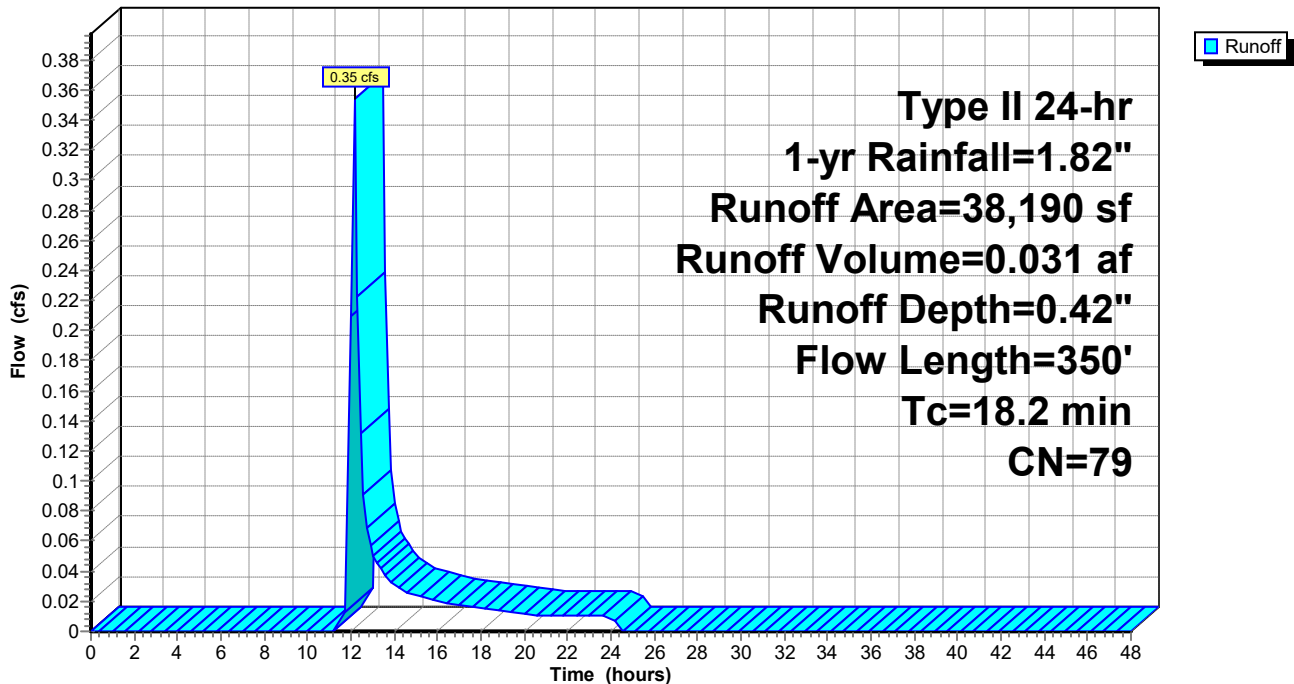

Plug Power - Proposed Conditions 5-15-21

Type II 24-hr 1-yr Rainfall=1.82"

Prepared by {enter your company name here}

Printed 5/20/2021

HydroCAD® 10.10-5a s/n 11585 © 2020 HydroCAD Software Solutions LLC

Page 16

Summary for Subcatchment 4S: Prop. Area to Crosby Road Ditch

Runoff = 0.08 cfs @ 12.20 hrs, Volume= 0.008 af, Depth= 0.42"

Runoff by SCS TR-20 method, UH=SCS, Weighted-CN, Time Span= 0.00-48.00 hrs, dt= 0.15 hrs
Type II 24-hr 1-yr Rainfall=1.82"

Area (sf)	CN	Description
10,015	79	Woods/grass comb., Good, HSG D
10,015		100.00% Pervious Area

Tc (min)	Length (feet)	Slope (ft/ft)	Velocity (ft/sec)	Capacity (cfs)	Description
23.0	100	0.0100	0.07		Sheet Flow, 100' Overland Flow Grass: Dense n= 0.240 P2= 2.14"
0.3	25	0.0100	1.50		Shallow Concentrated Flow, 25' Shallow Conc. Flow Grassed Waterway Kv= 15.0 fps
23.3	125	Total			

Subcatchment 4S: Prop. Area to Crosby Road Ditch

Hydrograph

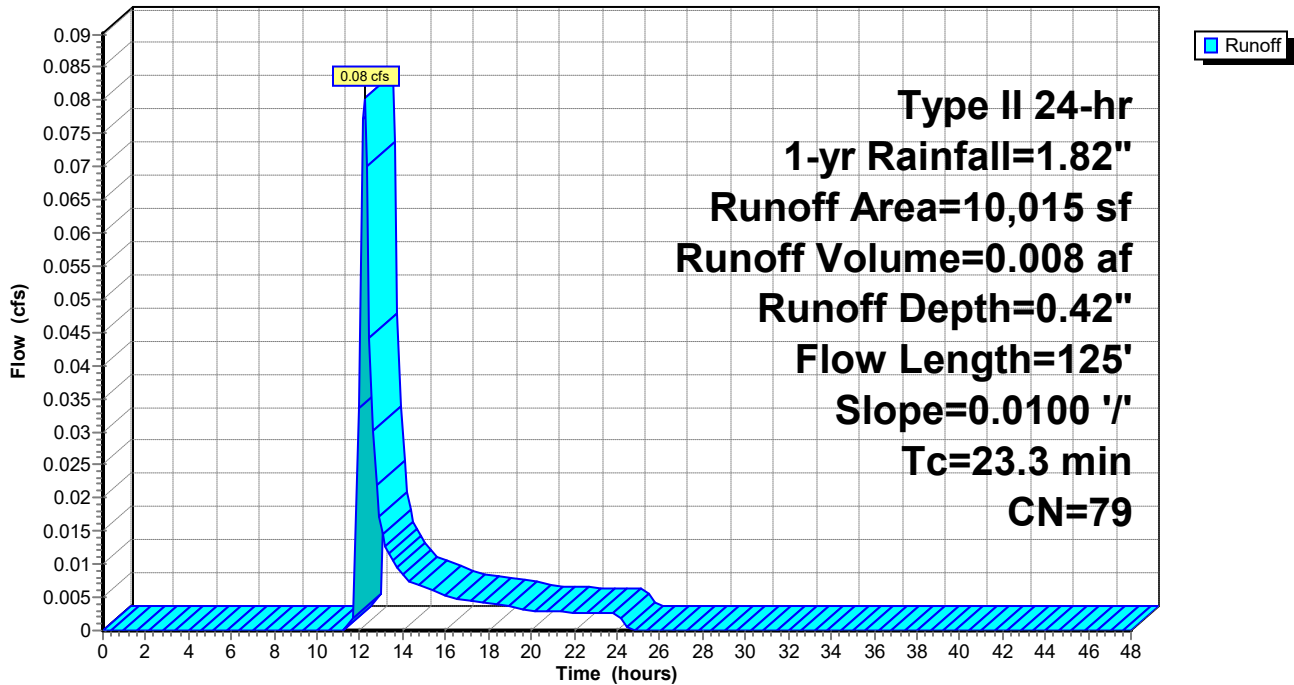

Plug Power - Proposed Conditions 5-15-21

Prepared by {enter your company name here}

HydroCAD® 10.10-5a s/n 11585 © 2020 HydroCAD Software Solutions LLC

Type II 24-hr 1-yr Rainfall=1.82"

Printed 5/20/2021

Page 17

Summary for Subcatchment 8S: Area Overland to North Prop. Line and Wetland Ditch (East)

Runoff = 0.42 cfs @ 12.06 hrs, Volume= 0.035 af, Depth= 0.36"

Runoff by SCS TR-20 method, UH=SCS, Weighted-CN, Time Span= 0.00-48.00 hrs, dt= 0.15 hrs
 Type II 24-hr 1-yr Rainfall=1.82"

Area (sf)	CN	Description
51,085	77	Brush, Fair, HSG D
51,085		100.00% Pervious Area

Tc (min)	Length (feet)	Slope (ft/ft)	Velocity (ft/sec)	Capacity (cfs)	Description
10.7	100	0.0200	0.16		Sheet Flow, 100' Overland Flow Range n= 0.130 P2= 2.14"
1.0	40	0.0100	0.70		Shallow Concentrated Flow, 40' Shallow Conc. Flow Short Grass Pasture Kv= 7.0 fps
11.7	140	Total			

Subcatchment 8S: Area Overland to North Prop. Line and Wetland Ditch (East)

Hydrograph

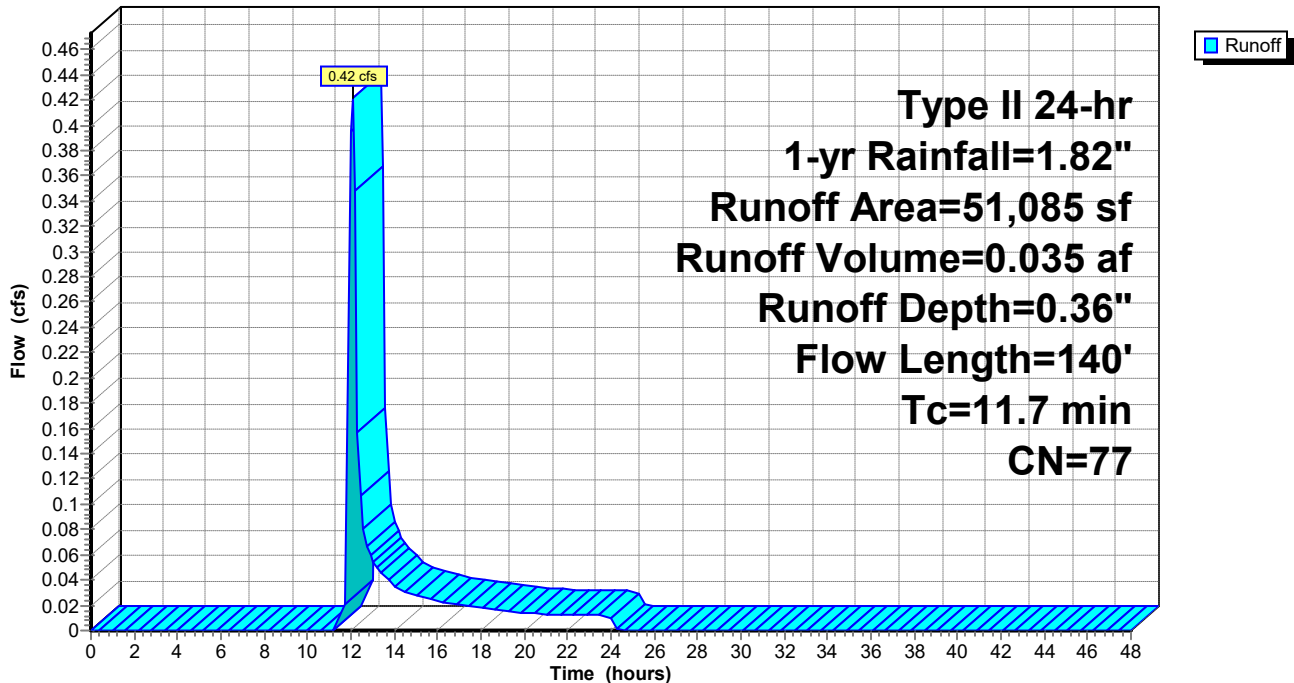

Plug Power - Proposed Conditions 5-15-21

Type II 24-hr 1-yr Rainfall=1.82"

Prepared by {enter your company name here}

Printed 5/20/2021

HydroCAD® 10.10-5a s/n 11585 © 2020 HydroCAD Software Solutions LLC

Page 18

Summary for Subcatchment 10S: Area to CB#1

Runoff = 0.58 cfs @ 12.03 hrs, Volume= 0.040 af, Depth= 1.08"

Runoff by SCS TR-20 method, UH=SCS, Weighted-CN, Time Span= 0.00-48.00 hrs, dt= 0.15 hrs
Type II 24-hr 1-yr Rainfall=1.82"

Area (sf)	CN	Description
4,063	98	Roofs, HSG D
8,840	98	Paved parking, HSG D
6,337	80	>75% Grass cover, Good, HSG D
19,240	92	Weighted Average
6,337		32.94% Pervious Area
12,903		67.06% Impervious Area

Tc (min)	Length (feet)	Slope (ft/ft)	Velocity (ft/sec)	Capacity (cfs)	Description
12.4	65	0.0200	0.09		Sheet Flow, 65' Overland Flow
					Grass: Dense n= 0.240 P2= 2.14"
0.4	15	0.0100	0.58		Sheet Flow, 15' Overland Flow
					Smooth surfaces n= 0.011 P2= 2.14"
12.8	80	Total			

Subcatchment 10S: Area to CB#1

Hydrograph

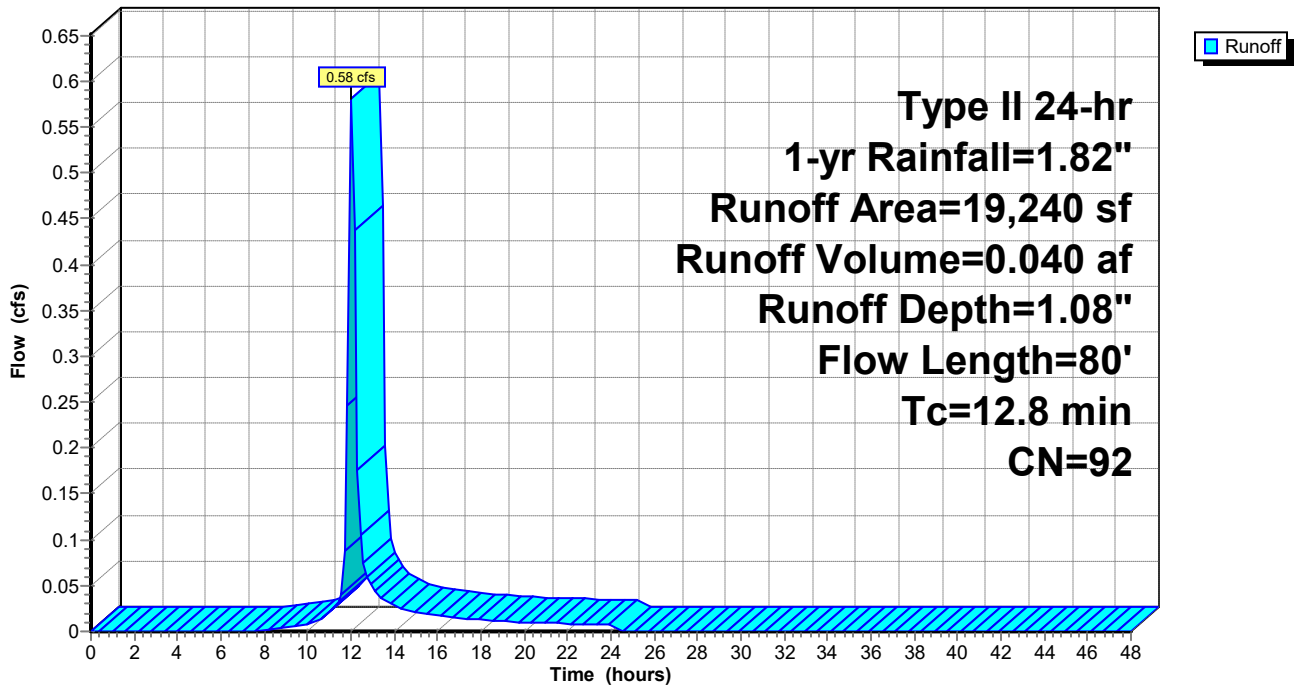

Plug Power - Proposed Conditions 5-15-21

Type II 24-hr 1-yr Rainfall=1.82"

Prepared by {enter your company name here}

Printed 5/20/2021

HydroCAD® 10.10-5a s/n 11585 © 2020 HydroCAD Software Solutions LLC

Page 19

Summary for Subcatchment 12S: Area to CB#2

Runoff = 0.30 cfs @ 12.04 hrs, Volume= 0.021 af, Depth= 0.88"

Runoff by SCS TR-20 method, UH=SCS, Weighted-CN, Time Span= 0.00-48.00 hrs, dt= 0.15 hrs
Type II 24-hr 1-yr Rainfall=1.82"

Area (sf)	CN	Description
4,063	98	Roofs, HSG D
1,800	98	Paved parking, HSG D
6,452	80	>75% Grass cover, Good, HSG D
12,315	89	Weighted Average
6,452		52.39% Pervious Area
5,863		47.61% Impervious Area

Tc (min)	Length (feet)	Slope (ft/ft)	Velocity (ft/sec)	Capacity (cfs)	Description
12.4	65	0.0200	0.09		Sheet Flow, 65' Overland Flow
					Grass: Dense n= 0.240 P2= 2.14"
0.4	15	0.0100	0.58		Sheet Flow, 15' Overland Flow
					Smooth surfaces n= 0.011 P2= 2.14"
12.8	80	Total			

Subcatchment 12S: Area to CB#2

Hydrograph

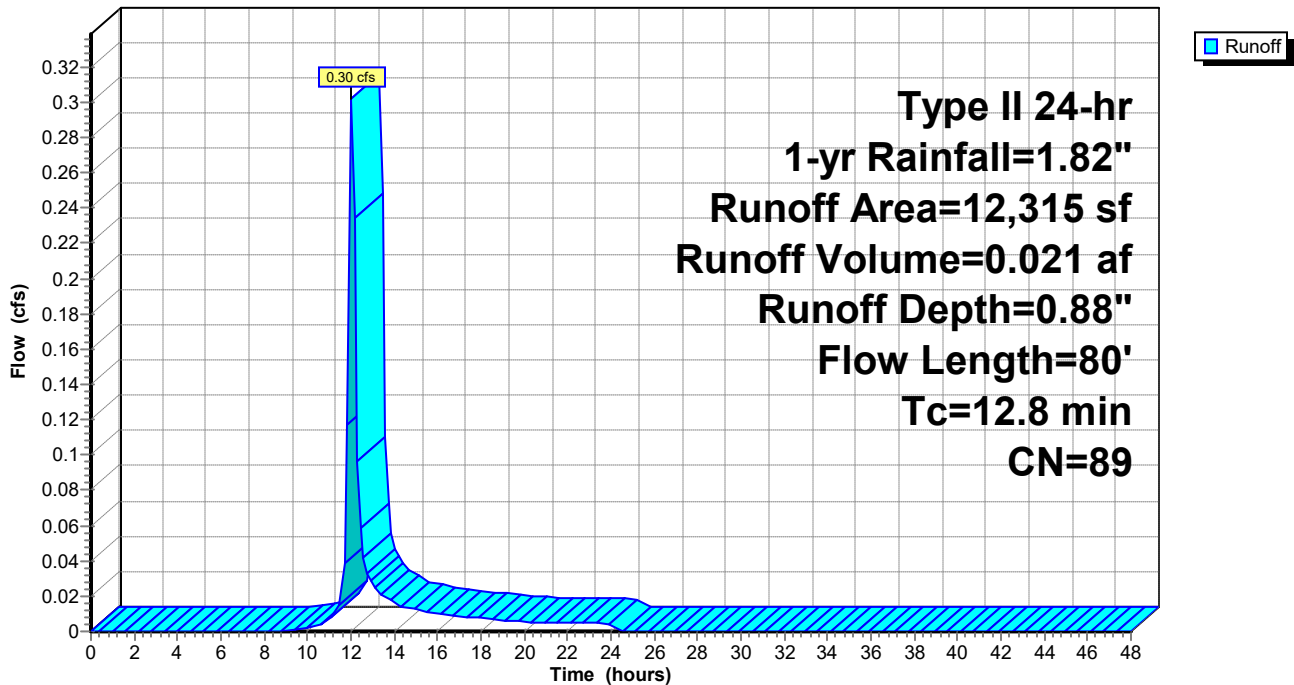

Plug Power - Proposed Conditions 5-15-21

Type II 24-hr 1-yr Rainfall=1.82"

Prepared by {enter your company name here}

Printed 5/20/2021

HydroCAD® 10.10-5a s/n 11585 © 2020 HydroCAD Software Solutions LLC

Page 20

Summary for Subcatchment 14S: Area to CB#3

Runoff = 0.37 cfs @ 12.14 hrs, Volume= 0.029 af, Depth= 0.82"

Runoff by SCS TR-20 method, UH=SCS, Weighted-CN, Time Span= 0.00-48.00 hrs, dt= 0.15 hrs
Type II 24-hr 1-yr Rainfall=1.82"

Area (sf)	CN	Description
8,620	98	Paved parking, HSG D
9,725	80	>75% Grass cover, Good, HSG D
18,345	88	Weighted Average
9,725		53.01% Pervious Area
8,620		46.99% Impervious Area

Tc (min)	Length (feet)	Slope (ft/ft)	Velocity (ft/sec)	Capacity (cfs)	Description
17.5	100	0.0200	0.10		Sheet Flow, 100' Overland Flow Grass: Dense n= 0.240 P2= 2.14"
1.4	130	0.0100	1.50		Shallow Concentrated Flow, 130' Shallow Conc. Flow Grassed Waterway Kv= 15.0 fps
0.2	30	0.0200	2.87		Shallow Concentrated Flow, 30' Shallow Conc. Flow Paved Kv= 20.3 fps
19.1	260	Total			

Subcatchment 14S: Area to CB#3

Hydrograph

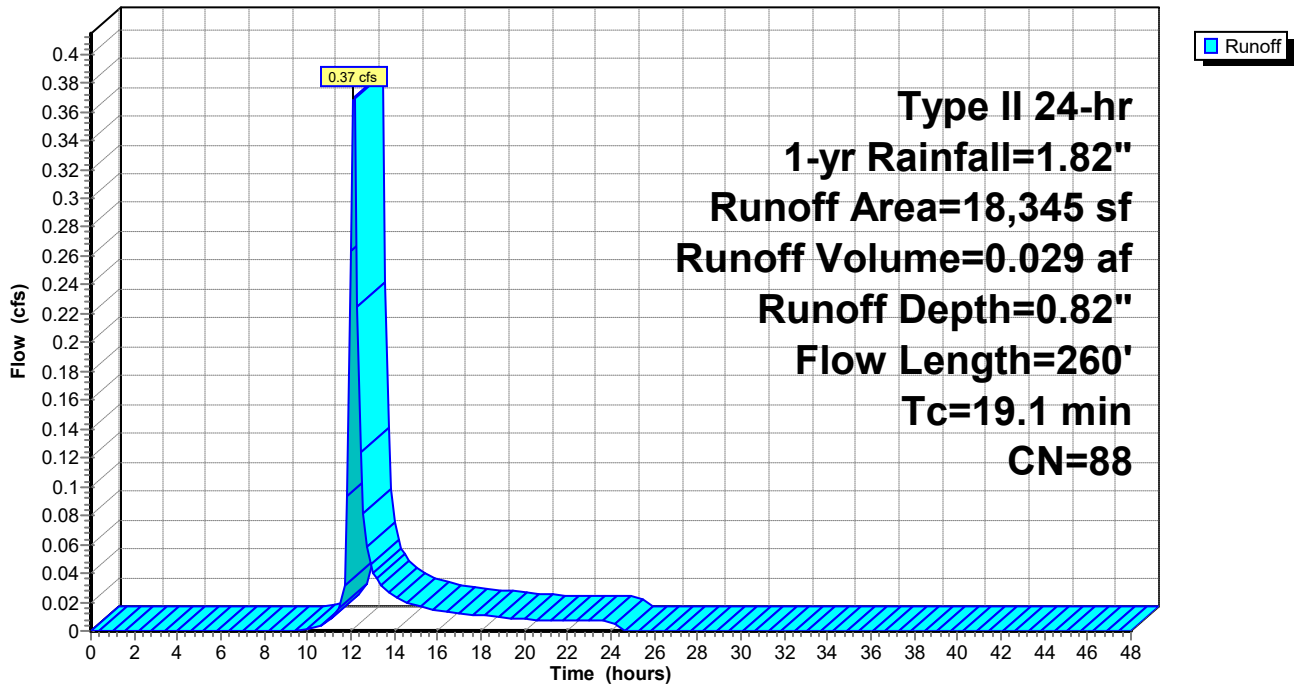

Plug Power - Proposed Conditions 5-15-21

Type II 24-hr 1-yr Rainfall=1.82"

Prepared by {enter your company name here}

Printed 5/20/2021

HydroCAD® 10.10-5a s/n 11585 © 2020 HydroCAD Software Solutions LLC

Page 21

Summary for Subcatchment 18S: Area to YD#2

Runoff = 0.30 cfs @ 12.19 hrs, Volume= 0.028 af, Depth= 0.53"

Runoff by SCS TR-20 method, UH=SCS, Weighted-CN, Time Span= 0.00-48.00 hrs, dt= 0.15 hrs
Type II 24-hr 1-yr Rainfall=1.82"

Area (sf)	CN	Adj	Description
19,675	80		>75% Grass cover, Good, HSG D
7,525	98		Unconnected pavement, HSG D
27,200	85	82	Weighted Average, UI Adjusted
19,675			72.33% Pervious Area
7,525			27.67% Impervious Area
7,525			100.00% Unconnected

Tc (min)	Length (feet)	Slope (ft/ft)	Velocity (ft/sec)	Capacity (cfs)	Description
23.0	100	0.0100	0.07		Sheet Flow, 100' Overland Flow Grass: Dense n= 0.240 P2= 2.14"
0.4	40	0.0100	1.50		Shallow Concentrated Flow, 40' Shallow Conc. Flow Grassed Waterway Kv= 15.0 fps
23.4	140	Total			

Subcatchment 18S: Area to YD#2

Hydrograph

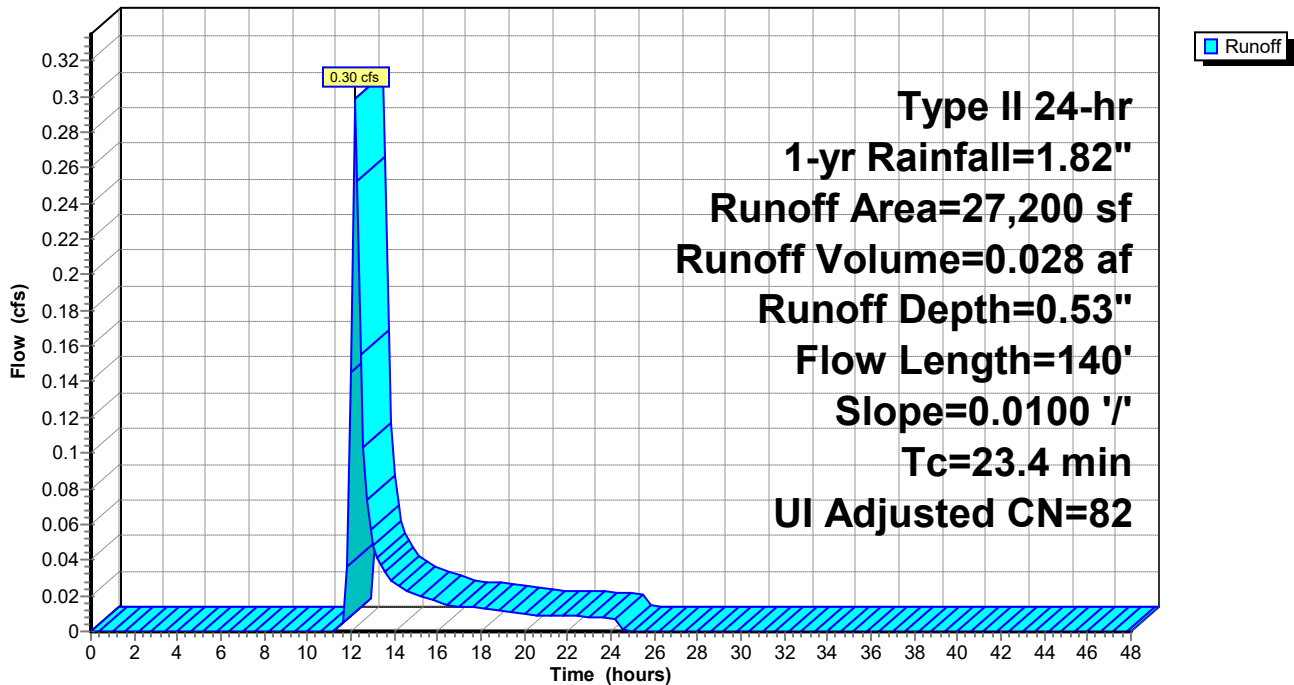

Plug Power - Proposed Conditions 5-15-21

Type II 24-hr 1-yr Rainfall=1.82"

Prepared by {enter your company name here}

Printed 5/20/2021

HydroCAD® 10.10-5a s/n 11585 © 2020 HydroCAD Software Solutions LLC

Page 22

Summary for Subcatchment 20S: Eastern Area Overland to Gravel Storage

Runoff = 6.34 cfs @ 12.26 hrs, Volume= 0.635 af, Depth= 1.01"

Runoff by SCS TR-20 method, UH=SCS, Weighted-CN, Time Span= 0.00-48.00 hrs, dt= 0.15 hrs
Type II 24-hr 1-yr Rainfall=1.82"

Area (sf)	CN	Description
* 77,480	80	Gravel Storage Area, Good, HSG D
80,190	98	Paved parking, HSG D
77,985	98	Roofs, HSG D
47,575	98	Unconnected pavement, HSG D
46,080	80	>75% Grass cover, Good, HSG D
329,310	91	Weighted Average
123,560		37.52% Pervious Area
205,750		62.48% Impervious Area
47,575		23.12% Unconnected

Tc (min)	Length (feet)	Slope (ft/ft)	Velocity (ft/sec)	Capacity (cfs)	Description
16.5	75	0.0130	0.08		Sheet Flow, 75' Overland Flow Grass: Dense n= 0.240 P2= 2.14"
12.3	25	0.0030	0.03		Sheet Flow, 25' Overland Flow Grass: Dense n= 0.240 P2= 2.14"
0.2	30	0.0300	2.60		Shallow Concentrated Flow, 30' Shallow Conc. Flow Grassed Waterway Kv= 15.0 fps
1.2	200	0.0200	2.87		Shallow Concentrated Flow, 200' Shallow Conc. Flow Paved Kv= 20.3 fps
30.2	330	Total			

Subcatchment 20S: Eastern Area Overland to Gravel Storage

Hydrograph

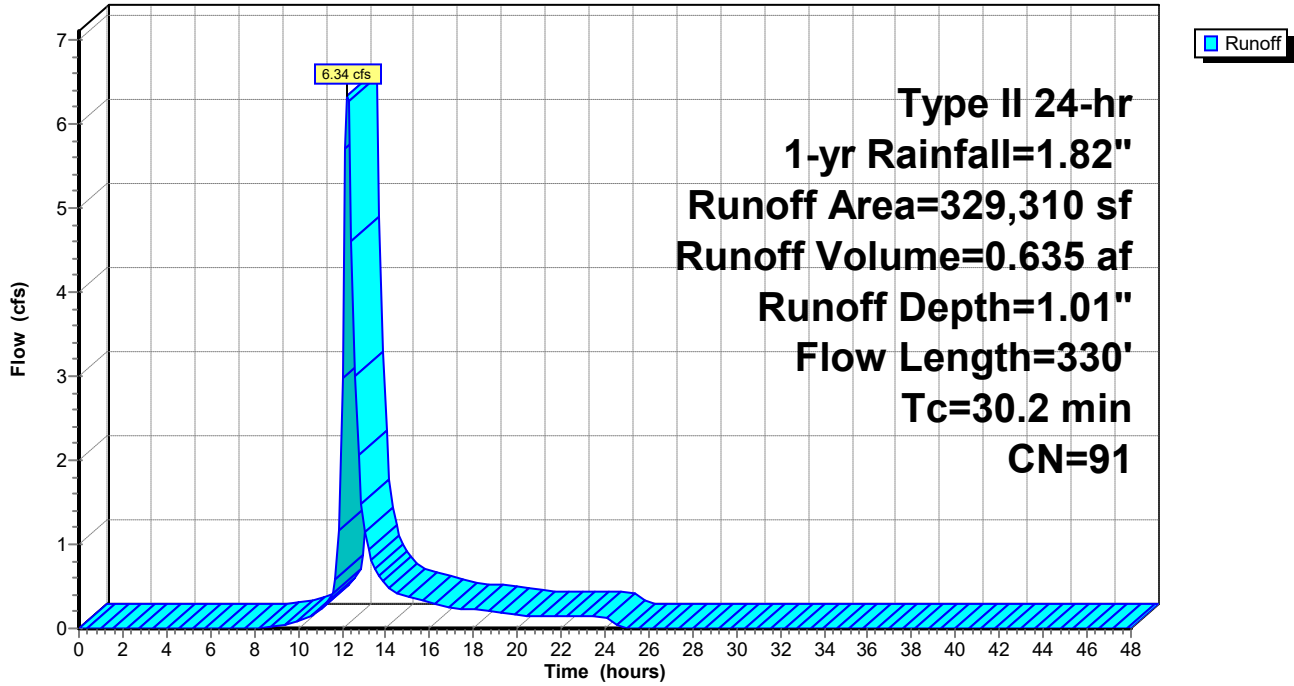

Plug Power - Proposed Conditions 5-15-21

Type II 24-hr 1-yr Rainfall=1.82"

Prepared by {enter your company name here}

Printed 5/20/2021

HydroCAD® 10.10-5a s/n 11585 © 2020 HydroCAD Software Solutions LLC

Page 24

Summary for Subcatchment 24S: Area to YD#11

Runoff = 0.92 cfs @ 12.11 hrs, Volume= 0.070 af, Depth= 0.94"

Runoff by SCS TR-20 method, UH=SCS, Weighted-CN, Time Span= 0.00-48.00 hrs, dt= 0.15 hrs
Type II 24-hr 1-yr Rainfall=1.82"

Area (sf)	CN	Description
3,925	98	Paved parking, HSG D
17,935	80	>75% Grass cover, Good, HSG D
17,040	98	Roofs, HSG D
38,900	90	Weighted Average
17,935		46.11% Pervious Area
20,965		53.89% Impervious Area

Tc (min)	Length (feet)	Slope (ft/ft)	Velocity (ft/sec)	Capacity (cfs)	Description
17.3	70	0.0100	0.07		Sheet Flow, 70' Overland Flow Grass: Dense n= 0.240 P2= 2.14"

Subcatchment 24S: Area to YD#11

Hydrograph

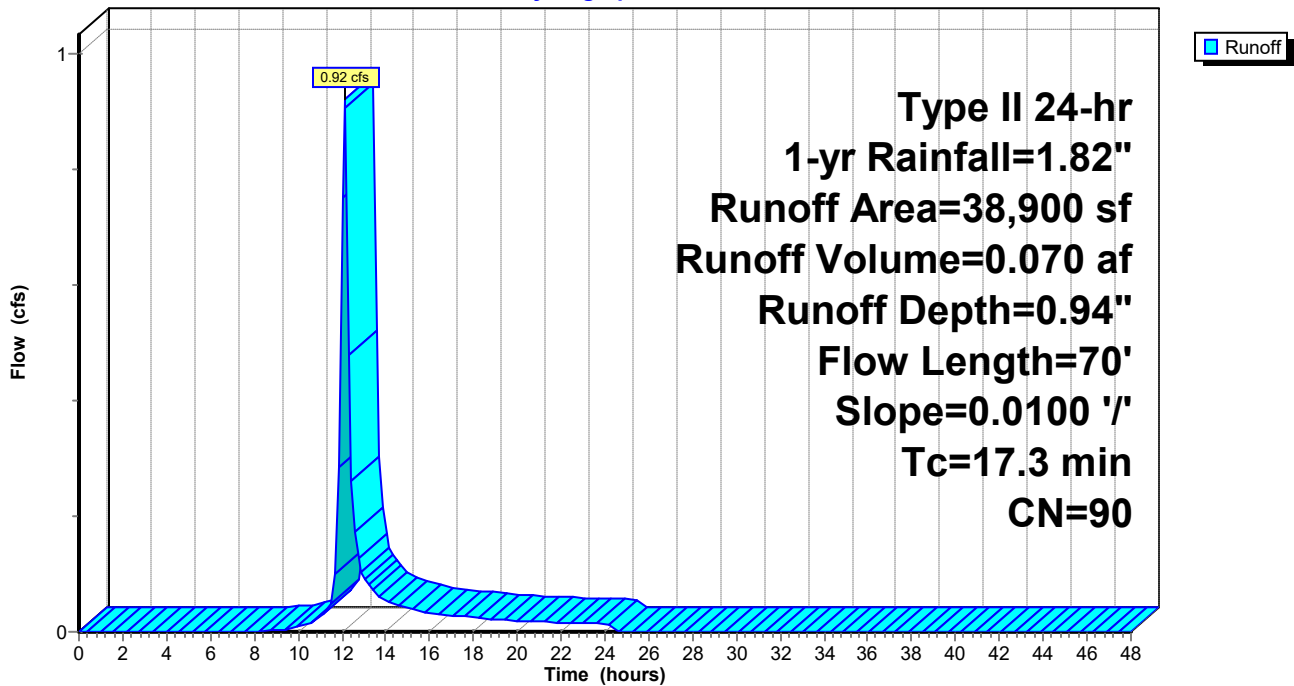

Plug Power - Proposed Conditions 5-15-21

Type II 24-hr 1-yr Rainfall=1.82"

Prepared by {enter your company name here}

Printed 5/20/2021

HydroCAD® 10.10-5a s/n 11585 © 2020 HydroCAD Software Solutions LLC

Page 25

Summary for Subcatchment 26S: Area to CB#4

Runoff = 1.05 cfs @ 12.11 hrs, Volume= 0.079 af, Depth= 1.01"

Runoff by SCS TR-20 method, UH=SCS, Weighted-CN, Time Span= 0.00-48.00 hrs, dt= 0.15 hrs
Type II 24-hr 1-yr Rainfall=1.82"

Area (sf)	CN	Description
510	98	Roofs, HSG D
25,120	98	Paved parking, HSG D
15,575	80	>75% Grass cover, Good, HSG D
41,205	91	Weighted Average
15,575		37.80% Pervious Area
25,630		62.20% Impervious Area

Tc (min)	Length (feet)	Slope (ft/ft)	Velocity (ft/sec)	Capacity (cfs)	Description
16.3	65	0.0100	0.07		Sheet Flow, 65' Overland Flow
					Grass: Dense n= 0.240 P2= 2.14"
0.6	35	0.0200	0.91		Sheet Flow, 35' Overland Flow
					Smooth surfaces n= 0.011 P2= 2.14"
16.9	100	Total			

Subcatchment 26S: Area to CB#4

Hydrograph

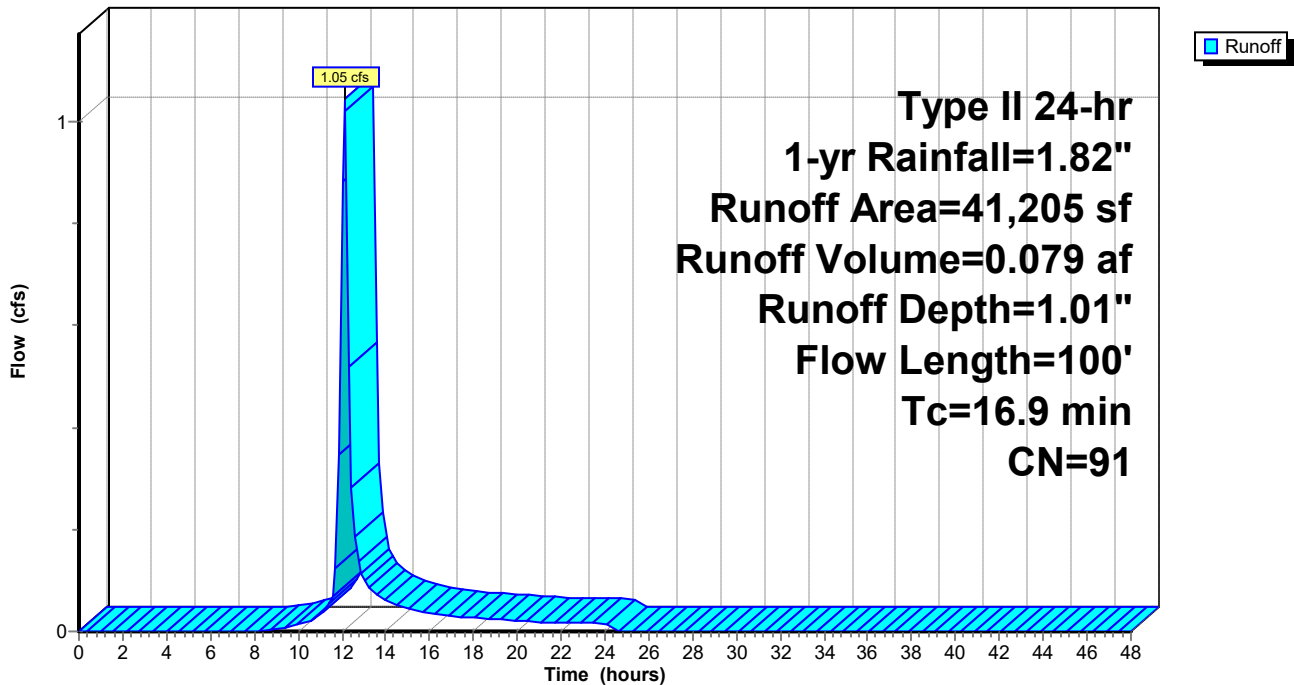

Plug Power - Proposed Conditions 5-15-21

Type II 24-hr 1-yr Rainfall=1.82"

Prepared by {enter your company name here}

Printed 5/20/2021

HydroCAD® 10.10-5a s/n 11585 © 2020 HydroCAD Software Solutions LLC

Page 26

Summary for Subcatchment 29S: Area to CB#15

Runoff = 0.80 cfs @ 11.95 hrs, Volume= 0.052 af, Depth= 1.60"

Runoff by SCS TR-20 method, UH=SCS, Weighted-CN, Time Span= 0.00-48.00 hrs, dt= 0.15 hrs
Type II 24-hr 1-yr Rainfall=1.82"

Area (sf)	CN	Description
17,040	98	Roofs, HSG D
17,040		100.00% Impervious Area

Tc (min)	Length (feet)	Slope (ft/ft)	Velocity (ft/sec)	Capacity (cfs)	Description
5.0					Direct Entry,

Subcatchment 29S: Area to CB#15

Hydrograph

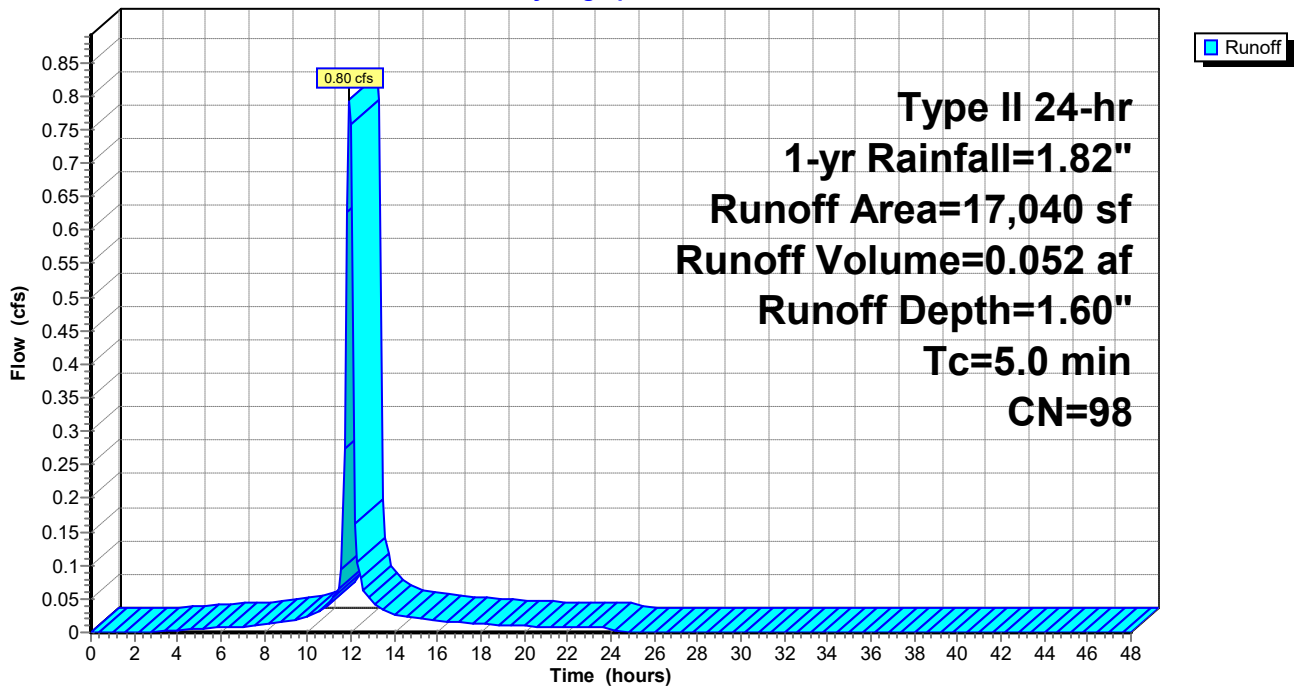

Plug Power - Proposed Conditions 5-15-21

Type II 24-hr 1-yr Rainfall=1.82"

Prepared by {enter your company name here}

Printed 5/20/2021

HydroCAD® 10.10-5a s/n 11585 © 2020 HydroCAD Software Solutions LLC

Page 27

Summary for Subcatchment 30S: Area to CB#18

Runoff = 0.20 cfs @ 12.20 hrs, Volume= 0.019 af, Depth= 0.49"

Runoff by SCS TR-20 method, UH=SCS, Weighted-CN, Time Span= 0.00-48.00 hrs, dt= 0.15 hrs
Type II 24-hr 1-yr Rainfall=1.82"

Area (sf)	CN	Adj	Description
3,025	98		Unconnected pavement, HSG D
17,075	80		>75% Grass cover, Good, HSG D
20,100	83	81	Weighted Average, UI Adjusted
17,075			84.95% Pervious Area
3,025			15.05% Impervious Area
3,025			100.00% Unconnected

Tc (min)	Length (feet)	Slope (ft/ft)	Velocity (ft/sec)	Capacity (cfs)	Description
23.0	100	0.0100	0.07		Sheet Flow, 100' Overland Flow
					Grass: Dense n= 0.240 P2= 2.14"
0.4	40	0.0100	1.50		Shallow Concentrated Flow, 40' Shallow Conc. Flow
					Grassed Waterway Kv= 15.0 fps
23.4	140	Total			

Subcatchment 30S: Area to CB#18

Hydrograph

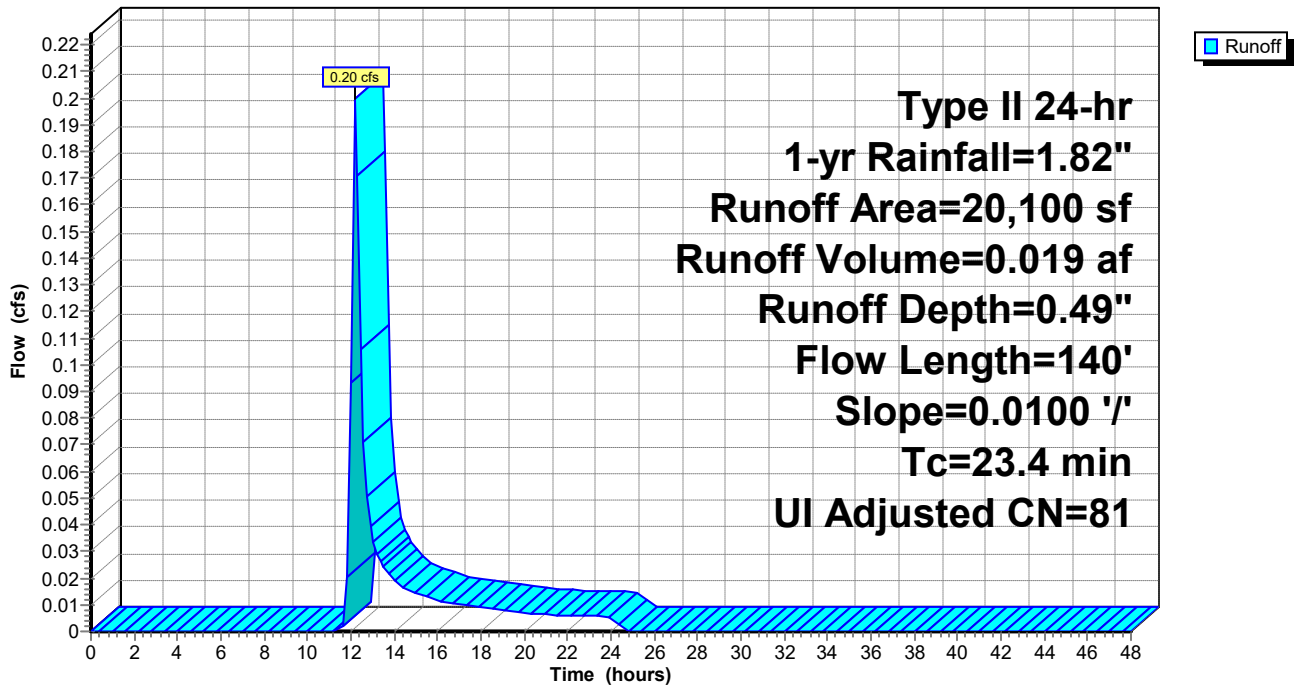

Plug Power - Proposed Conditions 5-15-21

Type II 24-hr 1-yr Rainfall=1.82"

Prepared by {enter your company name here}

Printed 5/20/2021

HydroCAD® 10.10-5a s/n 11585 © 2020 HydroCAD Software Solutions LLC

Page 28

Summary for Subcatchment 32S: Area to CB#7

Runoff = 0.98 cfs @ 12.10 hrs, Volume= 0.075 af, Depth= 1.08"

Runoff by SCS TR-20 method, UH=SCS, Weighted-CN, Time Span= 0.00-48.00 hrs, dt= 0.15 hrs
Type II 24-hr 1-yr Rainfall=1.82"

Area (sf)	CN	Description
25,120	98	Paved parking, HSG D
11,100	80	>75% Grass cover, Good, HSG D
36,220	92	Weighted Average
11,100		30.65% Pervious Area
25,120		69.35% Impervious Area

Tc (min)	Length (feet)	Slope (ft/ft)	Velocity (ft/sec)	Capacity (cfs)	Description
16.3	65	0.0100	0.07		Sheet Flow, 65' Overland Flow
					Grass: Dense n= 0.240 P2= 2.14"
0.6	35	0.0200	0.91		Sheet Flow, 35' Overland Flow
					Smooth surfaces n= 0.011 P2= 2.14"
16.9	100	Total			

Subcatchment 32S: Area to CB#7

Hydrograph

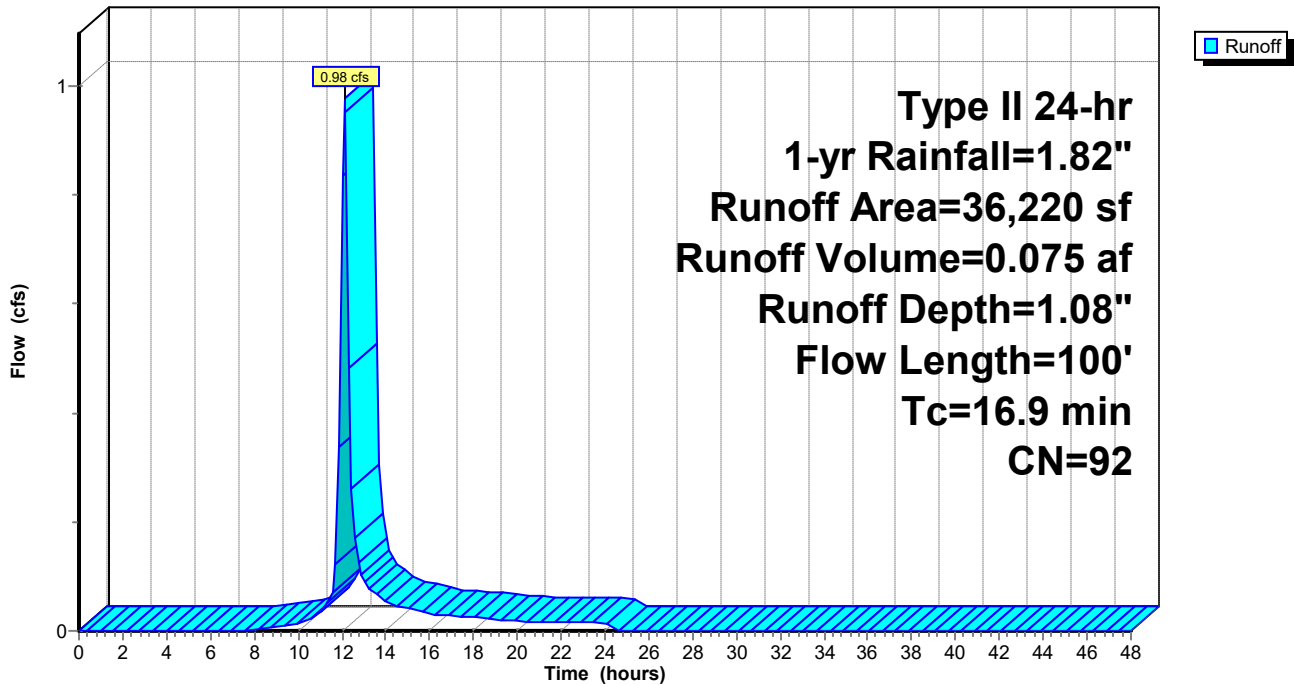

Plug Power - Proposed Conditions 5-15-21

Type II 24-hr 1-yr Rainfall=1.82"

Prepared by {enter your company name here}

Printed 5/20/2021

HydroCAD® 10.10-5a s/n 11585 © 2020 HydroCAD Software Solutions LLC

Page 29

Summary for Subcatchment 36S: Area to CB#9

Runoff = 0.37 cfs @ 12.14 hrs, Volume= 0.029 af, Depth= 0.82"

Runoff by SCS TR-20 method, UH=SCS, Weighted-CN, Time Span= 0.00-48.00 hrs, dt= 0.15 hrs
Type II 24-hr 1-yr Rainfall=1.82"

Area (sf)	CN	Description
5,755	98	Paved parking, HSG D
2,520	98	Unconnected pavement, HSG D
10,200	80	>75% Grass cover, Good, HSG D
18,475	88	Weighted Average
10,200		55.21% Pervious Area
8,275		44.79% Impervious Area
2,520		30.45% Unconnected

Tc (min)	Length (feet)	Slope (ft/ft)	Velocity (ft/sec)	Capacity (cfs)	Description
19.3	80	0.0100	0.07		Sheet Flow, 80' Overland Flow Grass: Dense n= 0.240 P2= 2.14"

Subcatchment 36S: Area to CB#9

Hydrograph

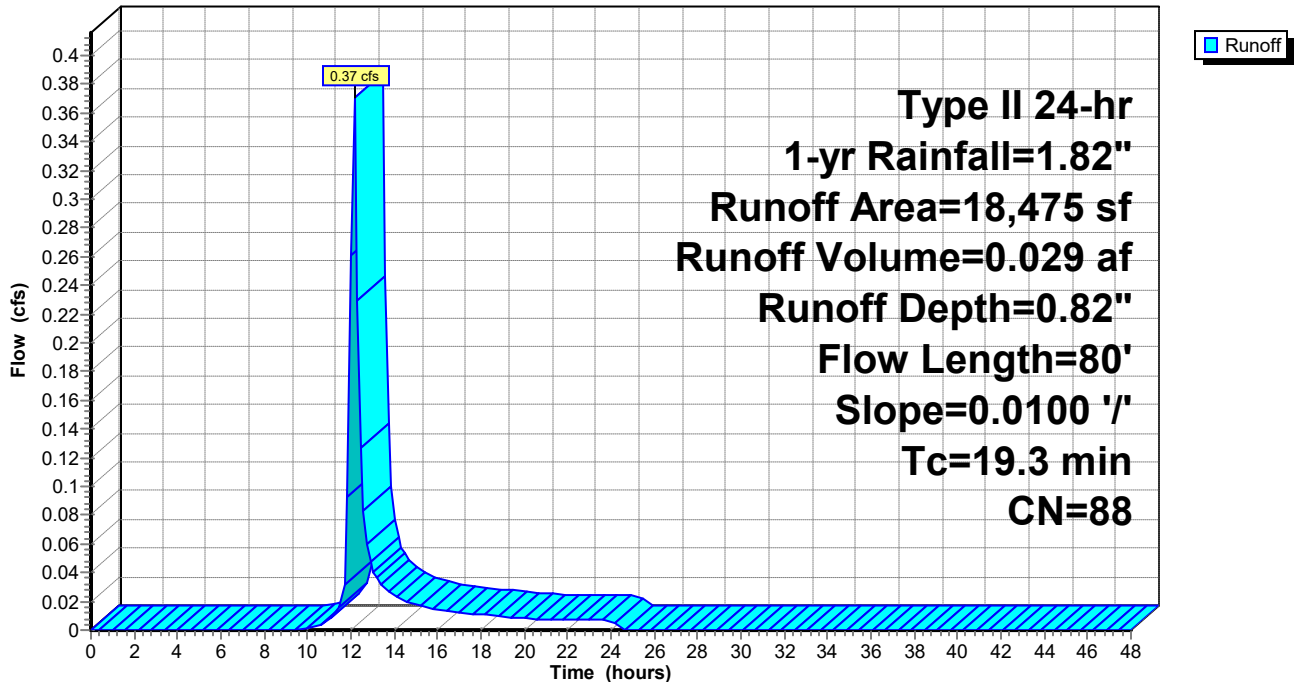

Plug Power - Proposed Conditions 5-15-21

Type II 24-hr 1-yr Rainfall=1.82"

Prepared by {enter your company name here}

Printed 5/20/2021

HydroCAD® 10.10-5a s/n 11585 © 2020 HydroCAD Software Solutions LLC

Page 30

Summary for Subcatchment 38S: Area to CB#10

Runoff = 0.52 cfs @ 12.16 hrs, Volume= 0.044 af, Depth= 0.58"

Runoff by SCS TR-20 method, UH=SCS, Weighted-CN, Time Span= 0.00-48.00 hrs, dt= 0.15 hrs
Type II 24-hr 1-yr Rainfall=1.82"

Area (sf)	CN	Description
8,155	79	Woods, Fair, HSG D
5,920	78	Meadow, non-grazed, HSG D
6,730	98	Paved parking, HSG D
18,845	80	>75% Grass cover, Good, HSG D
39,650	83	Weighted Average
32,920		83.03% Pervious Area
6,730		16.97% Impervious Area

Tc (min)	Length (feet)	Slope (ft/ft)	Velocity (ft/sec)	Capacity (cfs)	Description
20.1	100	0.0140	0.08		Sheet Flow, 100' Overland Flow Grass: Dense n= 0.240 P2= 2.14"
0.5	50	0.0140	1.77		Shallow Concentrated Flow, 50' Shallow Conc. Flow Grassed Waterway Kv= 15.0 fps
20.6	150	Total			

Subcatchment 38S: Area to CB#10

Hydrograph

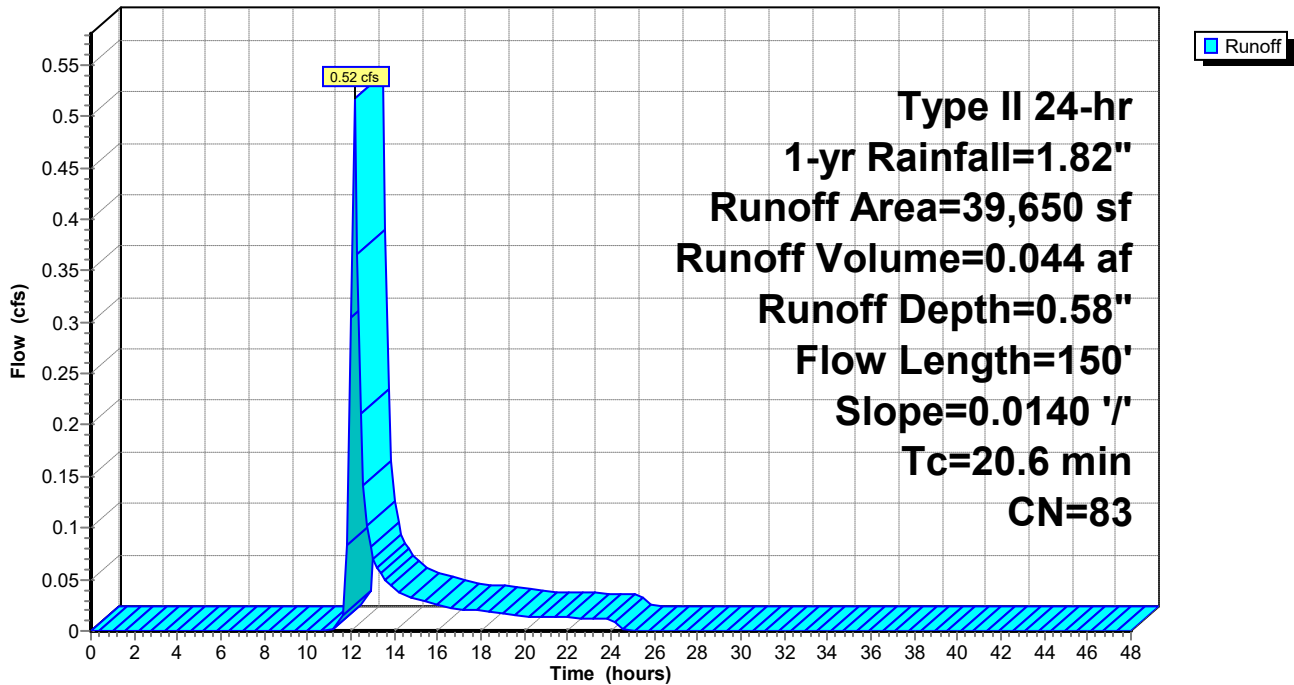

Plug Power - Proposed Conditions 5-15-21

Type II 24-hr 1-yr Rainfall=1.82"

Prepared by {enter your company name here}

Printed 5/20/2021

HydroCAD® 10.10-5a s/n 11585 © 2020 HydroCAD Software Solutions LLC

Page 31

Summary for Subcatchment 40S: Area to CB#11

Runoff = 1.09 cfs @ 12.15 hrs, Volume= 0.096 af, Depth= 1.60"

Runoff by SCS TR-20 method, UH=SCS, Weighted-CN, Time Span= 0.00-48.00 hrs, dt= 0.15 hrs
Type II 24-hr 1-yr Rainfall=1.82"

Area (sf)	CN	Description
4,960	98	Paved parking, HSG D
26,535	98	Paved parking, HSG D
31,495	98	Weighted Average
31,495		100.00% Impervious Area

Tc (min)	Length (feet)	Slope (ft/ft)	Velocity (ft/sec)	Capacity (cfs)	Description
21.4	100	0.0120	0.08		Sheet Flow, 100' Overland Flow Grass: Dense n= 0.240 P2= 2.14"
0.7	70	0.0120	1.64		Shallow Concentrated Flow, 70' Shallow Conc. Flow Grassed Waterway Kv= 15.0 fps
22.1	170	Total			

Subcatchment 40S: Area to CB#11

Hydrograph

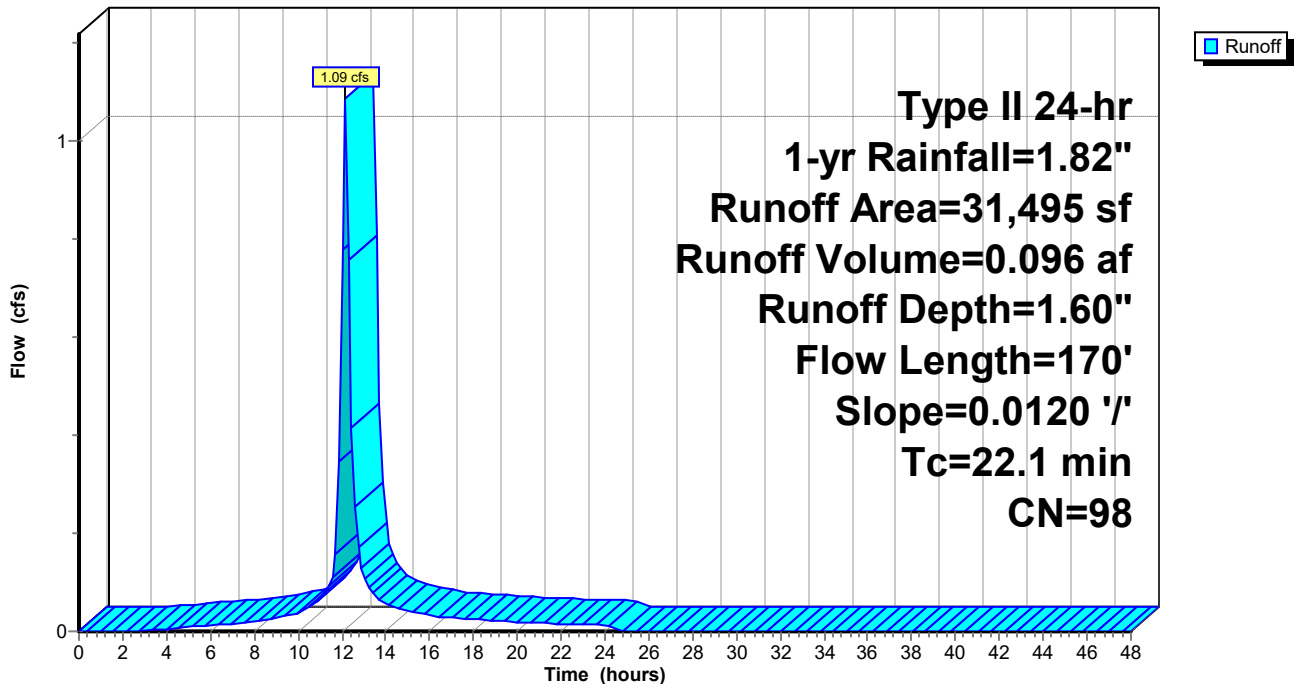

Plug Power - Proposed Conditions 5-15-21

Type II 24-hr 1-yr Rainfall=1.82"

Prepared by {enter your company name here}

Printed 5/20/2021

HydroCAD® 10.10-5a s/n 11585 © 2020 HydroCAD Software Solutions LLC

Page 32

Summary for Subcatchment 42S: Western Area Overland to Gravel Storage

Runoff = 3.93 cfs @ 11.98 hrs, Volume= 0.220 af, Depth= 0.82"

Runoff by SCS TR-20 method, UH=SCS, Weighted-CN, Time Span= 0.00-48.00 hrs, dt= 0.15 hrs
Type II 24-hr 1-yr Rainfall=1.82"

Area (sf)	CN	Description
* 53,390	80	Gravel Storage Area, Good, HSG D
31,080	98	Paved parking, HSG D
2,460	98	Unconnected pavement, HSG D
26,630	80	>75% Grass cover, Good, HSG D
26,105	98	Roofs, HSG D
139,665	88	Weighted Average
80,020		57.29% Pervious Area
59,645		42.71% Impervious Area
2,460		4.12% Unconnected

Tc (min)	Length (feet)	Slope (ft/ft)	Velocity (ft/sec)	Capacity (cfs)	Description
5.8	25	0.0200	0.07		Sheet Flow, 25' Overland Flow Grass: Dense n= 0.240 P2= 2.14"
0.5	25	0.0200	0.85		Sheet Flow, 25' Overland Flow Smooth surfaces n= 0.011 P2= 2.14"
6.3	50	Total			

Subcatchment 42S: Western Area Overland to Gravel Storage

Hydrograph

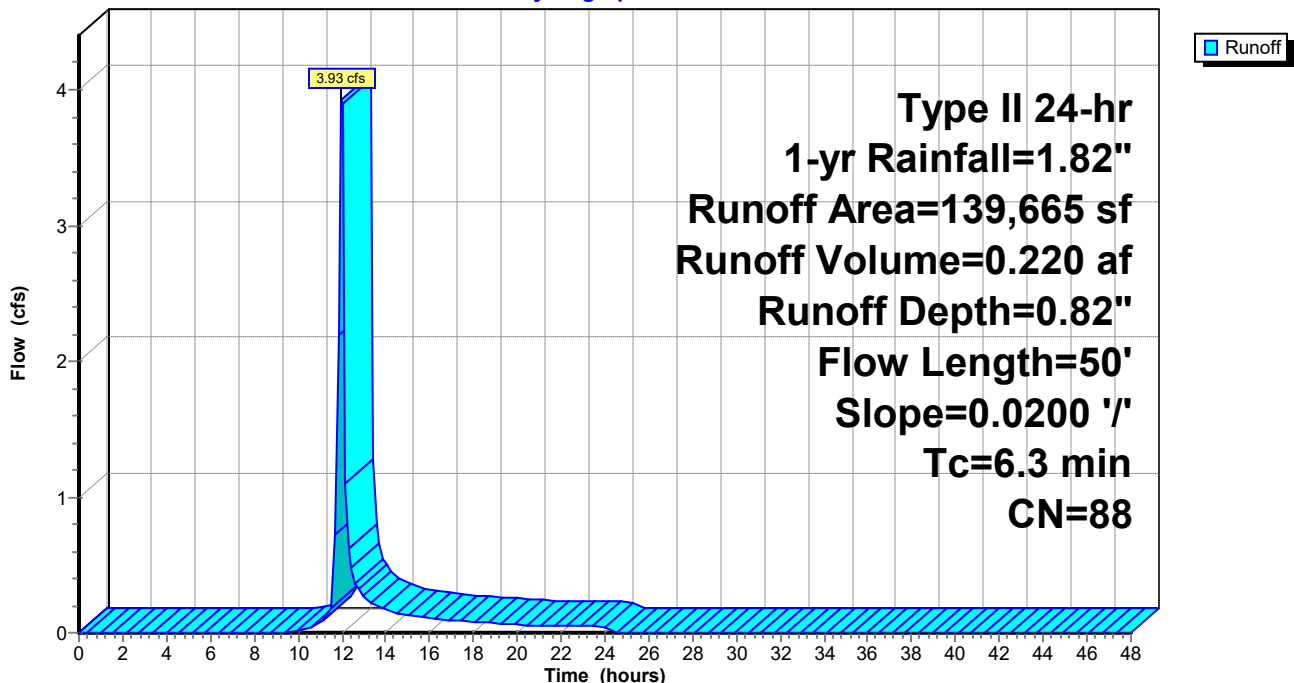

Plug Power - Proposed Conditions 5-15-21

Type II 24-hr 1-yr Rainfall=1.82"

Prepared by {enter your company name here}

Printed 5/20/2021

HydroCAD® 10.10-5a s/n 11585 © 2020 HydroCAD Software Solutions LLC

Page 33

Summary for Subcatchment 43S: North Half of Phase 2 Building

Runoff = 1.70 cfs @ 11.95 hrs, Volume= 0.111 af, Depth= 1.60"

Runoff by SCS TR-20 method, UH=SCS, Weighted-CN, Time Span= 0.00-48.00 hrs, dt= 0.15 hrs
Type II 24-hr 1-yr Rainfall=1.82"

Area (sf)	CN	Description
36,505	98	Roofs, HSG D
36,505		100.00% Impervious Area

Tc (min)	Length (feet)	Slope (ft/ft)	Velocity (ft/sec)	Capacity (cfs)	Description
5.0					Direct Entry,

Subcatchment 43S: North Half of Phase 2 Building

Hydrograph

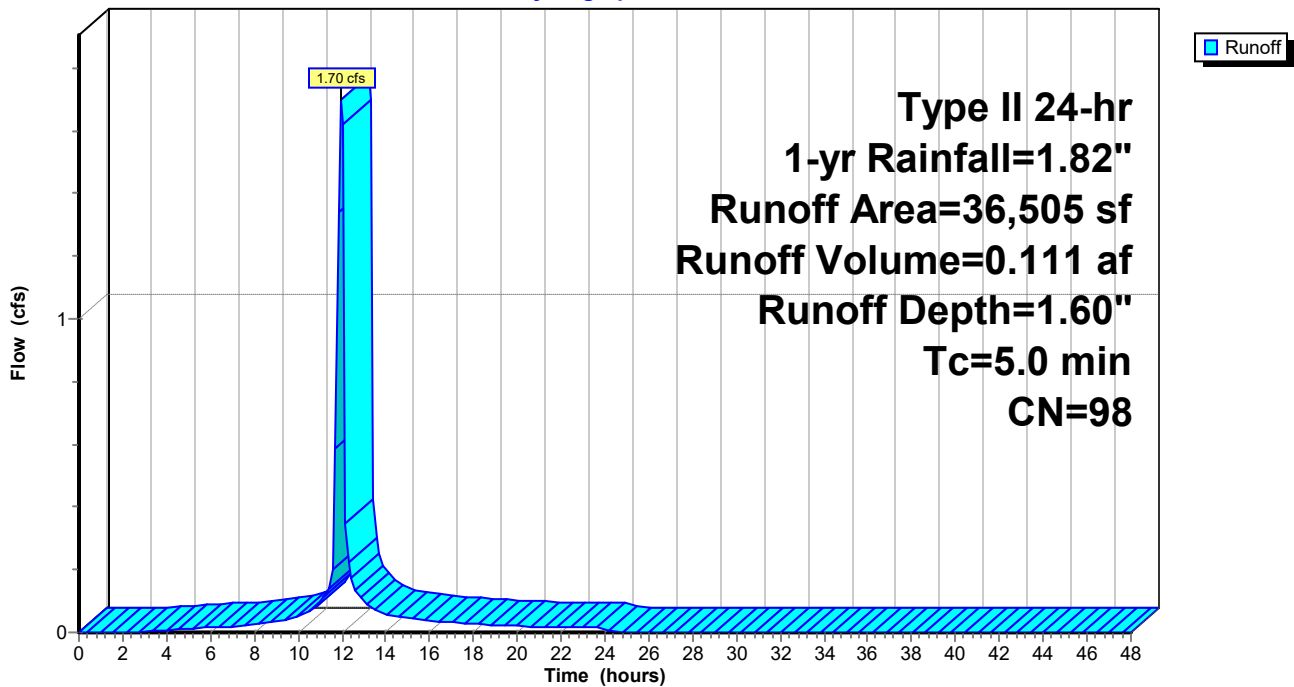

Plug Power - Proposed Conditions 5-15-21

Type II 24-hr 1-yr Rainfall=1.82"

Prepared by {enter your company name here}

Printed 5/20/2021

HydroCAD® 10.10-5a s/n 11585 © 2020 HydroCAD Software Solutions LLC

Page 34

Summary for Subcatchment 45S: South Half of Phase 2 Building

Runoff = 1.51 cfs @ 11.95 hrs, Volume= 0.099 af, Depth= 1.60"

Runoff by SCS TR-20 method, UH=SCS, Weighted-CN, Time Span= 0.00-48.00 hrs, dt= 0.15 hrs
Type II 24-hr 1-yr Rainfall=1.82"

Area (sf)	CN	Description
32,290	98	Roofs, HSG D
32,290		100.00% Impervious Area

Tc (min)	Length (feet)	Slope (ft/ft)	Velocity (ft/sec)	Capacity (cfs)	Description
5.0					Direct Entry,

Subcatchment 45S: South Half of Phase 2 Building

Hydrograph

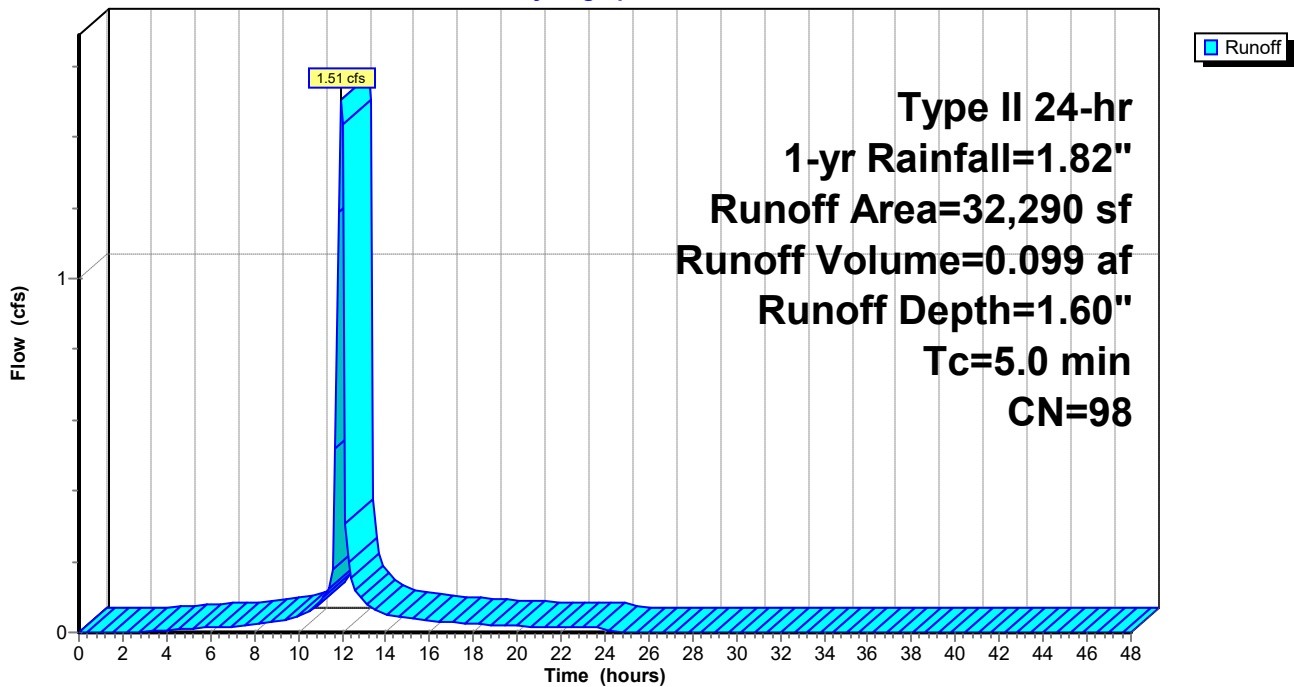

Plug Power - Proposed Conditions 5-15-21

Type II 24-hr 1-yr Rainfall=1.82"

Prepared by {enter your company name here}

Printed 5/20/2021

HydroCAD® 10.10-5a s/n 11585 © 2020 HydroCAD Software Solutions LLC

Page 35

Summary for Subcatchment 48S: Area to YD#1

Runoff = 0.57 cfs @ 12.18 hrs, Volume= 0.050 af, Depth= 0.77"

Runoff by SCS TR-20 method, UH=SCS, Weighted-CN, Time Span= 0.00-48.00 hrs, dt= 0.15 hrs
Type II 24-hr 1-yr Rainfall=1.82"

Area (sf)	CN	Description
2,610	98	Roofs, HSG D
21,165	80	>75% Grass cover, Good, HSG D
10,255	98	Paved parking, HSG D
34,030	87	Weighted Average
21,165		62.20% Pervious Area
12,865		37.80% Impervious Area

Tc (min)	Length (feet)	Slope (ft/ft)	Velocity (ft/sec)	Capacity (cfs)	Description
23.0	100	0.0100	0.07		Sheet Flow, 100' Overland Flow
					Grass: Dense n= 0.240 P2= 2.14"
0.6	50	0.0100	1.50		Shallow Concentrated Flow, 50' Shallow Conc. Flow
					Grassed Waterway Kv= 15.0 fps
23.6	150	Total			

Subcatchment 48S: Area to YD#1

Hydrograph

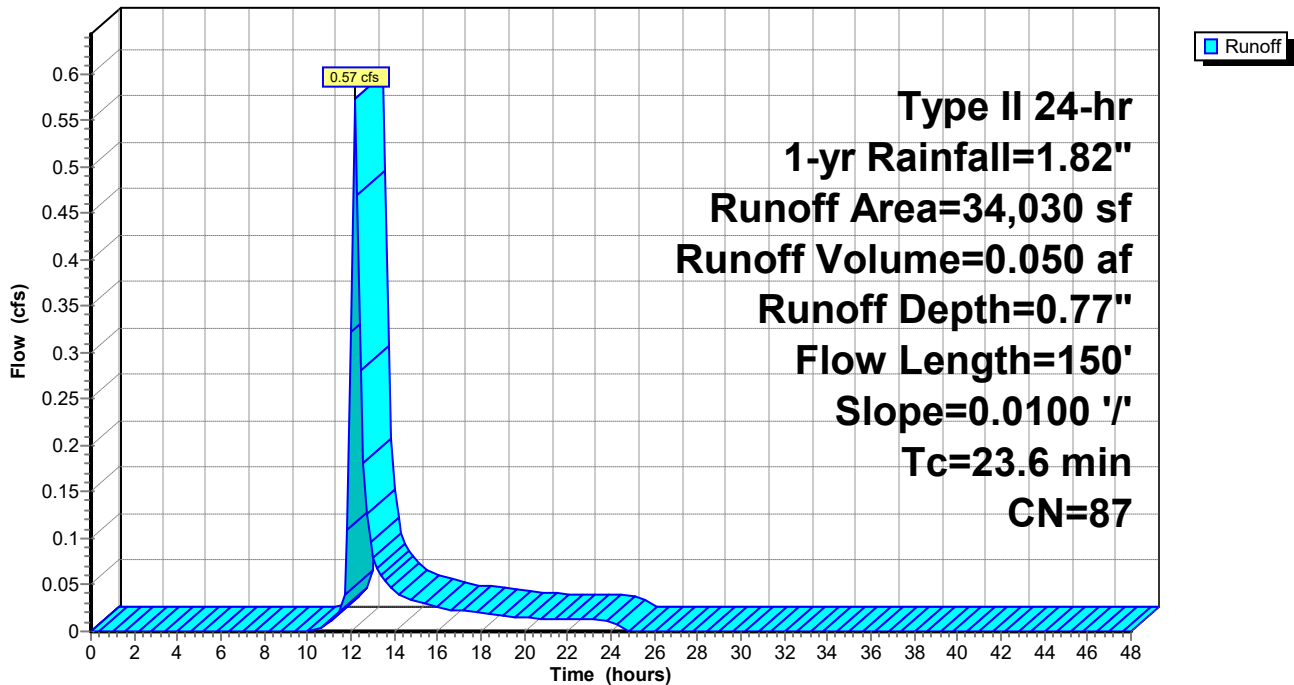

Plug Power - Proposed Conditions 5-15-21

Type II 24-hr 1-yr Rainfall=1.82"

Prepared by {enter your company name here}

Printed 5/20/2021

HydroCAD® 10.10-5a s/n 11585 © 2020 HydroCAD Software Solutions LLC

Page 36

Summary for Subcatchment 49S: Area to YD#3

Runoff = 1.12 cfs @ 12.21 hrs, Volume= 0.104 af, Depth= 0.67"

Runoff by SCS TR-20 method, UH=SCS, Weighted-CN, Time Span= 0.00-48.00 hrs, dt= 0.15 hrs
Type II 24-hr 1-yr Rainfall=1.82"

Area (sf)	CN	Description
20,040	98	Paved parking, HSG D
57,195	80	>75% Grass cover, Good, HSG D
4,600	98	Roofs, HSG D
81,835	85	Weighted Average
57,195		69.89% Pervious Area
24,640		30.11% Impervious Area

Tc (min)	Length (feet)	Slope (ft/ft)	Velocity (ft/sec)	Capacity (cfs)	Description
23.0	100	0.0100	0.07		Sheet Flow, 100' Overland Flow Grass: Dense n= 0.240 P2= 2.14"
0.3	60	0.0200	2.87		Shallow Concentrated Flow, 60' Shallow Conc. Flow Paved Kv= 20.3 fps
2.0	180	0.0100	1.50		Shallow Concentrated Flow, 180' Shallow Conc. Flow Grassed Waterway Kv= 15.0 fps
25.3	340	Total			

Subcatchment 49S: Area to YD#3

Hydrograph

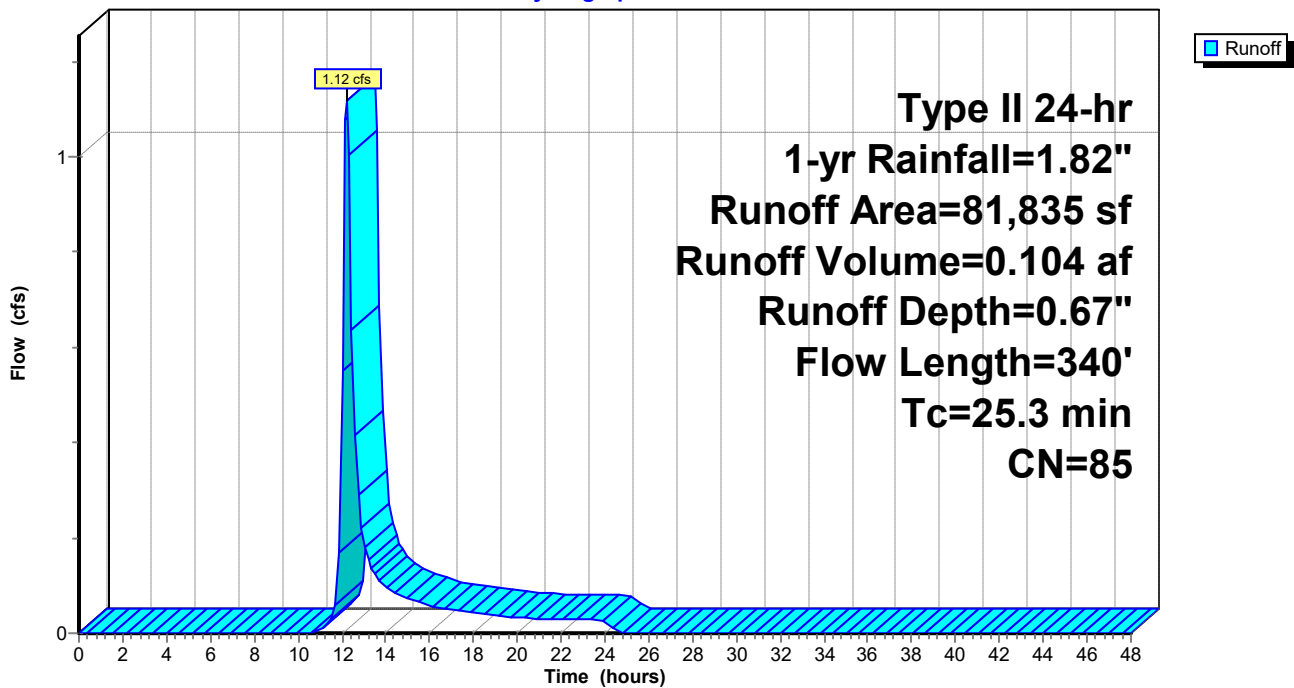

Plug Power - Proposed Conditions 5-15-21

Prepared by {enter your company name here}

HydroCAD® 10.10-5a s/n 11585 © 2020 HydroCAD Software Solutions LLC

Type II 24-hr 1-yr Rainfall=1.82"

Printed 5/20/2021

Page 37

Summary for Subcatchment 52S: Area Overland to Bio-Retention Area

Runoff = 1.06 cfs @ 11.99 hrs, Volume= 0.062 af, Depth= 0.46"

Runoff by SCS TR-20 method, UH=SCS, Weighted-CN, Time Span= 0.00-48.00 hrs, dt= 0.15 hrs
Type II 24-hr 1-yr Rainfall=1.82"

Area (sf)	CN	Description
71,325	80	>75% Grass cover, Good, HSG D
71,325		100.00% Pervious Area

Tc (min)	Length (feet)	Slope (ft/ft)	Velocity (ft/sec)	Capacity (cfs)	Description
3.6	10	0.0100	0.05		Sheet Flow, 10' Overland Flow Grass: Dense n= 0.240 P2= 2.14"
1.8	20	0.2500	0.19		Sheet Flow, 20' Overland Flow Grass: Dense n= 0.240 P2= 2.14"
5.4	30	Total			

Subcatchment 52S: Area Overland to Bio-Retention Area

Hydrograph

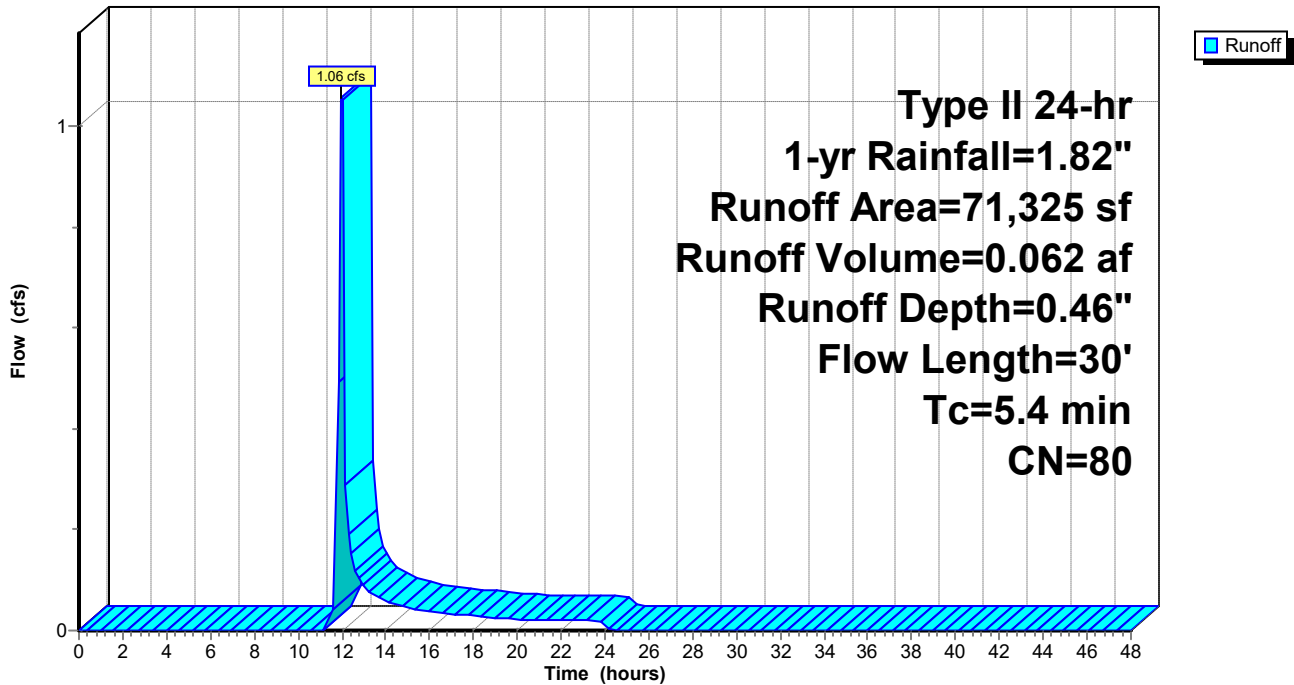

Plug Power - Proposed Conditions 5-15-21

Type II 24-hr 1-yr Rainfall=1.82"

Prepared by {enter your company name here}

Printed 5/20/2021

HydroCAD® 10.10-5a s/n 11585 © 2020 HydroCAD Software Solutions LLC

Page 38

Summary for Subcatchment 53S: Area Overland to Western Swale to Bio-Retention Area

Runoff = 0.09 cfs @ 11.99 hrs, Volume= 0.005 af, Depth= 0.46"

Runoff by SCS TR-20 method, UH=SCS, Weighted-CN, Time Span= 0.00-48.00 hrs, dt= 0.15 hrs
Type II 24-hr 1-yr Rainfall=1.82"

Area (sf)	CN	Description
5,925	80	>75% Grass cover, Good, HSG D
5,925		100.00% Pervious Area

Tc (min)	Length (feet)	Slope (ft/ft)	Velocity (ft/sec)	Capacity (cfs)	Description
5.0					Direct Entry,

Subcatchment 53S: Area Overland to Western Swale to Bio-Retention Area

Hydrograph

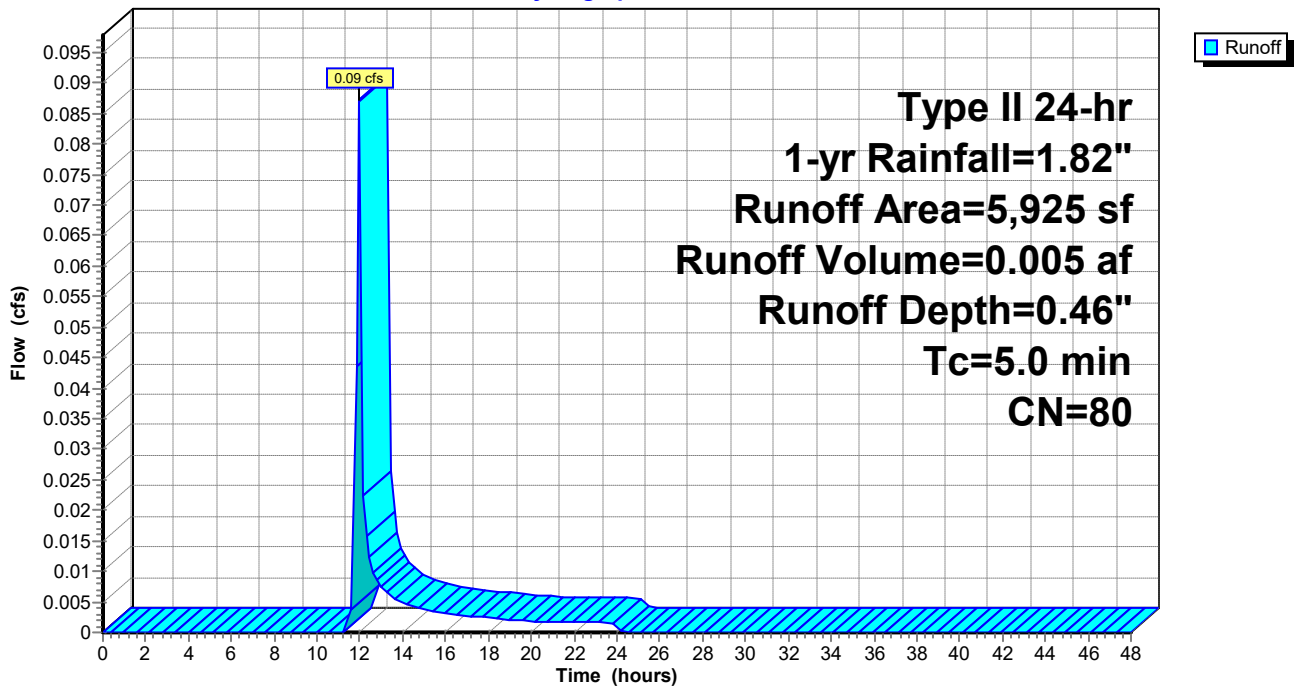

Plug Power - Proposed Conditions 5-15-21

Prepared by {enter your company name here}

HydroCAD® 10.10-5a s/n 11585 © 2020 HydroCAD Software Solutions LLC

Type II 24-hr 1-yr Rainfall=1.82"

Printed 5/20/2021

Page 39

Summary for Subcatchment 54S: Area Overland to Northern Swale to Bio-Retention Area

Runoff = 0.09 cfs @ 11.99 hrs, Volume= 0.005 af, Depth= 0.46"

Runoff by SCS TR-20 method, UH=SCS, Weighted-CN, Time Span= 0.00-48.00 hrs, dt= 0.15 hrs
Type II 24-hr 1-yr Rainfall=1.82"

Area (sf)	CN	Description
6,040	80	>75% Grass cover, Good, HSG D
6,040		100.00% Pervious Area

Tc (min)	Length (feet)	Slope (ft/ft)	Velocity (ft/sec)	Capacity (cfs)	Description
5.0					Direct Entry,

Subcatchment 54S: Area Overland to Northern Swale to Bio-Retention Area

Hydrograph

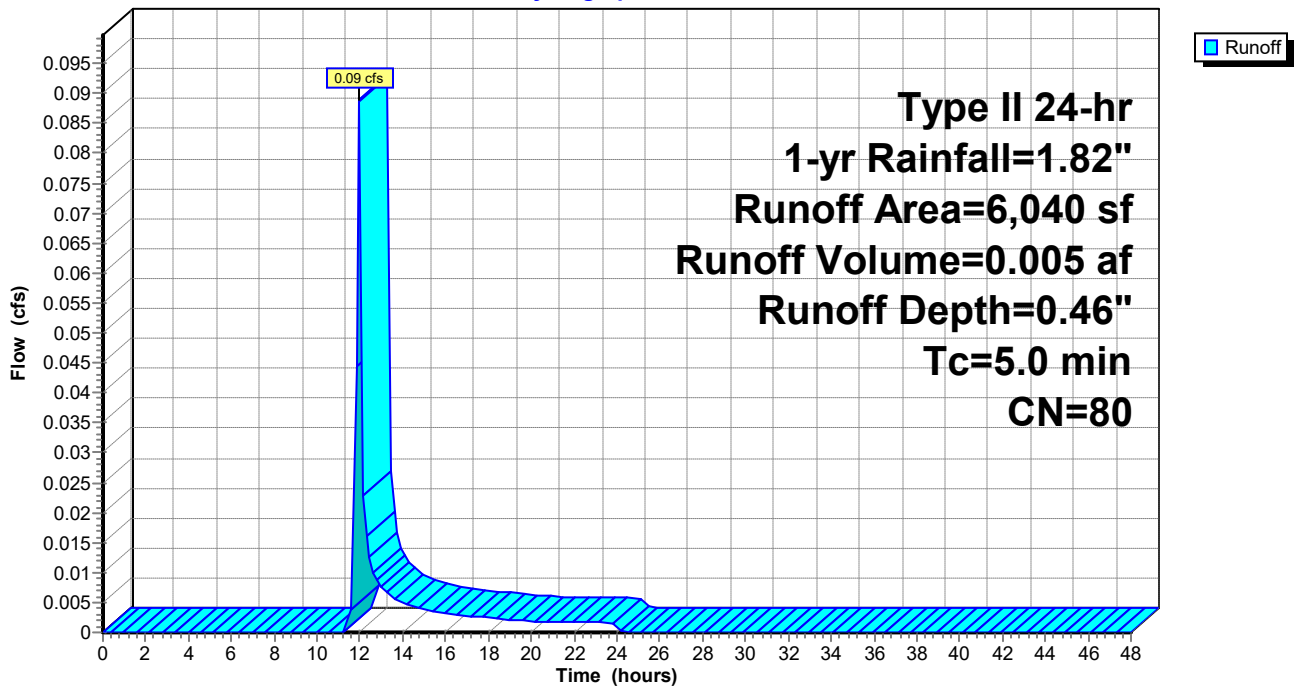

Plug Power - Proposed Conditions 5-15-21

Type II 24-hr 1-yr Rainfall=1.82"

Prepared by {enter your company name here}

Printed 5/20/2021

HydroCAD® 10.10-5a s/n 11585 © 2020 HydroCAD Software Solutions LLC

Page 40

Summary for Subcatchment 55S: Area Overland to Swales to Dry Pond

Runoff = 0.19 cfs @ 12.00 hrs, Volume= 0.012 af, Depth= 0.46"

Runoff by SCS TR-20 method, UH=SCS, Weighted-CN, Time Span= 0.00-48.00 hrs, dt= 0.15 hrs
 Type II 24-hr 1-yr Rainfall=1.82"

Area (sf)	CN	Description
13,210	80	>75% Grass cover, Good, HSG D
13,210		100.00% Pervious Area

Tc (min)	Length (feet)	Slope (ft/ft)	Velocity (ft/sec)	Capacity (cfs)	Description
7.6	25	0.0100	0.05		Sheet Flow, 25' Overland Flow Grass: Dense n= 0.240 P2= 2.14"

Subcatchment 55S: Area Overland to Swales to Dry Pond

Hydrograph

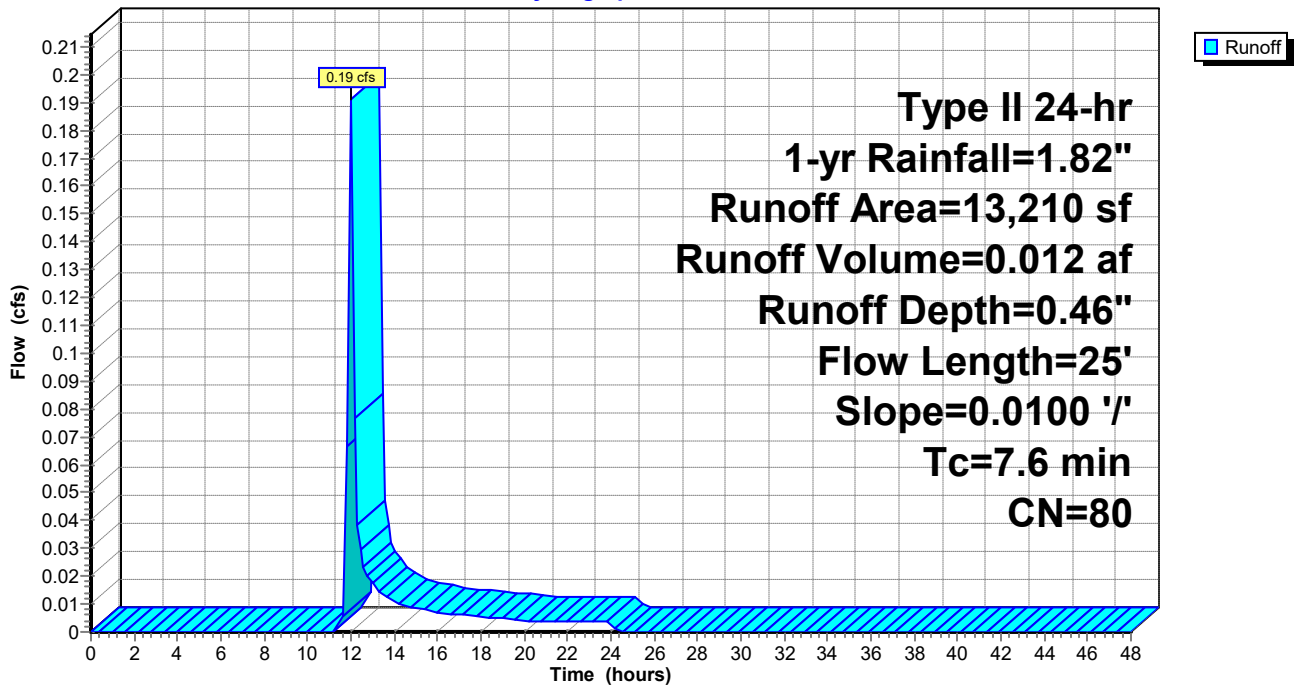

Plug Power - Proposed Conditions 5-15-21

Type II 24-hr 1-yr Rainfall=1.82"

Prepared by {enter your company name here}

Printed 5/20/2021

HydroCAD® 10.10-5a s/n 11585 © 2020 HydroCAD Software Solutions LLC

Page 41

Summary for Subcatchment 56S: Area Overland to Dry Pond

Runoff = 0.28 cfs @ 11.99 hrs, Volume= 0.017 af, Depth= 0.46"

Runoff by SCS TR-20 method, UH=SCS, Weighted-CN, Time Span= 0.00-48.00 hrs, dt= 0.15 hrs
 Type II 24-hr 1-yr Rainfall=1.82"

Area (sf)	CN	Description
19,245	80	>75% Grass cover, Good, HSG D
19,245		100.00% Pervious Area

Tc (min)	Length (feet)	Slope (ft/ft)	Velocity (ft/sec)	Capacity (cfs)	Description
5.0					Direct Entry,

Subcatchment 56S: Area Overland to Dry Pond

Hydrograph

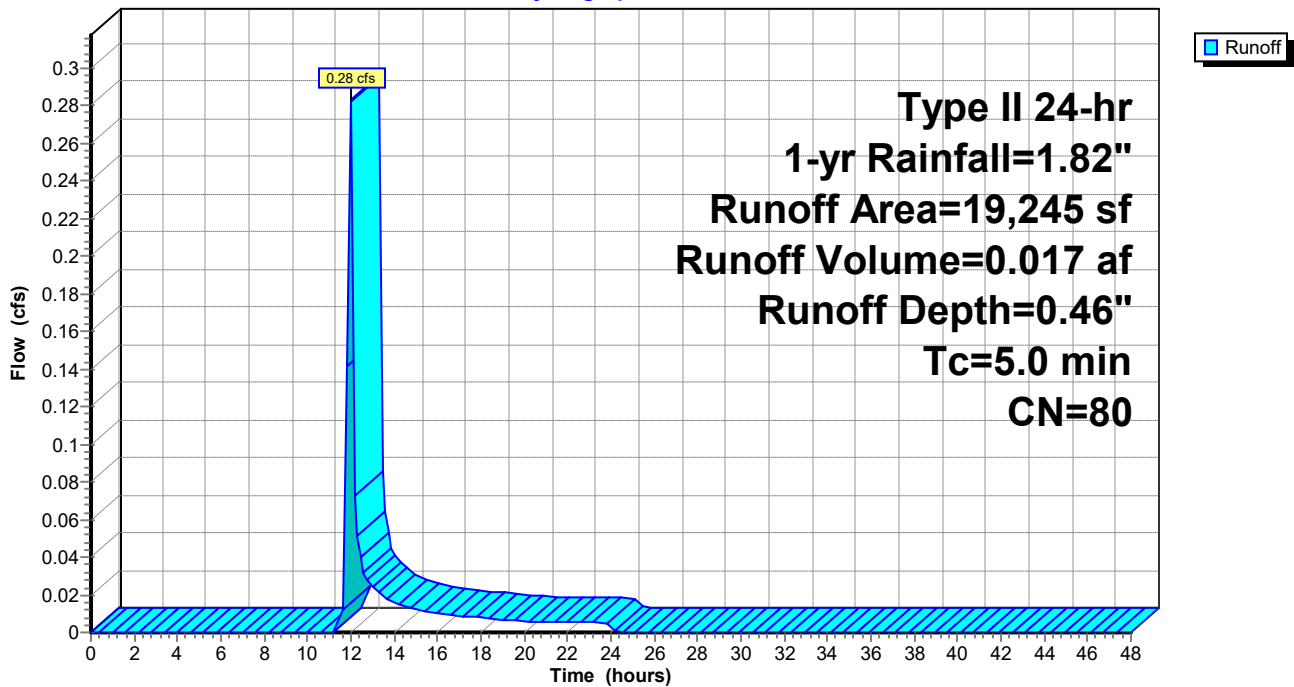

Plug Power - Proposed Conditions 5-15-21

Prepared by {enter your company name here}

HydroCAD® 10.10-5a s/n 11585 © 2020 HydroCAD Software Solutions LLC

Type II 24-hr 1-yr Rainfall=1.82"

Printed 5/20/2021

Page 42

Summary for Subcatchment 57S: Area Overland to North Prop. Line and Wetland Ditch (Central)

Runoff = 0.21 cfs @ 12.04 hrs, Volume= 0.016 af, Depth= 0.36"

Runoff by SCS TR-20 method, UH=SCS, Weighted-CN, Time Span= 0.00-48.00 hrs, dt= 0.15 hrs
Type II 24-hr 1-yr Rainfall=1.82"

Area (sf)	CN	Description
23,585	77	Brush, Fair, HSG D
23,585		100.00% Pervious Area

Tc (min)	Length (feet)	Slope (ft/ft)	Velocity (ft/sec)	Capacity (cfs)	Description
10.6	70	0.0100	0.11		Sheet Flow, 70' Overland Flow Range n= 0.130 P2= 2.14"
0.2	30	0.1000	2.21		Shallow Concentrated Flow, 30' Shallow Conc. Flow Short Grass Pasture Kv= 7.0 fps
10.8	100	Total			

Subcatchment 57S: Area Overland to North Prop. Line and Wetland Ditch (Central)

Hydrograph

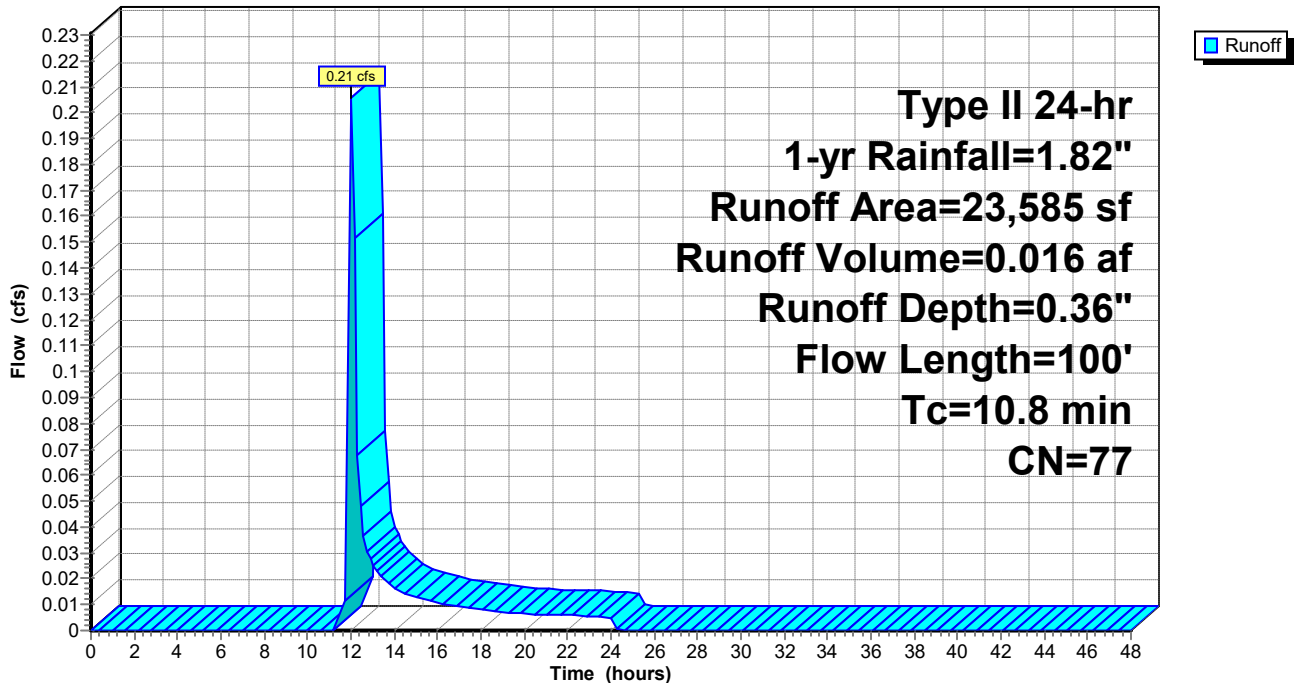

Plug Power - Proposed Conditions 5-15-21

Prepared by {enter your company name here}

HydroCAD® 10.10-5a s/n 11585 © 2020 HydroCAD Software Solutions LLC

Type II 24-hr 1-yr Rainfall=1.82"

Printed 5/20/2021

Page 43

Summary for Subcatchment 58S: Area Overland to North Prop. Line and Wetland Ditch (West)

Runoff = 0.13 cfs @ 12.13 hrs, Volume= 0.012 af, Depth= 0.36"

Runoff by SCS TR-20 method, UH=SCS, Weighted-CN, Time Span= 0.00-48.00 hrs, dt= 0.15 hrs
 Type II 24-hr 1-yr Rainfall=1.82"

Area (sf)	CN	Description
17,005	77	Brush, Fair, HSG D
17,005		100.00% Pervious Area

Tc (min)	Length (feet)	Slope (ft/ft)	Velocity (ft/sec)	Capacity (cfs)	Description
14.1	100	0.0100	0.12		Sheet Flow, 100' Overland Flow Range n= 0.130 P2= 2.14"
0.8	70	0.0400	1.40		Shallow Concentrated Flow, 70' Shallow Conc. Flow Short Grass Pasture Kv= 7.0 fps
14.9	170	Total			

Subcatchment 58S: Area Overland to North Prop. Line and Wetland Ditch (West)

Hydrograph

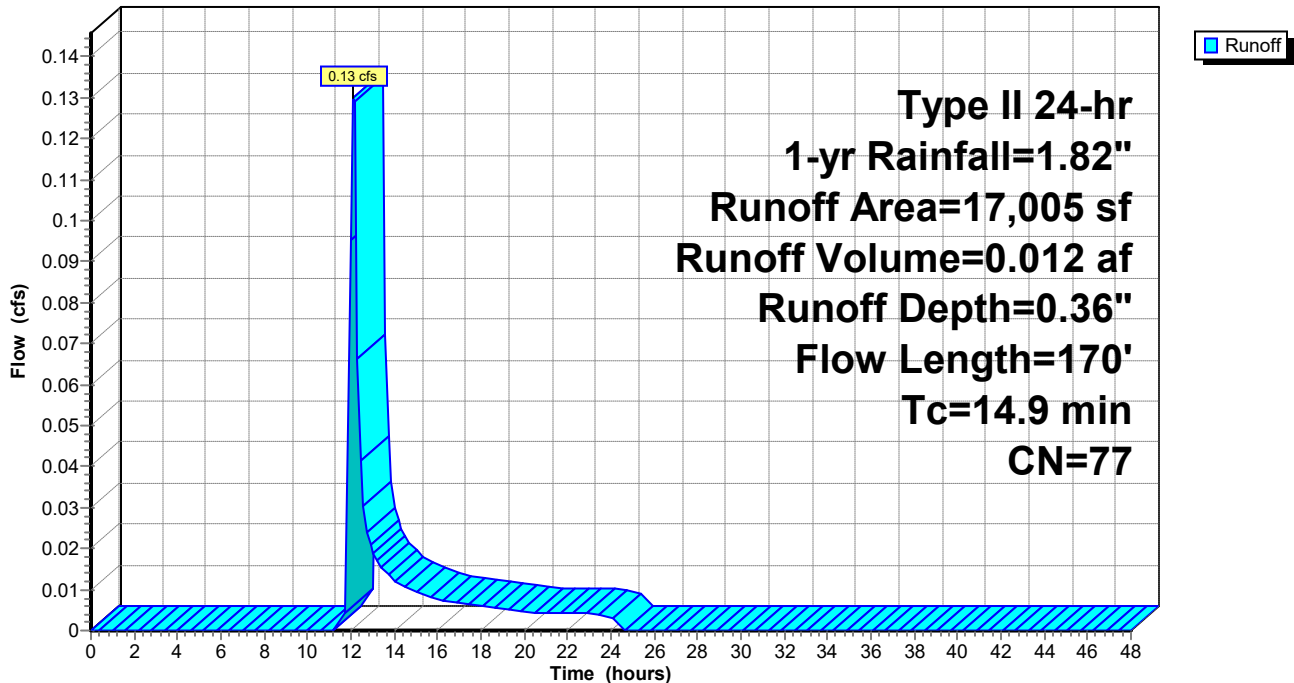

Plug Power - Proposed Conditions 5-15-21

Prepared by {enter your company name here}

HydroCAD® 10.10-5a s/n 11585 © 2020 HydroCAD Software Solutions LLC

Type II 24-hr 1-yr Rainfall=1.82"

Printed 5/20/2021

Page 44

Summary for Reach 7R: Crosby Road Ditch

Inflow Area = 0.230 ac, 0.00% Impervious, Inflow Depth = 0.42" for 1-yr event
Inflow = 0.08 cfs @ 12.20 hrs, Volume= 0.008 af
Outflow = 0.06 cfs @ 12.37 hrs, Volume= 0.008 af, Atten= 24%, Lag= 10.1 min

Routing by Dyn-Stor-Ind method, Time Span= 0.00-48.00 hrs, dt= 0.15 hrs
Max. Velocity= 0.58 fps, Min. Travel Time= 13.0 min
Avg. Velocity = 0.35 fps, Avg. Travel Time= 21.6 min

Peak Storage= 47 cf @ 12.37 hrs
Average Depth at Peak Storage= 0.05', Surface Width= 2.38'
Bank-Full Depth= 2.00' Flow Area= 20.0 sf, Capacity= 98.41 cfs

2.00' x 2.00' deep channel, n= 0.030
Side Slope Z-value= 4.0 '/' Top Width= 18.00'
Length= 450.0' Slope= 0.0089 '/'
Inlet Invert= 673.00', Outlet Invert= 669.00'

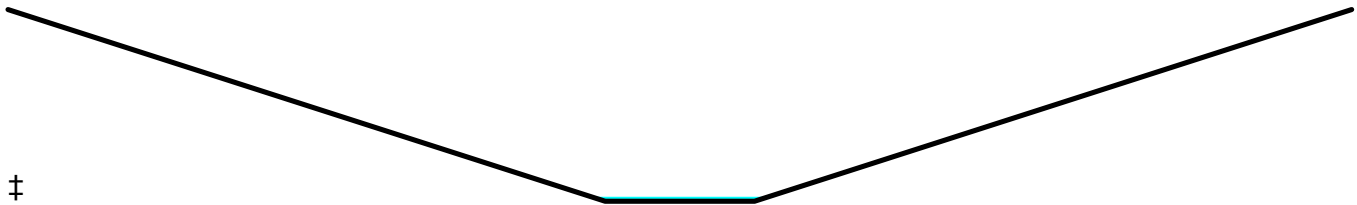

Reach 7R: Crosby Road Ditch

Hydrograph

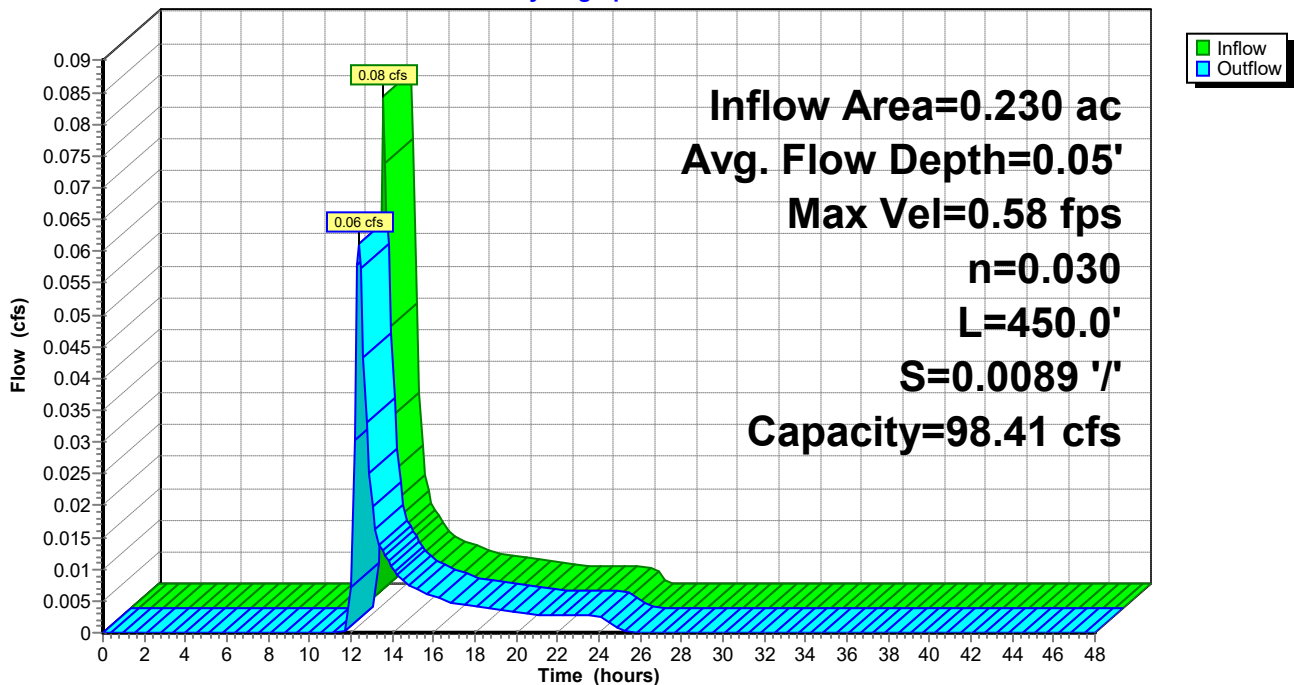

Plug Power - Proposed Conditions 5-15-21

Type II 24-hr 1-yr Rainfall=1.82"

Prepared by {enter your company name here}

Printed 5/20/2021

HydroCAD® 10.10-5a s/n 11585 © 2020 HydroCAD Software Solutions LLC

Page 45

Summary for Reach 9R: North Property Line Ditch (East)

Inflow Area = 1.403 ac, 0.00% Impervious, Inflow Depth = 0.37" for 1-yr event
 Inflow = 0.44 cfs @ 12.07 hrs, Volume= 0.043 af
 Outflow = 0.30 cfs @ 12.24 hrs, Volume= 0.043 af, Atten= 31%, Lag= 10.3 min

Routing by Dyn-Stor-Ind method, Time Span= 0.00-48.00 hrs, dt= 0.15 hrs
 Max. Velocity= 0.91 fps, Min. Travel Time= 12.2 min
 Avg. Velocity = 0.48 fps, Avg. Travel Time= 23.2 min

Peak Storage= 219 cf @ 12.24 hrs
 Average Depth at Peak Storage= 0.11' , Surface Width= 4.12'
 Bank-Full Depth= 3.00' Flow Area= 96.0 sf, Capacity= 634.40 cfs

2.00' x 3.00' deep channel, n= 0.030 Earth, grassed & winding
 Side Slope Z-value= 10.0 ' / ' Top Width= 62.00'
 Length= 670.0' Slope= 0.0100 ' / '
 Inlet Invert= 669.00', Outlet Invert= 662.30'



Reach 9R: North Property Line Ditch (East)

Hydrograph

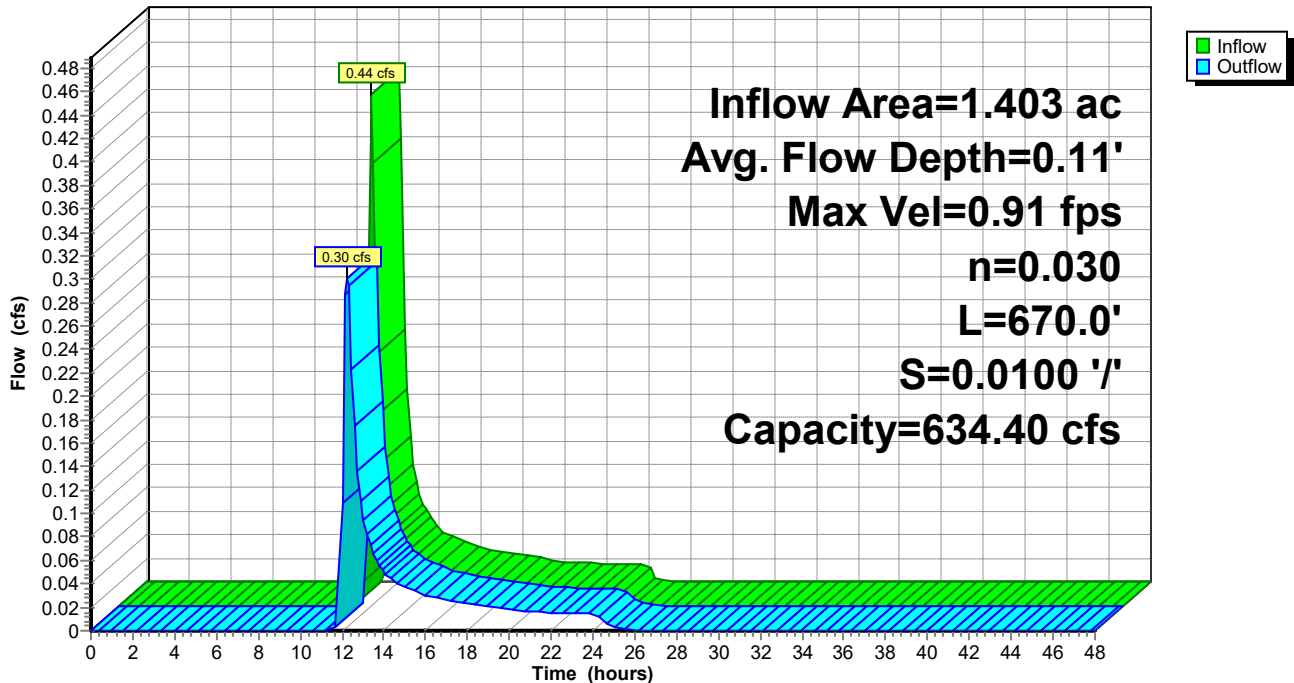

Plug Power - Proposed Conditions 5-15-21

Prepared by {enter your company name here}

HydroCAD® 10.10-5a s/n 11585 © 2020 HydroCAD Software Solutions LLC

Type II 24-hr 1-yr Rainfall=1.82"

Printed 5/20/2021

Page 46

Summary for Reach 23R: North Swale to Bio-Retention Area

Inflow Area = 0.139 ac, 0.00% Impervious, Inflow Depth = 67.33" for 1-yr event
Inflow = 6.61 cfs @ 12.18 hrs, Volume= 0.778 af
Outflow = 6.02 cfs @ 12.31 hrs, Volume= 0.778 af, Atten= 9%, Lag= 7.6 min

Routing by Dyn-Stor-Ind method, Time Span= 0.00-48.00 hrs, dt= 0.15 hrs
Max. Velocity= 0.35 fps, Min. Travel Time= 8.6 min
Avg. Velocity = 0.09 fps, Avg. Travel Time= 32.2 min

Peak Storage= 3,118 cf @ 12.31 hrs
Average Depth at Peak Storage= 1.64' , Surface Width= 17.12'
Bank-Full Depth= 3.00' Flow Area= 48.0 sf, Capacity= 23.67 cfs

4.00' x 3.00' deep channel, n= 0.300
Side Slope Z-value= 4.0 ' / ' Top Width= 28.00'
Length= 180.0' Slope= 0.0050 ' / '
Inlet Invert= 663.90', Outlet Invert= 663.00'



Reach 23R: North Swale to Bio-Retention Area

Hydrograph

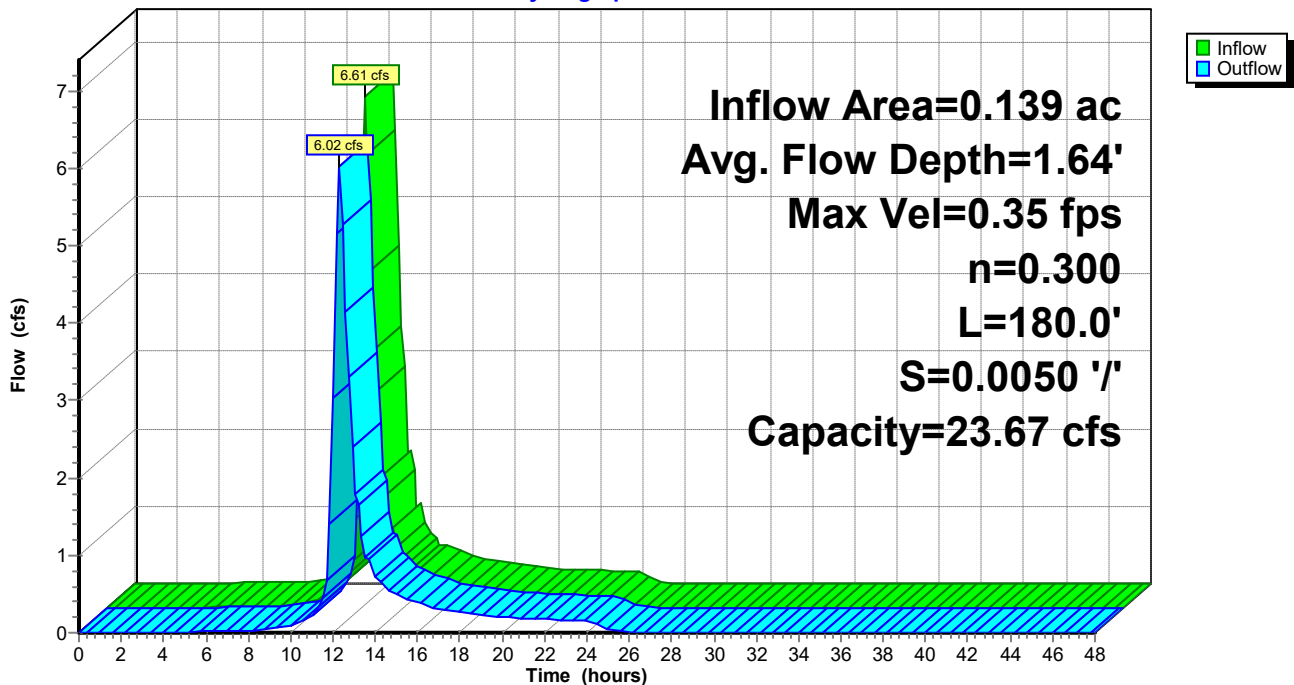

Plug Power - Proposed Conditions 5-15-21

Prepared by {enter your company name here}

HydroCAD® 10.10-5a s/n 11585 © 2020 HydroCAD Software Solutions LLC

Type II 24-hr 1-yr Rainfall=1.82"

Printed 5/20/2021

Page 47

Summary for Reach 25R: North Property Line Ditch (Central0)

Inflow Area = 2.689 ac, 0.00% Impervious, Inflow Depth = 0.39" for 1-yr event
Inflow = 0.57 cfs @ 12.18 hrs, Volume= 0.087 af
Outflow = 0.48 cfs @ 12.36 hrs, Volume= 0.087 af, Atten= 16%, Lag= 10.5 min

Routing by Dyn-Stor-Ind method, Time Span= 0.00-48.00 hrs, dt= 0.15 hrs
Max. Velocity= 0.75 fps, Min. Travel Time= 11.2 min
Avg. Velocity = 0.35 fps, Avg. Travel Time= 23.8 min

Peak Storage= 318 cf @ 12.36 hrs
Average Depth at Peak Storage= 0.17' , Surface Width= 5.42'
Bank-Full Depth= 3.00' Flow Area= 96.0 sf, Capacity= 401.23 cfs

2.00' x 3.00' deep channel, n= 0.030 Earth, grassed & winding
Side Slope Z-value= 10.0 ' / ' Top Width= 62.00'
Length= 500.0' Slope= 0.0040 ' / '
Inlet Invert= 662.30', Outlet Invert= 660.30'

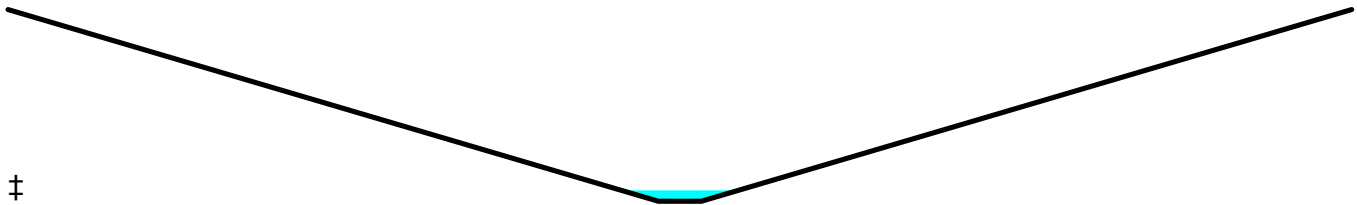

Reach 25R: North Property Line Ditch (Central0)

Hydrograph

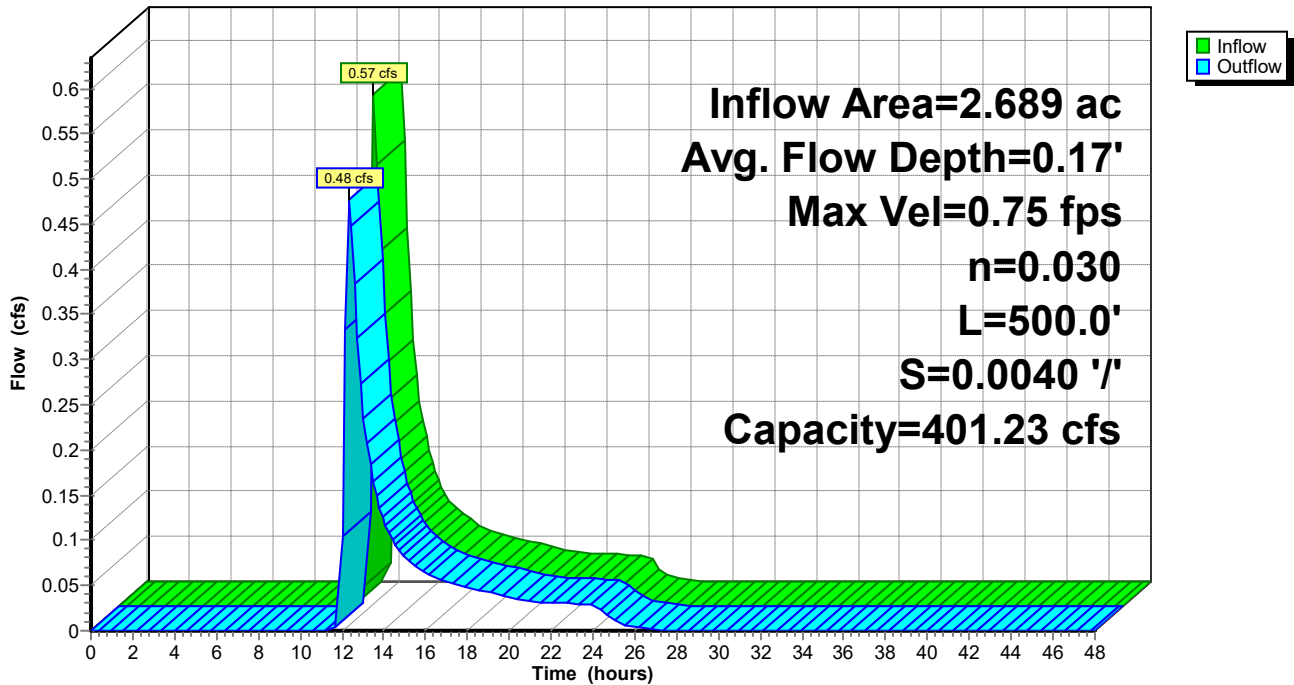

Plug Power - Proposed Conditions 5-15-21

Prepared by {enter your company name here}

HydroCAD® 10.10-5a s/n 11585 © 2020 HydroCAD Software Solutions LLC

Type II 24-hr 1-yr Rainfall=1.82"

Printed 5/20/2021

Page 48

Summary for Reach 26R: North Property Line Ditch (West)

Inflow Area = 27.347 ac, 45.74% Impervious, Inflow Depth = 0.87" for 1-yr event
Inflow = 1.88 cfs @ 12.67 hrs, Volume= 1.972 af
Outflow = 1.75 cfs @ 12.95 hrs, Volume= 1.972 af, Atten= 7%, Lag= 16.4 min

Routing by Dyn-Stor-Ind method, Time Span= 0.00-48.00 hrs, dt= 0.15 hrs
Max. Velocity= 0.88 fps, Min. Travel Time= 9.5 min
Avg. Velocity = 0.57 fps, Avg. Travel Time= 14.6 min

Peak Storage= 1,000 cf @ 12.95 hrs
Average Depth at Peak Storage= 0.36' , Surface Width= 9.16'
Bank-Full Depth= 3.00' Flow Area= 96.0 sf, Capacity= 310.79 cfs

2.00' x 3.00' deep channel, n= 0.030 Earth, grassed & winding
Side Slope Z-value= 10.0 ' / ' Top Width= 62.00'
Length= 500.0' Slope= 0.0024 ' / '
Inlet Invert= 660.30', Outlet Invert= 659.10'

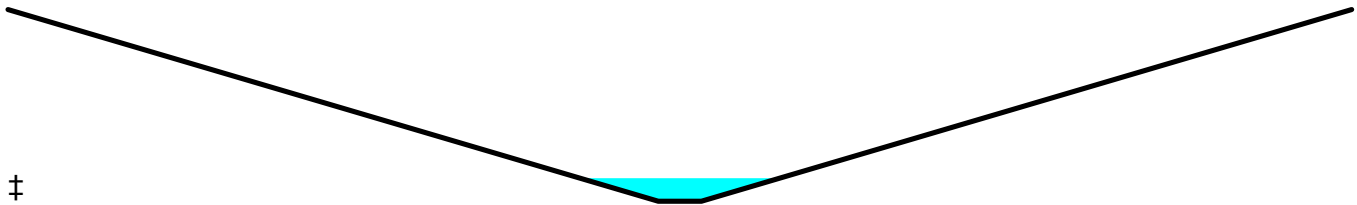

Reach 26R: North Property Line Ditch (West)

Hydrograph

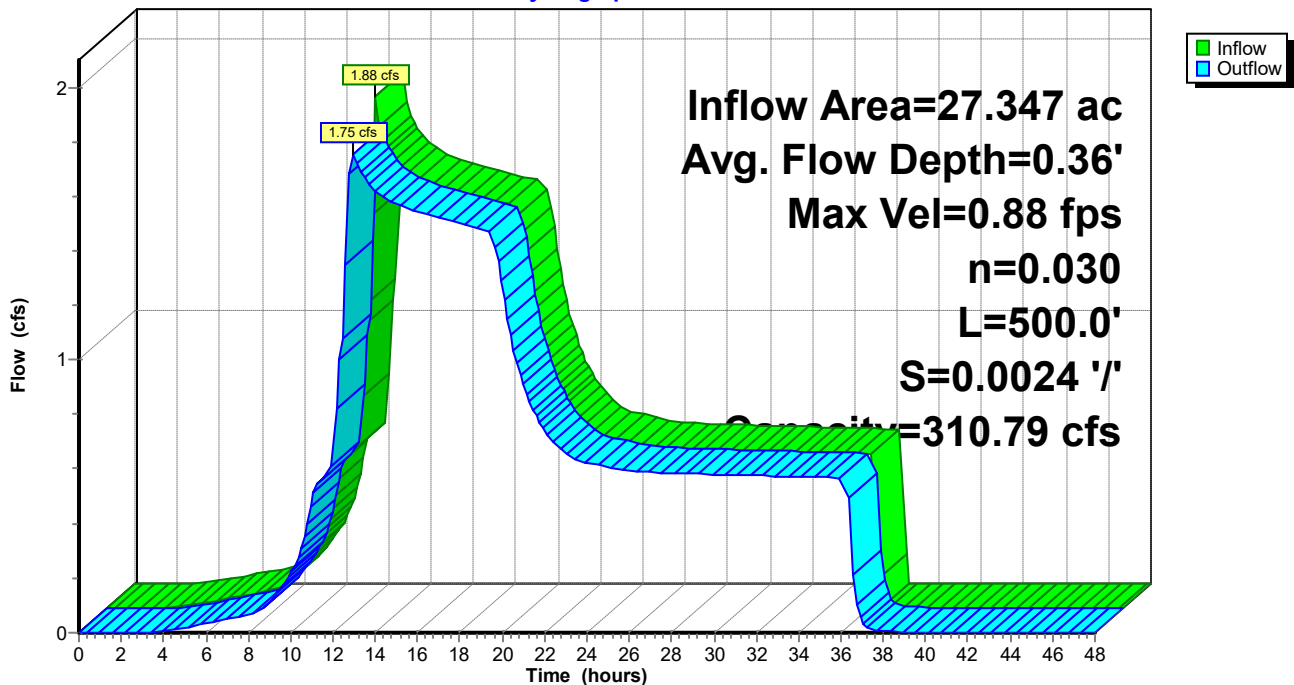

Plug Power - Proposed Conditions 5-15-21

Prepared by {enter your company name here}

HydroCAD® 10.10-5a s/n 11585 © 2020 HydroCAD Software Solutions LLC

Type II 24-hr 1-yr Rainfall=1.82"

Printed 5/20/2021

Page 49

Summary for Reach 27R: Swale to Dry Pond

Inflow Area = 0.303 ac, 0.00% Impervious, Inflow Depth = 0.46" for 1-yr event
Inflow = 0.19 cfs @ 12.00 hrs, Volume= 0.012 af
Outflow = 0.15 cfs @ 12.06 hrs, Volume= 0.012 af, Atten= 20%, Lag= 3.4 min

Routing by Dyn-Stor-Ind method, Time Span= 0.00-48.00 hrs, dt= 0.15 hrs
Max. Velocity= 0.52 fps, Min. Travel Time= 4.1 min
Avg. Velocity = 0.26 fps, Avg. Travel Time= 8.3 min

Peak Storage= 38 cf @ 12.06 hrs
Average Depth at Peak Storage= 0.07' , Surface Width= 4.80'
Bank-Full Depth= 2.00' Flow Area= 32.0 sf, Capacity= 118.87 cfs

A factor of 2.00 has been applied to the storage and discharge capacity
2.00' x 2.00' deep channel, n= 0.030
Side Slope Z-value= 3.0 ' / ' Top Width= 14.00'
Length= 130.0' Slope= 0.0050 ' / '
Inlet Invert= 665.85', Outlet Invert= 665.20'



Reach 27R: Swale to Dry Pond

Hydrograph

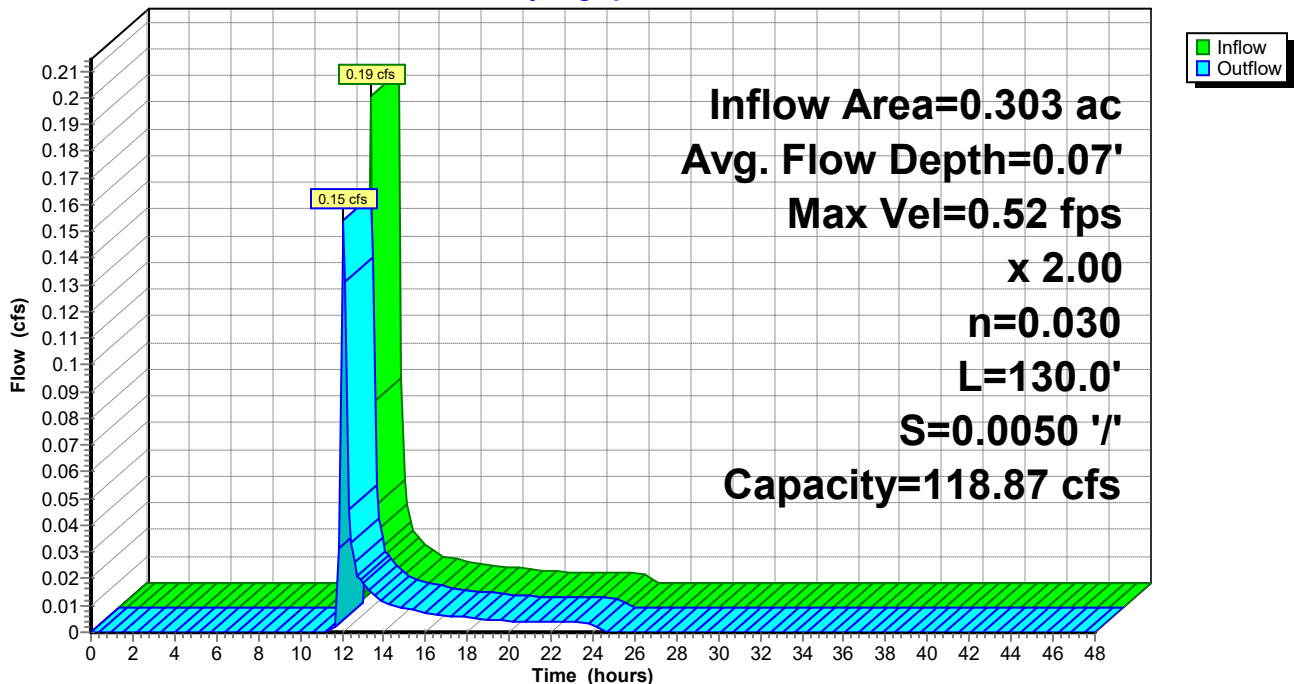

Plug Power - Proposed Conditions 5-15-21

Prepared by {enter your company name here}

HydroCAD® 10.10-5a s/n 11585 © 2020 HydroCAD Software Solutions LLC

Type II 24-hr 1-yr Rainfall=1.82"

Printed 5/20/2021

Page 50

Summary for Reach 52R: West Swale to Bio-Retention Area

Inflow Area = 22.492 ac, 55.62% Impervious, Inflow Depth = 0.55" for 1-yr event
Inflow = 9.25 cfs @ 12.04 hrs, Volume= 1.032 af
Outflow = 8.10 cfs @ 12.18 hrs, Volume= 1.032 af, Atten= 12%, Lag= 8.2 min

Routing by Dyn-Stor-Ind method, Time Span= 0.00-48.00 hrs, dt= 0.15 hrs
Max. Velocity= 0.37 fps, Min. Travel Time= 8.0 min
Avg. Velocity = 0.10 fps, Avg. Travel Time= 29.5 min

Peak Storage= 3,888 cf @ 12.18 hrs
Average Depth at Peak Storage= 1.88' , Surface Width= 19.02'
Bank-Full Depth= 3.00' Flow Area= 48.0 sf, Capacity= 23.67 cfs

4.00' x 3.00' deep channel, n= 0.300
Side Slope Z-value= 4.0 ' / ' Top Width= 28.00'
Length= 180.0' Slope= 0.0050 ' / '
Inlet Invert= 663.90', Outlet Invert= 663.00'



Reach 52R: West Swale to Bio-Retention Area

Hydrograph

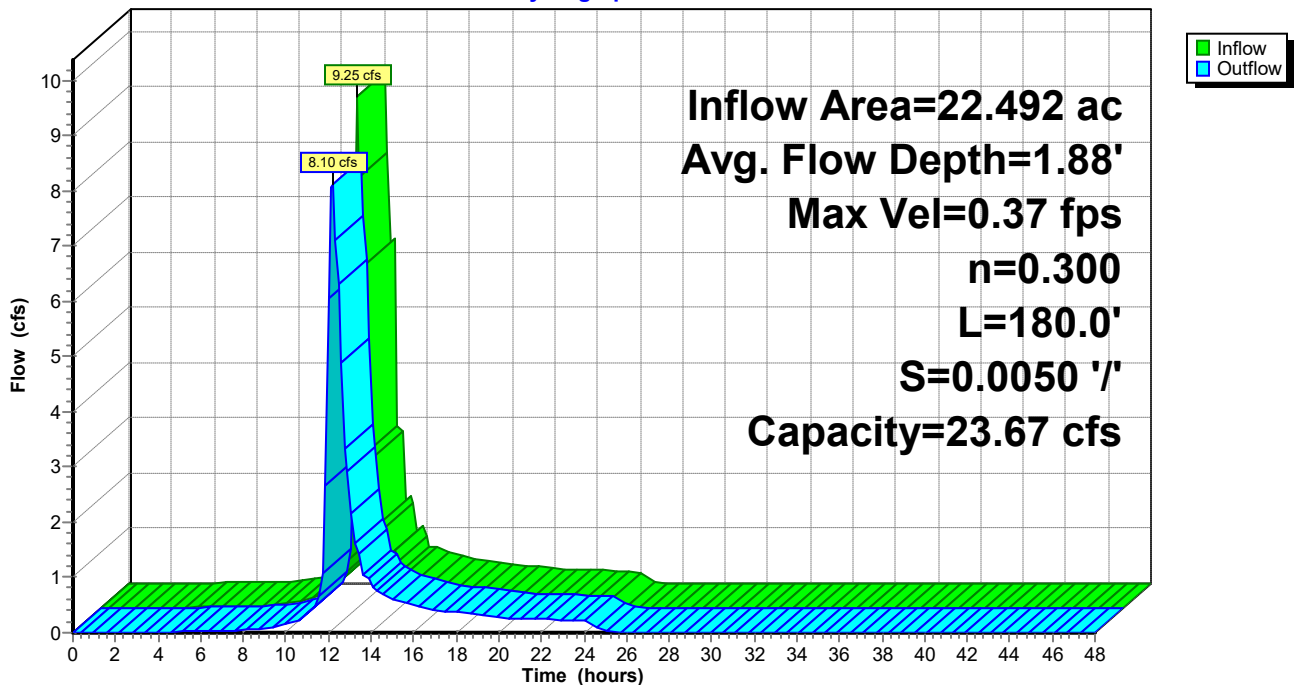

Plug Power - Proposed Conditions 5-15-21

Type II 24-hr 1-yr Rainfall=1.82"

Prepared by {enter your company name here}

Printed 5/20/2021

HydroCAD® 10.10-5a s/n 11585 © 2020 HydroCAD Software Solutions LLC

Page 51

Summary for Pond 11P: CB#1

Inflow Area = 0.442 ac, 67.06% Impervious, Inflow Depth = 1.08" for 1-yr event
 Inflow = 0.58 cfs @ 12.03 hrs, Volume= 0.040 af
 Outflow = 0.58 cfs @ 12.03 hrs, Volume= 0.040 af, Atten= 0%, Lag= 0.0 min
 Primary = 0.58 cfs @ 12.03 hrs, Volume= 0.040 af

Routing by Dyn-Stor-Ind method, Time Span= 0.00-48.00 hrs, dt= 0.15 hrs
 Peak Elev= 667.97' @ 12.11 hrs
 Flood Elev= 672.65'

Device #	Routing	Invert	Outlet Devices
#1	Primary	667.41'	12.0" Round Culvert L= 137.0' CPP, square edge headwall, Ke= 0.500 Inlet / Outlet Invert= 667.41' / 667.14' S= 0.0020 '/' Cc= 0.900 n= 0.012, Flow Area= 0.79 sf

Primary OutFlow Max=0.36 cfs @ 12.03 hrs HW=667.94' TW=667.79' (Dynamic Tailwater)
 ↑1=Culvert (Outlet Controls 0.36 cfs @ 1.25 fps)

Pond 11P: CB#1

Hydrograph

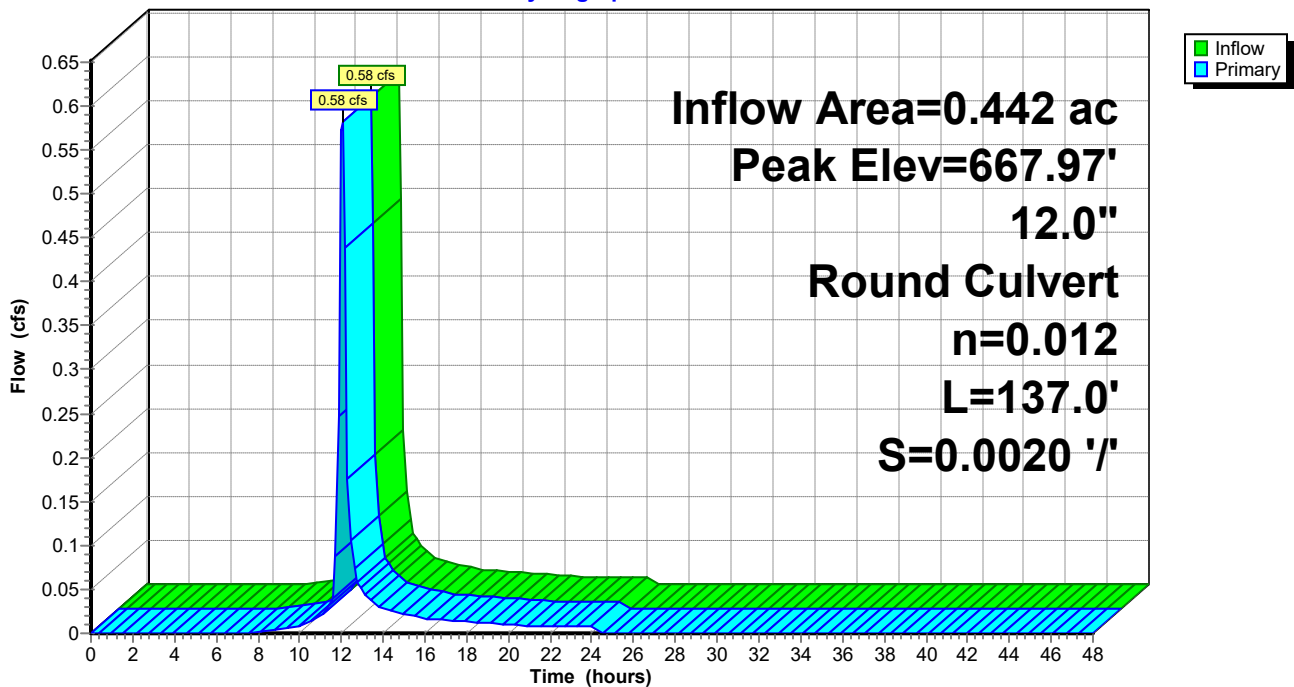

Plug Power - Proposed Conditions 5-15-21

Prepared by {enter your company name here}

HydroCAD® 10.10-5a s/n 11585 © 2020 HydroCAD Software Solutions LLC

Type II 24-hr 1-yr Rainfall=1.82"

Printed 5/20/2021

Page 52

Summary for Pond 13P: CB#3

Inflow Area = 0.724 ac, 59.47% Impervious, Inflow Depth = 1.00" for 1-yr event
Inflow = 0.88 cfs @ 12.03 hrs, Volume= 0.060 af
Outflow = 0.88 cfs @ 12.03 hrs, Volume= 0.060 af, Atten= 0%, Lag= 0.0 min
Primary = 0.88 cfs @ 12.03 hrs, Volume= 0.060 af

Routing by Dyn-Stor-Ind method, Time Span= 0.00-48.00 hrs, dt= 0.15 hrs

Peak Elev= 667.81' @ 12.09 hrs

Flood Elev= 672.65'

Device	Routing	Invert	Outlet Devices
#1	Primary	667.14'	12.0" Round Culvert L= 213.0' CPP, square edge headwall, Ke= 0.500 Inlet / Outlet Invert= 667.14' / 666.71' S= 0.0020 '/ Cc= 0.900 n= 0.012, Flow Area= 0.79 sf

Primary OutFlow Max=0.61 cfs @ 12.03 hrs HW=667.79' TW=667.50' (Dynamic Tailwater)
↑1=Culvert (Outlet Controls 0.61 cfs @ 1.61 fps)

Pond 13P: CB#3

Hydrograph

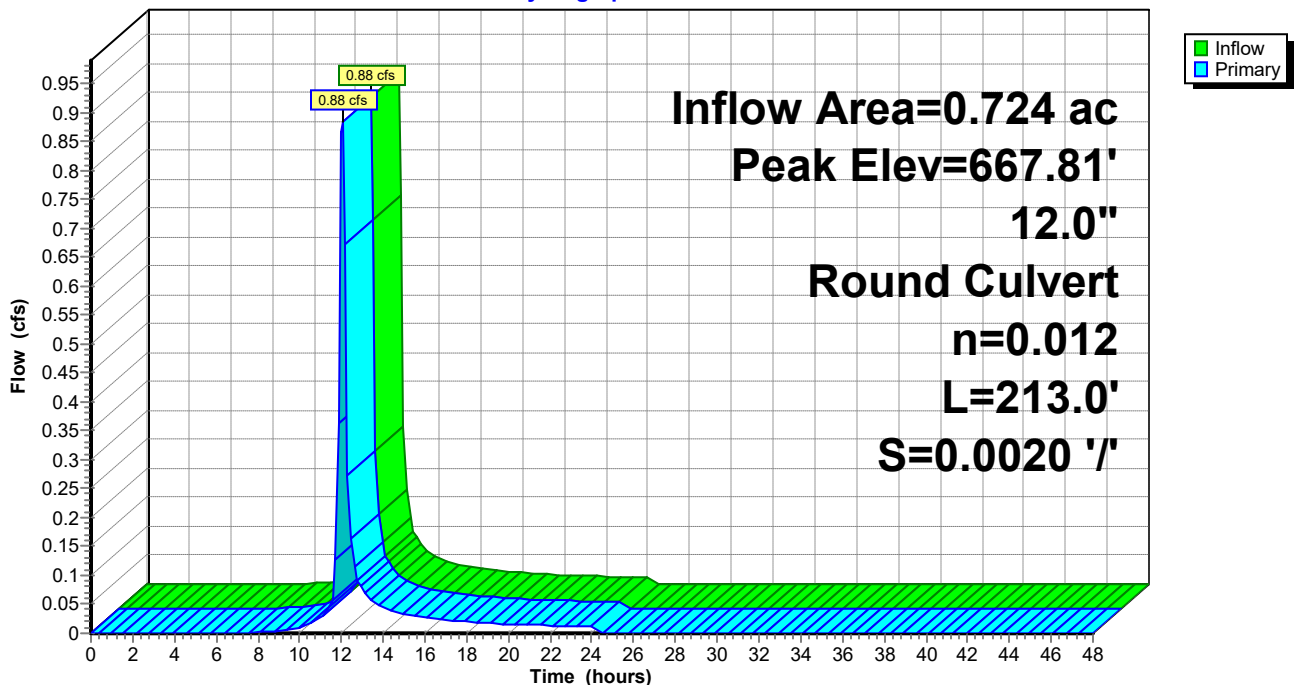

Plug Power - Proposed Conditions 5-15-21

Prepared by {enter your company name here}

HydroCAD® 10.10-5a s/n 11585 © 2020 HydroCAD Software Solutions LLC

Type II 24-hr 1-yr Rainfall=1.82"

Printed 5/20/2021

Page 53

Summary for Pond 15P: CB#5

Inflow Area = 3.805 ac, 39.15% Impervious, Inflow Depth = 0.77" for 1-yr event
Inflow = 2.68 cfs @ 12.15 hrs, Volume= 0.243 af
Outflow = 2.68 cfs @ 12.15 hrs, Volume= 0.243 af, Atten= 0%, Lag= 0.0 min
Primary = 2.68 cfs @ 12.15 hrs, Volume= 0.243 af

Routing by Dyn-Stor-Ind method, Time Span= 0.00-48.00 hrs, dt= 0.15 hrs

Peak Elev= 667.60' @ 12.15 hrs

Flood Elev= 670.95'

Device	Routing	Invert	Outlet Devices
#1	Primary	666.71'	24.0" Round Culvert L= 180.0' CPP, square edge headwall, Ke= 0.500 Inlet / Outlet Invert= 666.71' / 666.35' S= 0.0020 '/ Cc= 0.900 n= 0.012, Flow Area= 3.14 sf

Primary OutFlow Max=2.67 cfs @ 12.15 hrs HW=667.59' TW=665.75' (Dynamic Tailwater)
↑1=Culvert (Barrel Controls 2.67 cfs @ 2.93 fps)

Pond 15P: CB#5

Hydrograph

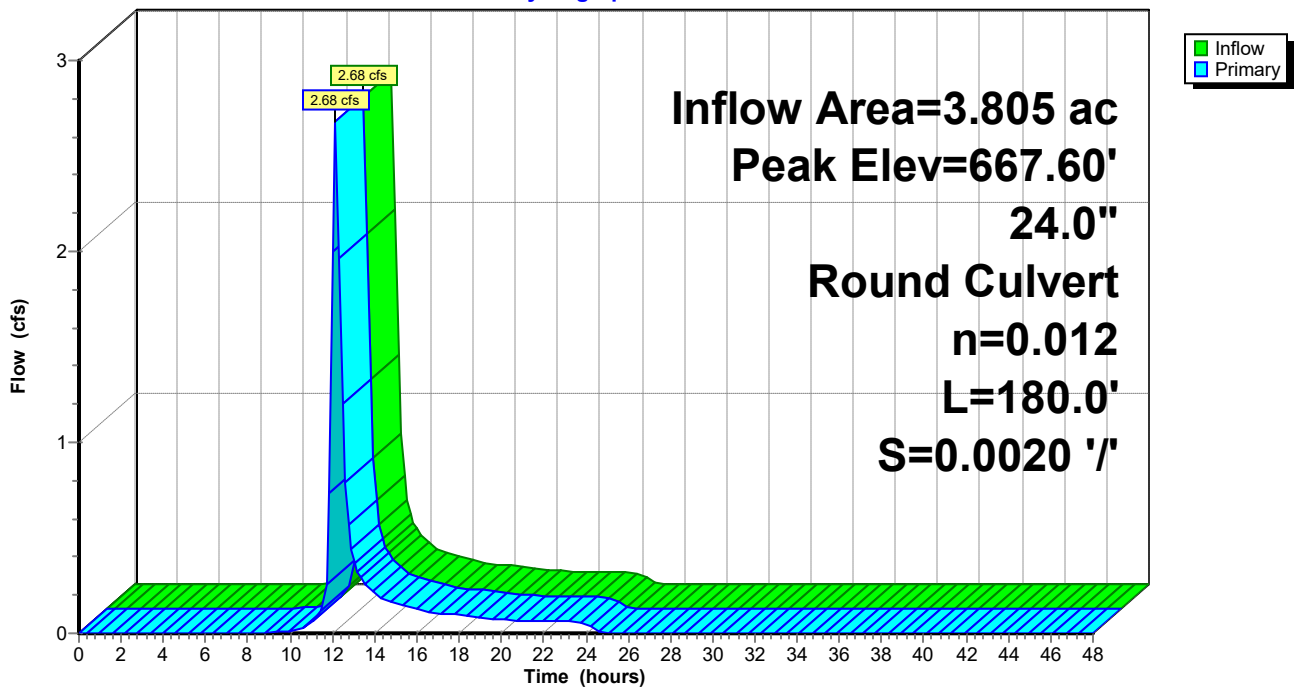

Plug Power - Proposed Conditions 5-15-21

Type II 24-hr 1-yr Rainfall=1.82"

Prepared by {enter your company name here}

Printed 5/20/2021

HydroCAD® 10.10-5a s/n 11585 © 2020 HydroCAD Software Solutions LLC

Page 54

Summary for Pond 19P: YD#22

Inflow Area = 0.624 ac, 27.67% Impervious, Inflow Depth = 0.53" for 1-yr event
Inflow = 0.30 cfs @ 12.19 hrs, Volume= 0.028 af
Outflow = 0.30 cfs @ 12.19 hrs, Volume= 0.028 af, Atten= 0%, Lag= 0.1 min
Primary = 0.30 cfs @ 12.19 hrs, Volume= 0.028 af

Routing by Dyn-Stor-Ind method, Time Span= 0.00-48.00 hrs, dt= 0.15 hrs
Peak Elev= 666.46' @ 12.14 hrs Surf.Area= 1 sf Storage= 1 cf
Flood Elev= 669.45' Surf.Area= 17,680 sf Storage= 5,217 cf

Plug-Flow detention time= (not calculated: outflow precedes inflow)
Center-of-Mass det. time= 0.1 min (881.2 - 881.1)

Volume	Invert	Avail.Storage	Storage Description
#1	665.26'	5,217 cf	Custom Stage Data (Prismatic) Listed below (Recalc)

Elevation (feet)	Surf.Area (sq-ft)	Inc.Store (cubic-feet)	Cum.Store (cubic-feet)
665.26	1	0	0
668.55	1	3	3
669.00	2,745	618	621
669.45	17,680	4,596	5,217

Device	Routing	Invert	Outlet Devices
#1	Primary	665.26'	10.0" Round Culvert L= 70.0' CPP, square edge headwall, Ke= 0.500 Inlet / Outlet Invert= 665.26' / 665.12' S= 0.0020 '/' Cc= 0.900 n= 0.012, Flow Area= 0.55 sf

Primary OutFlow Max=1.24 cfs @ 12.19 hrs HW=666.36' TW=666.06' (Dynamic Tailwater)
↑**1=Culvert** (Outlet Controls 1.24 cfs @ 2.28 fps)

Plug Power - Proposed Conditions 5-15-21

Prepared by {enter your company name here}

HydroCAD® 10.10-5a s/n 11585 © 2020 HydroCAD Software Solutions LLC

Type II 24-hr 1-yr Rainfall=1.82"

Printed 5/20/2021

Page 55

Pond 19P: YD#22

Hydrograph

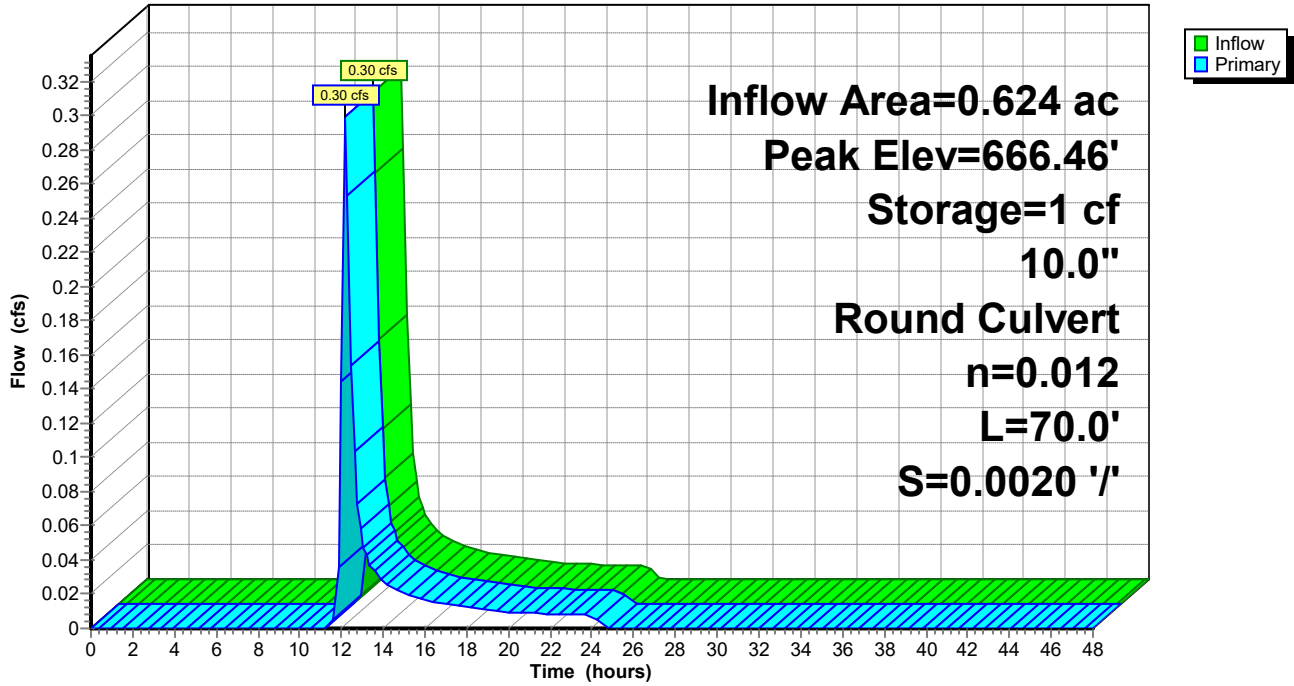

Plug Power - Proposed Conditions 5-15-21

Type II 24-hr 1-yr Rainfall=1.82"

Prepared by {enter your company name here}

Printed 5/20/2021

HydroCAD® 10.10-5a s/n 11585 © 2020 HydroCAD Software Solutions LLC

Page 56

Summary for Pond 21P: Subsurface Detention within Gravel Area

Inflow Area = 22.356 ac, 55.95% Impervious, Inflow Depth = 0.97" for 1-yr event
 Inflow = 17.37 cfs @ 12.06 hrs, Volume= 1.800 af
 Outflow = 14.47 cfs @ 12.10 hrs, Volume= 1.800 af, Atten= 17%, Lag= 2.6 min
 Primary = 9.17 cfs @ 12.04 hrs, Volume= 1.027 af
 Secondary = 6.59 cfs @ 12.18 hrs, Volume= 0.773 af
 Tertiary = 0.00 cfs @ 0.00 hrs, Volume= 0.000 af

Routing by Dyn-Stor-Ind method, Time Span= 0.00-48.00 hrs, dt= 0.15 hrs
 Peak Elev= 665.90' @ 12.32 hrs Surf.Area= 5,992 sf Storage= 3,785 cf
 Flood Elev= 668.95' Surf.Area= 129,465 sf Storage= 49,282 cf

Plug-Flow detention time= 4.0 min calculated for 1.794 af (100% of inflow)
 Center-of-Mass det. time= 4.0 min (834.6 - 830.6)

Volume	Invert	Avail.Storage	Storage Description
#1	664.01'	9,879 cf	Custom Stage Data (Prismatic) Listed below (Recalc) 30,436 cf Overall - 5,739 cf Embedded = 24,697 cf x 40.0% Voids
#2	664.01'	126 cf	24.0" Round Pipe Storage Inside #1 L= 40.0'
#3	664.01'	3,657 cf	24.0" Round Pipe Storage Inside #1 L= 1,164.0' S= 0.0020 '/'
#4	664.01'	1,421 cf	18.0" Round Pipe Storage Inside #1 L= 804.0' S= 0.0020 '/'
#5	665.61'	209 cf	15.0" Round Pipe Storage Inside #1 L= 170.0' S= 0.0020 '/'
#6	665.95'	202 cf	12.0" Round Pipe Storage Inside #1 L= 257.0' S= 0.0020 '/'
#7	666.46'	38 cf	10.0" Round Pipe Storage Inside #1 L= 69.0' S= 0.0020 '/'
#8	666.35'	88 cf	10.0" Round Pipe Storage Inside #1 L= 161.0' S= 0.0020 '/'
#9	668.02'	33,664 cf	Custom Stage Data (Prismatic) Listed below (Recalc) 84,161 cf Overall x 40.0% Voids
		49,282 cf	Total Available Storage

Elevation (feet)	Surf.Area (sq-ft)	Inc.Store (cubic-feet)	Cum.Store (cubic-feet)
664.01	3	0	0
666.67	8,430	11,216	11,216
668.95	8,430	19,220	30,436

Elevation (feet)	Surf.Area (sq-ft)	Inc.Store (cubic-feet)	Cum.Store (cubic-feet)
668.02	0	0	0
668.18	33,970	2,718	2,718
668.45	121,035	20,926	23,643
668.95	121,035	60,518	84,161

Plug Power - Proposed Conditions 5-15-21

Type II 24-hr 1-yr Rainfall=1.82"

Prepared by {enter your company name here}

Printed 5/20/2021

HydroCAD® 10.10-5a s/n 11585 © 2020 HydroCAD Software Solutions LLC

Page 57

Device	Routing	Invert	Outlet Devices
#1	Primary	664.01'	18.0" Round Culvert X 2.00 L= 57.0' CPP, square edge headwall, Ke= 0.500 Inlet / Outlet Invert= 664.01' / 663.90' S= 0.0019' /' Cc= 0.900 n= 0.012, Flow Area= 1.77 sf
#2	Secondary	664.01'	18.0" Round Culvert L= 57.0' CPP, square edge headwall, Ke= 0.500 Inlet / Outlet Invert= 664.01' / 663.90' S= 0.0019' /' Cc= 0.900 n= 0.012, Flow Area= 1.77 sf
#3	Tertiary	665.95'	18.0" Round Culvert X 3.00 L= 50.0' CPP, square edge headwall, Ke= 0.500 Inlet / Outlet Invert= 665.95' / 665.85' S= 0.0020' /' Cc= 0.900 n= 0.012, Flow Area= 1.77 sf

Primary OutFlow Max=0.00 cfs @ 12.04 hrs HW=665.51' TW=665.61' (Dynamic Tailwater)
 ↳1=Culvert (Controls 0.00 cfs)

Secondary OutFlow Max=4.90 cfs @ 12.18 hrs HW=665.78' TW=665.45' (Dynamic Tailwater)
 ↳2=Culvert (Inlet Controls 4.90 cfs @ 2.78 fps)

Tertiary OutFlow Max=0.00 cfs @ 0.00 hrs HW=664.01' TW=665.85' (Dynamic Tailwater)
 ↳3=Culvert (Controls 0.00 cfs)

Pond 21P: Subsurface Detention within Gravel Area

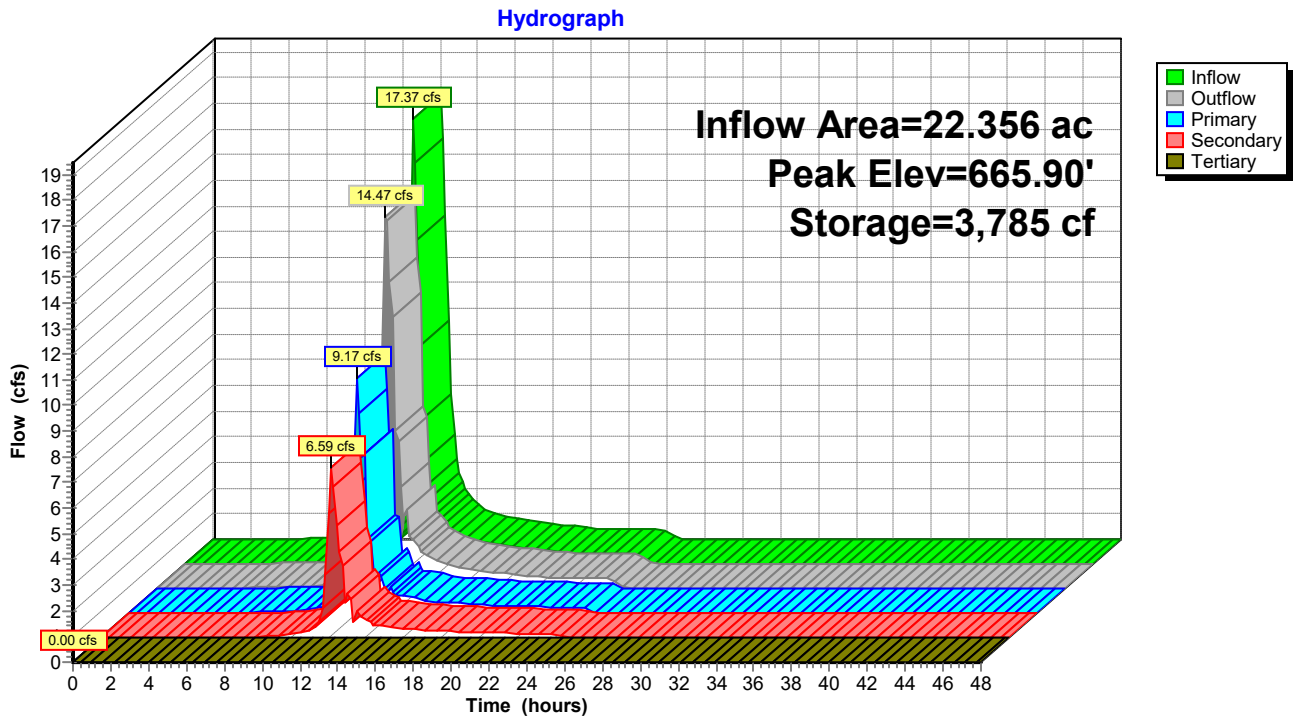

Plug Power - Proposed Conditions 5-15-21

Type II 24-hr 1-yr Rainfall=1.82"

Prepared by {enter your company name here}

Printed 5/20/2021

HydroCAD® 10.10-5a s/n 11585 © 2020 HydroCAD Software Solutions LLC

Page 58

Summary for Pond 22P: Bio-Retention Area

Inflow Area = 24.268 ac, 51.54% Impervious, Inflow Depth = 0.93" for 1-yr event
 Inflow = 13.85 cfs @ 12.22 hrs, Volume= 1.873 af
 Outflow = 1.48 cfs @ 14.25 hrs, Volume= 1.873 af, Atten= 89%, Lag= 122.0 min
 Primary = 1.48 cfs @ 14.25 hrs, Volume= 1.873 af
 Secondary = 0.00 cfs @ 0.00 hrs, Volume= 0.000 af

Routing by Dyn-Stor-Ind method, Time Span= 0.00-48.00 hrs, dt= 0.15 hrs
 Peak Elev= 663.82' @ 14.25 hrs Surf.Area= 54,347 sf Storage= 42,072 cf

Plug-Flow detention time= (not calculated: outflow precedes inflow)
 Center-of-Mass det. time= 407.4 min (1,256.9 - 849.6)

Volume	Invert	Avail.Storage	Storage Description
#1	663.00'	95,677 cf	Custom Stage Data (Prismatic) Listed below (Recalc)
Elevation (feet)	Surf.Area (sq-ft)	Inc.Store (cubic-feet)	Cum.Store (cubic-feet)
663.00	48,935	0	0
663.25	50,025	12,370	12,370
663.50	51,115	12,643	25,013
664.00	56,110	26,806	51,819
664.75	60,845	43,858	95,677

Device	Routing	Invert	Outlet Devices
#1	Primary	660.55'	15.0" Round Culvert L= 25.0' CPP, square edge headwall, Ke= 0.500 Inlet / Outlet Invert= 660.55' / 660.50' S= 0.0020 '/' Cc= 0.900 n= 0.012, Flow Area= 1.23 sf
#2	Primary	660.55'	15.0" Round Culvert L= 25.0' CPP, square edge headwall, Ke= 0.500 Inlet / Outlet Invert= 660.55' / 660.50' S= 0.0020 '/' Cc= 0.900 n= 0.012, Flow Area= 1.23 sf
#3	Device 1	660.56'	4.0" Round Culvert L= 5.0' CPP, square edge headwall, Ke= 0.500 Inlet / Outlet Invert= 660.56' / 660.55' S= 0.0020 '/' Cc= 0.900 n= 0.012, Flow Area= 0.09 sf
#4	Device 2	660.56'	4.0" Round Culvert L= 5.0' CPP, square edge headwall, Ke= 0.500 Inlet / Outlet Invert= 660.56' / 660.55' S= 0.0020 '/' Cc= 0.900 n= 0.012, Flow Area= 0.09 sf
#5	Device 3	663.00'	0.500 in/hr Exfiltration X 0.50 over Surface area
#6	Device 4	663.00'	0.500 in/hr Exfiltration X 0.50 over Surface area
#7	Device 3	663.50'	4.0" Horiz. Orifice/Grate X 4.00 C= 0.600 Limited to weir flow at low heads
#8	Device 4	663.50'	4.0" Horiz. Orifice/Grate X 3.00 C= 0.600 Limited to weir flow at low heads
#9	Device 1	664.25'	1.4" x 4.5" Horiz. Orifice/Grate X 72.00 C= 0.600 Limited to weir flow at low heads
#10	Device 2	664.25'	1.4" x 4.5" Horiz. Orifice/Grate X 72.00 C= 0.600 Limited to weir flow at low heads
#11	Secondary	664.50'	100.0' long x 2.0' breadth Broad-Crested Rectangular Weir

Plug Power - Proposed Conditions 5-15-21

Type II 24-hr 1-yr Rainfall=1.82"

Prepared by {enter your company name here}

Printed 5/20/2021

HydroCAD® 10.10-5a s/n 11585 © 2020 HydroCAD Software Solutions LLC

Page 59

Head (feet)	0.20	0.40	0.60	0.80	1.00	1.20	1.40	1.60	1.80	2.00
	2.50	3.00	3.50							
Coef. (English)	2.54	2.61	2.61	2.60	2.66	2.70	2.77	2.89	2.88	
	2.85	3.07	3.20	3.32						

Primary OutFlow Max=1.48 cfs @ 14.25 hrs HW=663.82' TW=660.64' (Dynamic Tailwater)

- 1=Culvert (Passes 0.74 cfs of 9.62 cfs potential flow)
- 3=Culvert (Inlet Controls 0.74 cfs @ 8.47 fps)
- 5=Exfiltration (Passes < 0.31 cfs potential flow)
- 7=Orifice/Grate (Passes < 0.96 cfs potential flow)
- 9=Orifice/Grate (Controls 0.00 cfs)
- 2=Culvert (Passes 0.74 cfs of 9.62 cfs potential flow)
- 4=Culvert (Inlet Controls 0.74 cfs @ 8.47 fps)
- 6=Exfiltration (Passes < 0.31 cfs potential flow)
- 8=Orifice/Grate (Passes < 0.72 cfs potential flow)
- 10=Orifice/Grate (Controls 0.00 cfs)

Secondary OutFlow Max=0.00 cfs @ 0.00 hrs HW=663.00' TW=660.30' (Dynamic Tailwater)

- 11=Broad-Crested Rectangular Weir (Controls 0.00 cfs)

Pond 22P: Bio-Retention Area

Hydrograph

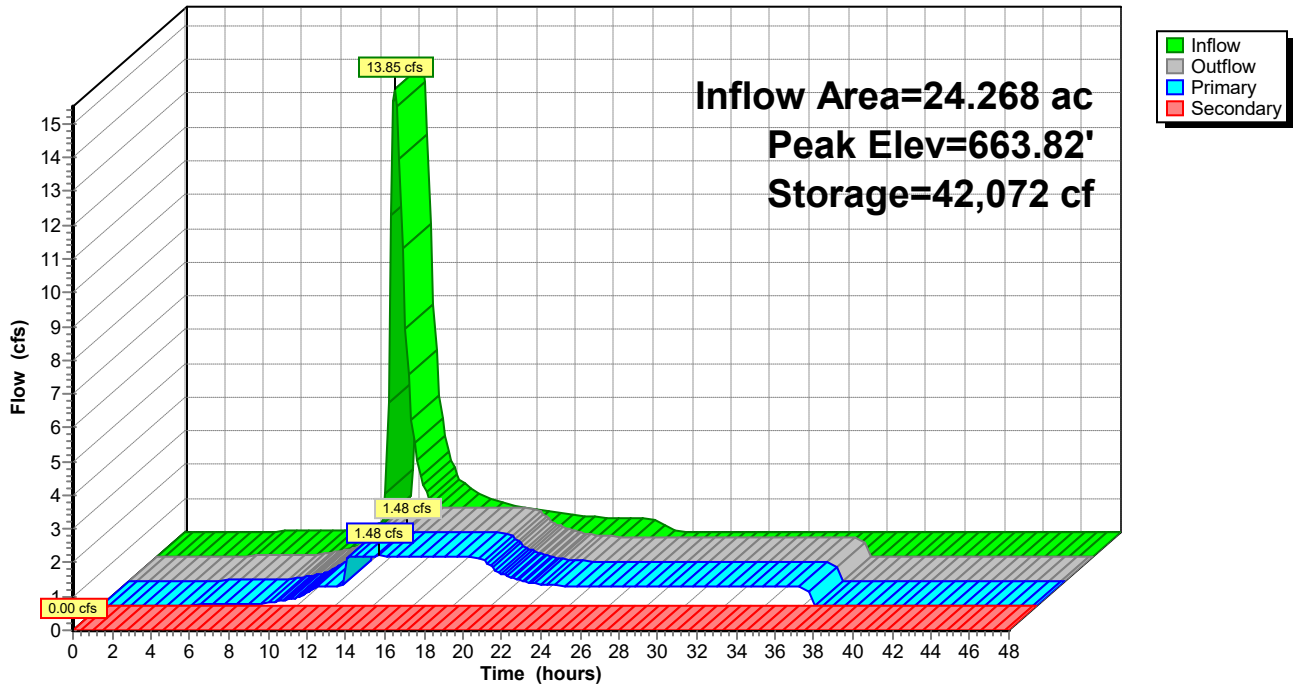

Plug Power - Proposed Conditions 5-15-21

Type II 24-hr 1-yr Rainfall=1.82"

Prepared by {enter your company name here}

Printed 5/20/2021

HydroCAD® 10.10-5a s/n 11585 © 2020 HydroCAD Software Solutions LLC

Page 60

Summary for Pond 25P: YD#11

Inflow Area = 0.893 ac, 53.89% Impervious, Inflow Depth = 0.94" for 1-yr event
 Inflow = 0.92 cfs @ 12.11 hrs, Volume= 0.070 af
 Outflow = 0.92 cfs @ 12.12 hrs, Volume= 0.070 af, Atten= 0%, Lag= 0.0 min
 Primary = 0.92 cfs @ 12.12 hrs, Volume= 0.070 af

Routing by Dyn-Stor-Ind method, Time Span= 0.00-48.00 hrs, dt= 0.15 hrs
 Peak Elev= 667.10' @ 12.18 hrs Surf.Area= 1 sf Storage= 1 cf
 Flood Elev= 669.70' Surf.Area= 3,725 sf Storage= 1,028 cf

Plug-Flow detention time= 0.0 min calculated for 0.070 af (100% of inflow)
 Center-of-Mass det. time= 0.0 min (838.1 - 838.0)

Volume	Invert	Avail.Storage	Storage Description
#1	666.25'	1,028 cf	Custom Stage Data (Prismatic) Listed below (Recalc)

Elevation (feet)	Surf.Area (sq-ft)	Inc.Store (cubic-feet)	Cum.Store (cubic-feet)
666.25	1	0	0
669.15	1	3	3
669.70	3,725	1,025	1,028

Device	Routing	Invert	Outlet Devices
#1	Primary	666.25'	12.0" Round Culvert L= 170.0' CPP, square edge headwall, Ke= 0.500 Inlet / Outlet Invert= 666.25' / 665.91' S= 0.0020 '/' Cc= 0.900 n= 0.012, Flow Area= 0.79 sf

Primary OutFlow Max=0.63 cfs @ 12.12 hrs HW=667.05' TW=666.91' (Dynamic Tailwater)
 ↑**1=Culvert** (Outlet Controls 0.63 cfs @ 1.28 fps)

Pond 25P: YD#11

Hydrograph

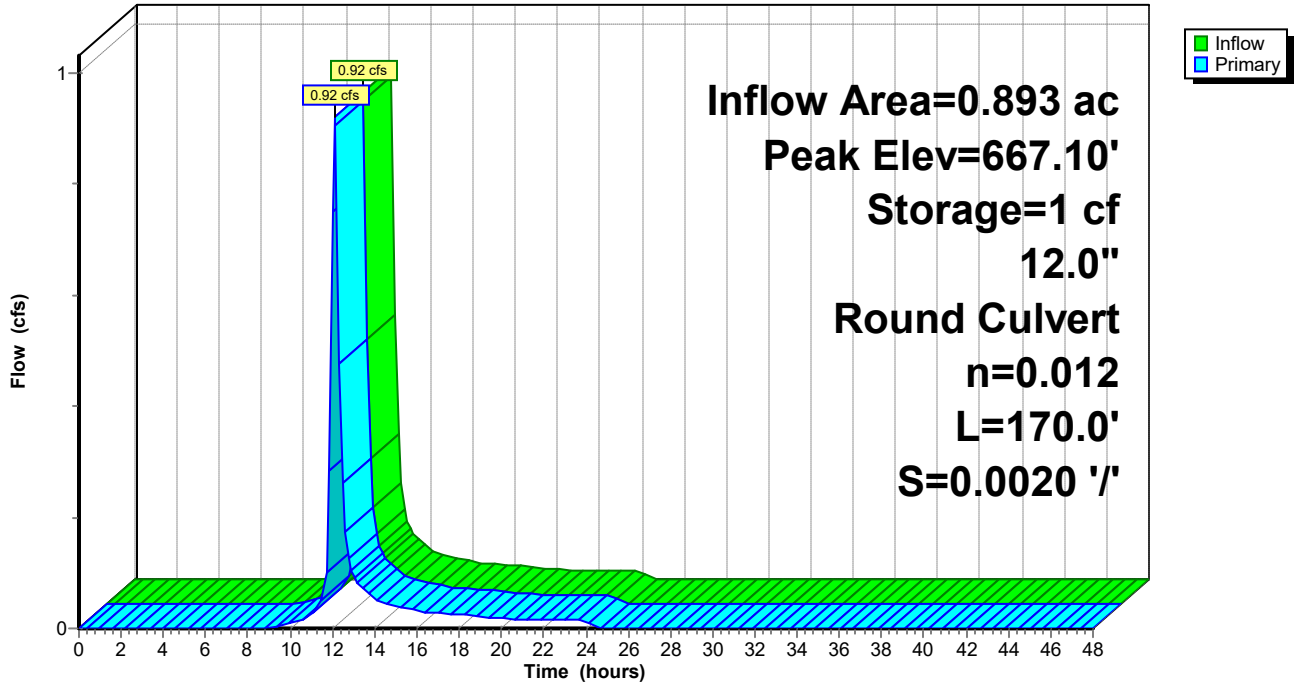

Plug Power - Proposed Conditions 5-15-21

Type II 24-hr 1-yr Rainfall=1.82"

Prepared by {enter your company name here}

Printed 5/20/2021

HydroCAD® 10.10-5a s/n 11585 © 2020 HydroCAD Software Solutions LLC

Page 62

Summary for Pond 27P: CB#4

Inflow Area = 0.946 ac, 62.20% Impervious, Inflow Depth = 1.01" for 1-yr event
 Inflow = 1.05 cfs @ 12.11 hrs, Volume= 0.079 af
 Outflow = 1.04 cfs @ 12.11 hrs, Volume= 0.079 af, Atten= 0%, Lag= 0.0 min
 Primary = 1.04 cfs @ 12.11 hrs, Volume= 0.079 af

Routing by Dyn-Stor-Ind method, Time Span= 0.00-48.00 hrs, dt= 0.15 hrs
 Peak Elev= 666.96' @ 12.25 hrs Surf.Area= 4 sf Storage= 4 cf
 Flood Elev= 669.15' Surf.Area= 5,345 sf Storage= 1,597 cf

Plug-Flow detention time= 0.2 min calculated for 0.079 af (100% of inflow)
 Center-of-Mass det. time= 0.2 min (832.6 - 832.4)

Volume	Invert	Avail.Storage	Storage Description
#1	665.99'	1,597 cf	Custom Stage Data (Prismatic) Listed below (Recalc)

Elevation (feet)	Surf.Area (sq-ft)	Inc.Store (cubic-feet)	Cum.Store (cubic-feet)
665.99	4	0	0
668.40	4	10	10
669.00	3,160	949	959
669.15	5,345	638	1,597

Device	Routing	Invert	Outlet Devices
#1	Primary	665.99'	12.0" Round Culvert L= 40.0' CPP, square edge headwall, Ke= 0.500 Inlet / Outlet Invert= 665.99' / 665.91' S= 0.0020 '/' Cc= 0.900 n= 0.012, Flow Area= 0.79 sf

Primary OutFlow Max=0.00 cfs @ 12.11 hrs HW=666.89' TW=666.91' (Dynamic Tailwater)
 ↑1=Culvert (Controls 0.00 cfs)

Pond 27P: CB#4

Hydrograph

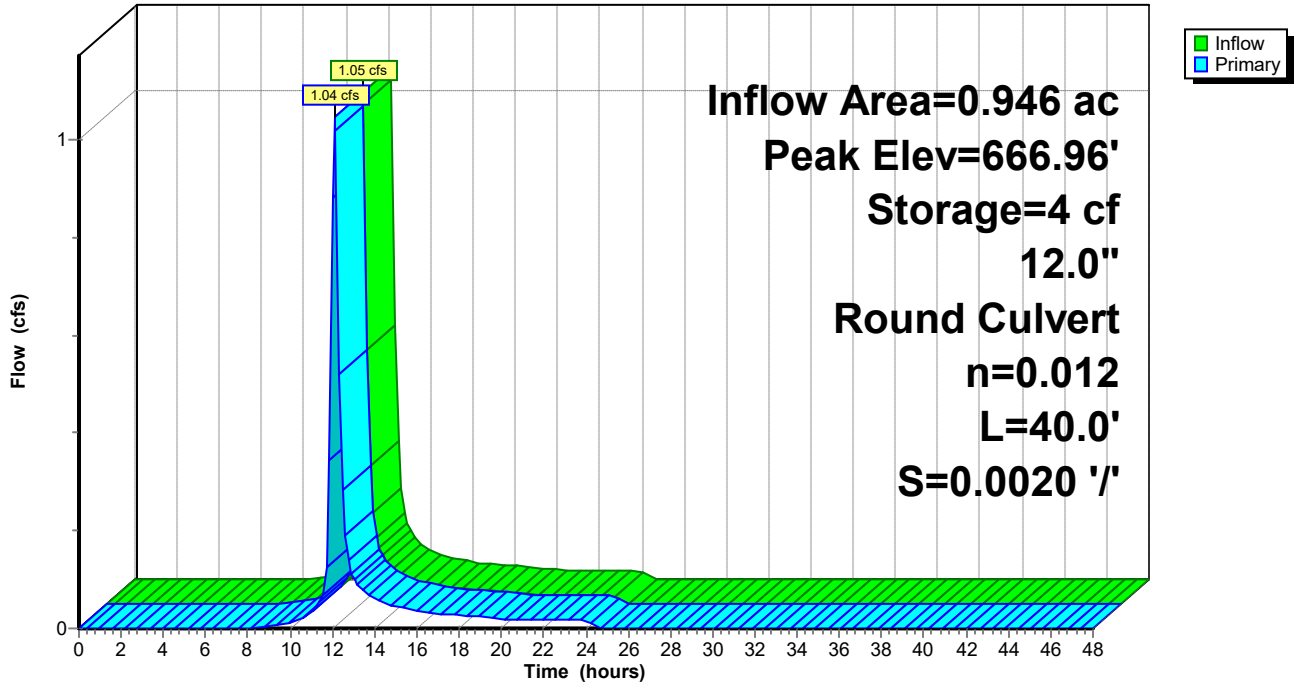

Plug Power - Proposed Conditions 5-15-21

Type II 24-hr 1-yr Rainfall=1.82"

Prepared by {enter your company name here}

Printed 5/20/2021

HydroCAD® 10.10-5a s/n 11585 © 2020 HydroCAD Software Solutions LLC

Page 64

Summary for Pond 28P: CB#15

Inflow Area = 2.230 ac, 65.51% Impervious, Inflow Depth = 1.08" for 1-yr event
 Inflow = 2.45 cfs @ 12.04 hrs, Volume= 0.202 af
 Outflow = 2.45 cfs @ 12.04 hrs, Volume= 0.202 af, Atten= 0%, Lag= 0.0 min
 Primary = 2.45 cfs @ 12.04 hrs, Volume= 0.202 af

Routing by Dyn-Stor-Ind method, Time Span= 0.00-48.00 hrs, dt= 0.15 hrs
 Peak Elev= 666.94' @ 12.18 hrs Surf.Area= 4 sf Storage= 4 cf
 Flood Elev= 669.20' Surf.Area= 4 sf Storage= 13 cf

Plug-Flow detention time= 0.1 min calculated for 0.201 af (100% of inflow)
 Center-of-Mass det. time= 0.1 min (817.3 - 817.2)

Volume	Invert	Avail.Storage	Storage Description
#1	665.91'	13 cf	Custom Stage Data (Prismatic) Listed below (Recalc)

Elevation (feet)	Surf.Area (sq-ft)	Inc.Store (cubic-feet)	Cum.Store (cubic-feet)
665.91	4	0	0
669.20	4	13	13

Device	Routing	Invert	Outlet Devices
#1	Primary	665.91'	18.0" Round Culvert L= 157.0' CPP, square edge headwall, Ke= 0.500 Inlet / Outlet Invert= 665.91' / 665.60' S= 0.0020 '/' Cc= 0.900 n= 0.012, Flow Area= 1.77 sf

Primary OutFlow Max=1.52 cfs @ 12.04 hrs HW=666.87' TW=666.67' (Dynamic Tailwater)

↑**1=Culvert** (Outlet Controls 1.52 cfs @ 1.81 fps)

Pond 28P: CB#15

Hydrograph

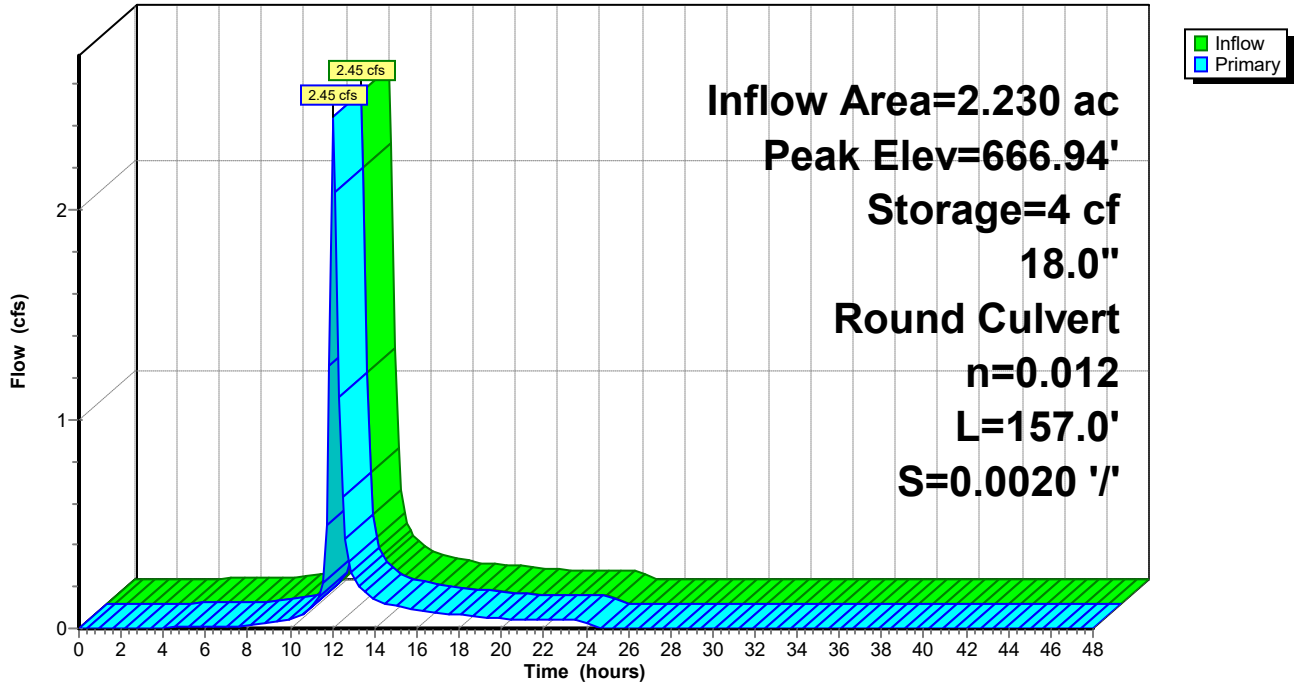

Plug Power - Proposed Conditions 5-15-21

Type II 24-hr 1-yr Rainfall=1.82"

Prepared by {enter your company name here}

Printed 5/20/2021

HydroCAD® 10.10-5a s/n 11585 © 2020 HydroCAD Software Solutions LLC

Page 66

Summary for Pond 29P: Dry Pond

Inflow Area = 0.745 ac, 0.00% Impervious, Inflow Depth = 0.46" for 1-yr event
 Inflow = 0.43 cfs @ 12.00 hrs, Volume= 0.028 af
 Outflow = 0.13 cfs @ 12.29 hrs, Volume= 0.028 af, Atten= 70%, Lag= 16.9 min
 Primary = 0.13 cfs @ 12.29 hrs, Volume= 0.028 af
 Tertiary = 0.00 cfs @ 0.00 hrs, Volume= 0.000 af

Routing by Dyn-Stor-Ind method, Time Span= 0.00-48.00 hrs, dt= 0.15 hrs
 Peak Elev= 662.76' @ 12.29 hrs Surf.Area= 2,936 sf Storage= 321 cf

Plug-Flow detention time= 44.5 min calculated for 0.028 af (100% of inflow)
 Center-of-Mass det. time= 45.5 min (923.0 - 877.5)

Volume	Invert	Avail.Storage	Storage Description
#1	662.56'	37,071 cf	Custom Stage Data (Prismatic) Listed below (Recalc)
Elevation (feet)	Surf.Area (sq-ft)	Inc.Store (cubic-feet)	Cum.Store (cubic-feet)
662.56	300	0	0
663.00	6,155	1,420	1,420
663.35	8,635	2,588	4,008
664.00	10,250	6,138	10,146
665.00	12,040	11,145	21,291
666.00	19,520	15,780	37,071

Device	Routing	Invert	Outlet Devices
#1	Primary	662.56'	12.0" Round Culvert L= 30.0' CPP, square edge headwall, Ke= 0.500 Inlet / Outlet Invert= 662.56' / 662.50' S= 0.0020 '/' Cc= 0.900 n= 0.012, Flow Area= 0.79 sf
#2	Primary	662.56'	12.0" Round Culvert L= 30.0' CPP, square edge headwall, Ke= 0.500 Inlet / Outlet Invert= 662.56' / 662.50' S= 0.0020 '/' Cc= 0.900 n= 0.012, Flow Area= 0.79 sf
#3	Device 1	662.56'	3.0" Vert. Orifice/Grate C= 0.600 Limited to weir flow at low heads
#4	Device 2	662.56'	3.0" Vert. Orifice/Grate C= 0.600 Limited to weir flow at low heads
#5	Device 1	663.06'	6.0" Vert. Orifice/Grate C= 0.600 Limited to weir flow at low heads
#6	Device 2	663.06'	6.0" Vert. Orifice/Grate C= 0.600 Limited to weir flow at low heads
#7	Device 1	665.20'	1.4" x 4.5" Horiz. Orifice/Grate X 72.00 C= 0.600 Limited to weir flow at low heads
#8	Device 2	665.20'	1.4" x 4.5" Horiz. Orifice/Grate X 72.00 C= 0.600 Limited to weir flow at low heads
#9	Tertiary	665.70'	100.0' long x 2.0' breadth Broad-Crested Rectangular Weir Head (feet) 0.20 0.40 0.60 0.80 1.00 1.20 1.40 1.60 1.80 2.00 2.50 3.00 3.50 Coef. (English) 2.54 2.61 2.61 2.60 2.66 2.70 2.77 2.89 2.88 2.85 3.07 3.20 3.32

Plug Power - Proposed Conditions 5-15-21

Prepared by {enter your company name here}

HydroCAD® 10.10-5a s/n 11585 © 2020 HydroCAD Software Solutions LLC

Type II 24-hr 1-yr Rainfall=1.82"

Printed 5/20/2021

Page 67

Primary OutFlow Max=0.13 cfs @ 12.29 hrs HW=662.76' TW=662.47' (Dynamic Tailwater)

- 1=Culvert (Passes 0.06 cfs of 0.09 cfs potential flow)
- 3=Orifice/Grate (Orifice Controls 0.06 cfs @ 1.51 fps)
- 5=Orifice/Grate (Controls 0.00 cfs)
- 7=Orifice/Grate (Controls 0.00 cfs)
- 2=Culvert (Passes 0.06 cfs of 0.09 cfs potential flow)
- 4=Orifice/Grate (Orifice Controls 0.06 cfs @ 1.51 fps)
- 6=Orifice/Grate (Controls 0.00 cfs)
- 8=Orifice/Grate (Controls 0.00 cfs)

Tertiary OutFlow Max=0.00 cfs @ 0.00 hrs HW=662.56' TW=662.30' (Dynamic Tailwater)

- 9=Broad-Crested Rectangular Weir (Controls 0.00 cfs)

Pond 29P: Dry Pond

Hydrograph

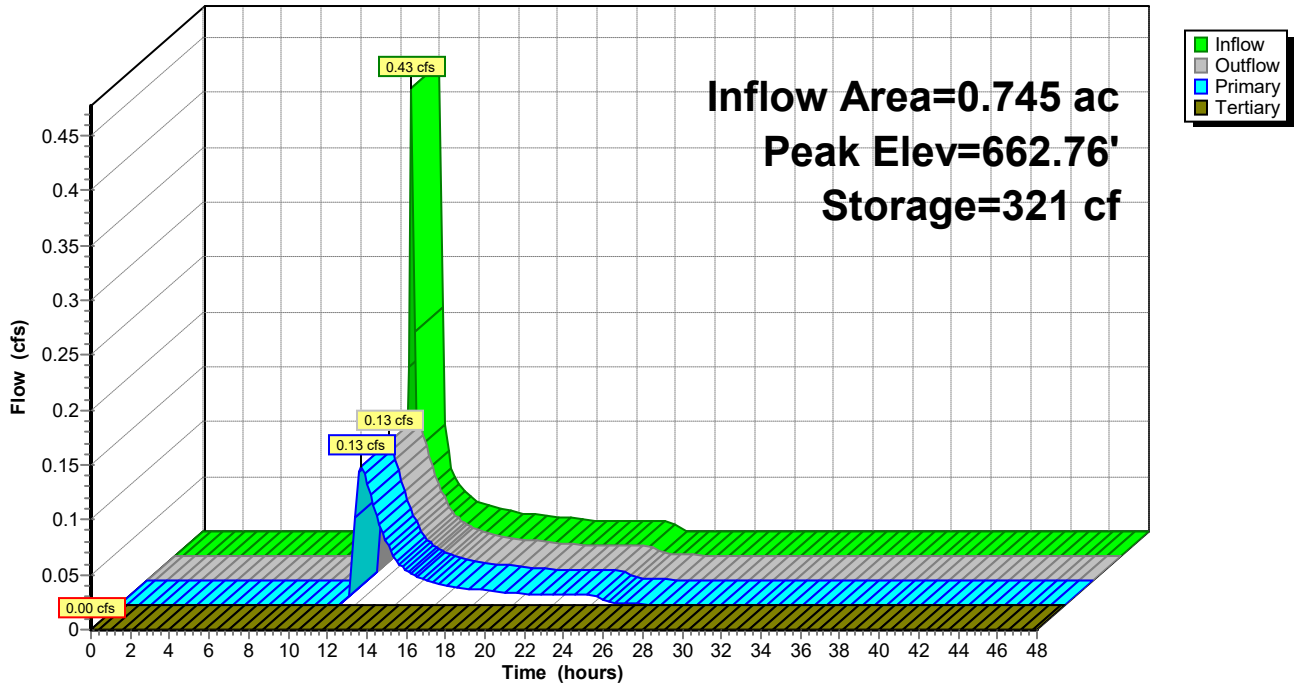

Plug Power - Proposed Conditions 5-15-21

Type II 24-hr 1-yr Rainfall=1.82"

Prepared by {enter your company name here}

Printed 5/20/2021

HydroCAD® 10.10-5a s/n 11585 © 2020 HydroCAD Software Solutions LLC

Page 68

Summary for Pond 31P: CB#18

Inflow Area = 2.692 ac, 56.86% Impervious, Inflow Depth = 0.98" for 1-yr event
 Inflow = 2.57 cfs @ 12.05 hrs, Volume= 0.221 af
 Outflow = 2.57 cfs @ 12.05 hrs, Volume= 0.221 af, Atten= 0%, Lag= 0.0 min
 Primary = 2.57 cfs @ 12.05 hrs, Volume= 0.221 af

Routing by Dyn-Stor-Ind method, Time Span= 0.00-48.00 hrs, dt= 0.15 hrs
 Peak Elev= 666.80' @ 12.17 hrs Surf.Area= 4 sf Storage= 5 cf
 Flood Elev= 669.45' Surf.Area= 9,895 sf Storage= 3,378 cf

Plug-Flow detention time= 0.1 min calculated for 0.220 af (100% of inflow)
 Center-of-Mass det. time= 0.1 min (823.3 - 823.2)

Volume	Invert	Avail.Storage	Storage Description
#1	665.60'	3,378 cf	Custom Stage Data (Prismatic) Listed below (Recalc)
Elevation (feet)	Surf.Area (sq-ft)	Inc.Store (cubic-feet)	Cum.Store (cubic-feet)
665.60	4	0	0
668.55	4	12	12
669.00	2,530	570	582
669.45	9,895	2,796	3,378

Device	Routing	Invert	Outlet Devices
#1	Primary	665.60'	18.0" Round Culvert L= 83.0' CPP, square edge headwall, Ke= 0.500 Inlet / Outlet Invert= 665.60' / 665.43' S= 0.0020 '/' Cc= 0.900 n= 0.012, Flow Area= 1.77 sf

Primary OutFlow Max=1.14 cfs @ 12.05 hrs HW=666.68' TW=666.62' (Dynamic Tailwater)
 ↑**1=Culvert** (Outlet Controls 1.14 cfs @ 1.17 fps)

Pond 31P: CB#18

Hydrograph

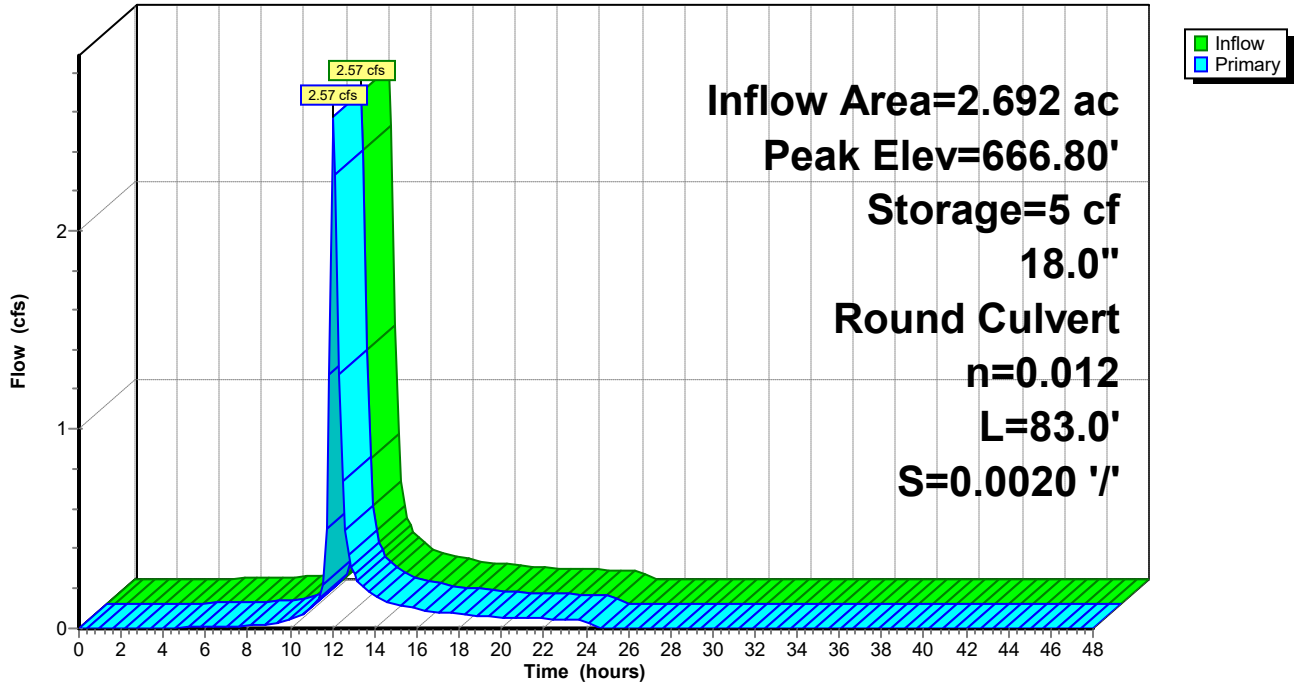

Plug Power - Proposed Conditions 5-15-21

Type II 24-hr 1-yr Rainfall=1.82"

Prepared by {enter your company name here}

Printed 5/20/2021

HydroCAD® 10.10-5a s/n 11585 © 2020 HydroCAD Software Solutions LLC

Page 70

Summary for Pond 33P: CB#26

Inflow Area = 0.831 ac, 69.35% Impervious, Inflow Depth = 1.08" for 1-yr event
Inflow = 0.98 cfs @ 12.10 hrs, Volume= 0.075 af
Outflow = 0.98 cfs @ 12.11 hrs, Volume= 0.075 af, Atten= 0%, Lag= 0.0 min
Primary = 0.98 cfs @ 12.11 hrs, Volume= 0.075 af

Routing by Dyn-Stor-Ind method, Time Span= 0.00-48.00 hrs, dt= 0.15 hrs
Peak Elev= 666.15' @ 12.14 hrs Surf.Area= 4 sf Storage= 3 cf
Flood Elev= 669.00' Surf.Area= 3,160 sf Storage= 961 cf

Plug-Flow detention time= 0.2 min calculated for 0.074 af (100% of inflow)
Center-of-Mass det. time= 0.2 min (827.0 - 826.9)

Volume	Invert	Avail.Storage	Storage Description
#1	665.42'	1,599 cf	Custom Stage Data (Prismatic) Listed below (Recalc)

Elevation (feet)	Surf.Area (sq-ft)	Inc.Store (cubic-feet)	Cum.Store (cubic-feet)
665.42	4	0	0
668.40	4	12	12
669.00	3,160	949	961
669.15	5,345	638	1,599

Device	Routing	Invert	Outlet Devices
#1	Primary	665.42'	12.0" Round Culvert L= 175.0' CPP, square edge headwall, Ke= 0.500 Inlet / Outlet Invert= 665.42' / 665.07' S= 0.0020 '/' Cc= 0.900 n= 0.012, Flow Area= 0.79 sf

Primary OutFlow Max=0.76 cfs @ 12.11 hrs HW=666.12' TW=665.82' (Dynamic Tailwater)
↑**1=Culvert** (Outlet Controls 0.76 cfs @ 1.81 fps)

Plug Power - Proposed Conditions 5-15-21

Prepared by {enter your company name here}

HydroCAD® 10.10-5a s/n 11585 © 2020 HydroCAD Software Solutions LLC

Type II 24-hr 1-yr Rainfall=1.82"

Printed 5/20/2021

Page 71

Pond 33P: CB#26

Hydrograph

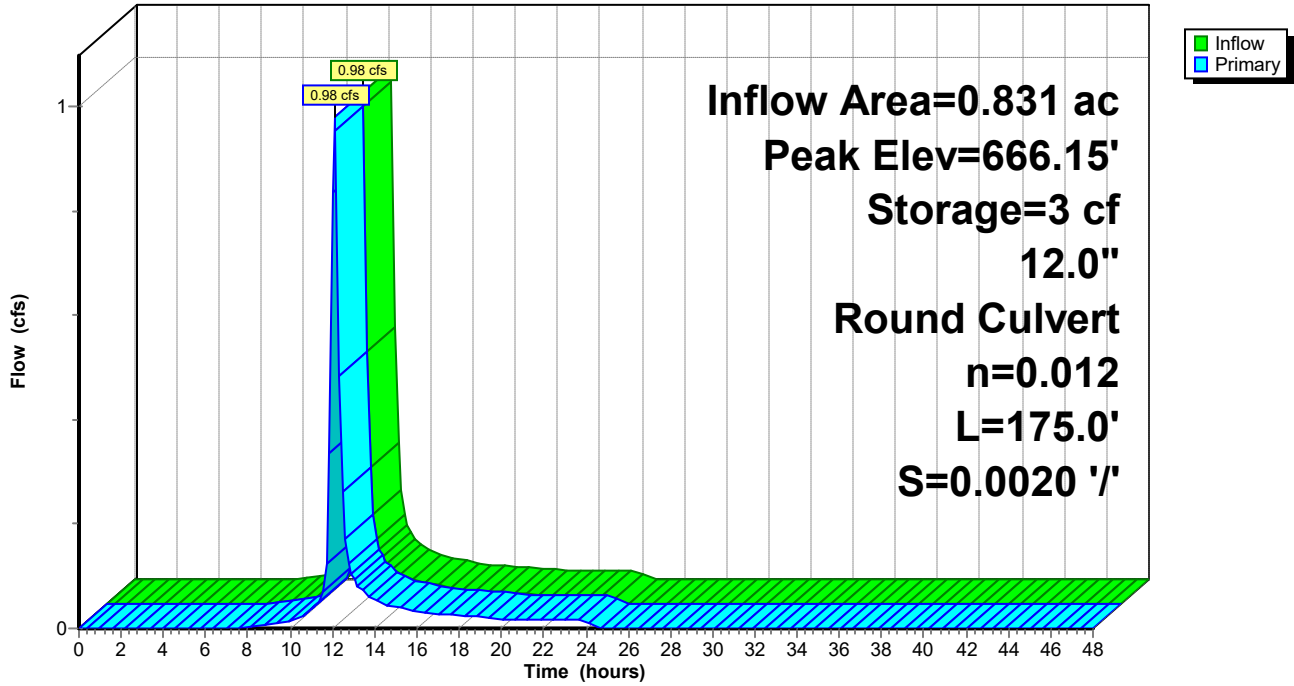

Plug Power - Proposed Conditions 5-15-21

Type II 24-hr 1-yr Rainfall=1.82"

Prepared by {enter your company name here}

Printed 5/20/2021

HydroCAD® 10.10-5a s/n 11585 © 2020 HydroCAD Software Solutions LLC

Page 72

Summary for Pond 37P: CB#28

Inflow Area = 1.256 ac, 61.06% Impervious, Inflow Depth = 0.99" for 1-yr event
Inflow = 1.35 cfs @ 12.12 hrs, Volume= 0.104 af
Outflow = 1.35 cfs @ 12.12 hrs, Volume= 0.104 af, Atten= 0%, Lag= 0.0 min
Primary = 1.35 cfs @ 12.12 hrs, Volume= 0.104 af

Routing by Dyn-Stor-Ind method, Time Span= 0.00-48.00 hrs, dt= 0.15 hrs
Peak Elev= 665.93' @ 12.74 hrs Surf.Area= 4 sf Storage= 3 cf
Flood Elev= 669.75' Surf.Area= 5,170 sf Storage= 1,569 cf

Plug-Flow detention time= 0.1 min calculated for 0.103 af (100% of inflow)
Center-of-Mass det. time= 0.2 min (833.5 - 833.4)

Volume	Invert	Avail.Storage	Storage Description
#1	665.07'	1,569 cf	Custom Stage Data (Prismatic) Listed below (Recalc)

Elevation (feet)	Surf.Area (sq-ft)	Inc.Store (cubic-feet)	Cum.Store (cubic-feet)
665.07	4	0	0
669.15	4	16	16
669.75	5,170	1,552	1,569

Device	Routing	Invert	Outlet Devices
#1	Primary	665.07'	15.0" Round Culvert L= 214.0' CPP, square edge headwall, Ke= 0.500 Inlet / Outlet Invert= 665.07' / 664.64' S= 0.0020 '/' Cc= 0.900 n= 0.012, Flow Area= 1.23 sf

Primary OutFlow Max=0.97 cfs @ 12.12 hrs HW=665.83' TW=665.53' (Dynamic Tailwater)
↑**1=Culvert** (Outlet Controls 0.97 cfs @ 1.78 fps)

Pond 37P: CB#28

Hydrograph

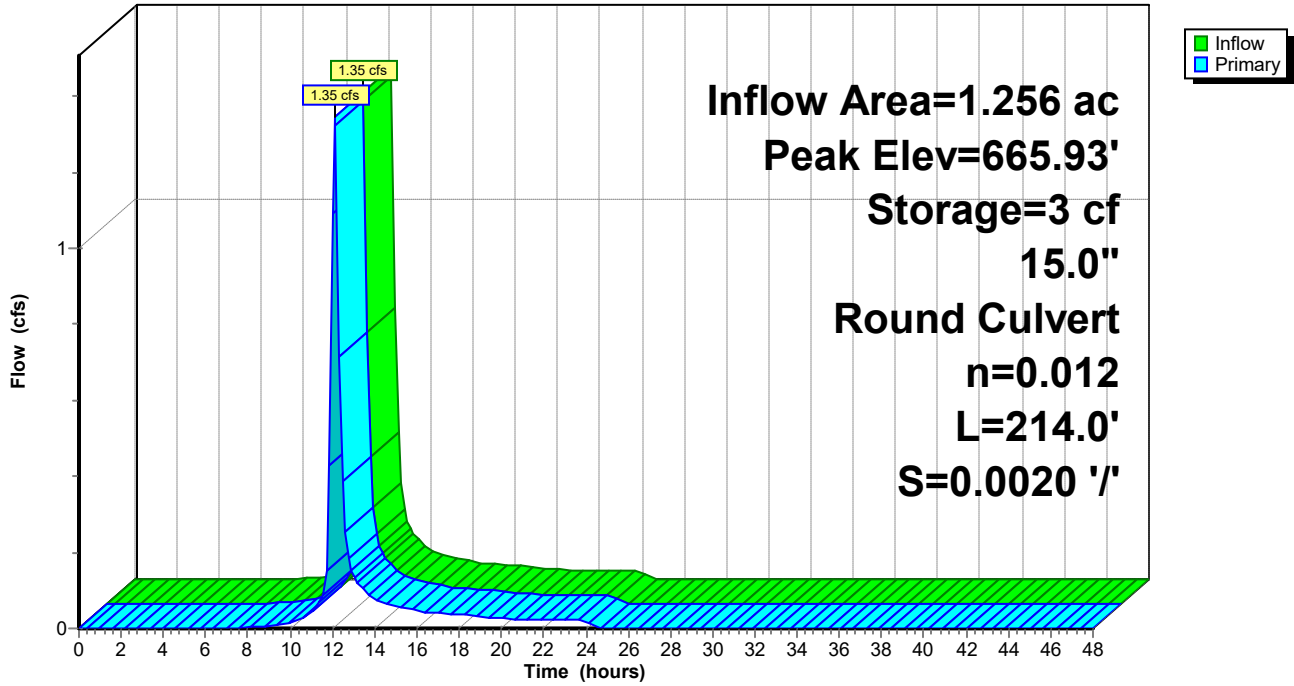

Plug Power - Proposed Conditions 5-15-21

Type II 24-hr 1-yr Rainfall=1.82"

Prepared by {enter your company name here}

Printed 5/20/2021

HydroCAD® 10.10-5a s/n 11585 © 2020 HydroCAD Software Solutions LLC

Page 74

Summary for Pond 39P: CB#30

Inflow Area = 2.166 ac, 42.53% Impervious, Inflow Depth = 0.82" for 1-yr event
Inflow = 1.85 cfs @ 12.13 hrs, Volume= 0.147 af
Outflow = 1.85 cfs @ 12.13 hrs, Volume= 0.147 af, Atten= 0%, Lag= 0.0 min
Primary = 1.85 cfs @ 12.13 hrs, Volume= 0.147 af

Routing by Dyn-Stor-Ind method, Time Span= 0.00-48.00 hrs, dt= 0.15 hrs
Peak Elev= 665.92' @ 12.60 hrs Surf.Area= 4 sf Storage= 5 cf
Flood Elev= 668.00' Surf.Area= 220 sf Storage= 19 cf

Plug-Flow detention time= 1.0 min calculated for 0.147 af (100% of inflow)
Center-of-Mass det. time= 0.1 min (845.6 - 845.5)

Volume	Invert	Avail.Storage	Storage Description
#1	664.64'	19 cf	Custom Stage Data (Prismatic) Listed below (Recalc)

Elevation (feet)	Surf.Area (sq-ft)	Inc.Store (cubic-feet)	Cum.Store (cubic-feet)
664.64	4	0	0
667.95	4	13	13
668.00	220	6	19

Device	Routing	Invert	Outlet Devices
#1	Primary	664.64'	18.0" Round Culvert L= 150.0' CPP, square edge headwall, Ke= 0.500 Inlet / Outlet Invert= 664.64' / 664.34' S= 0.0020 '/' Cc= 0.900 n= 0.012, Flow Area= 1.77 sf

Primary OutFlow Max=0.00 cfs @ 12.13 hrs HW=665.55' TW=665.57' (Dynamic Tailwater)
↑1=Culvert (Controls 0.00 cfs)

Plug Power - Proposed Conditions 5-15-21

Prepared by {enter your company name here}

HydroCAD® 10.10-5a s/n 11585 © 2020 HydroCAD Software Solutions LLC

Type II 24-hr 1-yr Rainfall=1.82"

Printed 5/20/2021

Page 75

Pond 39P: CB#30

Hydrograph

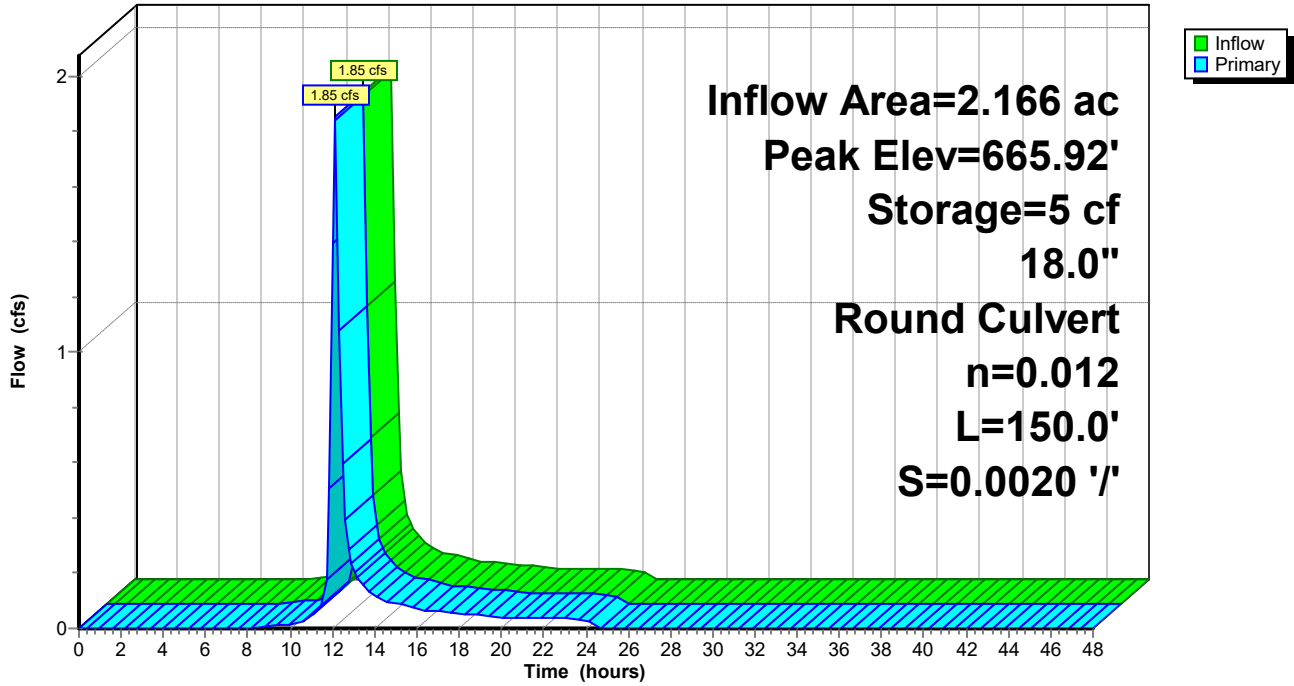

Plug Power - Proposed Conditions 5-15-21

Type II 24-hr 1-yr Rainfall=1.82"

Prepared by {enter your company name here}

Printed 5/20/2021

HydroCAD® 10.10-5a s/n 11585 © 2020 HydroCAD Software Solutions LLC

Page 76

Summary for Pond 41P: CB#32

Inflow Area = 2.889 ac, 56.91% Impervious, Inflow Depth = 1.01" for 1-yr event
Inflow = 2.94 cfs @ 12.14 hrs, Volume= 0.243 af
Outflow = 2.93 cfs @ 12.14 hrs, Volume= 0.243 af, Atten= 0%, Lag= 0.0 min
Primary = 2.93 cfs @ 12.14 hrs, Volume= 0.243 af

Routing by Dyn-Stor-Ind method, Time Span= 0.00-48.00 hrs, dt= 0.15 hrs
Peak Elev= 665.91' @ 12.45 hrs Surf.Area= 4 sf Storage= 6 cf
Flood Elev= 668.00' Surf.Area= 5 sf Storage= 15 cf

Plug-Flow detention time= 0.1 min calculated for 0.243 af (100% of inflow)
Center-of-Mass det. time= 0.1 min (820.3 - 820.2)

Volume	Invert	Avail.Storage	Storage Description
#1	664.34'	3,522 cf	Custom Stage Data (Prismatic) Listed below (Recalc)

Elevation (feet)	Surf.Area (sq-ft)	Inc.Store (cubic-feet)	Cum.Store (cubic-feet)
664.34	4	0	0
667.95	4	14	14
688.05	345	3,507	3,522

Device	Routing	Invert	Outlet Devices
#1	Primary	664.34'	24.0" Round Culvert L= 166.0' CPP, square edge headwall, Ke= 0.500 Inlet / Outlet Invert= 664.34' / 664.01' S= 0.0020 '/' Cc= 0.900 n= 0.012, Flow Area= 3.14 sf

Primary OutFlow Max=0.00 cfs @ 12.14 hrs HW=665.58' TW=665.72' (Dynamic Tailwater)
↑1=Culvert (Controls 0.00 cfs)

Plug Power - Proposed Conditions 5-15-21

Prepared by {enter your company name here}

HydroCAD® 10.10-5a s/n 11585 © 2020 HydroCAD Software Solutions LLC

Type II 24-hr 1-yr Rainfall=1.82"

Printed 5/20/2021

Page 77

Pond 41P: CB#32

Hydrograph

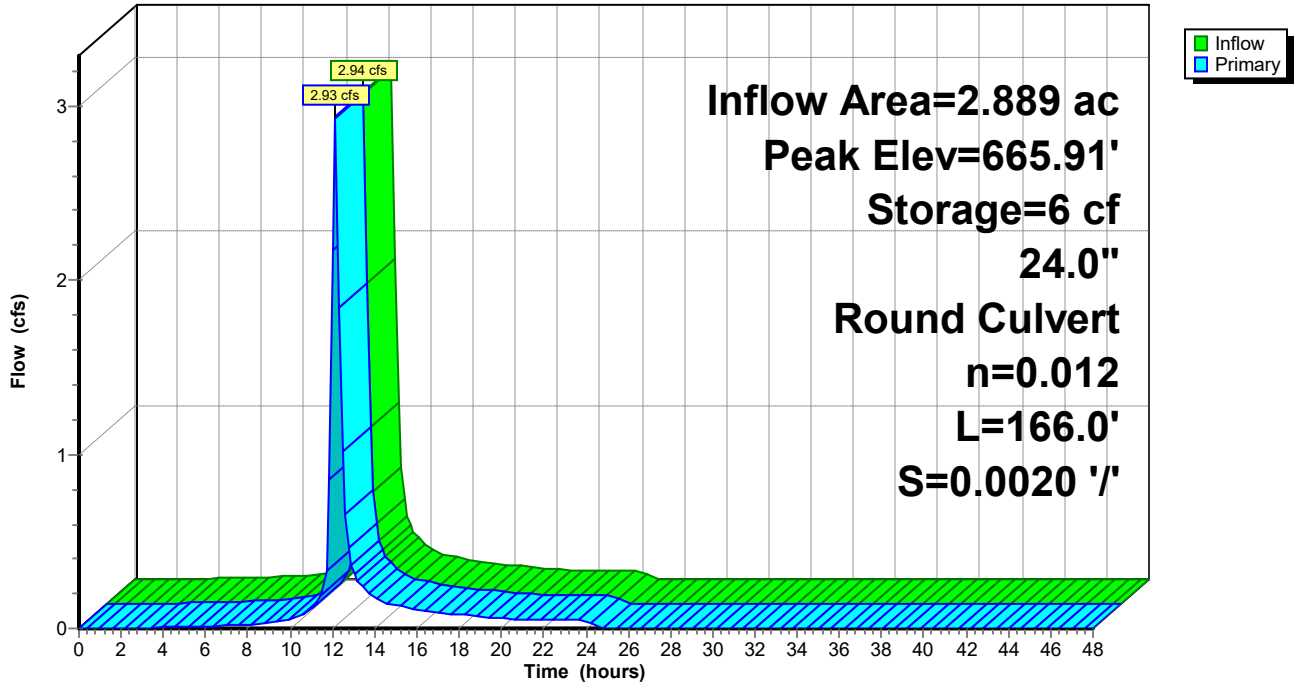

Plug Power - Proposed Conditions 5-15-21

Prepared by {enter your company name here}

HydroCAD® 10.10-5a s/n 11585 © 2020 HydroCAD Software Solutions LLC

Type II 24-hr 1-yr Rainfall=1.82"

Printed 5/20/2021

Page 78

Summary for Pond 44P: CB#24

Inflow Area = 4.895 ac, 67.05% Impervious, Inflow Depth = 1.12" for 1-yr event
Inflow = 5.69 cfs @ 11.99 hrs, Volume= 0.458 af
Outflow = 5.69 cfs @ 11.99 hrs, Volume= 0.458 af, Atten= 0%, Lag= 0.0 min
Primary = 5.69 cfs @ 11.99 hrs, Volume= 0.458 af

Routing by Dyn-Stor-Ind method, Time Span= 0.00-48.00 hrs, dt= 0.15 hrs

Peak Elev= 666.45' @ 11.99 hrs

Flood Elev= 669.85'

Device #	Routing	Invert	Outlet Devices
#1	Primary	665.12'	24.0" Round Culvert L= 105.0' CPP, square edge headwall, Ke= 0.500 Inlet / Outlet Invert= 665.12' / 664.91' S= 0.0020 '/ Cc= 0.900 n= 0.012, Flow Area= 3.14 sf

Primary OutFlow Max=5.54 cfs @ 11.99 hrs HW=666.43' TW=665.38' (Dynamic Tailwater)
↑1=Culvert (Barrel Controls 5.54 cfs @ 3.62 fps)

Pond 44P: CB#24

Hydrograph

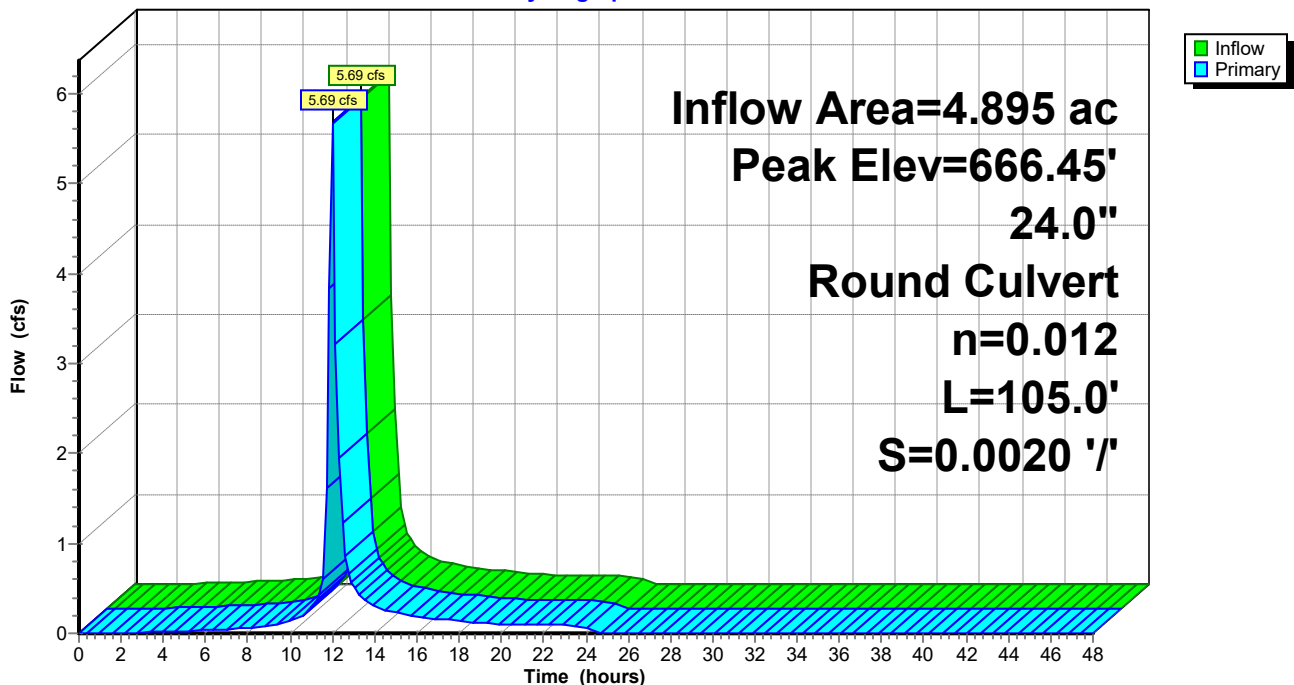

Plug Power - Proposed Conditions 5-15-21

Type II 24-hr 1-yr Rainfall=1.82"

Prepared by {enter your company name here}

Printed 5/20/2021

HydroCAD® 10.10-5a s/n 11585 © 2020 HydroCAD Software Solutions LLC

Page 79

Summary for Pond 46P: CB#20

Inflow Area = 3.433 ac, 66.17% Impervious, Inflow Depth = 1.12" for 1-yr event
 Inflow = 3.91 cfs @ 12.00 hrs, Volume= 0.319 af
 Outflow = 3.91 cfs @ 12.00 hrs, Volume= 0.319 af, Atten= 0%, Lag= 0.0 min
 Primary = 3.91 cfs @ 12.00 hrs, Volume= 0.319 af

Routing by Dyn-Stor-Ind method, Time Span= 0.00-48.00 hrs, dt= 0.15 hrs
 Peak Elev= 666.67' @ 12.08 hrs
 Flood Elev= 669.85'

Device	Routing	Invert	Outlet Devices
#1	Primary	665.43'	24.0" Round Culvert L= 157.0' CPP, square edge headwall, Ke= 0.500 Inlet / Outlet Invert= 665.43' / 665.12' S= 0.0020 '/ Cc= 0.900 n= 0.012, Flow Area= 3.14 sf

Primary OutFlow Max=2.55 cfs @ 12.00 hrs HW=666.62' TW=666.44' (Dynamic Tailwater)
 ↑1=Culvert (Outlet Controls 2.55 cfs @ 1.88 fps)

Pond 46P: CB#20

Hydrograph

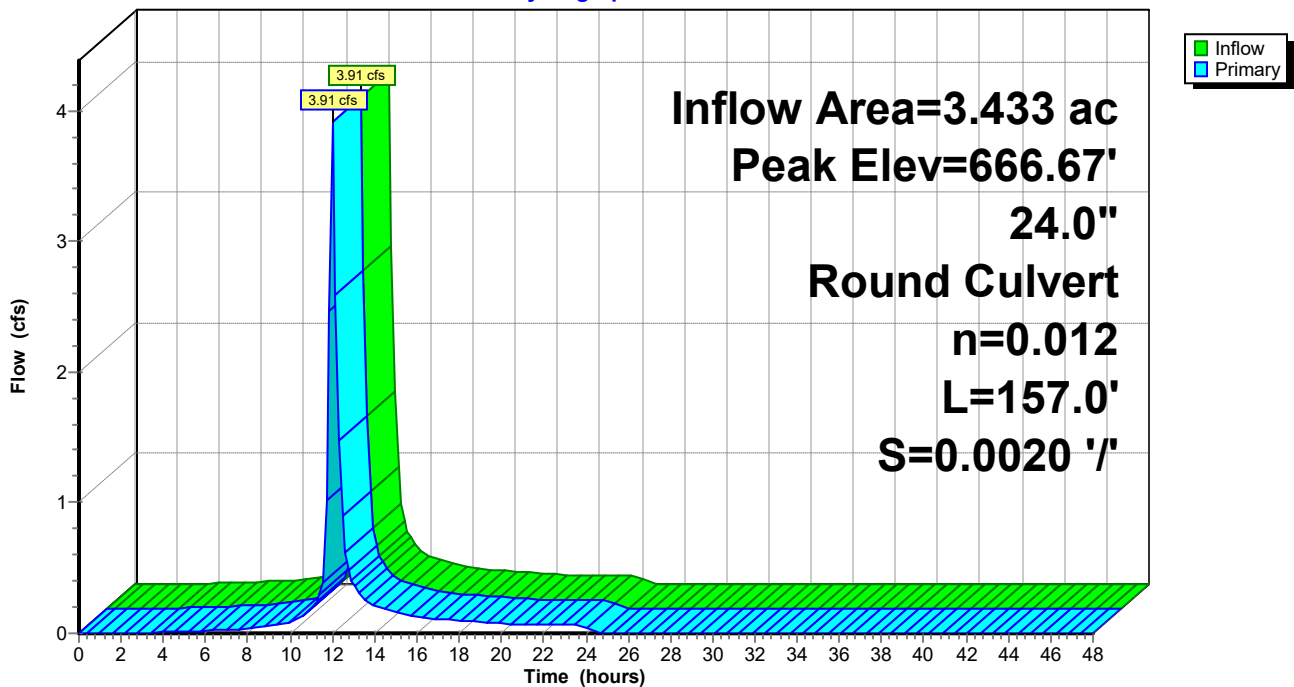

Plug Power - Proposed Conditions 5-15-21

Type II 24-hr 1-yr Rainfall=1.82"

Prepared by {enter your company name here}

Printed 5/20/2021

HydroCAD® 10.10-5a s/n 11585 © 2020 HydroCAD Software Solutions LLC

Page 80

Summary for Pond 50P: YD#8

Inflow Area = 2.660 ac, 32.37% Impervious, Inflow Depth = 0.70" for 1-yr event
Inflow = 1.69 cfs @ 12.20 hrs, Volume= 0.154 af
Outflow = 1.69 cfs @ 12.20 hrs, Volume= 0.154 af, Atten= 0%, Lag= 0.0 min
Primary = 1.69 cfs @ 12.20 hrs, Volume= 0.154 af

Routing by Dyn-Stor-Ind method, Time Span= 0.00-48.00 hrs, dt= 0.15 hrs
Peak Elev= 667.83' @ 12.25 hrs Surf.Area= 1 sf Storage= 1 cf
Flood Elev= 669.90' Surf.Area= 8,385 sf Storage= 3,357 cf

Plug-Flow detention time= 0.0 min calculated for 0.154 af (100% of inflow)
Center-of-Mass det. time= 0.0 min (865.7 - 865.6)

Volume	Invert	Avail.Storage	Storage Description
#1	666.95'	3,357 cf	Custom Stage Data (Prismatic) Listed below (Recalc)

Elevation (feet)	Surf.Area (sq-ft)	Inc.Store (cubic-feet)	Cum.Store (cubic-feet)
666.95	1	0	0
669.10	1	2	2
669.90	8,385	3,354	3,357

Device	Routing	Invert	Outlet Devices
#1	Primary	666.95'	18.0" Round Culvert L= 122.0' CPP, square edge headwall, Ke= 0.500 Inlet / Outlet Invert= 666.95' / 666.71' S= 0.0020 '/' Cc= 0.900 n= 0.012, Flow Area= 1.77 sf

Primary OutFlow Max=1.47 cfs @ 12.20 hrs HW=667.80' TW=667.55' (Dynamic Tailwater)
↑**1=Culvert** (Outlet Controls 1.47 cfs @ 2.06 fps)

Pond 50P: YD#8

Hydrograph

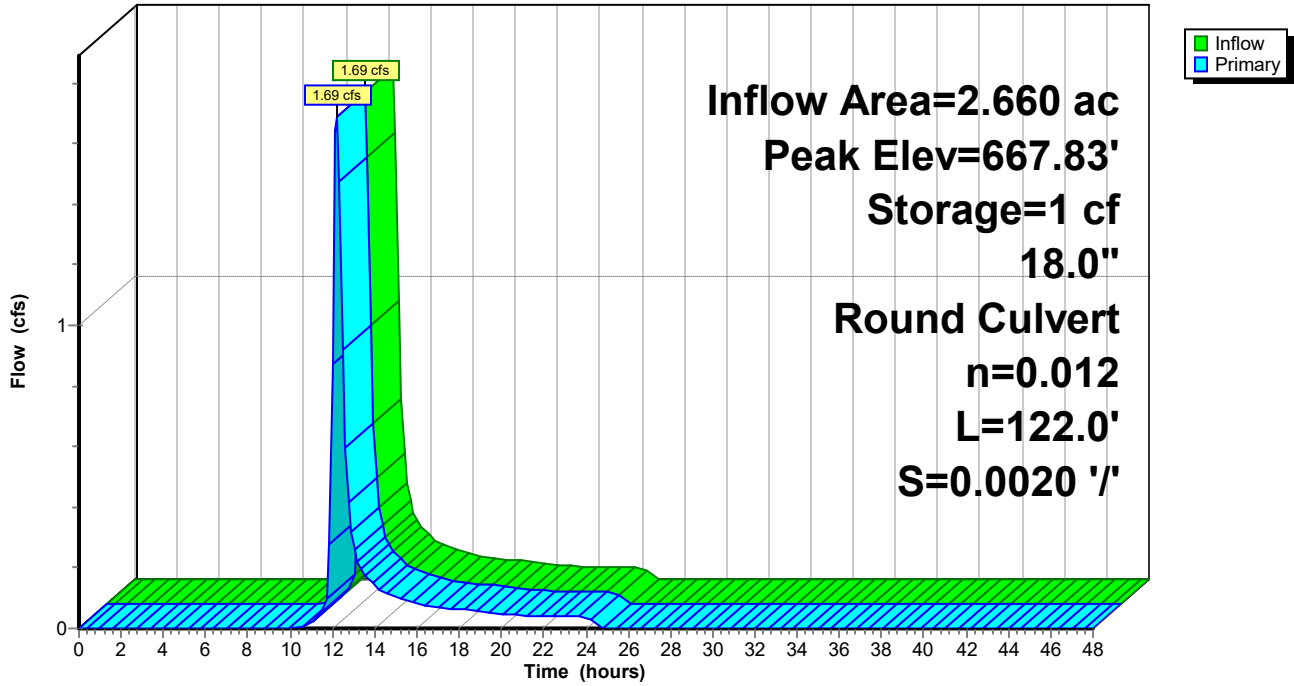

Plug Power - Proposed Conditions 5-15-21

Type II 24-hr 1-yr Rainfall=1.82"

Prepared by {enter your company name here}

Printed 5/20/2021

HydroCAD® 10.10-5a s/n 11585 © 2020 HydroCAD Software Solutions LLC

Page 82

Summary for Pond 51P: YD#6

Inflow Area = 1.879 ac, 30.11% Impervious, Inflow Depth = 0.67" for 1-yr event
 Inflow = 1.12 cfs @ 12.21 hrs, Volume= 0.104 af
 Outflow = 1.12 cfs @ 12.21 hrs, Volume= 0.104 af, Atten= 0%, Lag= 0.0 min
 Primary = 1.12 cfs @ 12.21 hrs, Volume= 0.104 af

Routing by Dyn-Stor-Ind method, Time Span= 0.00-48.00 hrs, dt= 0.15 hrs
 Peak Elev= 668.01' @ 12.31 hrs Surf.Area= 1 sf Storage= 1 cf
 Flood Elev= 669.70' Surf.Area= 7,065 sf Storage= 1,592 cf

Plug-Flow detention time= 0.0 min calculated for 0.104 af (100% of inflow)
 Center-of-Mass det. time= 0.0 min (869.1 - 869.1)

Volume	Invert	Avail.Storage	Storage Description
#1	667.23'	1,592 cf	Custom Stage Data (Prismatic) Listed below (Recalc)

Elevation (feet)	Surf.Area (sq-ft)	Inc.Store (cubic-feet)	Cum.Store (cubic-feet)
667.23	1	0	0
669.25	1	2	2
669.70	7,065	1,590	1,592

Device	Routing	Invert	Outlet Devices
#1	Primary	667.23'	15.0" Round Culvert L= 138.0' CPP, square edge headwall, Ke= 0.500 Inlet / Outlet Invert= 667.23' / 666.95' S= 0.0020 '/' Cc= 0.900 n= 0.012, Flow Area= 1.23 sf

Primary OutFlow Max=0.71 cfs @ 12.21 hrs HW=667.95' TW=667.80' (Dynamic Tailwater)
 ↑**1=Culvert** (Outlet Controls 0.71 cfs @ 1.42 fps)

Pond 51P: YD#6

Hydrograph

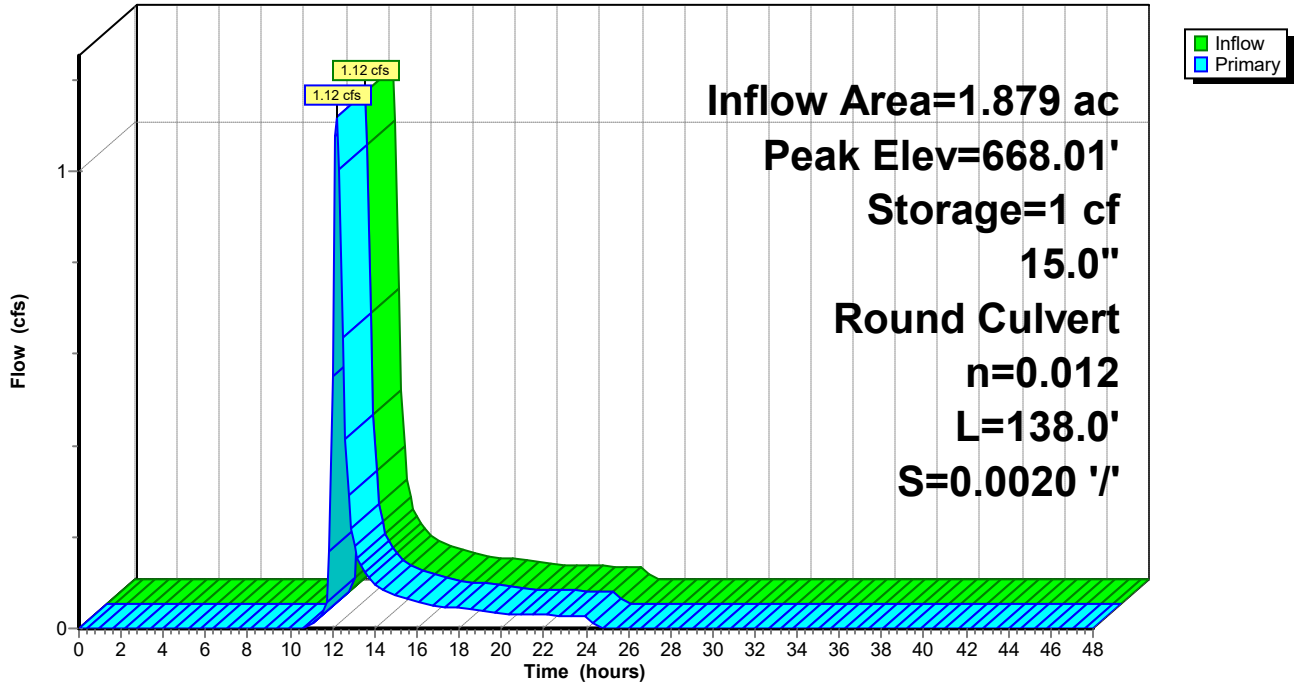

Summary for Link 52L: Total Site Discharge

Inflow Area = 29.096 ac, 42.99% Impervious, Inflow Depth = 0.84" for 1-yr event
Inflow = 1.87 cfs @ 12.91 hrs, Volume= 2.033 af
Primary = 1.87 cfs @ 12.91 hrs, Volume= 2.033 af, Atten= 0%, Lag= 0.0 min

Primary outflow = Inflow, Time Span= 0.00-48.00 hrs, dt= 0.15 hrs

Link 52L: Total Site Discharge

Hydrograph

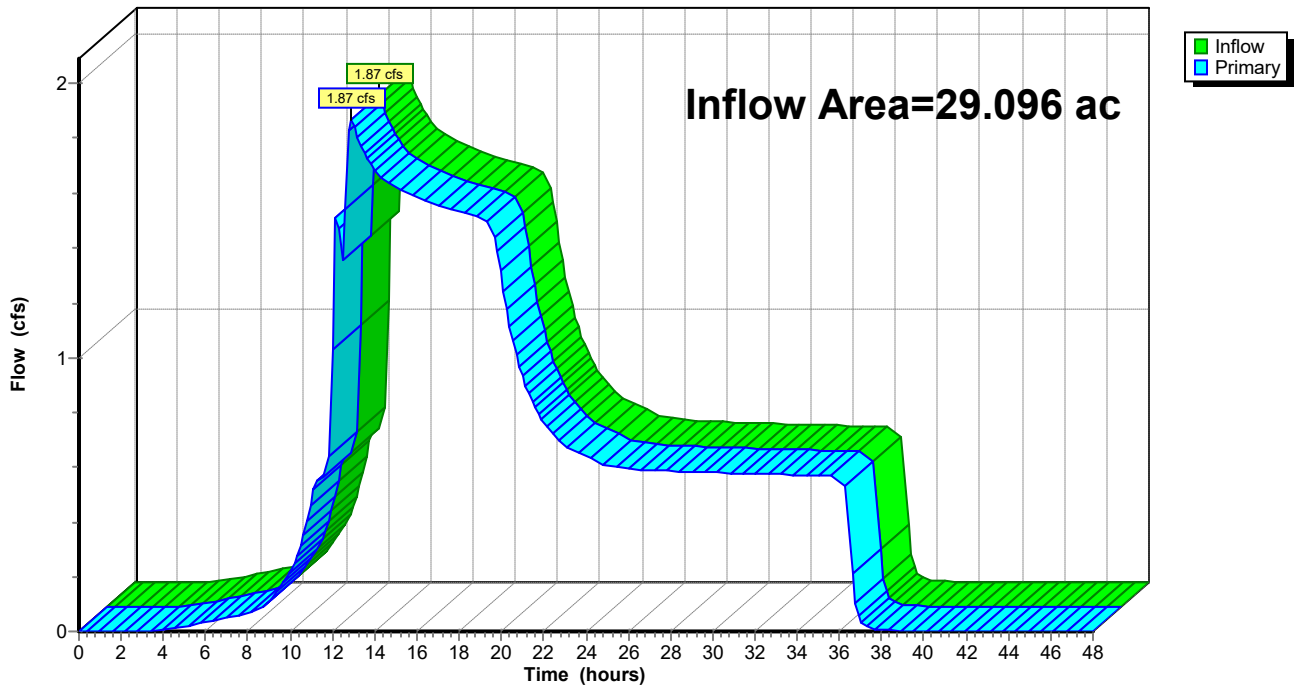

Plug Power - Proposed Conditions 5-15-21

Type II 24-hr 10-yr Rainfall=3.04"

Prepared by {enter your company name here}

Printed 5/20/2021

HydroCAD® 10.10-5a s/n 11585 © 2020 HydroCAD Software Solutions LLC

Page 85

Time span=0.00-48.00 hrs, dt=0.15 hrs, 321 points
Runoff by SCS TR-20 method, UH=SCS, Weighted-CN
Reach routing by Dyn-Stor-Ind method - Pond routing by Dyn-Stor-Ind method

Subcatchment 1S: Prop. Area to SW Runoff Area=25,495 sf 0.00% Impervious Runoff Depth=1.22"
Flow Length=90' Slope=0.0200 '/' Tc=20.5 min CN=79 Runoff=0.73 cfs 0.059 af

Subcatchment 2S: Prop. Area to SE Runoff Area=12,470 sf 0.00% Impervious Runoff Depth=1.22"
Flow Length=100' Slope=0.0150 '/' Tc=19.6 min CN=79 Runoff=0.37 cfs 0.029 af

Subcatchment 3S: Prop. Area to West Runoff Area=38,190 sf 0.00% Impervious Runoff Depth=1.22"
Flow Length=350' Tc=18.2 min CN=79 Runoff=1.14 cfs 0.089 af

Subcatchment 4S: Prop. Area to Crosby Runoff Area=10,015 sf 0.00% Impervious Runoff Depth=1.22"
Flow Length=125' Slope=0.0100 '/' Tc=23.3 min CN=79 Runoff=0.27 cfs 0.023 af

Subcatchment 8S: Area Overland to North Runoff Area=51,085 sf 0.00% Impervious Runoff Depth=1.10"
Flow Length=140' Tc=11.7 min CN=77 Runoff=1.59 cfs 0.107 af

Subcatchment 10S: Area to CB#1 Runoff Area=19,240 sf 67.06% Impervious Runoff Depth=2.20"
Flow Length=80' Tc=12.8 min CN=92 Runoff=1.17 cfs 0.081 af

Subcatchment 12S: Area to CB#2 Runoff Area=12,315 sf 47.61% Impervious Runoff Depth=1.94"
Flow Length=80' Tc=12.8 min CN=89 Runoff=0.67 cfs 0.046 af

Subcatchment 14S: Area to CB#3 Runoff Area=18,345 sf 46.99% Impervious Runoff Depth=1.85"
Flow Length=260' Tc=19.1 min CN=88 Runoff=0.83 cfs 0.065 af

Subcatchment 18S: Area to YD#2 Runoff Area=27,200 sf 27.67% Impervious Runoff Depth=1.41"
Flow Length=140' Slope=0.0100 '/' Tc=23.4 min UI Adjusted CN=82 Runoff=0.86 cfs 0.073 af

Subcatchment 20S: Eastern Area Runoff Area=329,310 sf 62.48% Impervious Runoff Depth=2.11"
Flow Length=330' Tc=30.2 min CN=91 Runoff=13.16 cfs 1.328 af

Subcatchment 24S: Area to YD#11 Runoff Area=38,900 sf 53.89% Impervious Runoff Depth=2.02"
Flow Length=70' Slope=0.0100 '/' Tc=17.3 min CN=90 Runoff=1.95 cfs 0.150 af

Subcatchment 26S: Area to CB#4 Runoff Area=41,205 sf 62.20% Impervious Runoff Depth=2.11"
Flow Length=100' Tc=16.9 min CN=91 Runoff=2.15 cfs 0.166 af

Subcatchment 29S: Area to CB#15 Runoff Area=17,040 sf 100.00% Impervious Runoff Depth=2.81"
Tc=5.0 min CN=98 Runoff=1.36 cfs 0.092 af

Subcatchment 30S: Area to CB#18 Runoff Area=20,100 sf 15.05% Impervious Runoff Depth=1.34"
Flow Length=140' Slope=0.0100 '/' Tc=23.4 min UI Adjusted CN=81 Runoff=0.60 cfs 0.052 af

Subcatchment 32S: Area to CB#7 Runoff Area=36,220 sf 69.35% Impervious Runoff Depth=2.20"
Flow Length=100' Tc=16.9 min CN=92 Runoff=1.95 cfs 0.152 af

Subcatchment 36S: Area to CB#9 Runoff Area=18,475 sf 44.79% Impervious Runoff Depth=1.85"
Flow Length=80' Slope=0.0100 '/' Tc=19.3 min CN=88 Runoff=0.84 cfs 0.066 af

Plug Power - Proposed Conditions 5-15-21

Type II 24-hr 10-yr Rainfall=3.04"

Prepared by {enter your company name here}

Printed 5/20/2021

HydroCAD® 10.10-5a s/n 11585 © 2020 HydroCAD Software Solutions LLC

Page 86

Subcatchment 38S: Area to CB#10	Runoff Area=39,650 sf 16.97% Impervious Runoff Depth=1.48"
Flow Length=150'	Slope=0.0140 '/' Tc=20.6 min CN=83 Runoff=1.40 cfs 0.112 af
Subcatchment 40S: Area to CB#11	Runoff Area=31,495 sf 100.00% Impervious Runoff Depth=2.81"
Flow Length=170'	Slope=0.0120 '/' Tc=22.1 min CN=98 Runoff=1.86 cfs 0.169 af
Subcatchment 42S: Western Area	Runoff Area=139,665 sf 42.71% Impervious Runoff Depth=1.85"
Flow Length=50'	Slope=0.0200 '/' Tc=6.3 min CN=88 Runoff=8.69 cfs 0.495 af
Subcatchment 43S: North Half of Phase 2	Runoff Area=36,505 sf 100.00% Impervious Runoff Depth=2.81"
	Tc=5.0 min CN=98 Runoff=2.90 cfs 0.196 af
Subcatchment 45S: South Half of Phase	Runoff Area=32,290 sf 100.00% Impervious Runoff Depth=2.81"
	Tc=5.0 min CN=98 Runoff=2.57 cfs 0.173 af
Subcatchment 48S: Area to YD#1	Runoff Area=34,030 sf 37.80% Impervious Runoff Depth=1.77"
Flow Length=150'	Slope=0.0100 '/' Tc=23.6 min CN=87 Runoff=1.35 cfs 0.115 af
Subcatchment 49S: Area to YD#3	Runoff Area=81,835 sf 30.11% Impervious Runoff Depth=1.62"
Flow Length=340'	Tc=25.3 min CN=85 Runoff=2.84 cfs 0.254 af
Subcatchment 52S: Area Overland to	Runoff Area=71,325 sf 0.00% Impervious Runoff Depth=1.28"
Flow Length=30'	Tc=5.4 min CN=80 Runoff=3.09 cfs 0.175 af
Subcatchment 53S: Area Overland to	Runoff Area=5,925 sf 0.00% Impervious Runoff Depth=1.28"
	Tc=5.0 min CN=80 Runoff=0.25 cfs 0.015 af
Subcatchment 54S: Area Overland to	Runoff Area=6,040 sf 0.00% Impervious Runoff Depth=1.28"
	Tc=5.0 min CN=80 Runoff=0.26 cfs 0.015 af
Subcatchment 55S: Area Overland to	Runoff Area=13,210 sf 0.00% Impervious Runoff Depth=1.28"
Flow Length=25'	Slope=0.0100 '/' Tc=7.6 min CN=80 Runoff=0.57 cfs 0.032 af
Subcatchment 56S: Area Overland to Dry	Runoff Area=19,245 sf 0.00% Impervious Runoff Depth=1.28"
	Tc=5.0 min CN=80 Runoff=0.82 cfs 0.047 af
Subcatchment 57S: Area Overland to North	Runoff Area=23,585 sf 0.00% Impervious Runoff Depth=1.10"
Flow Length=100'	Tc=10.8 min CN=77 Runoff=0.77 cfs 0.050 af
Subcatchment 58S: Area Overland to North	Runoff Area=17,005 sf 0.00% Impervious Runoff Depth=1.10"
Flow Length=170'	Tc=14.9 min CN=77 Runoff=0.46 cfs 0.036 af
Reach 7R: Crosby Road Ditch	Avg. Flow Depth=0.10' Max Vel=0.93 fps Inflow=0.27 cfs 0.023 af
n=0.030 L=450.0' S=0.0089 '/'	Capacity=98.41 cfs Outflow=0.23 cfs 0.023 af
Reach 9R: North Property Line Ditch	Avg. Flow Depth=0.23' Max Vel=1.40 fps Inflow=1.68 cfs 0.131 af
n=0.030 L=670.0' S=0.0100 '/'	Capacity=634.40 cfs Outflow=1.39 cfs 0.131 af
Reach 23R: North Swale to	Avg. Flow Depth=2.02' Max Vel=0.39 fps Inflow=9.94 cfs 1.502 af
n=0.300 L=180.0' S=0.0050 '/'	Capacity=23.67 cfs Outflow=9.55 cfs 1.502 af

Plug Power - Proposed Conditions 5-15-21

Type II 24-hr 10-yr Rainfall=3.04"

Prepared by {enter your company name here}

Printed 5/20/2021

HydroCAD® 10.10-5a s/n 11585 © 2020 HydroCAD Software Solutions LLC

Page 87

Reach 25R: North Property Line Ditch	Avg. Flow Depth=0.40'	Max Vel=1.21 fps	Inflow=3.00 cfs	0.524 af
	n=0.030	L=500.0'	S=0.0040 '/'	Capacity=401.23 cfs
			Outflow=2.92 cfs	0.524 af
Reach 26R: North Property Line Ditch	Avg. Flow Depth=0.86'	Max Vel=1.45 fps	Inflow=12.94 cfs	4.286 af
	n=0.030	L=500.0'	S=0.0024 '/'	Capacity=310.79 cfs
			Outflow=13.22 cfs	4.286 af
Reach 27R: Swale to Dry Pond	Avg. Flow Depth=0.61'	Max Vel=1.85 fps	Inflow=9.03 cfs	0.297 af
x 2.00	n=0.030	L=130.0'	S=0.0050 '/'	Capacity=118.87 cfs
			Outflow=8.59 cfs	0.297 af
Reach 52R: West Swale to	Avg. Flow Depth=2.48'	Max Vel=0.44 fps	Inflow=16.08 cfs	2.050 af
	n=0.300	L=180.0'	S=0.0050 '/'	Capacity=23.67 cfs
			Outflow=15.25 cfs	2.050 af
Pond 11P: CB#1		Peak Elev=668.34'	Inflow=1.17 cfs	0.081 af
	12.0" Round Culvert	n=0.012	L=137.0'	S=0.0020 '/'
			Outflow=1.17 cfs	0.081 af
Pond 13P: CB#3		Peak Elev=668.27'	Inflow=1.84 cfs	0.127 af
	12.0" Round Culvert	n=0.012	L=213.0'	S=0.0020 '/'
			Outflow=1.84 cfs	0.127 af
Pond 15P: CB#5		Peak Elev=668.13'	Inflow=6.31 cfs	0.561 af
	24.0" Round Culvert	n=0.012	L=180.0'	S=0.0020 '/'
			Outflow=6.31 cfs	0.561 af
Pond 19P: YD#22		Peak Elev=667.24'	Storage=2 cf	Inflow=0.86 cfs
	10.0" Round Culvert	n=0.012	L=70.0'	S=0.0020 '/'
			Outflow=0.86 cfs	0.073 af
Pond 21P: Subsurface Detention within	Peak Elev=667.00'	Storage=8,593 cf	Inflow=36.97 cfs	3.787 af
Primary=15.88 cfs	2.036 af	Secondary=9.85 cfs	1.487 af	Tertiary=8.89 cfs
			0.264 af	Outflow=33.48 cfs
				3.787 af
Pond 22P: Bio-Retention Area	Peak Elev=664.34'	Storage=71,144 cf	Inflow=25.24 cfs	3.726 af
Primary=10.54 cfs	3.727 af	Secondary=0.00 cfs	0.000 af	Outflow=10.54 cfs
				3.727 af
Pond 25P: YD#11		Peak Elev=667.92'	Storage=2 cf	Inflow=1.95 cfs
	12.0" Round Culvert	n=0.012	L=170.0'	S=0.0020 '/'
			Outflow=1.95 cfs	0.150 af
Pond 27P: CB#4		Peak Elev=667.65'	Storage=7 cf	Inflow=2.15 cfs
	12.0" Round Culvert	n=0.012	L=40.0'	S=0.0020 '/'
			Outflow=2.14 cfs	0.166 af
Pond 28P: CB#15		Peak Elev=667.61'	Storage=7 cf	Inflow=4.95 cfs
	18.0" Round Culvert	n=0.012	L=157.0'	S=0.0020 '/'
			Outflow=4.95 cfs	0.408 af
Pond 29P: Dry Pond	Peak Elev=663.98'	Storage=9,956 cf	Inflow=8.74 cfs	0.344 af
Primary=2.08 cfs	0.344 af	Tertiary=0.00 cfs	0.000 af	Outflow=2.08 cfs
				0.344 af
Pond 31P: CB#18		Peak Elev=667.52'	Storage=8 cf	Inflow=5.37 cfs
	18.0" Round Culvert	n=0.012	L=83.0'	S=0.0020 '/'
			Outflow=5.37 cfs	0.460 af
Pond 33P: CB#26		Peak Elev=667.09'	Storage=7 cf	Inflow=1.95 cfs
	12.0" Round Culvert	n=0.012	L=175.0'	S=0.0020 '/'
			Outflow=1.95 cfs	0.152 af
Pond 37P: CB#28		Peak Elev=667.08'	Storage=8 cf	Inflow=2.78 cfs
	15.0" Round Culvert	n=0.012	L=214.0'	S=0.0020 '/'
			Outflow=2.78 cfs	0.218 af

Plug Power - Proposed Conditions 5-15-21

Type II 24-hr 10-yr Rainfall=3.04"

Prepared by {enter your company name here}

Printed 5/20/2021

HydroCAD® 10.10-5a s/n 11585 © 2020 HydroCAD Software Solutions LLC

Page 88

Pond 39P: CB#30 Peak Elev=667.07' Storage=10 cf Inflow=4.16 cfs 0.330 af
18.0" Round Culvert n=0.012 L=150.0' S=0.0020 '/ Outflow=4.16 cfs 0.330 af

Pond 41P: CB#32 Peak Elev=667.04' Storage=11 cf Inflow=6.01 cfs 0.499 af
24.0" Round Culvert n=0.012 L=166.0' S=0.0020 '/ Outflow=6.01 cfs 0.499 af

Pond 44P: CB#24 Peak Elev=667.09' Inflow=10.87 cfs 0.903 af
24.0" Round Culvert n=0.012 L=105.0' S=0.0020 '/ Outflow=10.87 cfs 0.903 af

Pond 46P: CB#20 Peak Elev=667.33' Inflow=7.61 cfs 0.633 af
24.0" Round Culvert n=0.012 L=157.0' S=0.0020 '/ Outflow=7.61 cfs 0.633 af

Pond 50P: YD#8 Peak Elev=668.45' Storage=1 cf Inflow=4.19 cfs 0.369 af
18.0" Round Culvert n=0.012 L=122.0' S=0.0020 '/ Outflow=4.19 cfs 0.369 af

Pond 51P: YD#6 Peak Elev=668.65' Storage=1 cf Inflow=2.84 cfs 0.254 af
15.0" Round Culvert n=0.012 L=138.0' S=0.0020 '/ Outflow=2.84 cfs 0.254 af

Link 52L: Total Site Discharge Inflow=13.50 cfs 4.464 af
Primary=13.50 cfs 4.464 af

Total Runoff Area = 29.096 ac Runoff Volume = 4.464 af Average Runoff Depth = 1.84"
57.01% Pervious = 16.587 ac 42.99% Impervious = 12.509 ac

Plug Power - Proposed Conditions 5-15-21

Type II 24-hr 10-yr Rainfall=3.04"

Prepared by {enter your company name here}

Printed 5/20/2021

HydroCAD® 10.10-5a s/n 11585 © 2020 HydroCAD Software Solutions LLC

Page 89

Summary for Subcatchment 1S: Prop. Area to SW Property Line (Wetland)

Runoff = 0.73 cfs @ 12.15 hrs, Volume= 0.059 af, Depth= 1.22"

Runoff by SCS TR-20 method, UH=SCS, Weighted-CN, Time Span= 0.00-48.00 hrs, dt= 0.15 hrs
Type II 24-hr 10-yr Rainfall=3.04"

Area (sf)	CN	Description
5,020	78	Meadow, non-grazed, HSG D
18,430	79	Woods, Fair, HSG D
2,045	80	>75% Grass cover, Good, HSG D
25,495	79	Weighted Average
25,495		100.00% Pervious Area

Tc (min)	Length (feet)	Slope (ft/ft)	Velocity (ft/sec)	Capacity (cfs)	Description
2.8	10	0.0200	0.06		Sheet Flow, 10' Overland Flow Grass: Dense n= 0.240 P2= 2.14"
5.1	40	0.0200	0.13		Sheet Flow, 40' Overland Flow Range n= 0.130 P2= 2.14"
12.6	40	0.0200	0.05		Sheet Flow, 40' Overland Flow Woods: Light underbrush n= 0.400 P2= 2.14"
20.5	90	Total			

Subcatchment 1S: Prop. Area to SW Property Line (Wetland)

Hydrograph

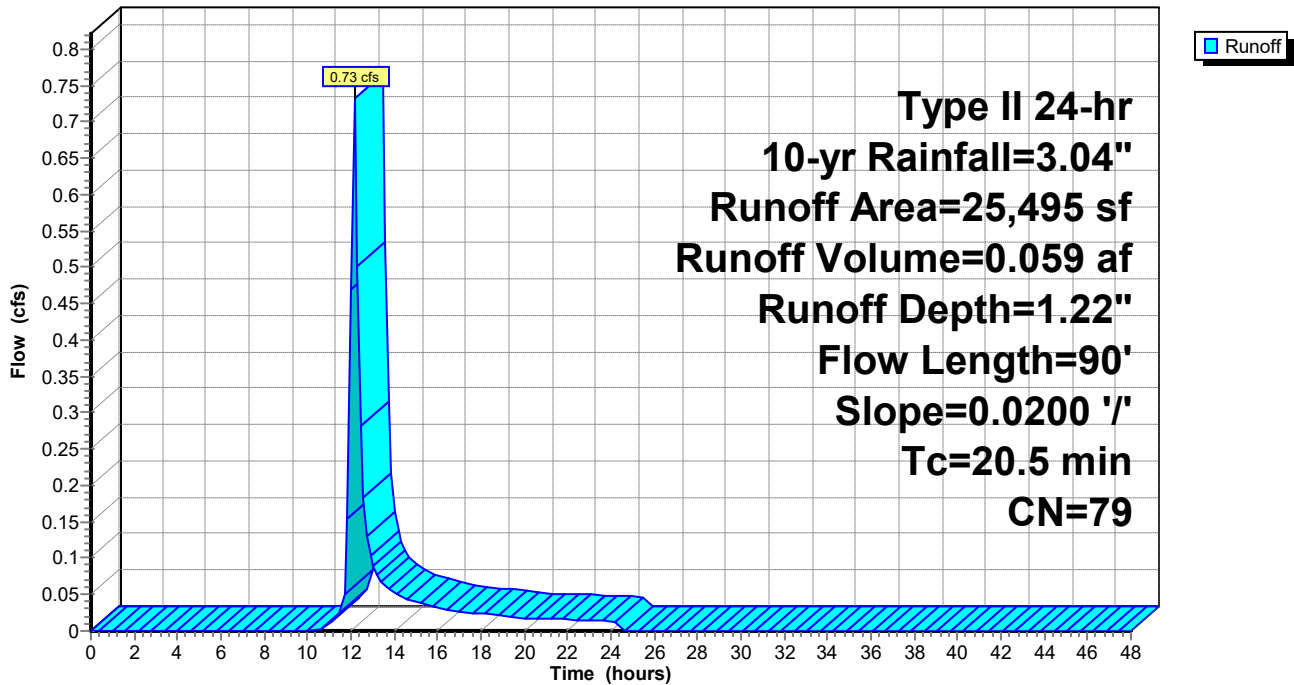

Plug Power - Proposed Conditions 5-15-21

Type II 24-hr 10-yr Rainfall=3.04"

Prepared by {enter your company name here}

Printed 5/20/2021

HydroCAD® 10.10-5a s/n 11585 © 2020 HydroCAD Software Solutions LLC

Page 90

Summary for Subcatchment 2S: Prop. Area to SE Property Line

Runoff = 0.37 cfs @ 12.15 hrs, Volume= 0.029 af, Depth= 1.22"

Runoff by SCS TR-20 method, UH=SCS, Weighted-CN, Time Span= 0.00-48.00 hrs, dt= 0.15 hrs
Type II 24-hr 10-yr Rainfall=3.04"

Area (sf)	CN	Description
12,470	79	Woods/grass comb., Good, HSG D
12,470		100.00% Pervious Area

Tc (min)	Length (feet)	Slope (ft/ft)	Velocity (ft/sec)	Capacity (cfs)	Description
19.6	100	0.0150	0.09		Sheet Flow, 100' Overland Flow Grass: Dense n= 0.240 P2= 2.14"

Subcatchment 2S: Prop. Area to SE Property Line

Hydrograph

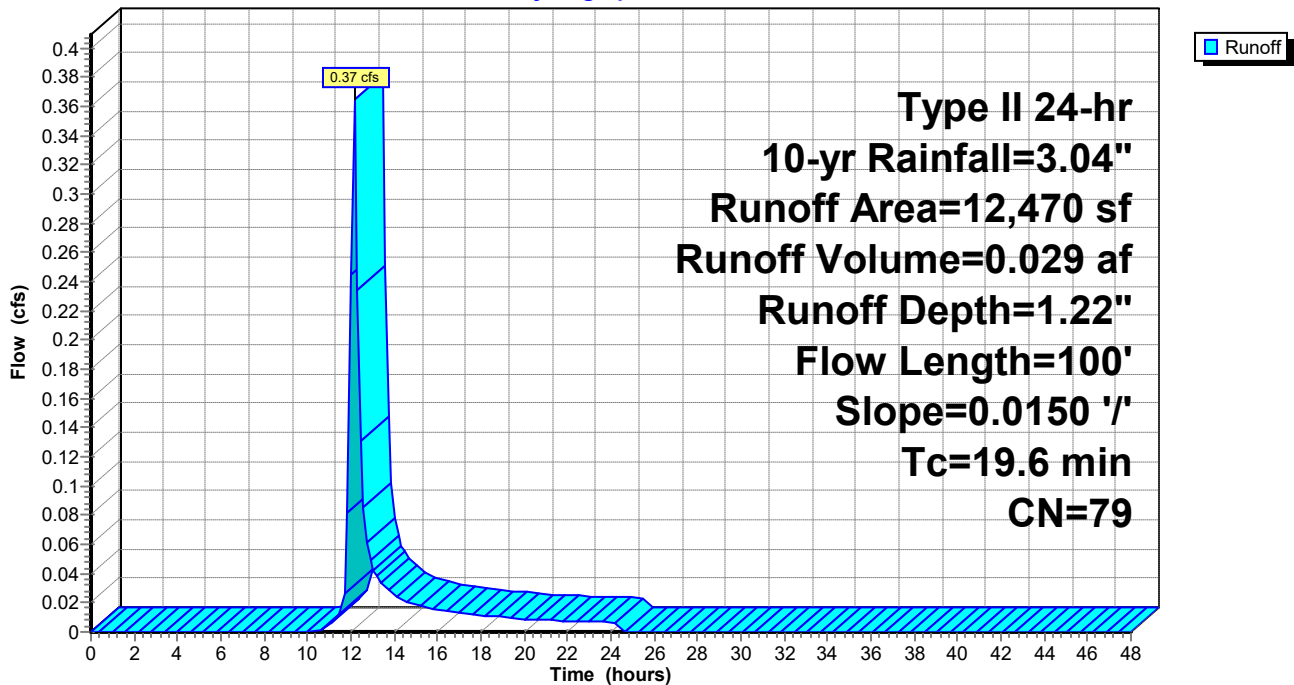

Plug Power - Proposed Conditions 5-15-21

Type II 24-hr 10-yr Rainfall=3.04"

Prepared by {enter your company name here}

Printed 5/20/2021

HydroCAD® 10.10-5a s/n 11585 © 2020 HydroCAD Software Solutions LLC

Page 91

Summary for Subcatchment 3S: Prop. Area to West Property Line (Wetland)

Runoff = 1.14 cfs @ 12.13 hrs, Volume= 0.089 af, Depth= 1.22"

Runoff by SCS TR-20 method, UH=SCS, Weighted-CN, Time Span= 0.00-48.00 hrs, dt= 0.15 hrs
Type II 24-hr 10-yr Rainfall=3.04"

Area (sf)	CN	Description
20,080	80	>75% Grass cover, Good, HSG D
18,110	78	Meadow, non-grazed, HSG D
38,190	79	Weighted Average
38,190		100.00% Pervious Area

Tc (min)	Length (feet)	Slope (ft/ft)	Velocity (ft/sec)	Capacity (cfs)	Description
16.0	100	0.0250	0.10		Sheet Flow, 100' Overland Flow Grass: Dense n= 0.240 P2= 2.14"
2.2	250	0.0160	1.90		Shallow Concentrated Flow, 250' Shallow Conc. Flow Grassed Waterway Kv= 15.0 fps
18.2	350	Total			

Subcatchment 3S: Prop. Area to West Property Line (Wetland)

Hydrograph

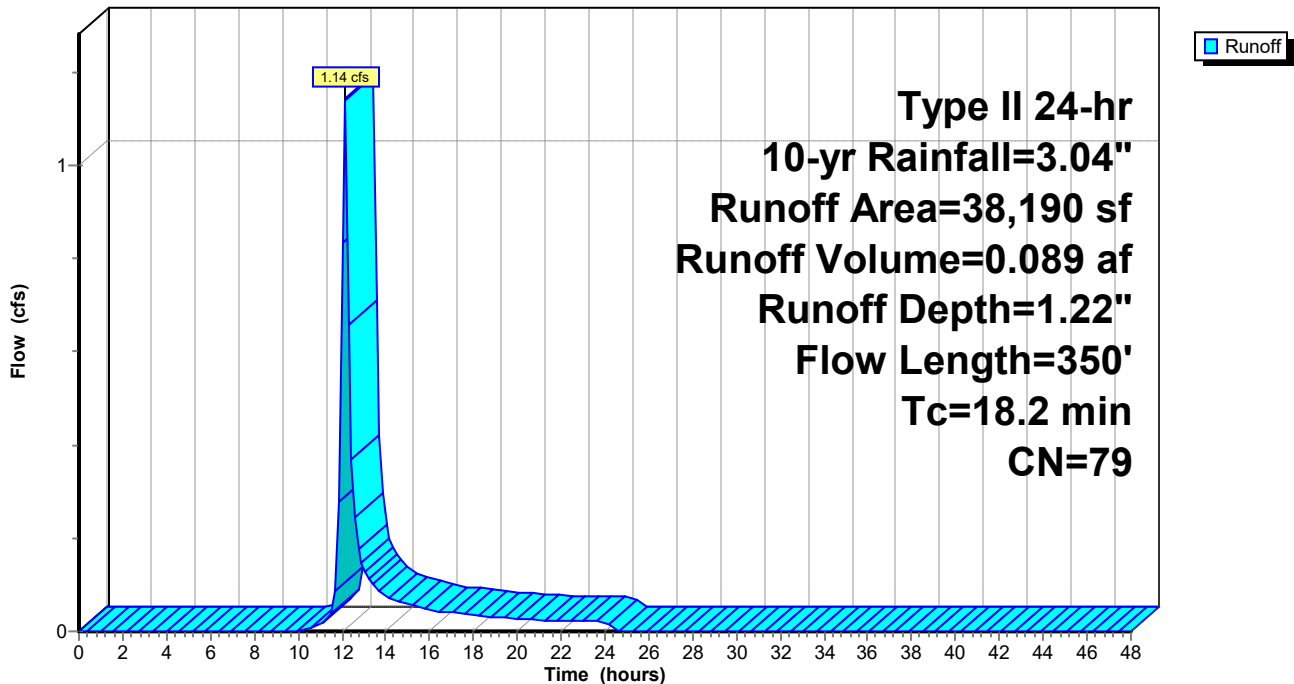

Plug Power - Proposed Conditions 5-15-21

Type II 24-hr 10-yr Rainfall=3.04"

Prepared by {enter your company name here}

Printed 5/20/2021

HydroCAD® 10.10-5a s/n 11585 © 2020 HydroCAD Software Solutions LLC

Page 92

Summary for Subcatchment 4S: Prop. Area to Crosby Road Ditch

Runoff = 0.27 cfs @ 12.18 hrs, Volume= 0.023 af, Depth= 1.22"

Runoff by SCS TR-20 method, UH=SCS, Weighted-CN, Time Span= 0.00-48.00 hrs, dt= 0.15 hrs
Type II 24-hr 10-yr Rainfall=3.04"

Area (sf)	CN	Description
10,015	79	Woods/grass comb., Good, HSG D
10,015		100.00% Pervious Area

Tc (min)	Length (feet)	Slope (ft/ft)	Velocity (ft/sec)	Capacity (cfs)	Description
23.0	100	0.0100	0.07		Sheet Flow, 100' Overland Flow Grass: Dense n= 0.240 P2= 2.14"
0.3	25	0.0100	1.50		Shallow Concentrated Flow, 25' Shallow Conc. Flow Grassed Waterway Kv= 15.0 fps
23.3	125	Total			

Subcatchment 4S: Prop. Area to Crosby Road Ditch

Hydrograph

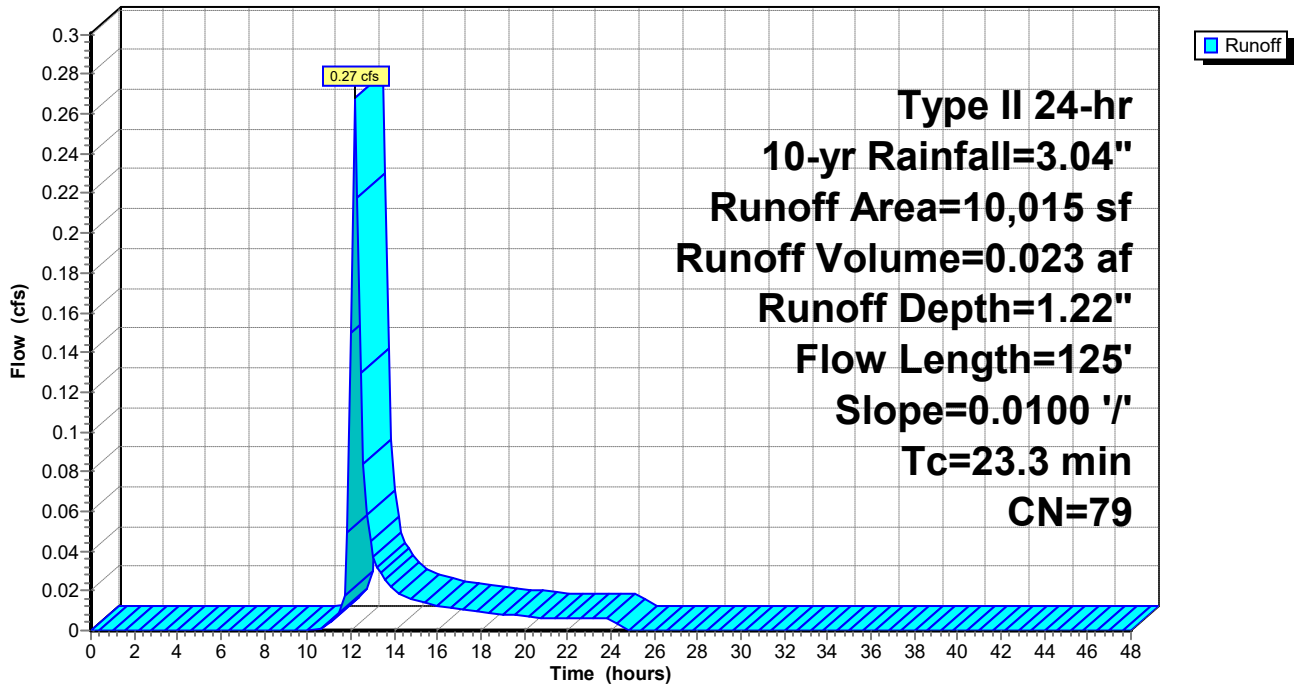

Plug Power - Proposed Conditions 5-15-21

Type II 24-hr 10-yr Rainfall=3.04"

Prepared by {enter your company name here}

Printed 5/20/2021

HydroCAD® 10.10-5a s/n 11585 © 2020 HydroCAD Software Solutions LLC

Page 93

Summary for Subcatchment 8S: Area Overland to North Prop. Line and Wetland Ditch (East)

Runoff = 1.59 cfs @ 12.03 hrs, Volume= 0.107 af, Depth= 1.10"

Runoff by SCS TR-20 method, UH=SCS, Weighted-CN, Time Span= 0.00-48.00 hrs, dt= 0.15 hrs
Type II 24-hr 10-yr Rainfall=3.04"

Area (sf)	CN	Description
51,085	77	Brush, Fair, HSG D
51,085		100.00% Pervious Area

Tc (min)	Length (feet)	Slope (ft/ft)	Velocity (ft/sec)	Capacity (cfs)	Description
10.7	100	0.0200	0.16		Sheet Flow, 100' Overland Flow Range n= 0.130 P2= 2.14"
1.0	40	0.0100	0.70		Shallow Concentrated Flow, 40' Shallow Conc. Flow Short Grass Pasture Kv= 7.0 fps
11.7	140	Total			

Subcatchment 8S: Area Overland to North Prop. Line and Wetland Ditch (East)

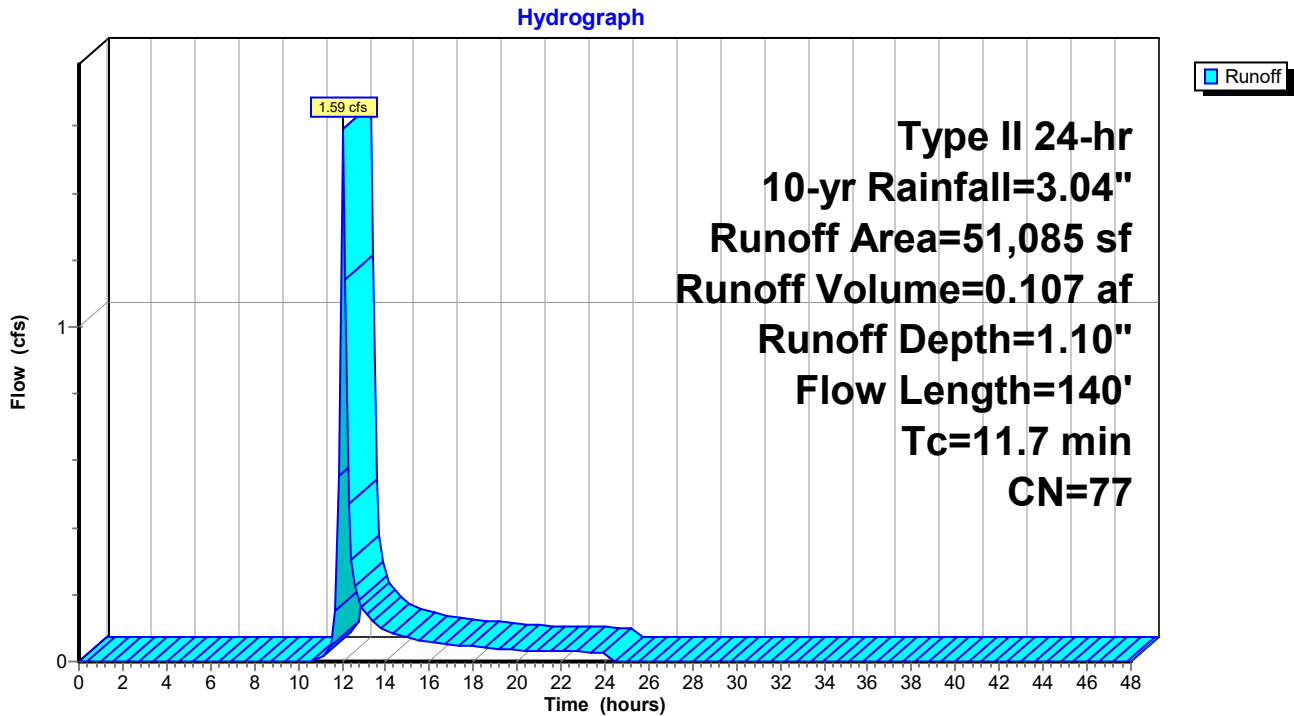

Plug Power - Proposed Conditions 5-15-21

Type II 24-hr 10-yr Rainfall=3.04"

Prepared by {enter your company name here}

Printed 5/20/2021

HydroCAD® 10.10-5a s/n 11585 © 2020 HydroCAD Software Solutions LLC

Page 94

Summary for Subcatchment 10S: Area to CB#1

Runoff = 1.17 cfs @ 12.03 hrs, Volume= 0.081 af, Depth= 2.20"

Runoff by SCS TR-20 method, UH=SCS, Weighted-CN, Time Span= 0.00-48.00 hrs, dt= 0.15 hrs
Type II 24-hr 10-yr Rainfall=3.04"

Area (sf)	CN	Description
4,063	98	Roofs, HSG D
8,840	98	Paved parking, HSG D
6,337	80	>75% Grass cover, Good, HSG D
19,240	92	Weighted Average
6,337		32.94% Pervious Area
12,903		67.06% Impervious Area

Tc (min)	Length (feet)	Slope (ft/ft)	Velocity (ft/sec)	Capacity (cfs)	Description
12.4	65	0.0200	0.09		Sheet Flow, 65' Overland Flow Grass: Dense n= 0.240 P2= 2.14"
0.4	15	0.0100	0.58		Sheet Flow, 15' Overland Flow Smooth surfaces n= 0.011 P2= 2.14"
12.8	80	Total			

Subcatchment 10S: Area to CB#1

Hydrograph

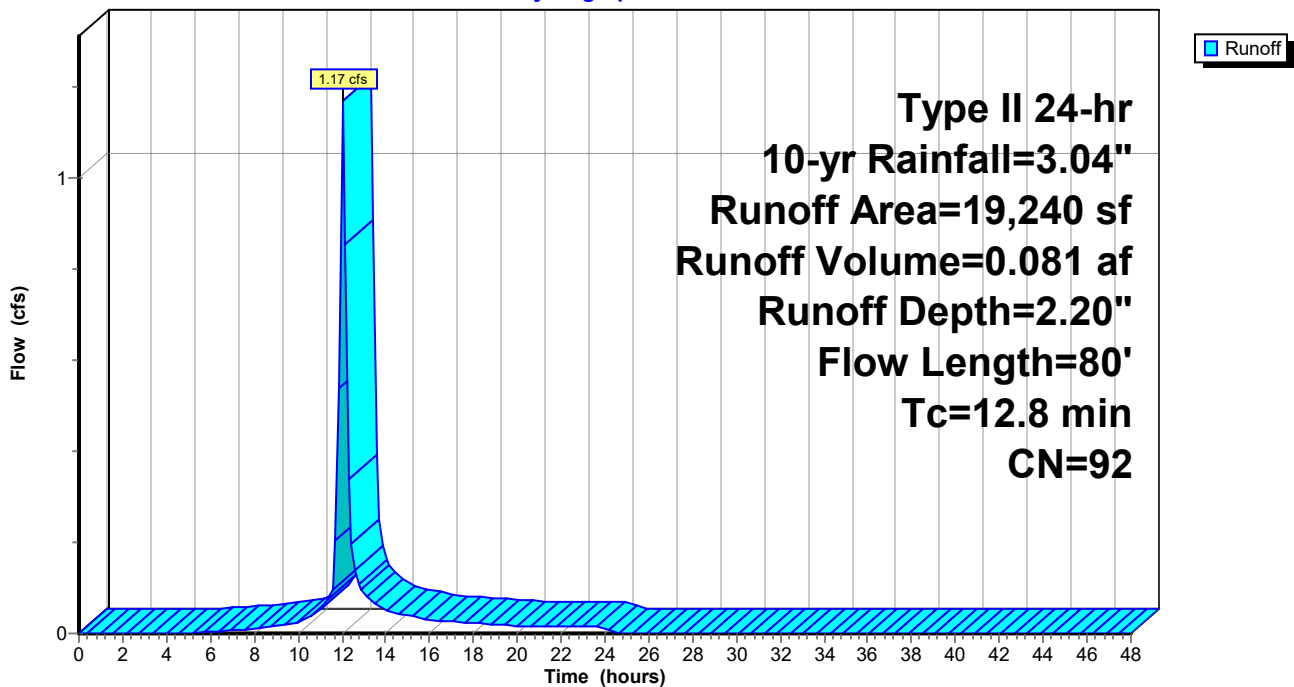

Plug Power - Proposed Conditions 5-15-21

Type II 24-hr 10-yr Rainfall=3.04"

Prepared by {enter your company name here}

Printed 5/20/2021

HydroCAD® 10.10-5a s/n 11585 © 2020 HydroCAD Software Solutions LLC

Page 95

Summary for Subcatchment 12S: Area to CB#2

Runoff = 0.67 cfs @ 12.03 hrs, Volume= 0.046 af, Depth= 1.94"

Runoff by SCS TR-20 method, UH=SCS, Weighted-CN, Time Span= 0.00-48.00 hrs, dt= 0.15 hrs
Type II 24-hr 10-yr Rainfall=3.04"

Area (sf)	CN	Description
4,063	98	Roofs, HSG D
1,800	98	Paved parking, HSG D
6,452	80	>75% Grass cover, Good, HSG D
12,315	89	Weighted Average
6,452		52.39% Pervious Area
5,863		47.61% Impervious Area

Tc (min)	Length (feet)	Slope (ft/ft)	Velocity (ft/sec)	Capacity (cfs)	Description
12.4	65	0.0200	0.09		Sheet Flow, 65' Overland Flow Grass: Dense n= 0.240 P2= 2.14"
0.4	15	0.0100	0.58		Sheet Flow, 15' Overland Flow Smooth surfaces n= 0.011 P2= 2.14"
12.8	80	Total			

Subcatchment 12S: Area to CB#2

Hydrograph

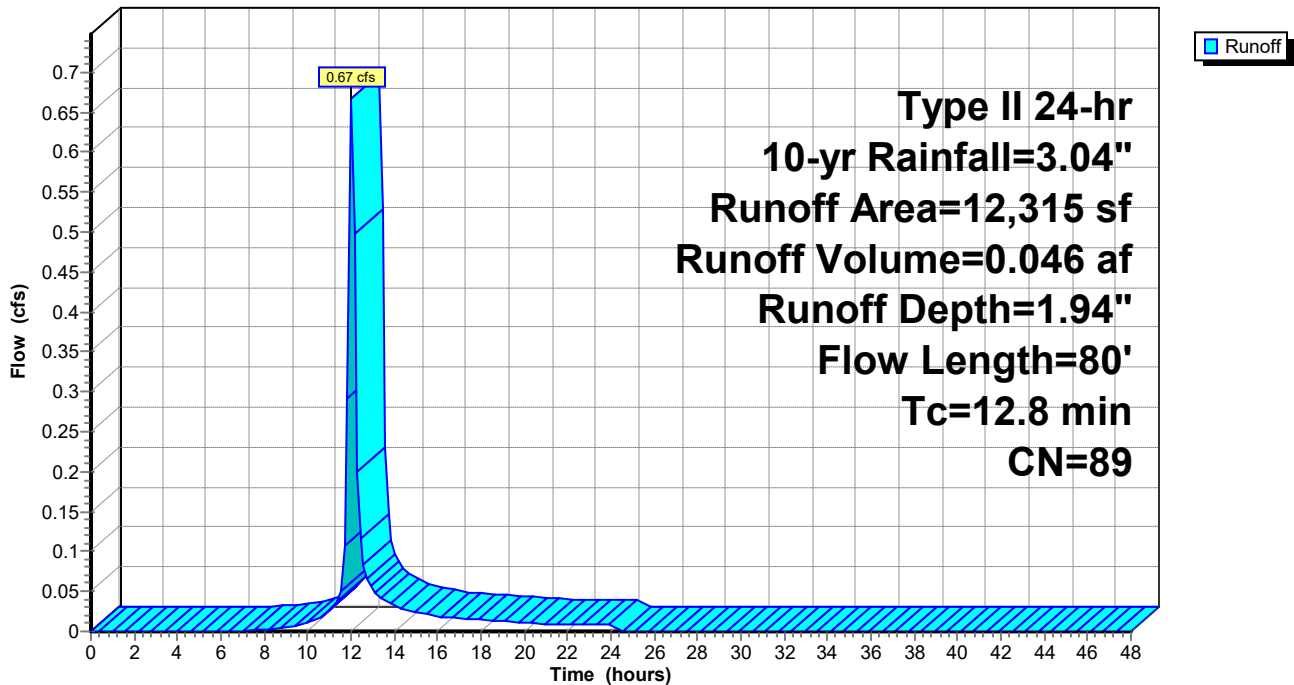

Plug Power - Proposed Conditions 5-15-21

Type II 24-hr 10-yr Rainfall=3.04"

Prepared by {enter your company name here}

Printed 5/20/2021

HydroCAD® 10.10-5a s/n 11585 © 2020 HydroCAD Software Solutions LLC

Page 96

Summary for Subcatchment 14S: Area to CB#3

Runoff = 0.83 cfs @ 12.13 hrs, Volume= 0.065 af, Depth= 1.85"

Runoff by SCS TR-20 method, UH=SCS, Weighted-CN, Time Span= 0.00-48.00 hrs, dt= 0.15 hrs
Type II 24-hr 10-yr Rainfall=3.04"

Area (sf)	CN	Description
8,620	98	Paved parking, HSG D
9,725	80	>75% Grass cover, Good, HSG D
18,345	88	Weighted Average
9,725		53.01% Pervious Area
8,620		46.99% Impervious Area

Tc (min)	Length (feet)	Slope (ft/ft)	Velocity (ft/sec)	Capacity (cfs)	Description
17.5	100	0.0200	0.10		Sheet Flow, 100' Overland Flow Grass: Dense n= 0.240 P2= 2.14"
1.4	130	0.0100	1.50		Shallow Concentrated Flow, 130' Shallow Conc. Flow Grassed Waterway Kv= 15.0 fps
0.2	30	0.0200	2.87		Shallow Concentrated Flow, 30' Shallow Conc. Flow Paved Kv= 20.3 fps
19.1	260	Total			

Subcatchment 14S: Area to CB#3

Hydrograph

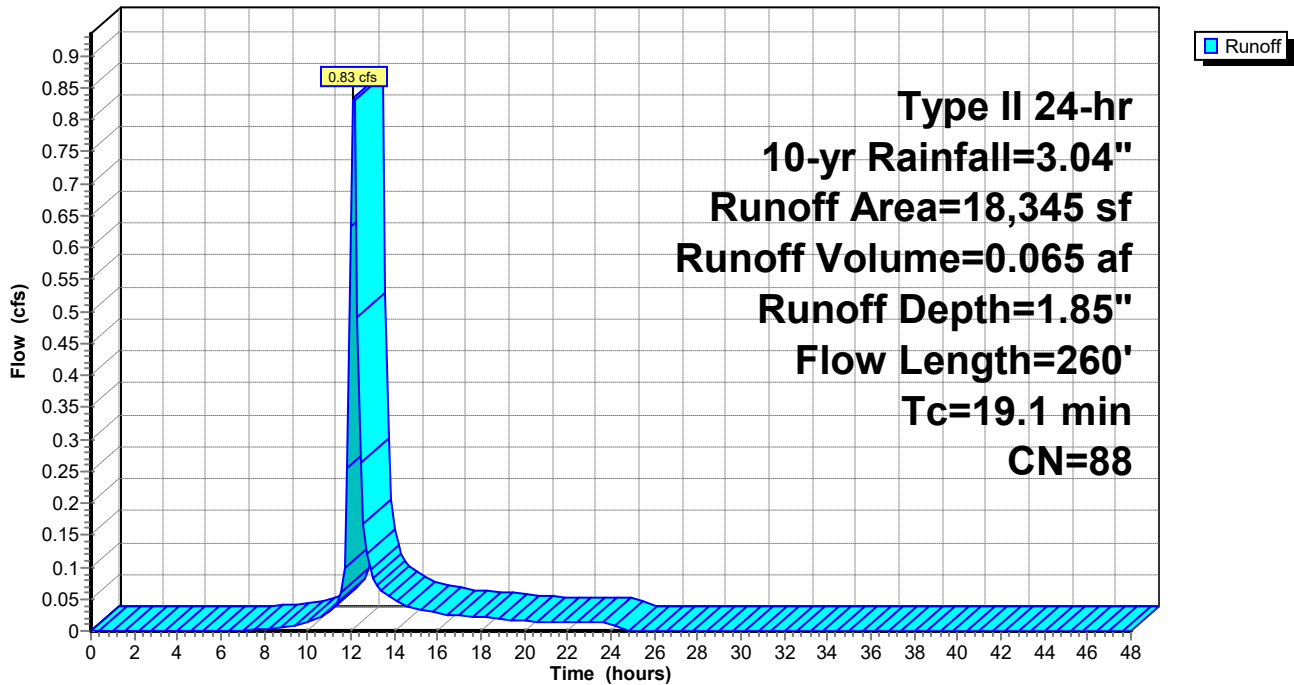

Plug Power - Proposed Conditions 5-15-21

Type II 24-hr 10-yr Rainfall=3.04"

Prepared by {enter your company name here}

Printed 5/20/2021

HydroCAD® 10.10-5a s/n 11585 © 2020 HydroCAD Software Solutions LLC

Page 97

Summary for Subcatchment 18S: Area to YD#2

Runoff = 0.86 cfs @ 12.18 hrs, Volume= 0.073 af, Depth= 1.41"

Runoff by SCS TR-20 method, UH=SCS, Weighted-CN, Time Span= 0.00-48.00 hrs, dt= 0.15 hrs
Type II 24-hr 10-yr Rainfall=3.04"

Area (sf)	CN	Adj	Description
19,675	80		>75% Grass cover, Good, HSG D
7,525	98		Unconnected pavement, HSG D
27,200	85	82	Weighted Average, UI Adjusted
19,675			72.33% Pervious Area
7,525			27.67% Impervious Area
7,525			100.00% Unconnected

Tc (min)	Length (feet)	Slope (ft/ft)	Velocity (ft/sec)	Capacity (cfs)	Description
23.0	100	0.0100	0.07		Sheet Flow, 100' Overland Flow
					Grass: Dense n= 0.240 P2= 2.14"
0.4	40	0.0100	1.50		Shallow Concentrated Flow, 40' Shallow Conc. Flow
					Grassed Waterway Kv= 15.0 fps
23.4	140	Total			

Subcatchment 18S: Area to YD#2

Hydrograph

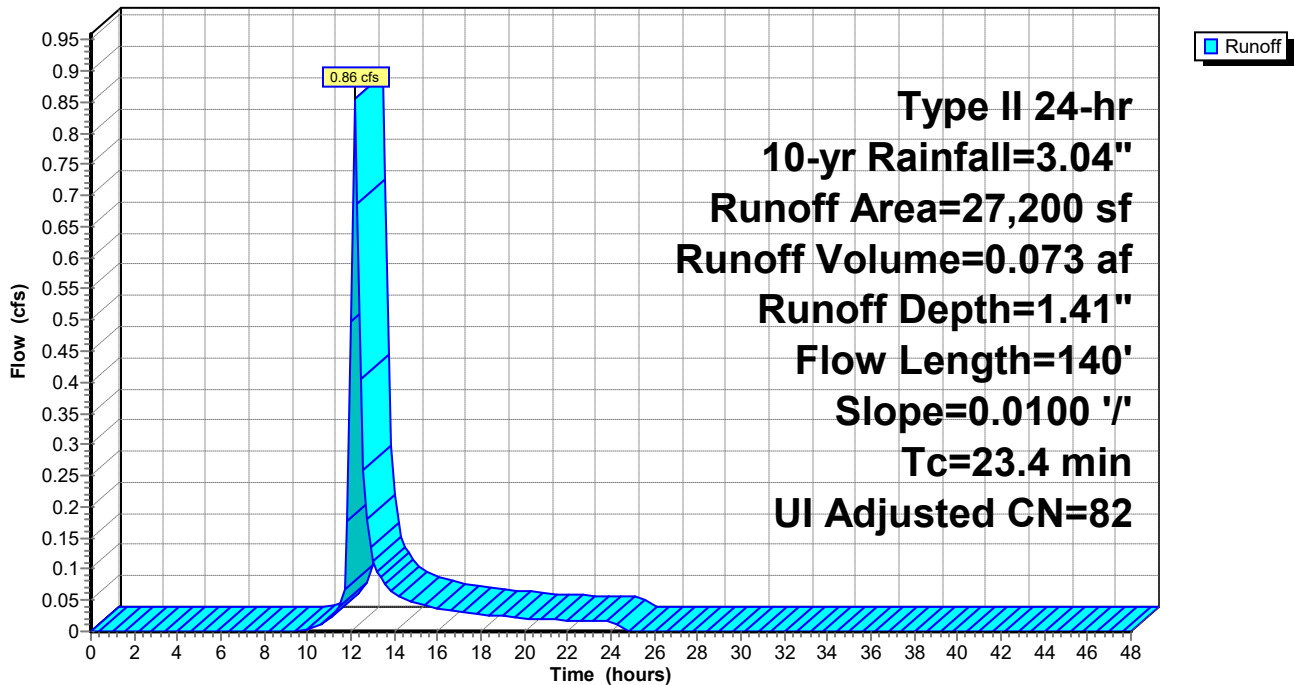

Plug Power - Proposed Conditions 5-15-21

Type II 24-hr 10-yr Rainfall=3.04"

Prepared by {enter your company name here}

Printed 5/20/2021

HydroCAD® 10.10-5a s/n 11585 © 2020 HydroCAD Software Solutions LLC

Page 98

Summary for Subcatchment 20S: Eastern Area Overland to Gravel Storage

Runoff = 13.16 cfs @ 12.25 hrs, Volume= 1.328 af, Depth= 2.11"

Runoff by SCS TR-20 method, UH=SCS, Weighted-CN, Time Span= 0.00-48.00 hrs, dt= 0.15 hrs
Type II 24-hr 10-yr Rainfall=3.04"

Area (sf)	CN	Description
* 77,480	80	Gravel Storage Area, Good, HSG D
80,190	98	Paved parking, HSG D
77,985	98	Roofs, HSG D
47,575	98	Unconnected pavement, HSG D
46,080	80	>75% Grass cover, Good, HSG D
329,310	91	Weighted Average
123,560		37.52% Pervious Area
205,750		62.48% Impervious Area
47,575		23.12% Unconnected

Tc (min)	Length (feet)	Slope (ft/ft)	Velocity (ft/sec)	Capacity (cfs)	Description
16.5	75	0.0130	0.08		Sheet Flow, 75' Overland Flow Grass: Dense n= 0.240 P2= 2.14"
12.3	25	0.0030	0.03		Sheet Flow, 25' Overland Flow Grass: Dense n= 0.240 P2= 2.14"
0.2	30	0.0300	2.60		Shallow Concentrated Flow, 30' Shallow Conc. Flow Grassed Waterway Kv= 15.0 fps
1.2	200	0.0200	2.87		Shallow Concentrated Flow, 200' Shallow Conc. Flow Paved Kv= 20.3 fps
30.2	330	Total			

Subcatchment 20S: Eastern Area Overland to Gravel Storage

Hydrograph

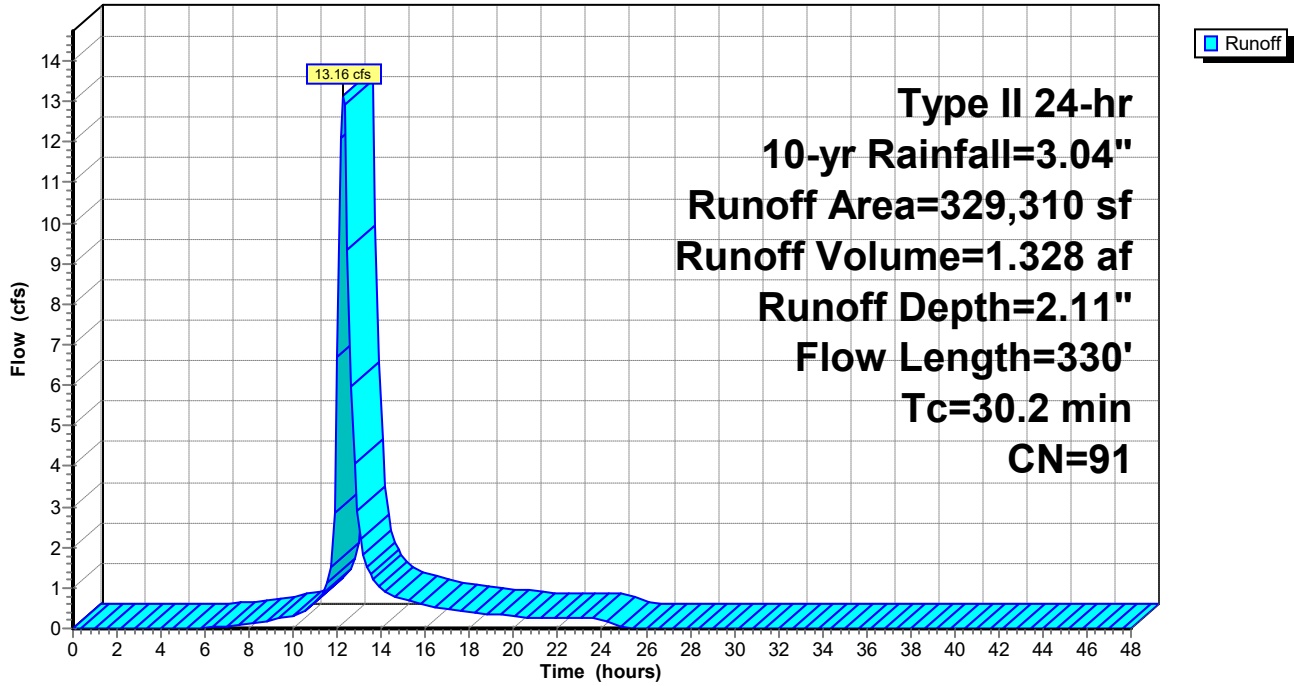

Plug Power - Proposed Conditions 5-15-21

Type II 24-hr 10-yr Rainfall=3.04"

Prepared by {enter your company name here}

Printed 5/20/2021

HydroCAD® 10.10-5a s/n 11585 © 2020 HydroCAD Software Solutions LLC

Page 100

Summary for Subcatchment 24S: Area to YD#11

Runoff = 1.95 cfs @ 12.11 hrs, Volume= 0.150 af, Depth= 2.02"

Runoff by SCS TR-20 method, UH=SCS, Weighted-CN, Time Span= 0.00-48.00 hrs, dt= 0.15 hrs
Type II 24-hr 10-yr Rainfall=3.04"

Area (sf)	CN	Description
3,925	98	Paved parking, HSG D
17,935	80	>75% Grass cover, Good, HSG D
17,040	98	Roofs, HSG D
38,900	90	Weighted Average
17,935		46.11% Pervious Area
20,965		53.89% Impervious Area

Tc (min)	Length (feet)	Slope (ft/ft)	Velocity (ft/sec)	Capacity (cfs)	Description
17.3	70	0.0100	0.07		Sheet Flow, 70' Overland Flow Grass: Dense n= 0.240 P2= 2.14"

Subcatchment 24S: Area to YD#11

Hydrograph

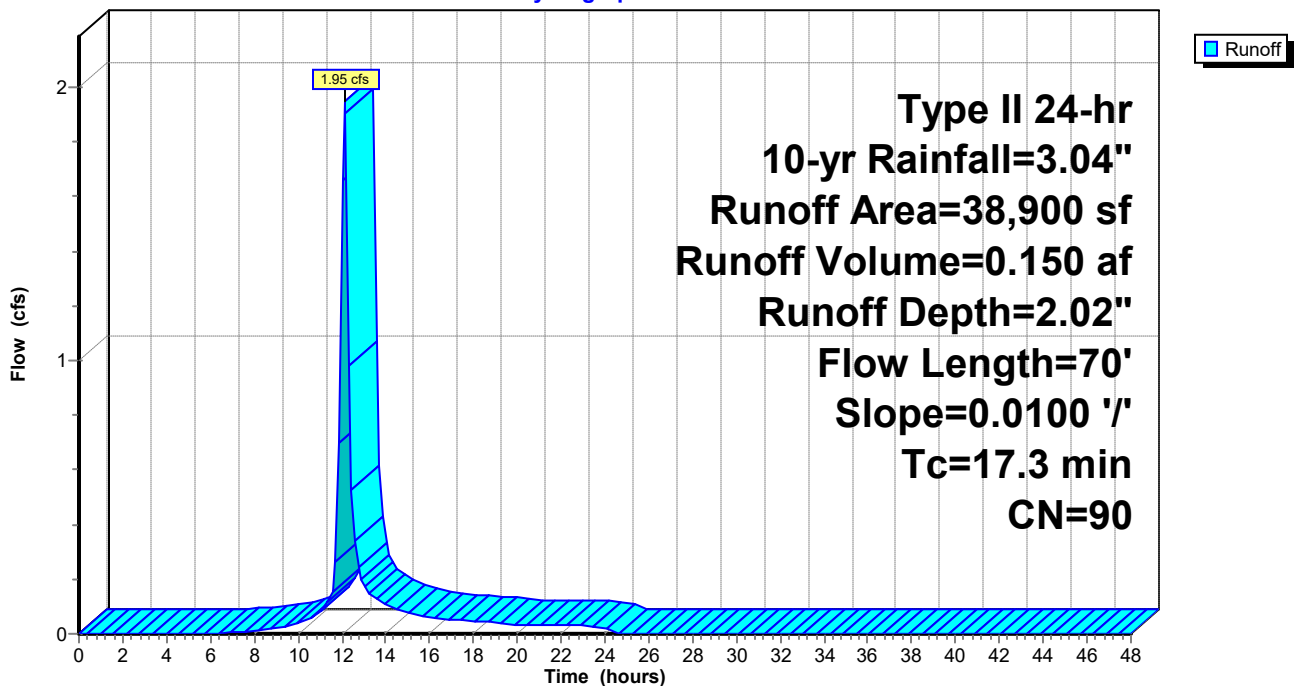

Plug Power - Proposed Conditions 5-15-21

Type II 24-hr 10-yr Rainfall=3.04"

Prepared by {enter your company name here}

Printed 5/20/2021

HydroCAD® 10.10-5a s/n 11585 © 2020 HydroCAD Software Solutions LLC

Page 101

Summary for Subcatchment 26S: Area to CB#4

Runoff = 2.15 cfs @ 12.10 hrs, Volume= 0.166 af, Depth= 2.11"

Runoff by SCS TR-20 method, UH=SCS, Weighted-CN, Time Span= 0.00-48.00 hrs, dt= 0.15 hrs
Type II 24-hr 10-yr Rainfall=3.04"

Area (sf)	CN	Description
510	98	Roofs, HSG D
25,120	98	Paved parking, HSG D
15,575	80	>75% Grass cover, Good, HSG D
41,205	91	Weighted Average
15,575		37.80% Pervious Area
25,630		62.20% Impervious Area

Tc (min)	Length (feet)	Slope (ft/ft)	Velocity (ft/sec)	Capacity (cfs)	Description
16.3	65	0.0100	0.07		Sheet Flow, 65' Overland Flow Grass: Dense n= 0.240 P2= 2.14"
0.6	35	0.0200	0.91		Sheet Flow, 35' Overland Flow Smooth surfaces n= 0.011 P2= 2.14"
16.9	100	Total			

Subcatchment 26S: Area to CB#4

Hydrograph

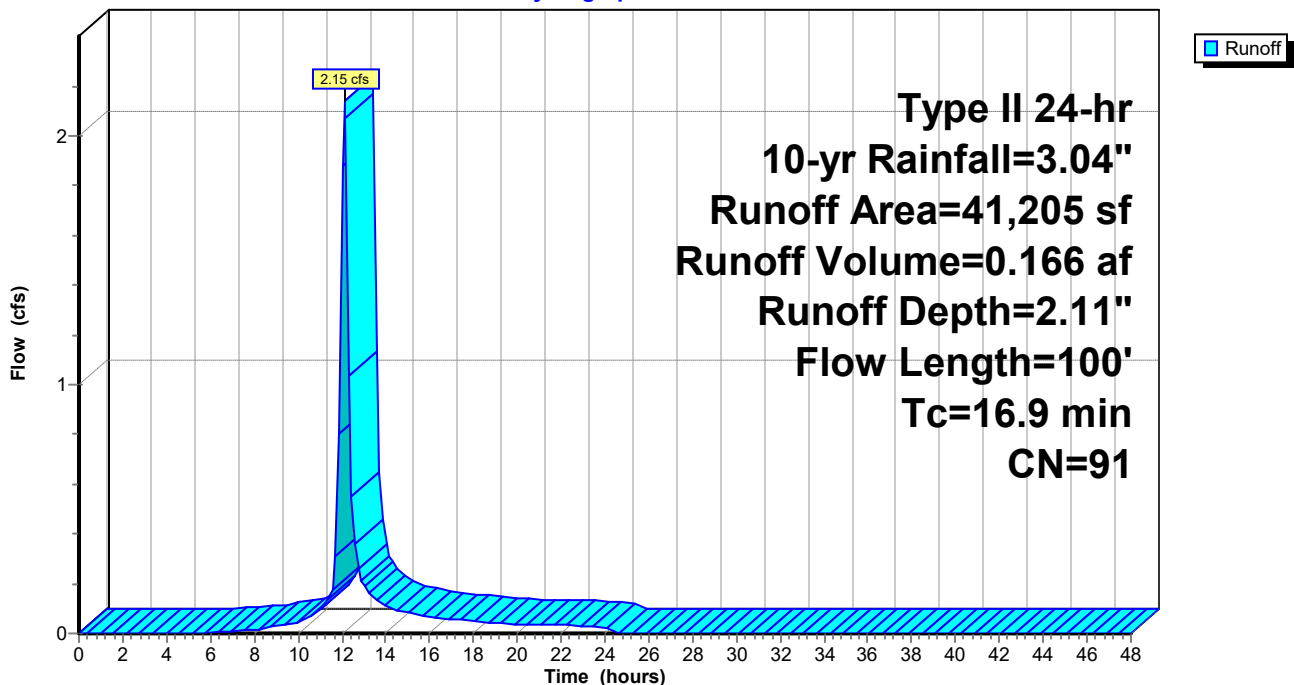

Plug Power - Proposed Conditions 5-15-21

Type II 24-hr 10-yr Rainfall=3.04"

Prepared by {enter your company name here}

Printed 5/20/2021

HydroCAD® 10.10-5a s/n 11585 © 2020 HydroCAD Software Solutions LLC

Page 102

Summary for Subcatchment 29S: Area to CB#15

Runoff = 1.36 cfs @ 11.95 hrs, Volume= 0.092 af, Depth= 2.81"

Runoff by SCS TR-20 method, UH=SCS, Weighted-CN, Time Span= 0.00-48.00 hrs, dt= 0.15 hrs
Type II 24-hr 10-yr Rainfall=3.04"

Area (sf)	CN	Description
17,040	98	Roofs, HSG D
17,040		100.00% Impervious Area

Tc (min)	Length (feet)	Slope (ft/ft)	Velocity (ft/sec)	Capacity (cfs)	Description
5.0					Direct Entry,

Subcatchment 29S: Area to CB#15

Hydrograph

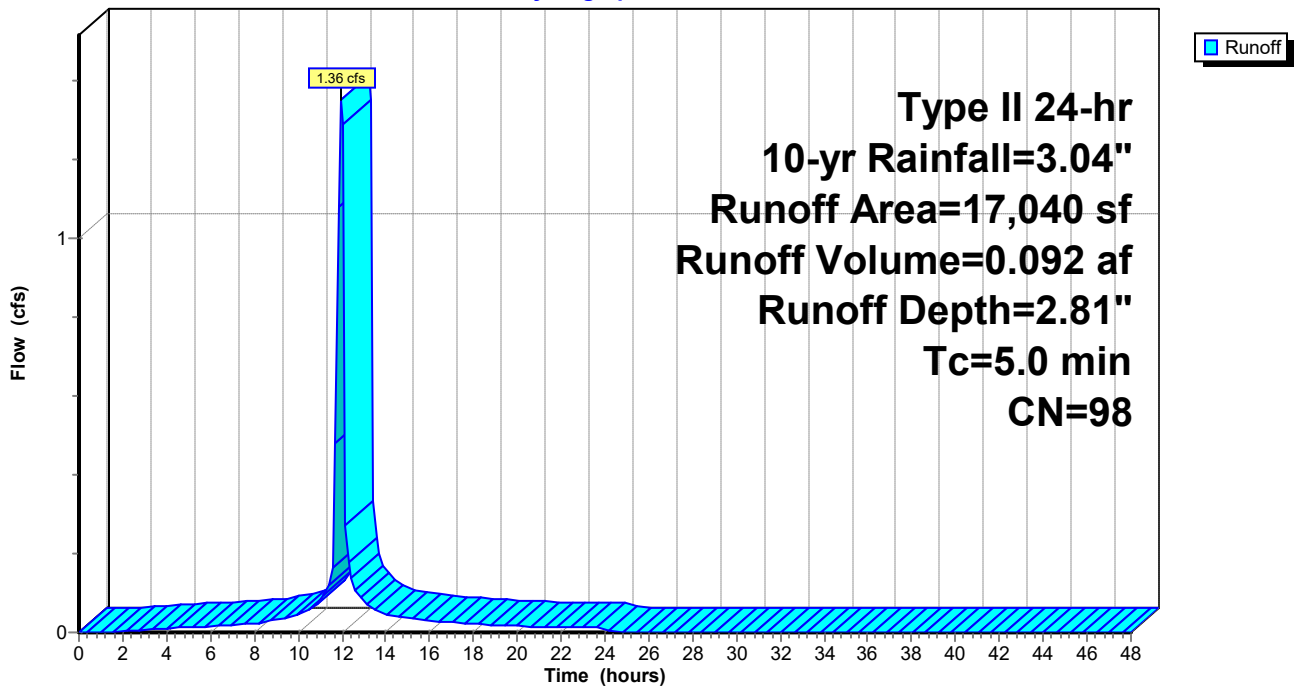

Plug Power - Proposed Conditions 5-15-21

Type II 24-hr 10-yr Rainfall=3.04"

Prepared by {enter your company name here}

Printed 5/20/2021

HydroCAD® 10.10-5a s/n 11585 © 2020 HydroCAD Software Solutions LLC

Page 103

Summary for Subcatchment 30S: Area to CB#18

Runoff = 0.60 cfs @ 12.18 hrs, Volume= 0.052 af, Depth= 1.34"

Runoff by SCS TR-20 method, UH=SCS, Weighted-CN, Time Span= 0.00-48.00 hrs, dt= 0.15 hrs
Type II 24-hr 10-yr Rainfall=3.04"

Area (sf)	CN	Adj	Description
3,025	98		Unconnected pavement, HSG D
17,075	80		>75% Grass cover, Good, HSG D
20,100	83	81	Weighted Average, UI Adjusted
17,075			84.95% Pervious Area
3,025			15.05% Impervious Area
3,025			100.00% Unconnected

Tc (min)	Length (feet)	Slope (ft/ft)	Velocity (ft/sec)	Capacity (cfs)	Description
23.0	100	0.0100	0.07		Sheet Flow, 100' Overland Flow
					Grass: Dense n= 0.240 P2= 2.14"
0.4	40	0.0100	1.50		Shallow Concentrated Flow, 40' Shallow Conc. Flow
					Grassed Waterway Kv= 15.0 fps
23.4	140	Total			

Subcatchment 30S: Area to CB#18

Hydrograph

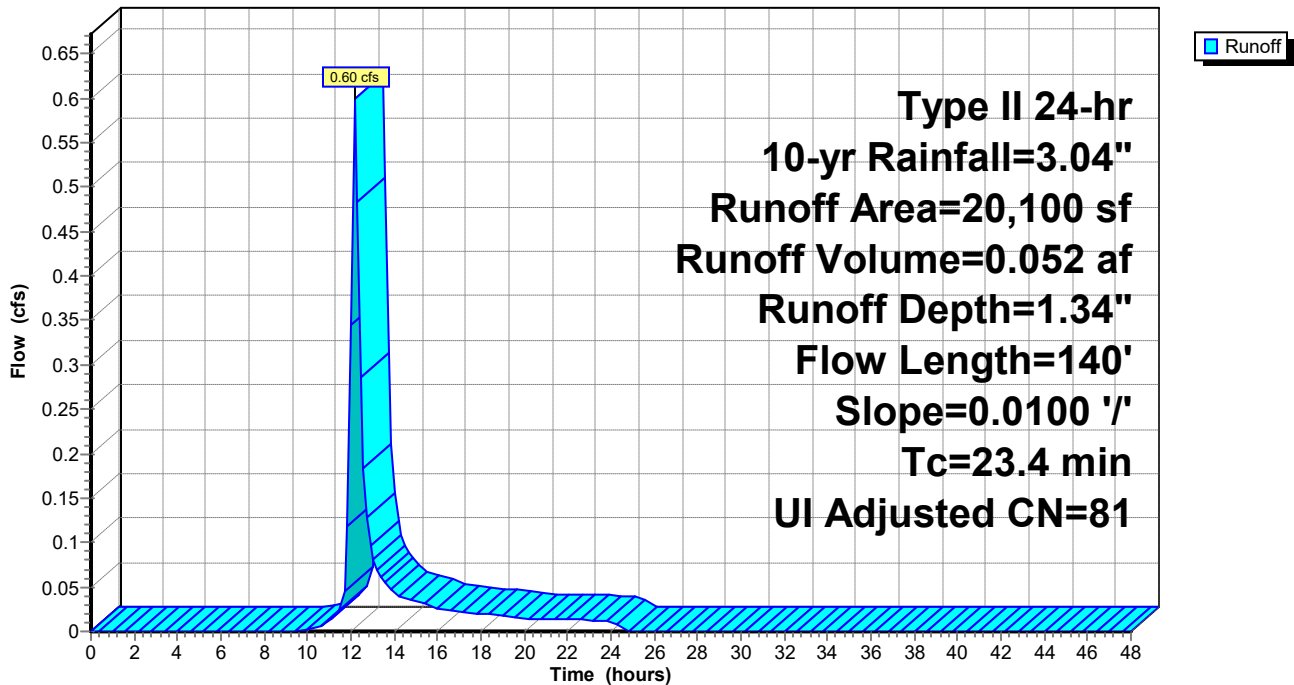

Plug Power - Proposed Conditions 5-15-21

Type II 24-hr 10-yr Rainfall=3.04"

Prepared by {enter your company name here}

Printed 5/20/2021

HydroCAD® 10.10-5a s/n 11585 © 2020 HydroCAD Software Solutions LLC

Page 104

Summary for Subcatchment 32S: Area to CB#7

Runoff = 1.95 cfs @ 12.10 hrs, Volume= 0.152 af, Depth= 2.20"

Runoff by SCS TR-20 method, UH=SCS, Weighted-CN, Time Span= 0.00-48.00 hrs, dt= 0.15 hrs
Type II 24-hr 10-yr Rainfall=3.04"

Area (sf)	CN	Description
25,120	98	Paved parking, HSG D
11,100	80	>75% Grass cover, Good, HSG D
36,220	92	Weighted Average
11,100		30.65% Pervious Area
25,120		69.35% Impervious Area

Tc (min)	Length (feet)	Slope (ft/ft)	Velocity (ft/sec)	Capacity (cfs)	Description
16.3	65	0.0100	0.07		Sheet Flow, 65' Overland Flow
					Grass: Dense n= 0.240 P2= 2.14"
0.6	35	0.0200	0.91		Sheet Flow, 35' Overland Flow
					Smooth surfaces n= 0.011 P2= 2.14"
16.9	100	Total			

Subcatchment 32S: Area to CB#7

Hydrograph

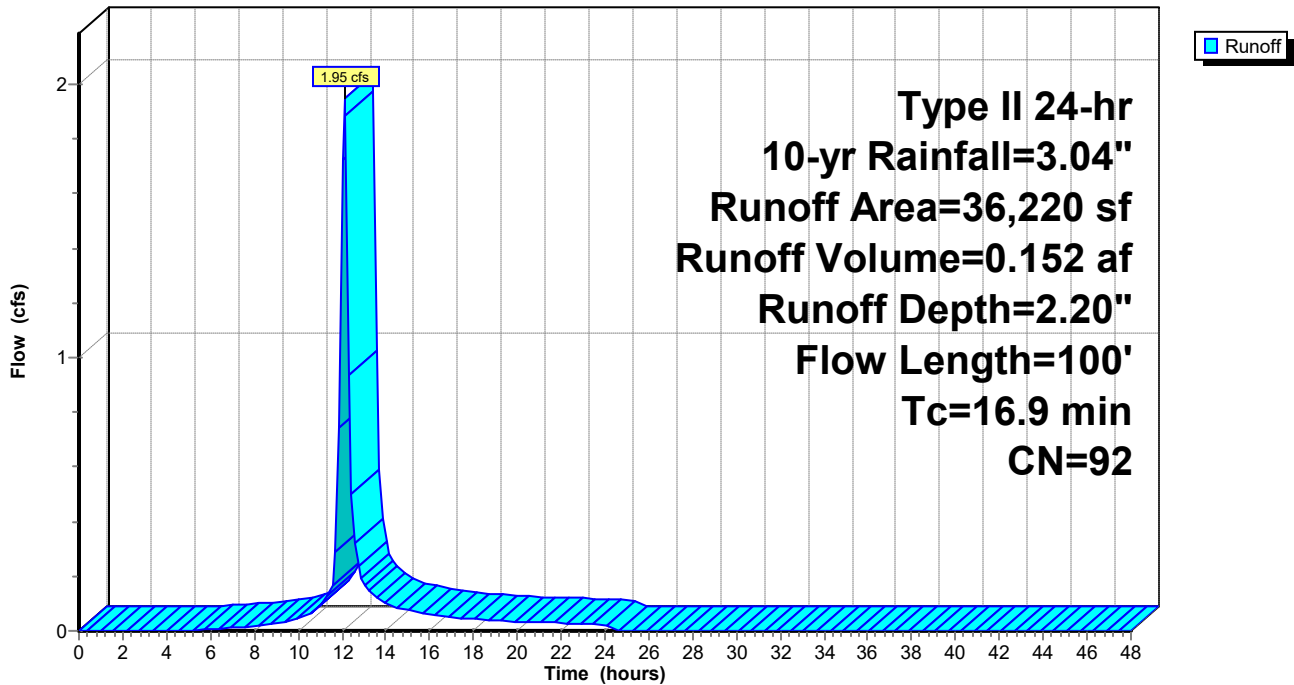

Plug Power - Proposed Conditions 5-15-21

Type II 24-hr 10-yr Rainfall=3.04"

Prepared by {enter your company name here}

Printed 5/20/2021

HydroCAD® 10.10-5a s/n 11585 © 2020 HydroCAD Software Solutions LLC

Page 105

Summary for Subcatchment 36S: Area to CB#9

Runoff = 0.84 cfs @ 12.13 hrs, Volume= 0.066 af, Depth= 1.85"

Runoff by SCS TR-20 method, UH=SCS, Weighted-CN, Time Span= 0.00-48.00 hrs, dt= 0.15 hrs
Type II 24-hr 10-yr Rainfall=3.04"

Area (sf)	CN	Description
5,755	98	Paved parking, HSG D
2,520	98	Unconnected pavement, HSG D
10,200	80	>75% Grass cover, Good, HSG D
18,475	88	Weighted Average
10,200		55.21% Pervious Area
8,275		44.79% Impervious Area
2,520		30.45% Unconnected

Tc (min)	Length (feet)	Slope (ft/ft)	Velocity (ft/sec)	Capacity (cfs)	Description
19.3	80	0.0100	0.07		Sheet Flow, 80' Overland Flow Grass: Dense n= 0.240 P2= 2.14"

Subcatchment 36S: Area to CB#9

Hydrograph

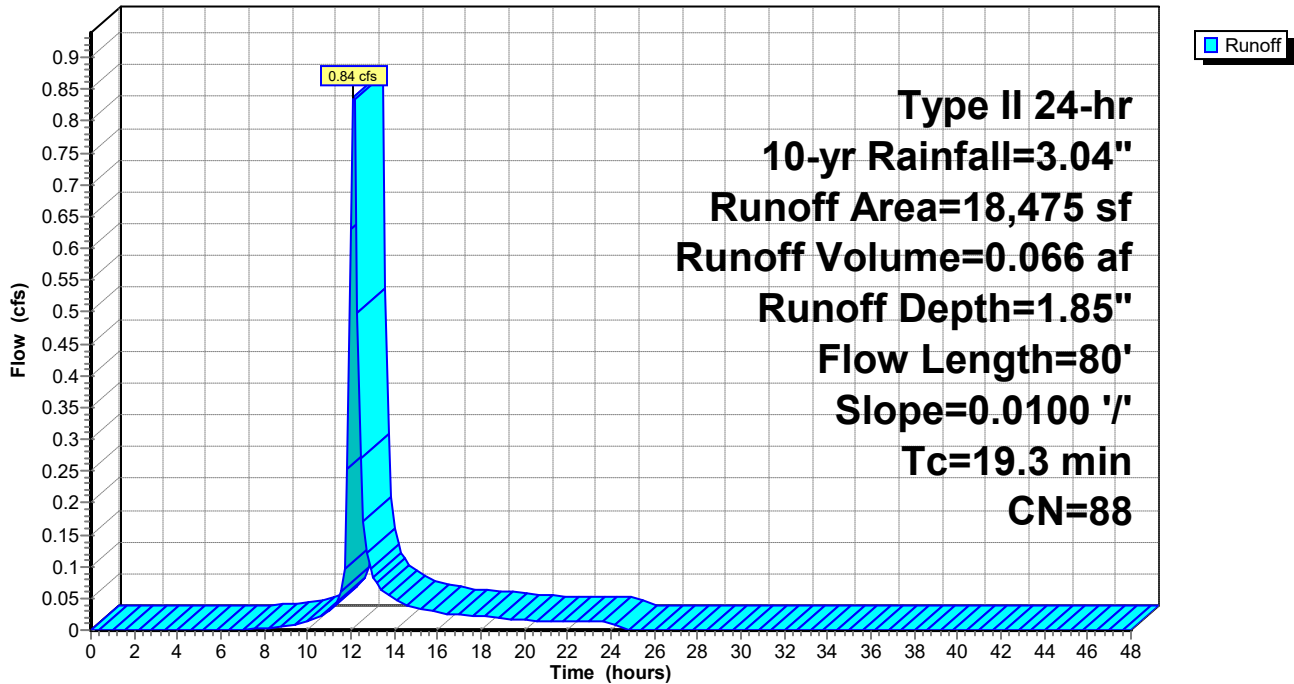

Plug Power - Proposed Conditions 5-15-21

Type II 24-hr 10-yr Rainfall=3.04"

Prepared by {enter your company name here}

Printed 5/20/2021

HydroCAD® 10.10-5a s/n 11585 © 2020 HydroCAD Software Solutions LLC

Page 106

Summary for Subcatchment 38S: Area to CB#10

Runoff = 1.40 cfs @ 12.15 hrs, Volume= 0.112 af, Depth= 1.48"

Runoff by SCS TR-20 method, UH=SCS, Weighted-CN, Time Span= 0.00-48.00 hrs, dt= 0.15 hrs
Type II 24-hr 10-yr Rainfall=3.04"

Area (sf)	CN	Description
8,155	79	Woods, Fair, HSG D
5,920	78	Meadow, non-grazed, HSG D
6,730	98	Paved parking, HSG D
18,845	80	>75% Grass cover, Good, HSG D
39,650	83	Weighted Average
32,920		83.03% Pervious Area
6,730		16.97% Impervious Area

Tc (min)	Length (feet)	Slope (ft/ft)	Velocity (ft/sec)	Capacity (cfs)	Description
20.1	100	0.0140	0.08		Sheet Flow, 100' Overland Flow
					Grass: Dense n= 0.240 P2= 2.14"
0.5	50	0.0140	1.77		Shallow Concentrated Flow, 50' Shallow Conc. Flow
					Grassed Waterway Kv= 15.0 fps
20.6	150	Total			

Subcatchment 38S: Area to CB#10

Hydrograph

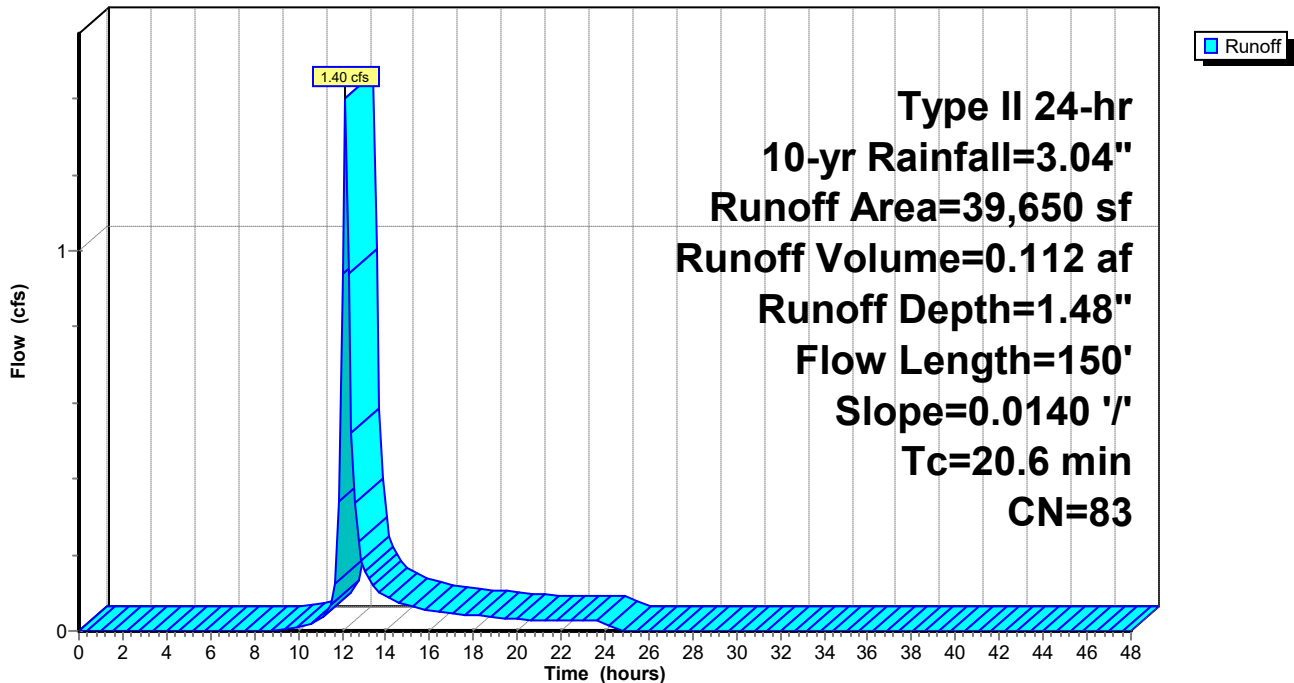

Plug Power - Proposed Conditions 5-15-21

Type II 24-hr 10-yr Rainfall=3.04"

Prepared by {enter your company name here}

Printed 5/20/2021

HydroCAD® 10.10-5a s/n 11585 © 2020 HydroCAD Software Solutions LLC

Page 107

Summary for Subcatchment 40S: Area to CB#11

Runoff = 1.86 cfs @ 12.15 hrs, Volume= 0.169 af, Depth= 2.81"

Runoff by SCS TR-20 method, UH=SCS, Weighted-CN, Time Span= 0.00-48.00 hrs, dt= 0.15 hrs
Type II 24-hr 10-yr Rainfall=3.04"

Area (sf)	CN	Description
4,960	98	Paved parking, HSG D
26,535	98	Paved parking, HSG D
31,495	98	Weighted Average
31,495		100.00% Impervious Area

Tc (min)	Length (feet)	Slope (ft/ft)	Velocity (ft/sec)	Capacity (cfs)	Description
21.4	100	0.0120	0.08		Sheet Flow, 100' Overland Flow Grass: Dense n= 0.240 P2= 2.14"
0.7	70	0.0120	1.64		Shallow Concentrated Flow, 70' Shallow Conc. Flow Grassed Waterway Kv= 15.0 fps
22.1	170	Total			

Subcatchment 40S: Area to CB#11

Hydrograph

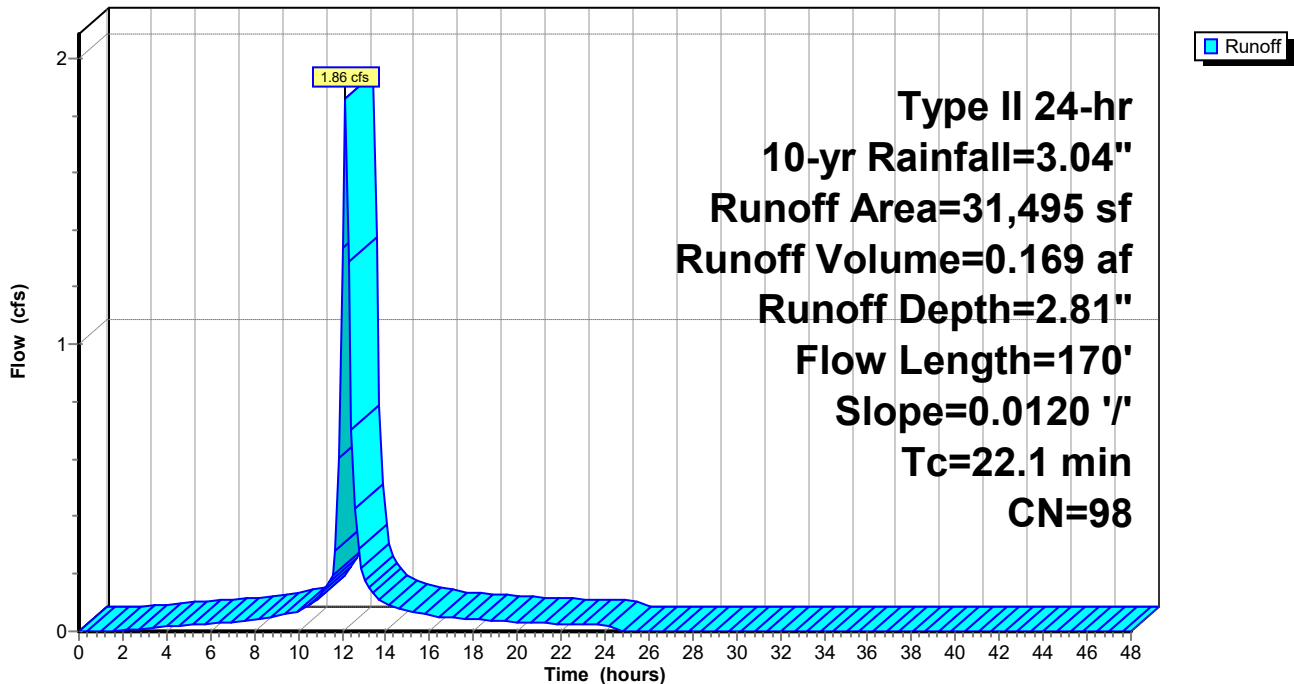

Plug Power - Proposed Conditions 5-15-21

Type II 24-hr 10-yr Rainfall=3.04"

Prepared by {enter your company name here}

Printed 5/20/2021

HydroCAD® 10.10-5a s/n 11585 © 2020 HydroCAD Software Solutions LLC

Page 108

Summary for Subcatchment 42S: Western Area Overland to Gravel Storage

Runoff = 8.69 cfs @ 11.98 hrs, Volume= 0.495 af, Depth= 1.85"

Runoff by SCS TR-20 method, UH=SCS, Weighted-CN, Time Span= 0.00-48.00 hrs, dt= 0.15 hrs
Type II 24-hr 10-yr Rainfall=3.04"

Area (sf)	CN	Description
* 53,390	80	Gravel Storage Area, Good, HSG D
31,080	98	Paved parking, HSG D
2,460	98	Unconnected pavement, HSG D
26,630	80	>75% Grass cover, Good, HSG D
26,105	98	Roofs, HSG D
139,665	88	Weighted Average
80,020		57.29% Pervious Area
59,645		42.71% Impervious Area
2,460		4.12% Unconnected

Tc (min)	Length (feet)	Slope (ft/ft)	Velocity (ft/sec)	Capacity (cfs)	Description
5.8	25	0.0200	0.07		Sheet Flow, 25' Overland Flow Grass: Dense n= 0.240 P2= 2.14"
0.5	25	0.0200	0.85		Sheet Flow, 25' Overland Flow Smooth surfaces n= 0.011 P2= 2.14"
6.3	50	Total			

Subcatchment 42S: Western Area Overland to Gravel Storage

Hydrograph

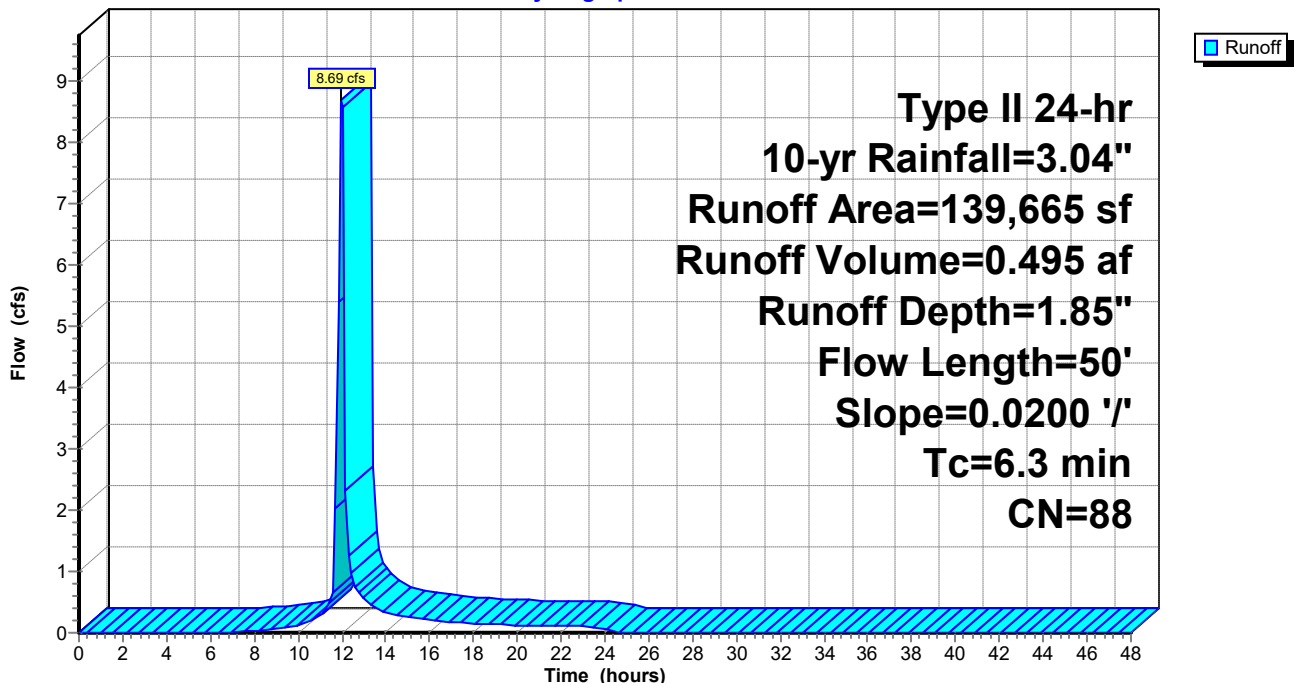

Plug Power - Proposed Conditions 5-15-21

Type II 24-hr 10-yr Rainfall=3.04"

Prepared by {enter your company name here}

Printed 5/20/2021

HydroCAD® 10.10-5a s/n 11585 © 2020 HydroCAD Software Solutions LLC

Page 109

Summary for Subcatchment 43S: North Half of Phase 2 Building

Runoff = 2.90 cfs @ 11.95 hrs, Volume= 0.196 af, Depth= 2.81"

Runoff by SCS TR-20 method, UH=SCS, Weighted-CN, Time Span= 0.00-48.00 hrs, dt= 0.15 hrs
Type II 24-hr 10-yr Rainfall=3.04"

Area (sf)	CN	Description
36,505	98	Roofs, HSG D
36,505		100.00% Impervious Area

Tc (min)	Length (feet)	Slope (ft/ft)	Velocity (ft/sec)	Capacity (cfs)	Description
5.0					Direct Entry,

Subcatchment 43S: North Half of Phase 2 Building

Hydrograph

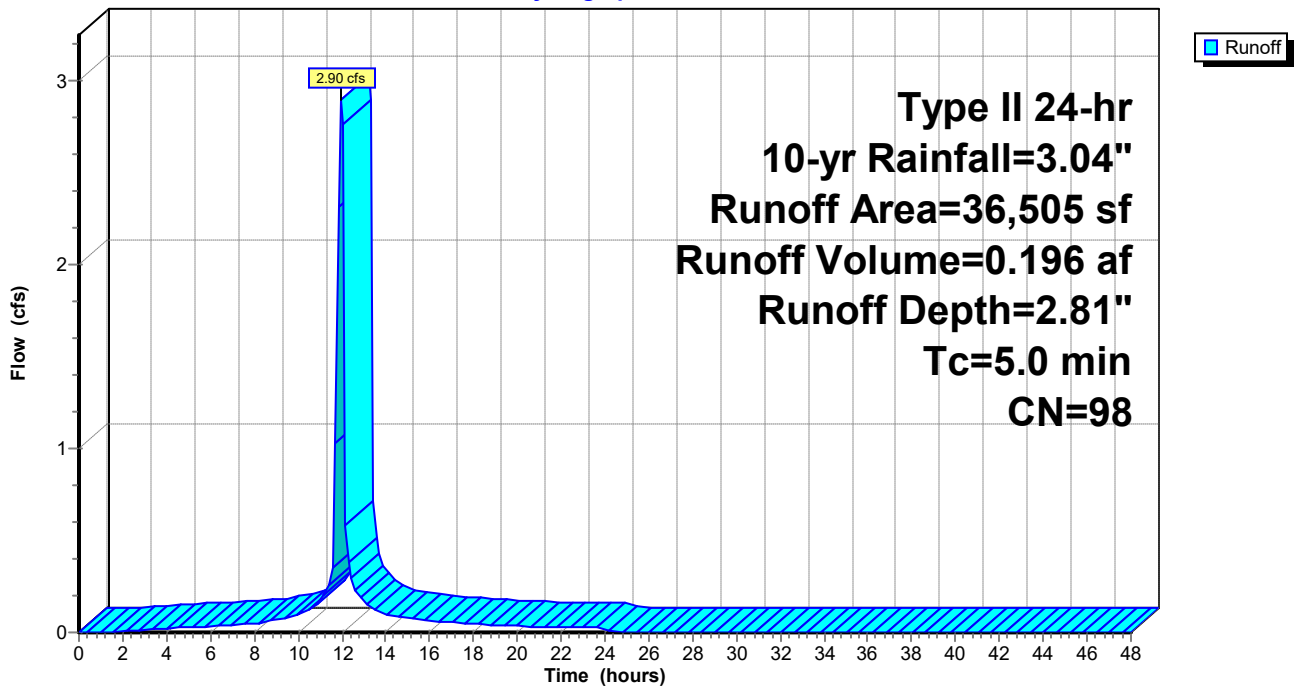

Plug Power - Proposed Conditions 5-15-21

Type II 24-hr 10-yr Rainfall=3.04"

Prepared by {enter your company name here}

Printed 5/20/2021

HydroCAD® 10.10-5a s/n 11585 © 2020 HydroCAD Software Solutions LLC

Page 110

Summary for Subcatchment 45S: South Half of Phase 2 Building

Runoff = 2.57 cfs @ 11.95 hrs, Volume= 0.173 af, Depth= 2.81"

Runoff by SCS TR-20 method, UH=SCS, Weighted-CN, Time Span= 0.00-48.00 hrs, dt= 0.15 hrs
Type II 24-hr 10-yr Rainfall=3.04"

Area (sf)	CN	Description
32,290	98	Roofs, HSG D
32,290		100.00% Impervious Area

Tc (min)	Length (feet)	Slope (ft/ft)	Velocity (ft/sec)	Capacity (cfs)	Description
5.0					Direct Entry,

Subcatchment 45S: South Half of Phase 2 Building

Hydrograph

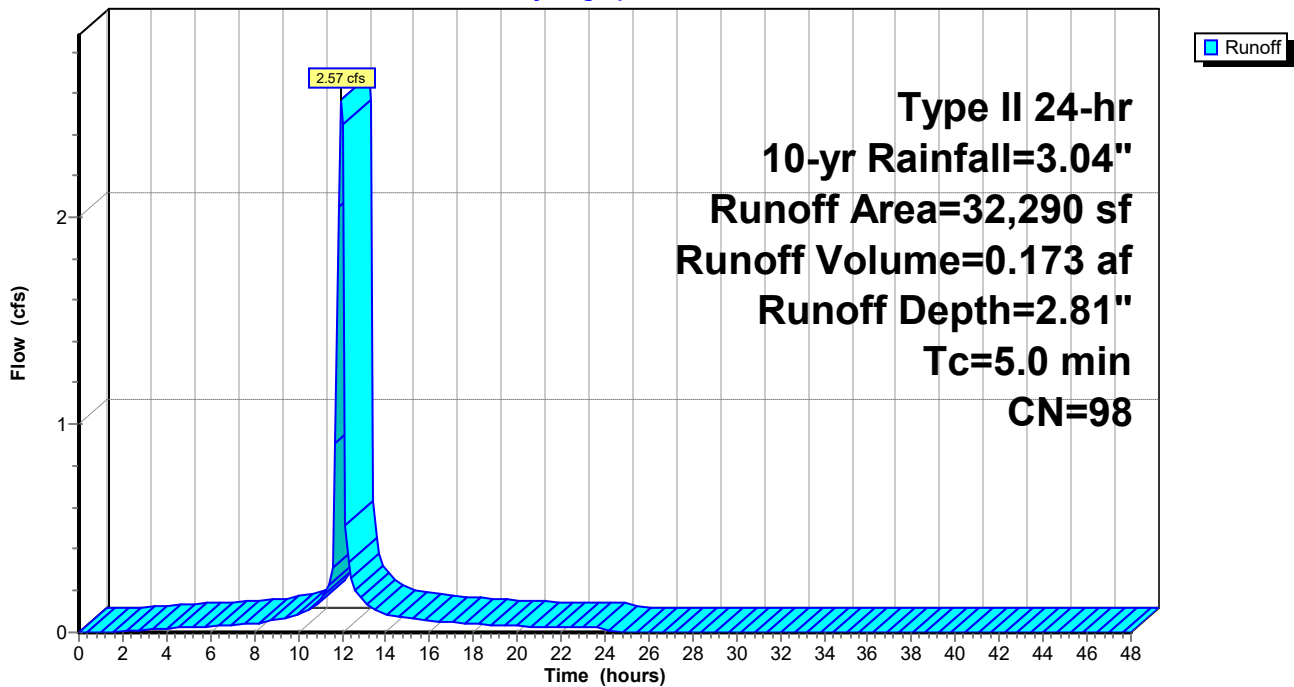

Plug Power - Proposed Conditions 5-15-21

Type II 24-hr 10-yr Rainfall=3.04"

Prepared by {enter your company name here}

Printed 5/20/2021

HydroCAD® 10.10-5a s/n 11585 © 2020 HydroCAD Software Solutions LLC

Page 111

Summary for Subcatchment 48S: Area to YD#1

Runoff = 1.35 cfs @ 12.17 hrs, Volume= 0.115 af, Depth= 1.77"

Runoff by SCS TR-20 method, UH=SCS, Weighted-CN, Time Span= 0.00-48.00 hrs, dt= 0.15 hrs
Type II 24-hr 10-yr Rainfall=3.04"

Area (sf)	CN	Description
2,610	98	Roofs, HSG D
21,165	80	>75% Grass cover, Good, HSG D
10,255	98	Paved parking, HSG D
34,030	87	Weighted Average
21,165		62.20% Pervious Area
12,865		37.80% Impervious Area

Tc (min)	Length (feet)	Slope (ft/ft)	Velocity (ft/sec)	Capacity (cfs)	Description
23.0	100	0.0100	0.07		Sheet Flow, 100' Overland Flow
					Grass: Dense n= 0.240 P2= 2.14"
0.6	50	0.0100	1.50		Shallow Concentrated Flow, 50' Shallow Conc. Flow
					Grassed Waterway Kv= 15.0 fps
23.6	150	Total			

Subcatchment 48S: Area to YD#1

Hydrograph

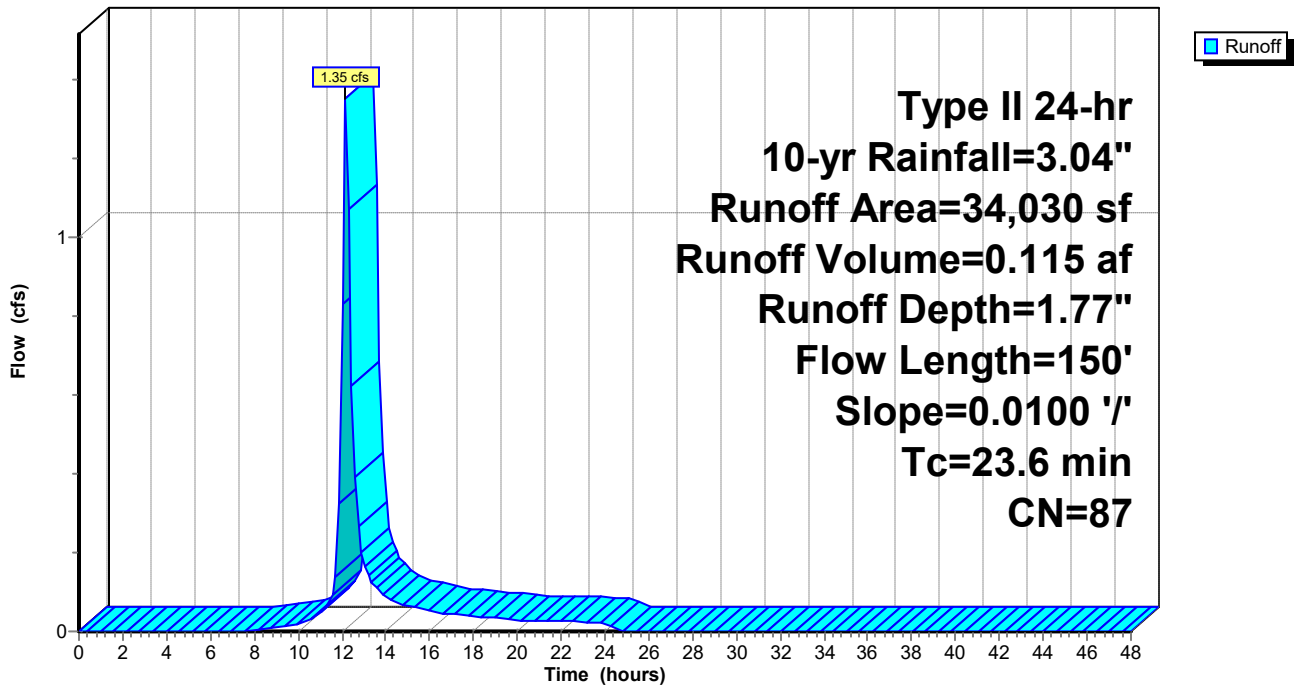

Plug Power - Proposed Conditions 5-15-21

Type II 24-hr 10-yr Rainfall=3.04"

Prepared by {enter your company name here}

Printed 5/20/2021

HydroCAD® 10.10-5a s/n 11585 © 2020 HydroCAD Software Solutions LLC

Page 112

Summary for Subcatchment 49S: Area to YD#3

Runoff = 2.84 cfs @ 12.19 hrs, Volume= 0.254 af, Depth= 1.62"

Runoff by SCS TR-20 method, UH=SCS, Weighted-CN, Time Span= 0.00-48.00 hrs, dt= 0.15 hrs
Type II 24-hr 10-yr Rainfall=3.04"

Area (sf)	CN	Description
20,040	98	Paved parking, HSG D
57,195	80	>75% Grass cover, Good, HSG D
4,600	98	Roofs, HSG D
81,835	85	Weighted Average
57,195		69.89% Pervious Area
24,640		30.11% Impervious Area

Tc (min)	Length (feet)	Slope (ft/ft)	Velocity (ft/sec)	Capacity (cfs)	Description
23.0	100	0.0100	0.07		Sheet Flow, 100' Overland Flow Grass: Dense n= 0.240 P2= 2.14"
0.3	60	0.0200	2.87		Shallow Concentrated Flow, 60' Shallow Conc. Flow Paved Kv= 20.3 fps
2.0	180	0.0100	1.50		Shallow Concentrated Flow, 180' Shallow Conc. Flow Grassed Waterway Kv= 15.0 fps
25.3	340	Total			

Subcatchment 49S: Area to YD#3

Hydrograph

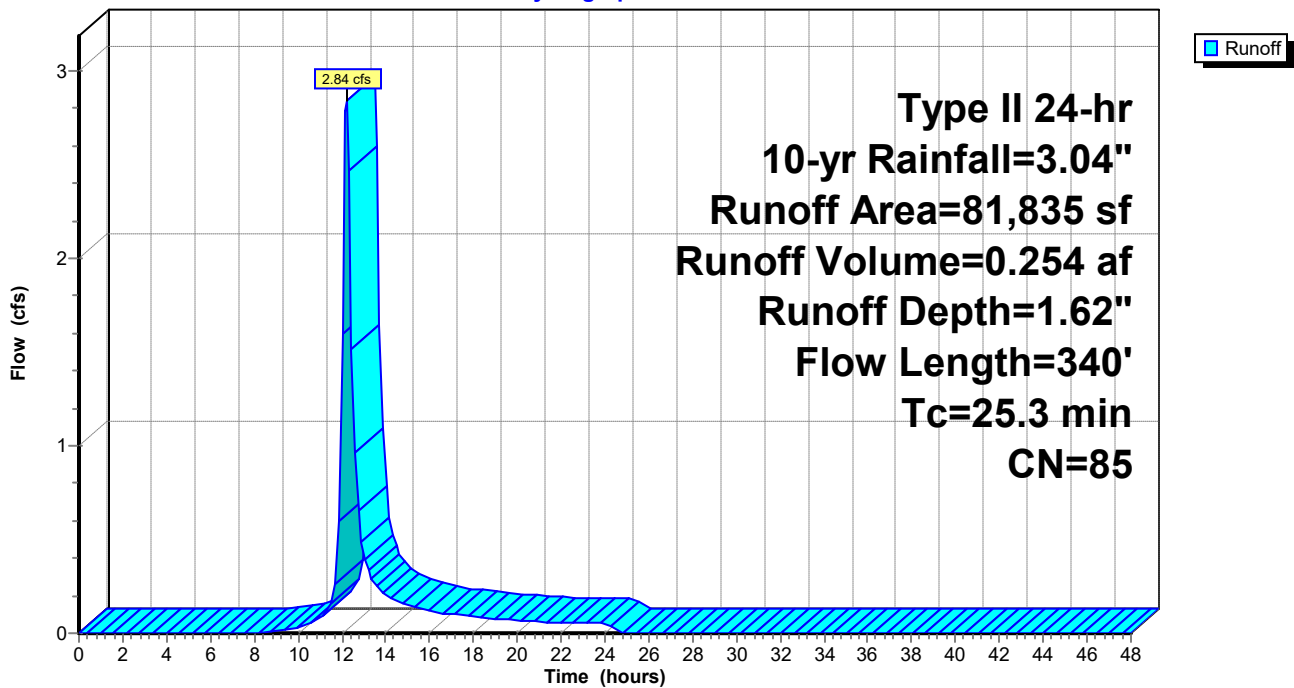

Plug Power - Proposed Conditions 5-15-21

Type II 24-hr 10-yr Rainfall=3.04"

Prepared by {enter your company name here}

Printed 5/20/2021

HydroCAD® 10.10-5a s/n 11585 © 2020 HydroCAD Software Solutions LLC

Page 113

Summary for Subcatchment 52S: Area Overland to Bio-Retention Area

Runoff = 3.09 cfs @ 11.98 hrs, Volume= 0.175 af, Depth= 1.28"

Runoff by SCS TR-20 method, UH=SCS, Weighted-CN, Time Span= 0.00-48.00 hrs, dt= 0.15 hrs
Type II 24-hr 10-yr Rainfall=3.04"

Area (sf)	CN	Description
71,325	80	>75% Grass cover, Good, HSG D
71,325		100.00% Pervious Area

Tc (min)	Length (feet)	Slope (ft/ft)	Velocity (ft/sec)	Capacity (cfs)	Description
3.6	10	0.0100	0.05		Sheet Flow, 10' Overland Flow Grass: Dense n= 0.240 P2= 2.14"
1.8	20	0.2500	0.19		Sheet Flow, 20' Overland Flow Grass: Dense n= 0.240 P2= 2.14"
5.4	30	Total			

Subcatchment 52S: Area Overland to Bio-Retention Area

Hydrograph

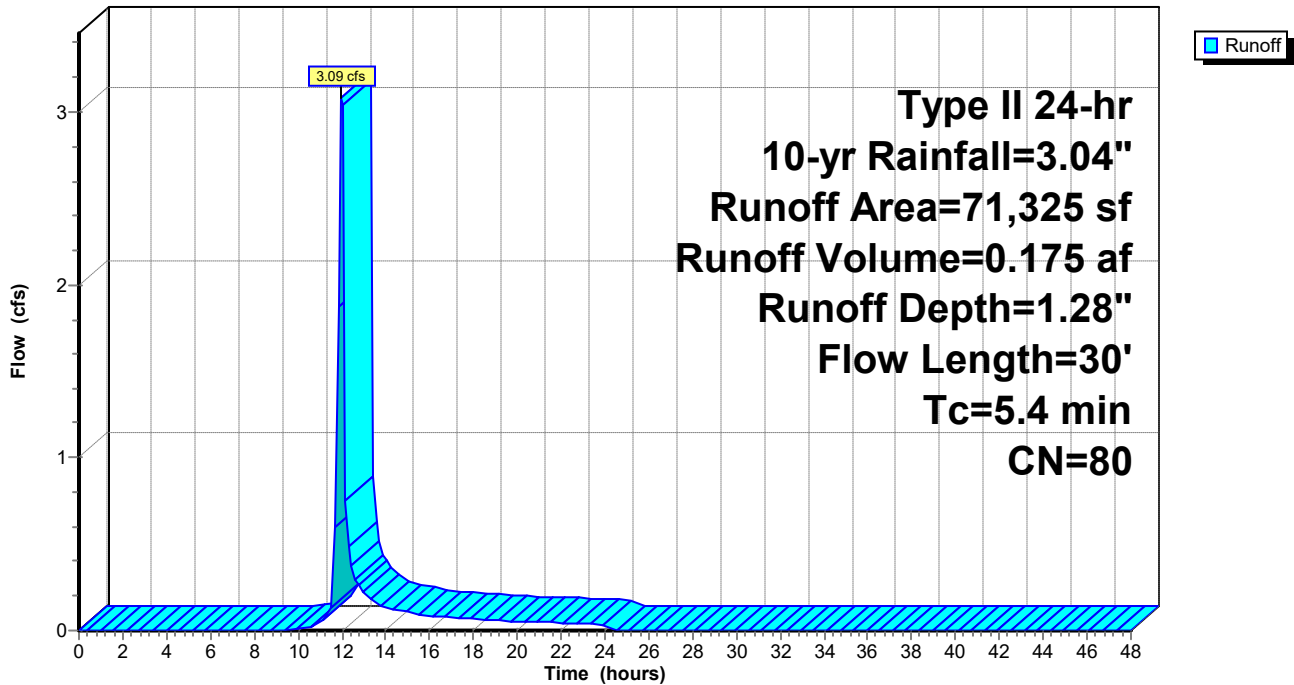

Plug Power - Proposed Conditions 5-15-21

Type II 24-hr 10-yr Rainfall=3.04"

Prepared by {enter your company name here}

Printed 5/20/2021

HydroCAD® 10.10-5a s/n 11585 © 2020 HydroCAD Software Solutions LLC

Page 114

Summary for Subcatchment 53S: Area Overland to Western Swale to Bio-Retention Area

Runoff = 0.25 cfs @ 11.97 hrs, Volume= 0.015 af, Depth= 1.28"

Runoff by SCS TR-20 method, UH=SCS, Weighted-CN, Time Span= 0.00-48.00 hrs, dt= 0.15 hrs
Type II 24-hr 10-yr Rainfall=3.04"

Area (sf)	CN	Description
5,925	80	>75% Grass cover, Good, HSG D
5,925		100.00% Pervious Area

Tc (min)	Length (feet)	Slope (ft/ft)	Velocity (ft/sec)	Capacity (cfs)	Description
5.0					Direct Entry,

Subcatchment 53S: Area Overland to Western Swale to Bio-Retention Area

Hydrograph

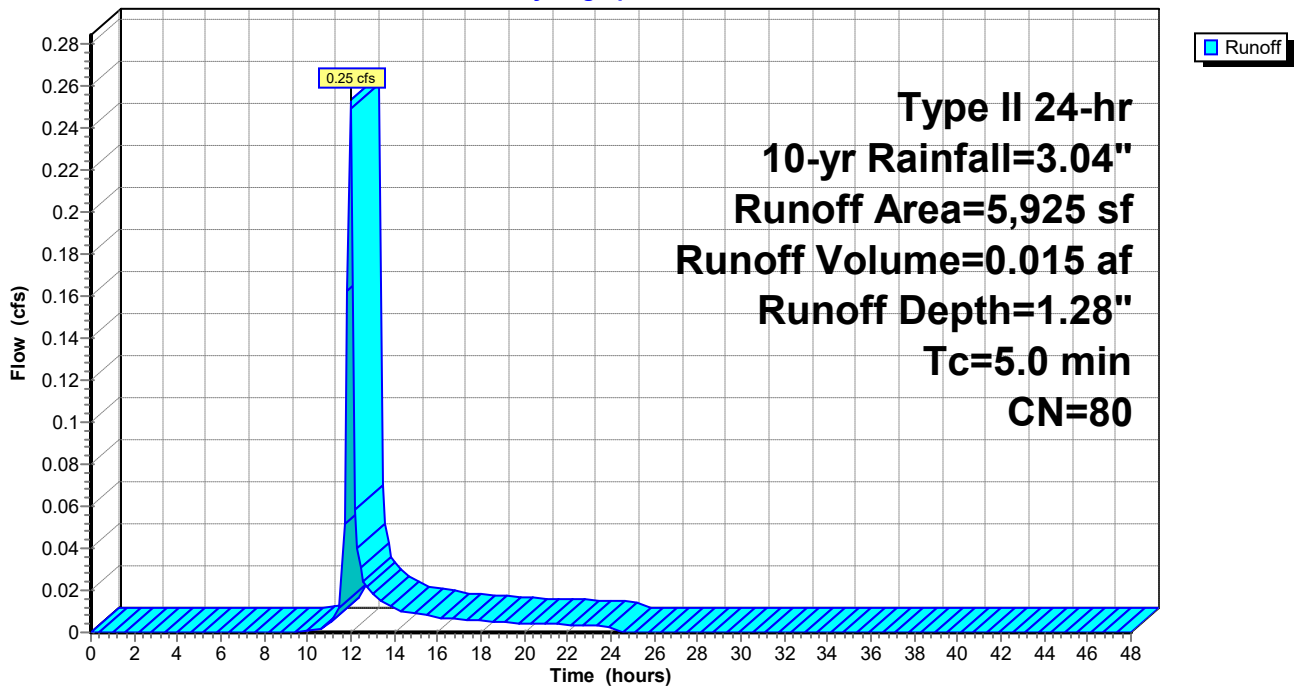

Plug Power - Proposed Conditions 5-15-21

Type II 24-hr 10-yr Rainfall=3.04"

Prepared by {enter your company name here}

Printed 5/20/2021

HydroCAD® 10.10-5a s/n 11585 © 2020 HydroCAD Software Solutions LLC

Page 115

Summary for Subcatchment 54S: Area Overland to Northern Swale to Bio-Retention Area

Runoff = 0.26 cfs @ 11.97 hrs, Volume= 0.015 af, Depth= 1.28"

Runoff by SCS TR-20 method, UH=SCS, Weighted-CN, Time Span= 0.00-48.00 hrs, dt= 0.15 hrs
Type II 24-hr 10-yr Rainfall=3.04"

Area (sf)	CN	Description
6,040	80	>75% Grass cover, Good, HSG D
6,040		100.00% Pervious Area

Tc (min)	Length (feet)	Slope (ft/ft)	Velocity (ft/sec)	Capacity (cfs)	Description
5.0					Direct Entry,

Subcatchment 54S: Area Overland to Northern Swale to Bio-Retention Area

Hydrograph

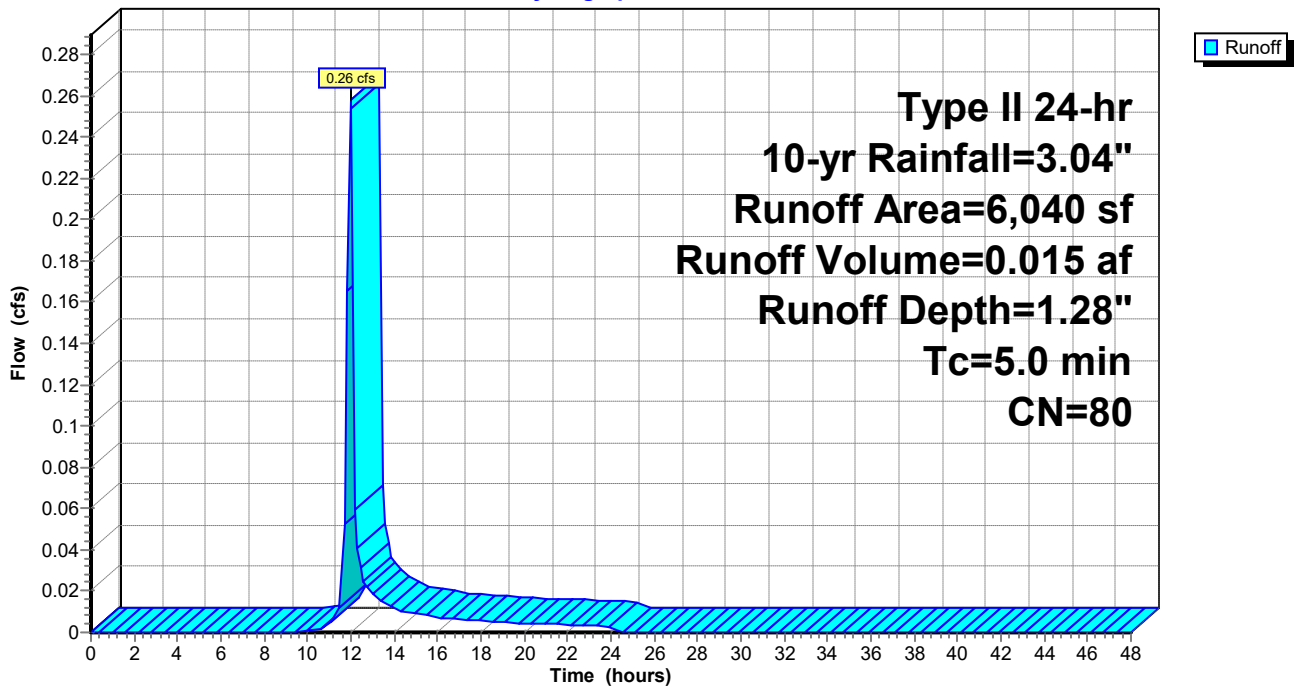

Plug Power - Proposed Conditions 5-15-21

Type II 24-hr 10-yr Rainfall=3.04"

Prepared by {enter your company name here}

Printed 5/20/2021

HydroCAD® 10.10-5a s/n 11585 © 2020 HydroCAD Software Solutions LLC

Page 116

Summary for Subcatchment 55S: Area Overland to Swales to Dry Pond

Runoff = 0.57 cfs @ 11.99 hrs, Volume= 0.032 af, Depth= 1.28"

Runoff by SCS TR-20 method, UH=SCS, Weighted-CN, Time Span= 0.00-48.00 hrs, dt= 0.15 hrs
Type II 24-hr 10-yr Rainfall=3.04"

Area (sf)	CN	Description
13,210	80	>75% Grass cover, Good, HSG D
13,210		100.00% Pervious Area

Tc (min)	Length (feet)	Slope (ft/ft)	Velocity (ft/sec)	Capacity (cfs)	Description
7.6	25	0.0100	0.05		Sheet Flow, 25' Overland Flow Grass: Dense n= 0.240 P2= 2.14"

Subcatchment 55S: Area Overland to Swales to Dry Pond

Hydrograph

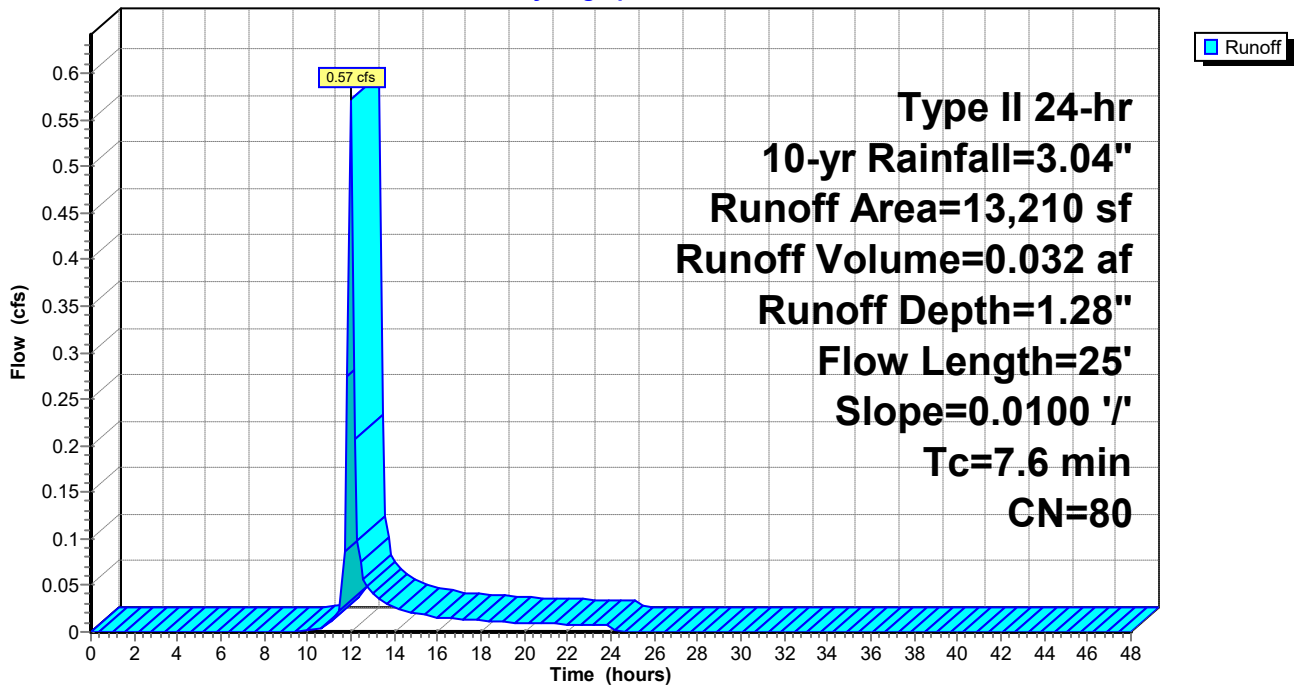

Summary for Subcatchment 56S: Area Overland to Dry Pond

Runoff = 0.82 cfs @ 11.97 hrs, Volume= 0.047 af, Depth= 1.28"

Runoff by SCS TR-20 method, UH=SCS, Weighted-CN, Time Span= 0.00-48.00 hrs, dt= 0.15 hrs
 Type II 24-hr 10-yr Rainfall=3.04"

Area (sf)	CN	Description
19,245	80	>75% Grass cover, Good, HSG D
19,245		100.00% Pervious Area

Tc (min)	Length (feet)	Slope (ft/ft)	Velocity (ft/sec)	Capacity (cfs)	Description
5.0					Direct Entry,

Subcatchment 56S: Area Overland to Dry Pond

Hydrograph

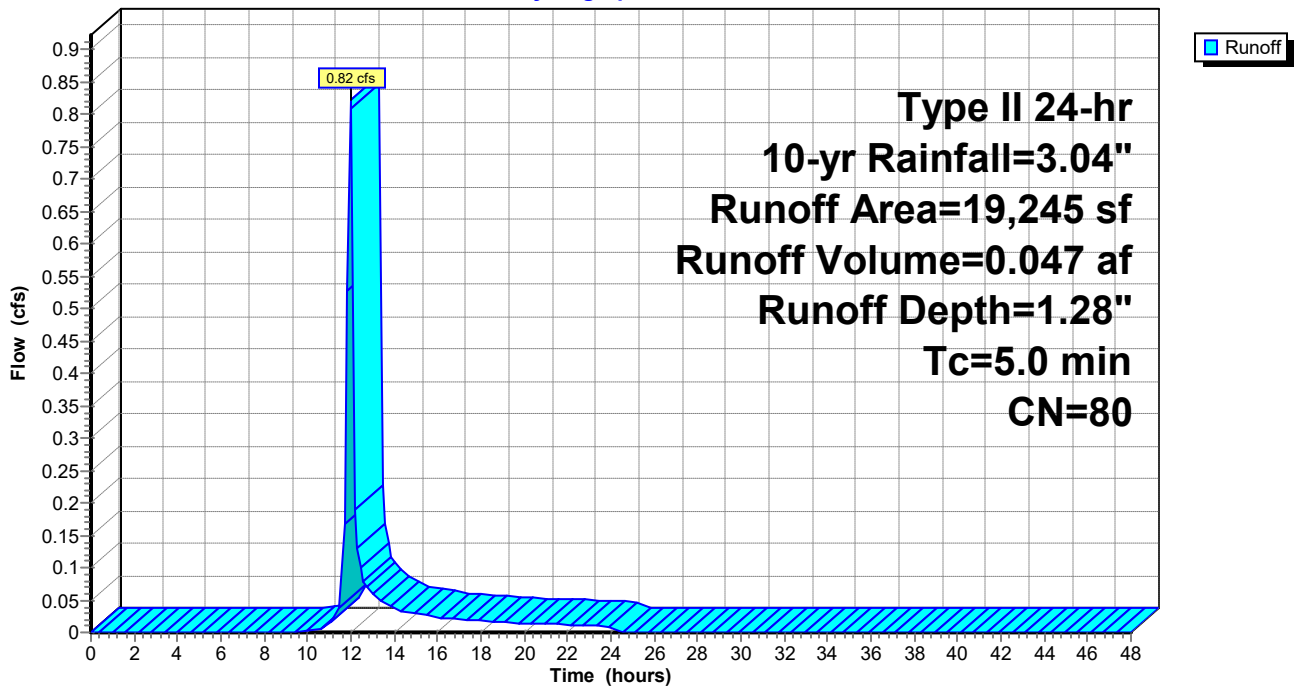

Plug Power - Proposed Conditions 5-15-21

Type II 24-hr 10-yr Rainfall=3.04"

Prepared by {enter your company name here}

Printed 5/20/2021

HydroCAD® 10.10-5a s/n 11585 © 2020 HydroCAD Software Solutions LLC

Page 118

Summary for Subcatchment 57S: Area Overland to North Prop. Line and Wetland Ditch (Central)

Runoff = 0.77 cfs @ 12.02 hrs, Volume= 0.050 af, Depth= 1.10"

Runoff by SCS TR-20 method, UH=SCS, Weighted-CN, Time Span= 0.00-48.00 hrs, dt= 0.15 hrs
Type II 24-hr 10-yr Rainfall=3.04"

Area (sf)	CN	Description
23,585	77	Brush, Fair, HSG D
23,585		100.00% Pervious Area

Tc (min)	Length (feet)	Slope (ft/ft)	Velocity (ft/sec)	Capacity (cfs)	Description
10.6	70	0.0100	0.11		Sheet Flow, 70' Overland Flow Range n= 0.130 P2= 2.14"
0.2	30	0.1000	2.21		Shallow Concentrated Flow, 30' Shallow Conc. Flow Short Grass Pasture Kv= 7.0 fps
10.8	100	Total			

Subcatchment 57S: Area Overland to North Prop. Line and Wetland Ditch (Central)

Hydrograph

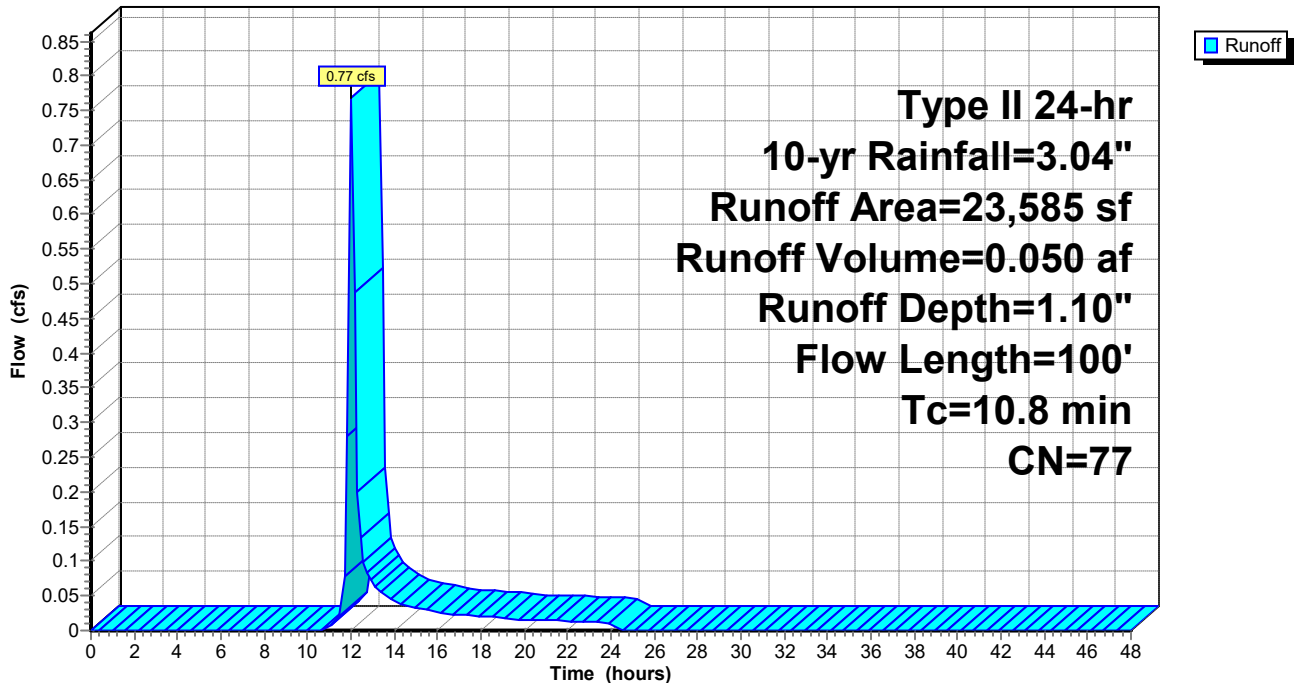

Plug Power - Proposed Conditions 5-15-21

Type II 24-hr 10-yr Rainfall=3.04"

Prepared by {enter your company name here}

Printed 5/20/2021

HydroCAD® 10.10-5a s/n 11585 © 2020 HydroCAD Software Solutions LLC

Page 119

Summary for Subcatchment 58S: Area Overland to North Prop. Line and Wetland Ditch (West)

Runoff = 0.46 cfs @ 12.09 hrs, Volume= 0.036 af, Depth= 1.10"

Runoff by SCS TR-20 method, UH=SCS, Weighted-CN, Time Span= 0.00-48.00 hrs, dt= 0.15 hrs
Type II 24-hr 10-yr Rainfall=3.04"

Area (sf)	CN	Description
17,005	77	Brush, Fair, HSG D
17,005		100.00% Pervious Area

Tc (min)	Length (feet)	Slope (ft/ft)	Velocity (ft/sec)	Capacity (cfs)	Description
14.1	100	0.0100	0.12		Sheet Flow, 100' Overland Flow Range n= 0.130 P2= 2.14"
0.8	70	0.0400	1.40		Shallow Concentrated Flow, 70' Shallow Conc. Flow Short Grass Pasture Kv= 7.0 fps
14.9	170	Total			

Subcatchment 58S: Area Overland to North Prop. Line and Wetland Ditch (West)

Hydrograph

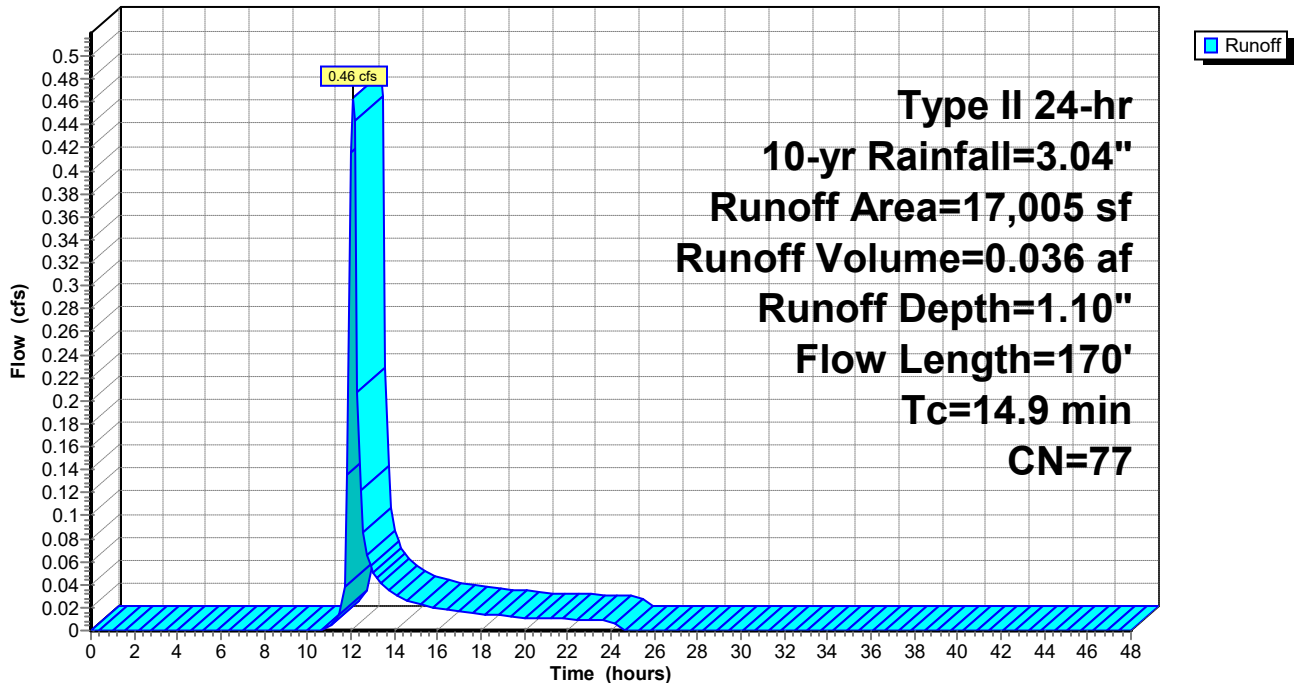

Plug Power - Proposed Conditions 5-15-21

Type II 24-hr 10-yr Rainfall=3.04"

Prepared by {enter your company name here}

Printed 5/20/2021

HydroCAD® 10.10-5a s/n 11585 © 2020 HydroCAD Software Solutions LLC

Page 120

Summary for Reach 7R: Crosby Road Ditch

Inflow Area = 0.230 ac, 0.00% Impervious, Inflow Depth = 1.22" for 10-yr event
Inflow = 0.27 cfs @ 12.18 hrs, Volume= 0.023 af
Outflow = 0.23 cfs @ 12.30 hrs, Volume= 0.023 af, Atten= 13%, Lag= 7.1 min

Routing by Dyn-Stor-Ind method, Time Span= 0.00-48.00 hrs, dt= 0.15 hrs
Max. Velocity= 0.93 fps, Min. Travel Time= 8.1 min
Avg. Velocity = 0.37 fps, Avg. Travel Time= 20.0 min

Peak Storage= 114 cf @ 12.30 hrs
Average Depth at Peak Storage= 0.10' , Surface Width= 2.83'
Bank-Full Depth= 2.00' Flow Area= 20.0 sf, Capacity= 98.41 cfs

2.00' x 2.00' deep channel, n= 0.030
Side Slope Z-value= 4.0 '/' Top Width= 18.00'
Length= 450.0' Slope= 0.0089 '/'
Inlet Invert= 673.00', Outlet Invert= 669.00'

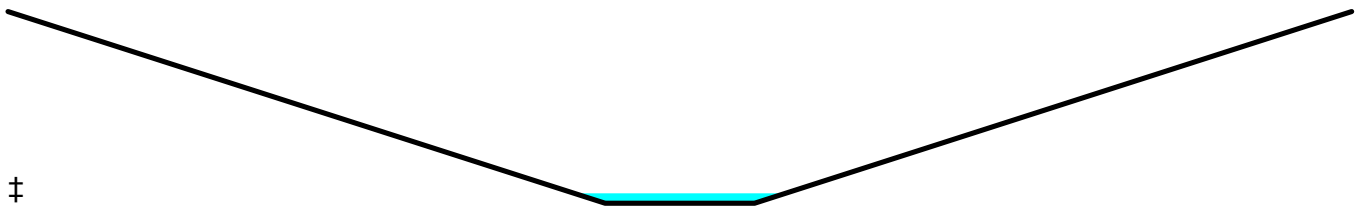

Reach 7R: Crosby Road Ditch

Hydrograph

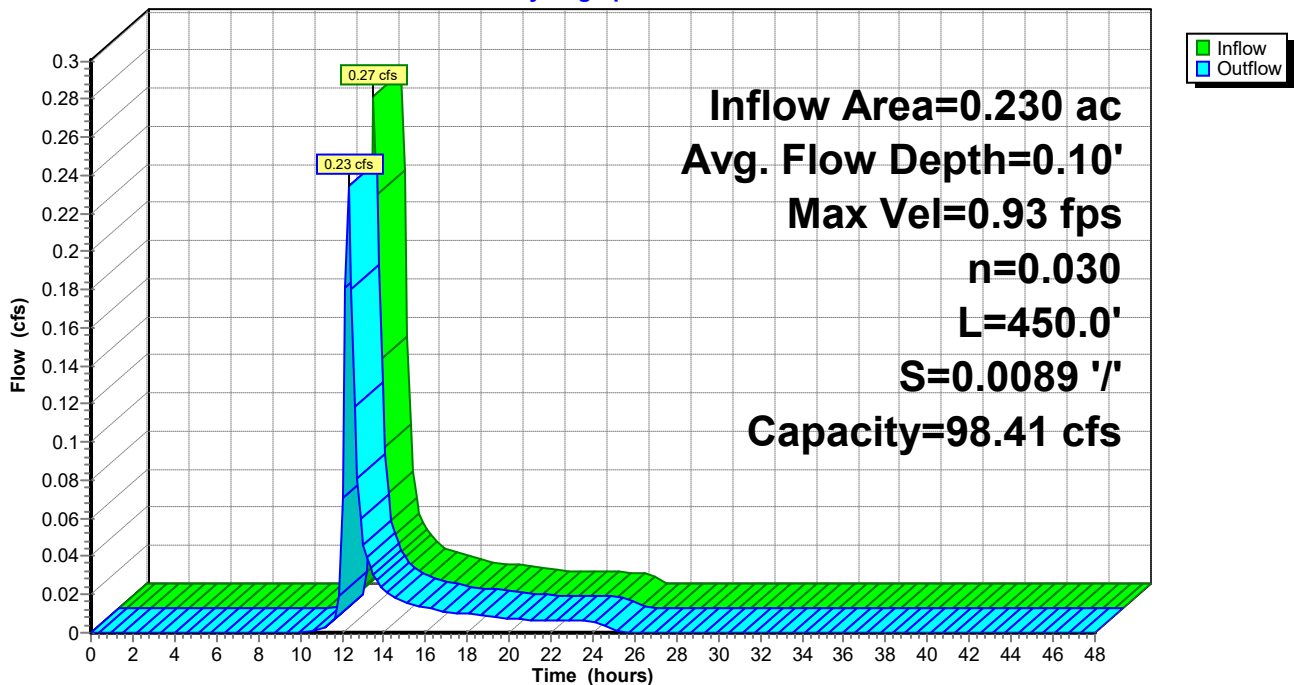

Plug Power - Proposed Conditions 5-15-21

Type II 24-hr 10-yr Rainfall=3.04"

Prepared by {enter your company name here}

Printed 5/20/2021

HydroCAD® 10.10-5a s/n 11585 © 2020 HydroCAD Software Solutions LLC

Page 121

Summary for Reach 9R: North Property Line Ditch (East)

Inflow Area = 1.403 ac, 0.00% Impervious, Inflow Depth = 1.12" for 10-yr event
Inflow = 1.68 cfs @ 12.04 hrs, Volume= 0.131 af
Outflow = 1.39 cfs @ 12.17 hrs, Volume= 0.131 af, Atten= 18%, Lag= 7.5 min

Routing by Dyn-Stor-Ind method, Time Span= 0.00-48.00 hrs, dt= 0.15 hrs
Max. Velocity= 1.40 fps, Min. Travel Time= 8.0 min
Avg. Velocity = 0.57 fps, Avg. Travel Time= 19.6 min

Peak Storage= 666 cf @ 12.17 hrs
Average Depth at Peak Storage= 0.23' , Surface Width= 6.61'
Bank-Full Depth= 3.00' Flow Area= 96.0 sf, Capacity= 634.40 cfs

2.00' x 3.00' deep channel, n= 0.030 Earth, grassed & winding
Side Slope Z-value= 10.0 ' / ' Top Width= 62.00'
Length= 670.0' Slope= 0.0100 ' / '
Inlet Invert= 669.00', Outlet Invert= 662.30'

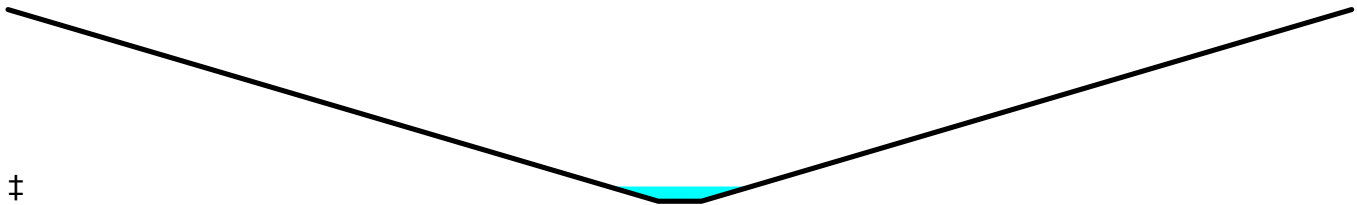

Reach 9R: North Property Line Ditch (East)

Hydrograph

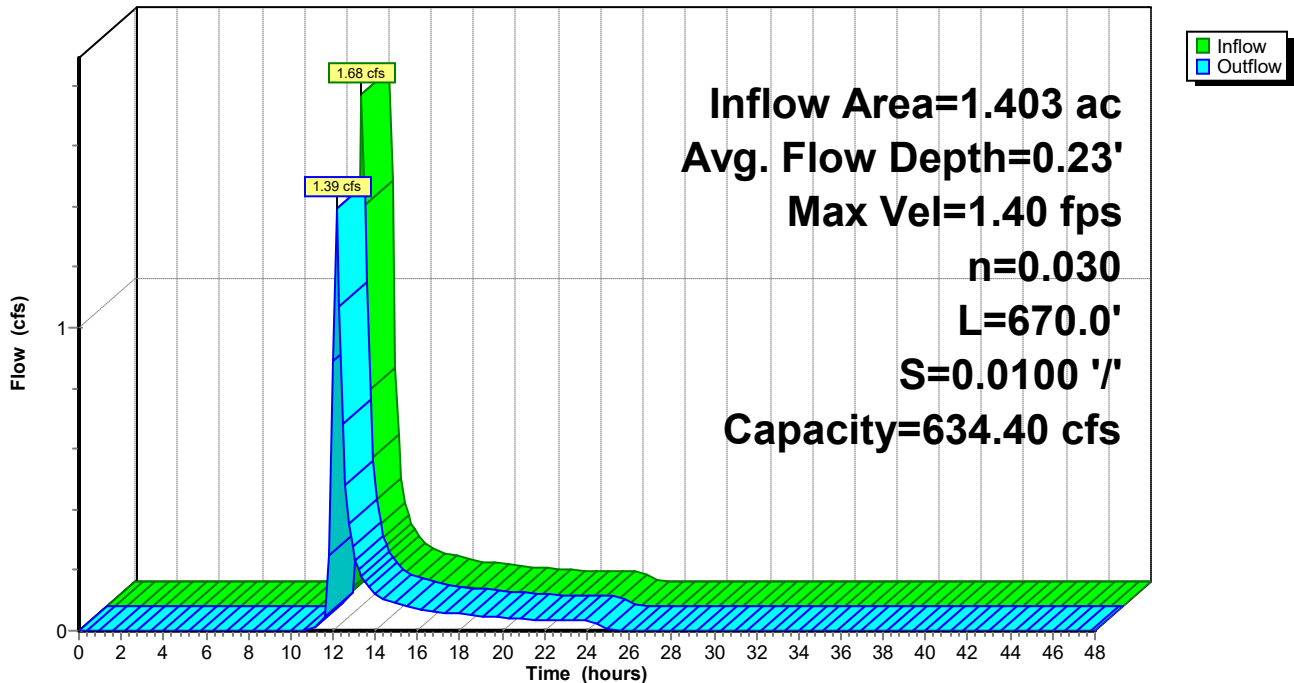

Plug Power - Proposed Conditions 5-15-21

Type II 24-hr 10-yr Rainfall=3.04"

Prepared by {enter your company name here}

Printed 5/20/2021

HydroCAD® 10.10-5a s/n 11585 © 2020 HydroCAD Software Solutions LLC

Page 122

Summary for Reach 23R: North Swale to Bio-Retention Area

Inflow Area = 0.139 ac, 0.00% Impervious, Inflow Depth =129.96" for 10-yr event
Inflow = 9.94 cfs @ 12.11 hrs, Volume= 1.502 af
Outflow = 9.55 cfs @ 12.22 hrs, Volume= 1.502 af, Atten= 4%, Lag= 6.7 min

Routing by Dyn-Stor-Ind method, Time Span= 0.00-48.00 hrs, dt= 0.15 hrs
Max. Velocity= 0.39 fps, Min. Travel Time= 7.7 min
Avg. Velocity = 0.11 fps, Avg. Travel Time= 26.4 min

Peak Storage= 4,395 cf @ 12.22 hrs
Average Depth at Peak Storage= 2.02' , Surface Width= 20.18'
Bank-Full Depth= 3.00' Flow Area= 48.0 sf, Capacity= 23.67 cfs

4.00' x 3.00' deep channel, n= 0.300
Side Slope Z-value= 4.0 ' / ' Top Width= 28.00'
Length= 180.0' Slope= 0.0050 ' / '
Inlet Invert= 663.90', Outlet Invert= 663.00'



Reach 23R: North Swale to Bio-Retention Area

Hydrograph

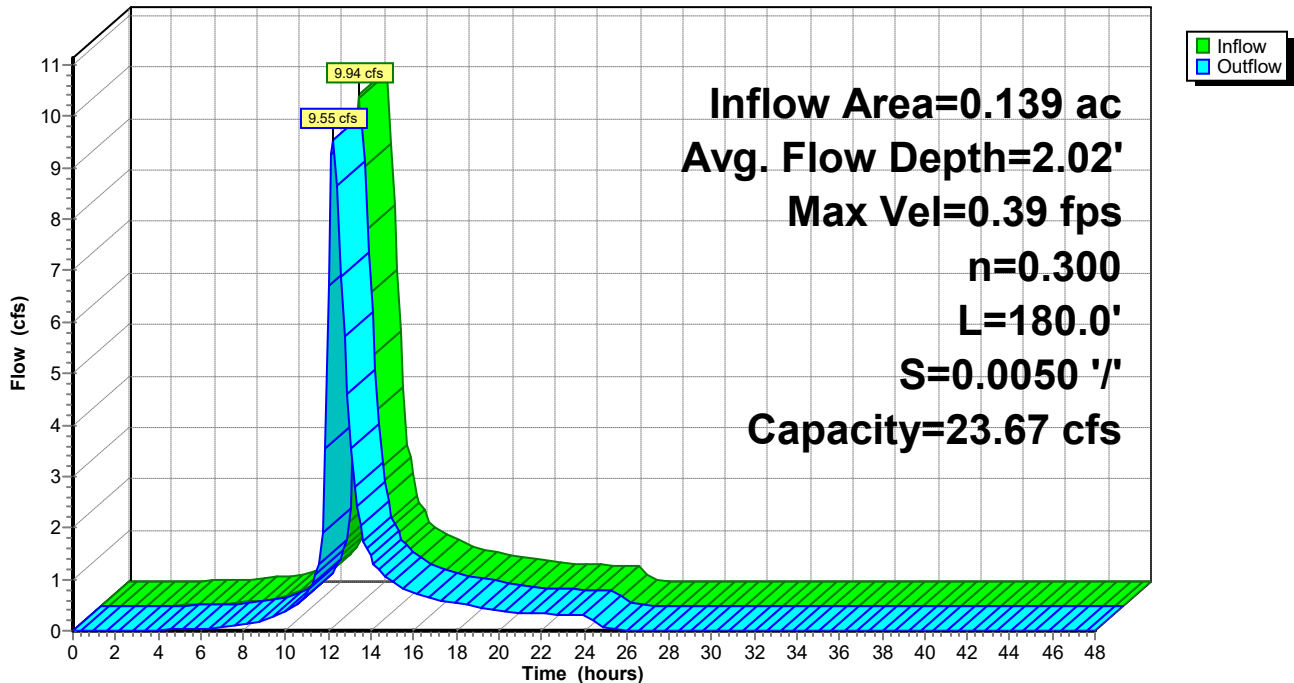

Plug Power - Proposed Conditions 5-15-21

Type II 24-hr 10-yr Rainfall=3.04"

Prepared by {enter your company name here}

Printed 5/20/2021

HydroCAD® 10.10-5a s/n 11585 © 2020 HydroCAD Software Solutions LLC

Page 123

Summary for Reach 25R: North Property Line Ditch (Central0)

Inflow Area = 2.689 ac, 0.00% Impervious, Inflow Depth = 2.34" for 10-yr event
Inflow = 3.00 cfs @ 12.34 hrs, Volume= 0.524 af
Outflow = 2.92 cfs @ 12.46 hrs, Volume= 0.524 af, Atten= 3%, Lag= 7.1 min

Routing by Dyn-Stor-Ind method, Time Span= 0.00-48.00 hrs, dt= 0.15 hrs
Max. Velocity= 1.21 fps, Min. Travel Time= 6.9 min
Avg. Velocity = 0.45 fps, Avg. Travel Time= 18.4 min

Peak Storage= 1,206 cf @ 12.46 hrs
Average Depth at Peak Storage= 0.40' , Surface Width= 10.02'
Bank-Full Depth= 3.00' Flow Area= 96.0 sf, Capacity= 401.23 cfs

2.00' x 3.00' deep channel, n= 0.030 Earth, grassed & winding
Side Slope Z-value= 10.0 ' / ' Top Width= 62.00'
Length= 500.0' Slope= 0.0040 ' / '
Inlet Invert= 662.30', Outlet Invert= 660.30'

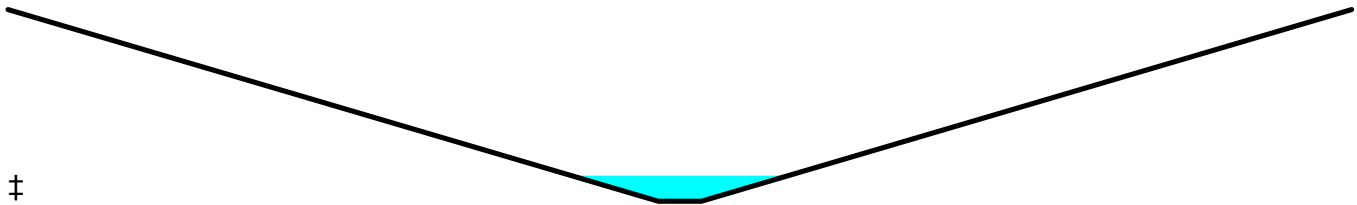

Reach 25R: North Property Line Ditch (Central0)

Hydrograph

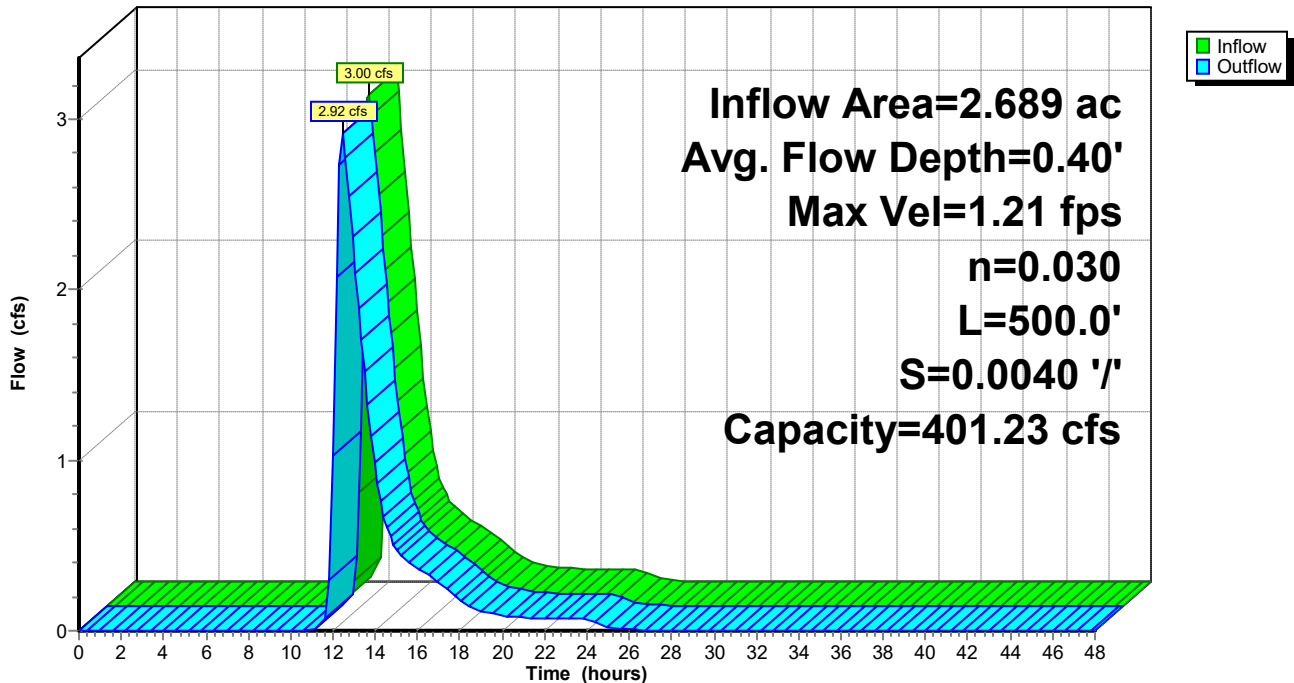

Plug Power - Proposed Conditions 5-15-21

Prepared by {enter your company name here}

HydroCAD® 10.10-5a s/n 11585 © 2020 HydroCAD Software Solutions LLC

Type II 24-hr 10-yr Rainfall=3.04"

Printed 5/20/2021

Page 124

Summary for Reach 26R: North Property Line Ditch (West)

Inflow Area = 27.347 ac, 45.74% Impervious, Inflow Depth = 1.88" for 10-yr event
Inflow = 12.94 cfs @ 12.86 hrs, Volume= 4.286 af
Outflow = 13.22 cfs @ 12.96 hrs, Volume= 4.286 af, Atten= 0%, Lag= 6.5 min

Routing by Dyn-Stor-Ind method, Time Span= 0.00-48.00 hrs, dt= 0.15 hrs
Max. Velocity= 1.45 fps, Min. Travel Time= 5.7 min
Avg. Velocity = 0.66 fps, Avg. Travel Time= 12.6 min

Peak Storage= 4,514 cf @ 12.97 hrs
Average Depth at Peak Storage= 0.86' , Surface Width= 19.13'
Bank-Full Depth= 3.00' Flow Area= 96.0 sf, Capacity= 310.79 cfs

2.00' x 3.00' deep channel, n= 0.030 Earth, grassed & winding
Side Slope Z-value= 10.0 ' / ' Top Width= 62.00'
Length= 500.0' Slope= 0.0024 ' / '
Inlet Invert= 660.30', Outlet Invert= 659.10'

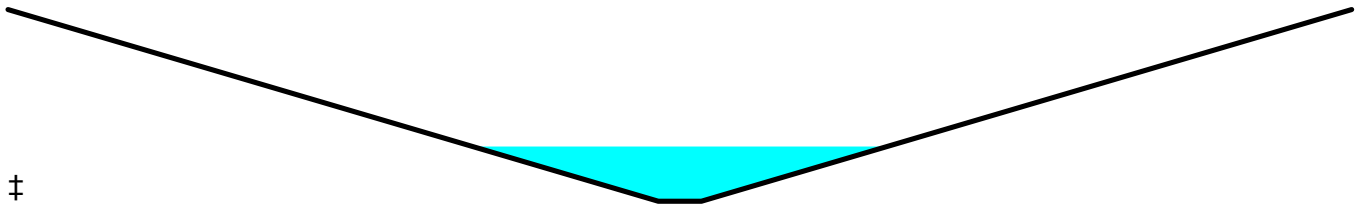

Reach 26R: North Property Line Ditch (West)

Hydrograph

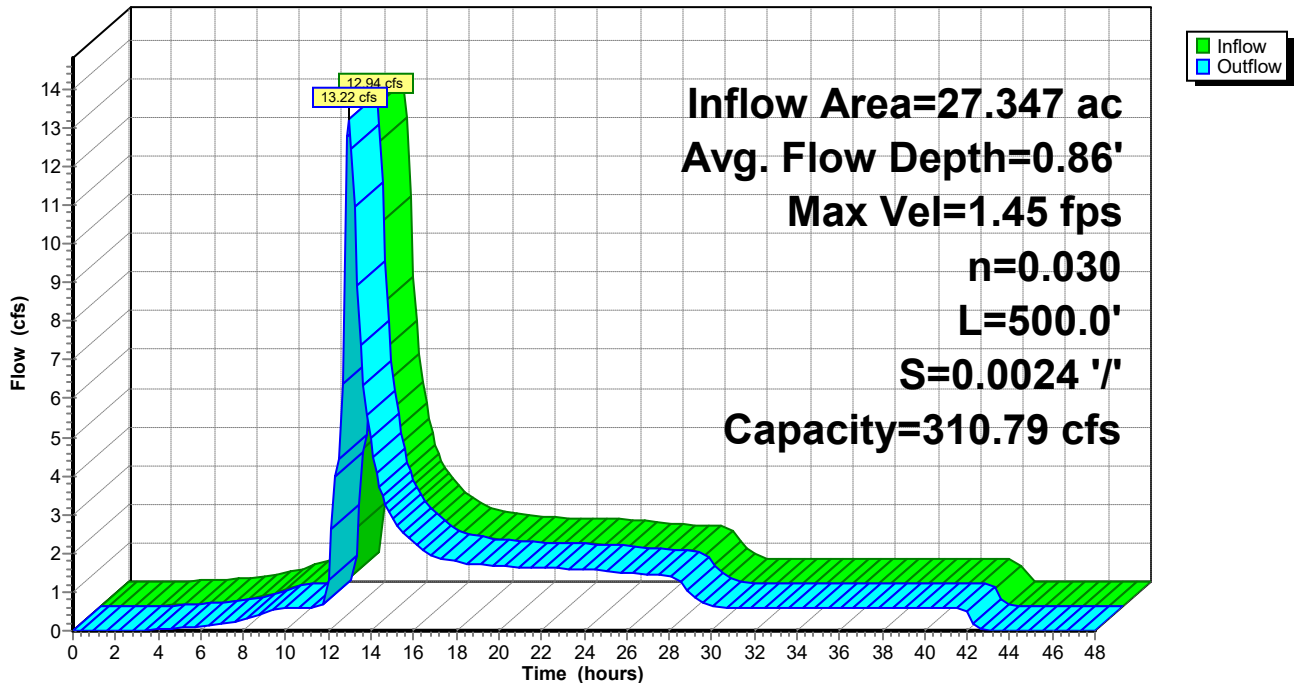

Plug Power - Proposed Conditions 5-15-21

Type II 24-hr 10-yr Rainfall=3.04"

Prepared by {enter your company name here}

Printed 5/20/2021

HydroCAD® 10.10-5a s/n 11585 © 2020 HydroCAD Software Solutions LLC

Page 125

Summary for Reach 27R: Swale to Dry Pond

Inflow Area = 0.303 ac, 0.00% Impervious, Inflow Depth = 11.74" for 10-yr event
Inflow = 9.03 cfs @ 12.20 hrs, Volume= 0.297 af
Outflow = 8.59 cfs @ 12.23 hrs, Volume= 0.297 af, Atten= 5%, Lag= 2.1 min

Routing by Dyn-Stor-Ind method, Time Span= 0.00-48.00 hrs, dt= 0.15 hrs
Max. Velocity= 1.85 fps, Min. Travel Time= 1.2 min
Avg. Velocity = 0.32 fps, Avg. Travel Time= 6.7 min

Peak Storage= 596 cf @ 12.23 hrs
Average Depth at Peak Storage= 0.61' , Surface Width= 11.26'
Bank-Full Depth= 2.00' Flow Area= 32.0 sf, Capacity= 118.87 cfs

A factor of 2.00 has been applied to the storage and discharge capacity
2.00' x 2.00' deep channel, n= 0.030
Side Slope Z-value= 3.0 '/' Top Width= 14.00'
Length= 130.0' Slope= 0.0050 '/'
Inlet Invert= 665.85', Outlet Invert= 665.20'



Reach 27R: Swale to Dry Pond

Hydrograph

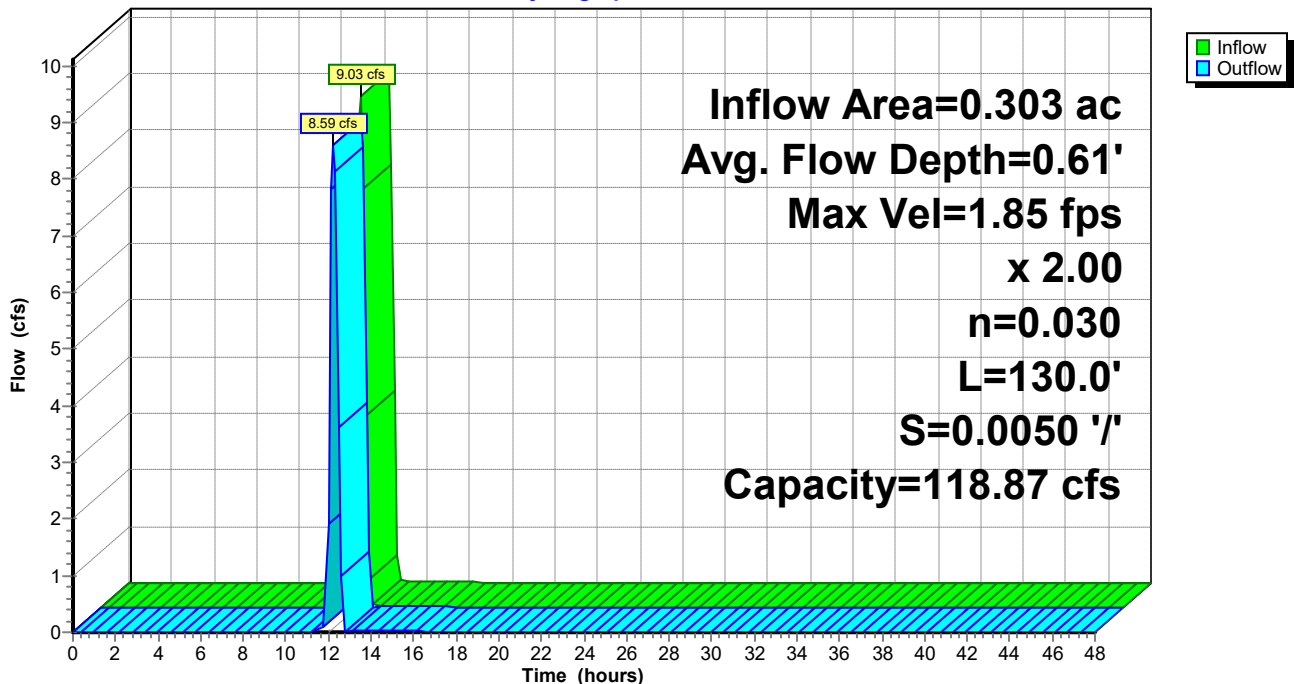

Plug Power - Proposed Conditions 5-15-21

Type II 24-hr 10-yr Rainfall=3.04"

Prepared by {enter your company name here}

Printed 5/20/2021

HydroCAD® 10.10-5a s/n 11585 © 2020 HydroCAD Software Solutions LLC

Page 126

Summary for Reach 52R: West Swale to Bio-Retention Area

Inflow Area = 22.492 ac, 55.62% Impervious, Inflow Depth = 1.09" for 10-yr event
Inflow = 16.08 cfs @ 12.07 hrs, Volume= 2.050 af
Outflow = 15.25 cfs @ 12.18 hrs, Volume= 2.050 af, Atten= 5%, Lag= 6.5 min

Routing by Dyn-Stor-Ind method, Time Span= 0.00-48.00 hrs, dt= 0.15 hrs
Max. Velocity= 0.44 fps, Min. Travel Time= 6.8 min
Avg. Velocity = 0.12 fps, Avg. Travel Time= 24.4 min

Peak Storage= 6,225 cf @ 12.18 hrs
Average Depth at Peak Storage= 2.48' , Surface Width= 23.86'
Bank-Full Depth= 3.00' Flow Area= 48.0 sf, Capacity= 23.67 cfs

4.00' x 3.00' deep channel, n= 0.300
Side Slope Z-value= 4.0 ' / ' Top Width= 28.00'
Length= 180.0' Slope= 0.0050 ' / '
Inlet Invert= 663.90', Outlet Invert= 663.00'



Reach 52R: West Swale to Bio-Retention Area

Hydrograph

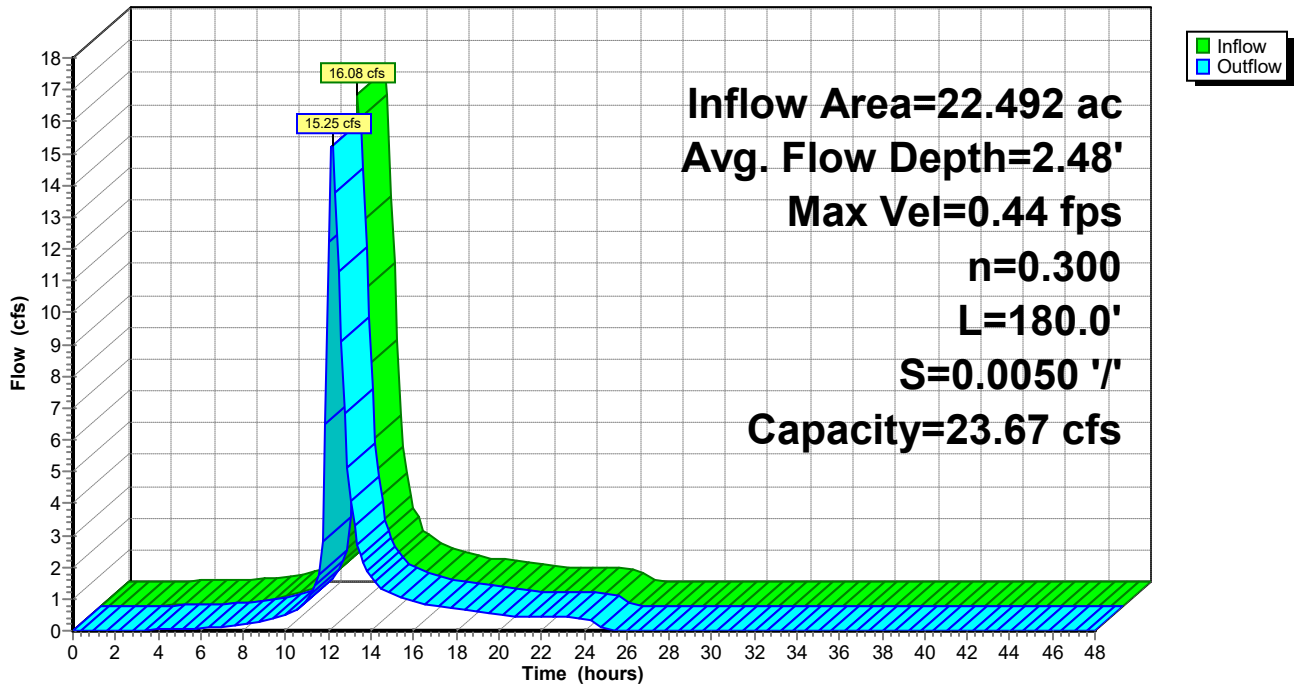

Plug Power - Proposed Conditions 5-15-21

Type II 24-hr 10-yr Rainfall=3.04"

Prepared by {enter your company name here}

Printed 5/20/2021

HydroCAD® 10.10-5a s/n 11585 © 2020 HydroCAD Software Solutions LLC

Page 127

Summary for Pond 11P: CB#1

Inflow Area = 0.442 ac, 67.06% Impervious, Inflow Depth = 2.20" for 10-yr event
 Inflow = 1.17 cfs @ 12.03 hrs, Volume= 0.081 af
 Outflow = 1.17 cfs @ 12.03 hrs, Volume= 0.081 af, Atten= 0%, Lag= 0.0 min
 Primary = 1.17 cfs @ 12.03 hrs, Volume= 0.081 af

Routing by Dyn-Stor-Ind method, Time Span= 0.00-48.00 hrs, dt= 0.15 hrs
 Peak Elev= 668.34' @ 12.19 hrs
 Flood Elev= 672.65'

Device	Routing	Invert	Outlet Devices
#1	Primary	667.41'	12.0" Round Culvert L= 137.0' CPP, square edge headwall, Ke= 0.500 Inlet / Outlet Invert= 667.41' / 667.14' S= 0.0020 '/ Cc= 0.900 n= 0.012, Flow Area= 0.79 sf

Primary OutFlow Max=0.27 cfs @ 12.03 hrs HW=668.22' TW=668.20' (Dynamic Tailwater)
 ↑1=Culvert (Outlet Controls 0.27 cfs @ 0.54 fps)

Pond 11P: CB#1

Hydrograph

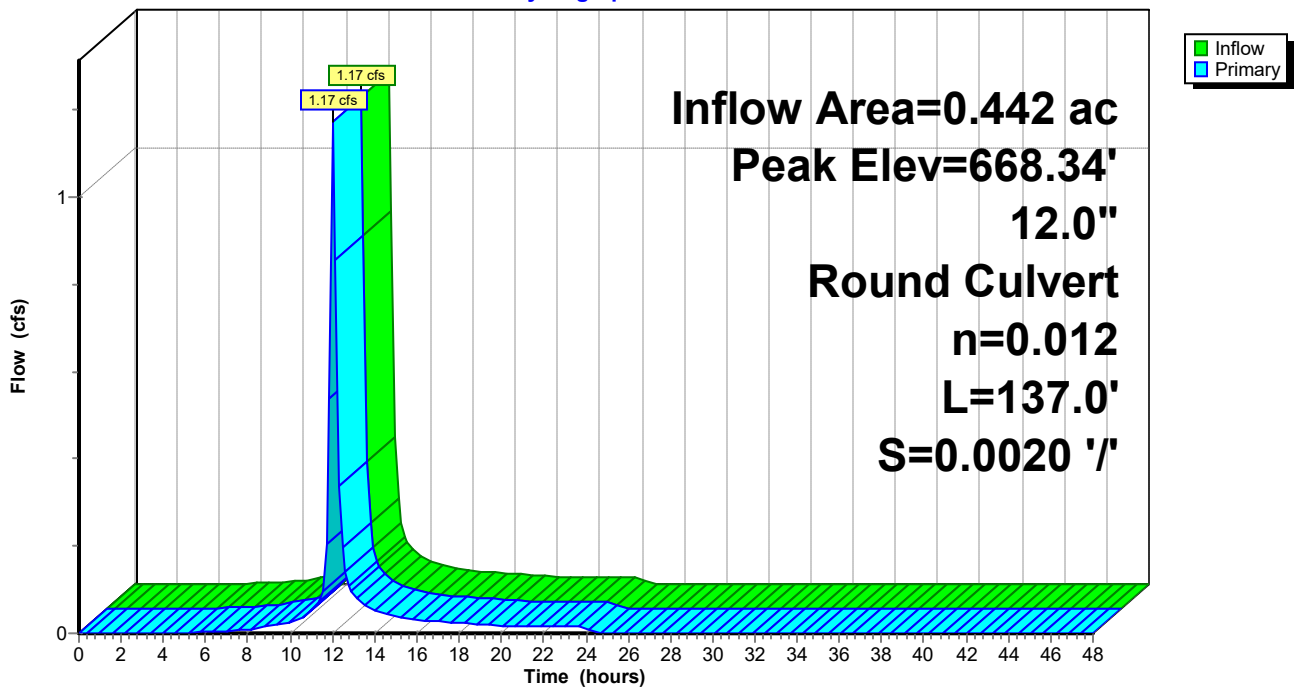

Plug Power - Proposed Conditions 5-15-21

Type II 24-hr 10-yr Rainfall=3.04"

Prepared by {enter your company name here}

Printed 5/20/2021

HydroCAD® 10.10-5a s/n 11585 © 2020 HydroCAD Software Solutions LLC

Page 128

Summary for Pond 13P: CB#3

Inflow Area = 0.724 ac, 59.47% Impervious, Inflow Depth = 2.10" for 10-yr event
Inflow = 1.84 cfs @ 12.03 hrs, Volume= 0.127 af
Outflow = 1.84 cfs @ 12.03 hrs, Volume= 0.127 af, Atten= 0%, Lag= 0.0 min
Primary = 1.84 cfs @ 12.03 hrs, Volume= 0.127 af

Routing by Dyn-Stor-Ind method, Time Span= 0.00-48.00 hrs, dt= 0.15 hrs

Peak Elev= 668.27' @ 12.15 hrs

Flood Elev= 672.65'

Device	Routing	Invert	Outlet Devices
#1	Primary	667.14'	12.0" Round Culvert L= 213.0' CPP, square edge headwall, Ke= 0.500 Inlet / Outlet Invert= 667.14' / 666.71' S= 0.0020 '/ Cc= 0.900 n= 0.012, Flow Area= 0.79 sf

Primary OutFlow Max=1.07 cfs @ 12.03 hrs HW=668.20' TW=667.97' (Dynamic Tailwater)
↑1=Culvert (Outlet Controls 1.07 cfs @ 1.59 fps)

Pond 13P: CB#3

Hydrograph

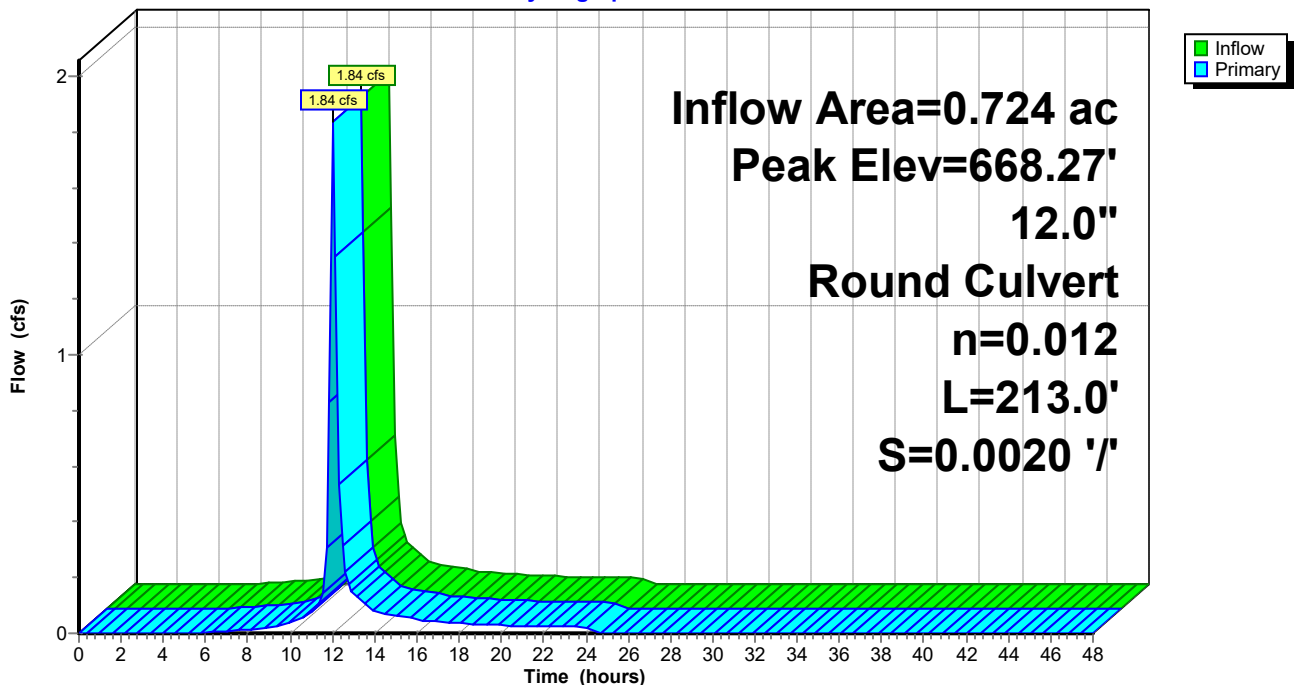

Plug Power - Proposed Conditions 5-15-21

Type II 24-hr 10-yr Rainfall=3.04"

Prepared by {enter your company name here}

Printed 5/20/2021

HydroCAD® 10.10-5a s/n 11585 © 2020 HydroCAD Software Solutions LLC

Page 129

Summary for Pond 15P: CB#5

Inflow Area = 3.805 ac, 39.15% Impervious, Inflow Depth = 1.77" for 10-yr event
Inflow = 6.31 cfs @ 12.14 hrs, Volume= 0.561 af
Outflow = 6.31 cfs @ 12.14 hrs, Volume= 0.561 af, Atten= 0%, Lag= 0.0 min
Primary = 6.31 cfs @ 12.14 hrs, Volume= 0.561 af

Routing by Dyn-Stor-Ind method, Time Span= 0.00-48.00 hrs, dt= 0.15 hrs

Peak Elev= 668.13' @ 12.14 hrs

Flood Elev= 670.95'

Device	Routing	Invert	Outlet Devices
#1	Primary	666.71'	24.0" Round Culvert L= 180.0' CPP, square edge headwall, Ke= 0.500 Inlet / Outlet Invert= 666.71' / 666.35' S= 0.0020 '/' Cc= 0.900 n= 0.012, Flow Area= 3.14 sf

Primary OutFlow Max=6.24 cfs @ 12.14 hrs HW=668.12' TW=666.93' (Dynamic Tailwater)
↑1=Culvert (Barrel Controls 6.24 cfs @ 3.71 fps)

Pond 15P: CB#5

Hydrograph

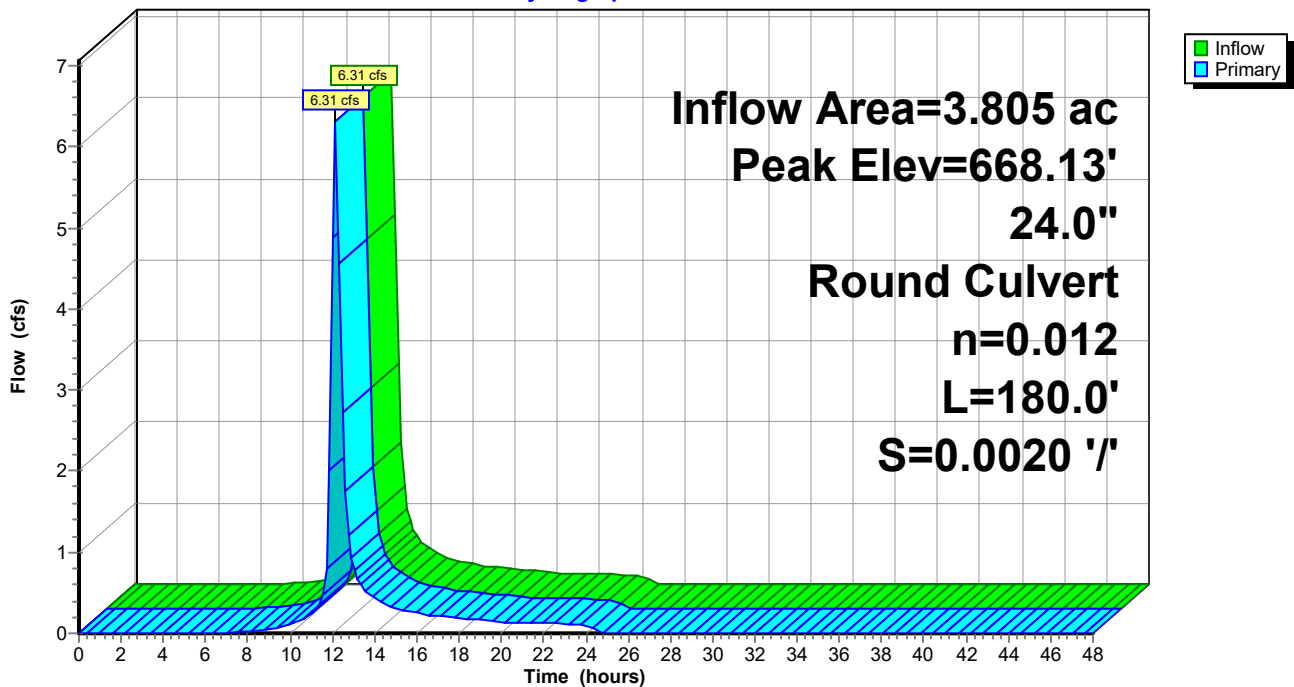

Plug Power - Proposed Conditions 5-15-21

Type II 24-hr 10-yr Rainfall=3.04"

Prepared by {enter your company name here}

Printed 5/20/2021

HydroCAD® 10.10-5a s/n 11585 © 2020 HydroCAD Software Solutions LLC

Page 130

Summary for Pond 19P: YD#22

Inflow Area = 0.624 ac, 27.67% Impervious, Inflow Depth = 1.41" for 10-yr event
 Inflow = 0.86 cfs @ 12.18 hrs, Volume= 0.073 af
 Outflow = 0.86 cfs @ 12.18 hrs, Volume= 0.073 af, Atten= 0%, Lag= 0.0 min
 Primary = 0.86 cfs @ 12.18 hrs, Volume= 0.073 af

Routing by Dyn-Stor-Ind method, Time Span= 0.00-48.00 hrs, dt= 0.15 hrs
 Peak Elev= 667.24' @ 12.17 hrs Surf.Area= 1 sf Storage= 2 cf
 Flood Elev= 669.45' Surf.Area= 17,680 sf Storage= 5,217 cf

Plug-Flow detention time= (not calculated: outflow precedes inflow)
 Center-of-Mass det. time= 0.1 min (851.8 - 851.7)

Volume	Invert	Avail.Storage	Storage Description
#1	665.26'	5,217 cf	Custom Stage Data (Prismatic) Listed below (Recalc)
Elevation (feet)	Surf.Area (sq-ft)	Inc.Store (cubic-feet)	Cum.Store (cubic-feet)
665.26	1	0	0
668.55	1	3	3
669.00	2,745	618	621
669.45	17,680	4,596	5,217

Device	Routing	Invert	Outlet Devices
#1	Primary	665.26'	10.0" Round Culvert L= 70.0' CPP, square edge headwall, Ke= 0.500 Inlet / Outlet Invert= 665.26' / 665.12' S= 0.0020 '/' Cc= 0.900 n= 0.012, Flow Area= 0.55 sf

Primary OutFlow Max=1.26 cfs @ 12.18 hrs HW=667.17' TW=666.85' (Dynamic Tailwater)
 ↑**1=Culvert** (Outlet Controls 1.26 cfs @ 2.31 fps)

Pond 19P: YD#22

Hydrograph

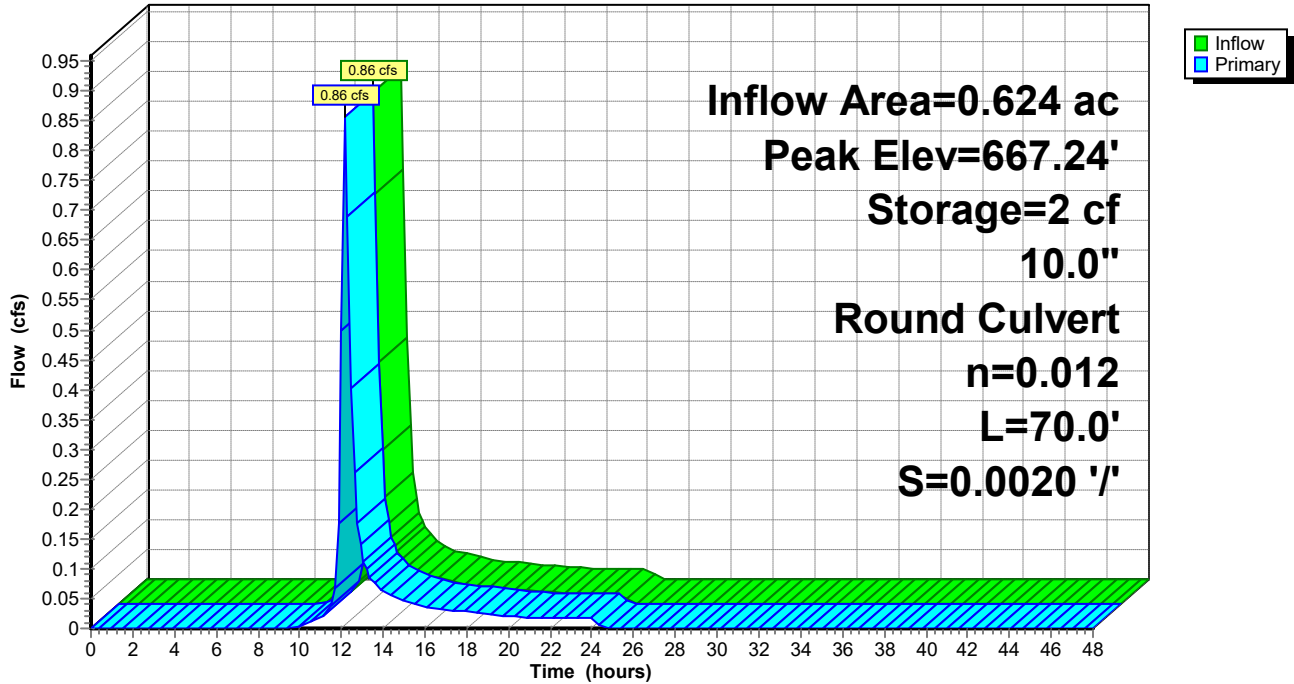

Plug Power - Proposed Conditions 5-15-21

Type II 24-hr 10-yr Rainfall=3.04"

Prepared by {enter your company name here}

Printed 5/20/2021

HydroCAD® 10.10-5a s/n 11585 © 2020 HydroCAD Software Solutions LLC

Page 132

Summary for Pond 21P: Subsurface Detention within Gravel Area

Inflow Area = 22.356 ac, 55.95% Impervious, Inflow Depth = 2.03" for 10-yr event
 Inflow = 36.97 cfs @ 12.06 hrs, Volume= 3.787 af
 Outflow = 33.48 cfs @ 12.16 hrs, Volume= 3.787 af, Atten= 9%, Lag= 6.1 min
 Primary = 15.88 cfs @ 12.07 hrs, Volume= 2.036 af
 Secondary = 9.85 cfs @ 12.12 hrs, Volume= 1.487 af
 Tertiary = 8.89 cfs @ 12.20 hrs, Volume= 0.264 af

Routing by Dyn-Stor-Ind method, Time Span= 0.00-48.00 hrs, dt= 0.15 hrs
 Peak Elev= 667.00' @ 12.21 hrs Surf.Area= 8,430 sf Storage= 8,593 cf
 Flood Elev= 668.95' Surf.Area= 129,465 sf Storage= 49,282 cf

Plug-Flow detention time= 4.2 min calculated for 3.775 af (100% of inflow)
 Center-of-Mass det. time= 4.2 min (817.0 - 812.7)

Volume	Invert	Avail.Storage	Storage Description
#1	664.01'	9,879 cf	Custom Stage Data (Prismatic) Listed below (Recalc) 30,436 cf Overall - 5,739 cf Embedded = 24,697 cf x 40.0% Voids
#2	664.01'	126 cf	24.0" Round Pipe Storage Inside #1 L= 40.0'
#3	664.01'	3,657 cf	24.0" Round Pipe Storage Inside #1 L= 1,164.0' S= 0.0020 '/'
#4	664.01'	1,421 cf	18.0" Round Pipe Storage Inside #1 L= 804.0' S= 0.0020 '/'
#5	665.61'	209 cf	15.0" Round Pipe Storage Inside #1 L= 170.0' S= 0.0020 '/'
#6	665.95'	202 cf	12.0" Round Pipe Storage Inside #1 L= 257.0' S= 0.0020 '/'
#7	666.46'	38 cf	10.0" Round Pipe Storage Inside #1 L= 69.0' S= 0.0020 '/'
#8	666.35'	88 cf	10.0" Round Pipe Storage Inside #1 L= 161.0' S= 0.0020 '/'
#9	668.02'	33,664 cf	Custom Stage Data (Prismatic) Listed below (Recalc) 84,161 cf Overall x 40.0% Voids
		49,282 cf	Total Available Storage

Elevation (feet)	Surf.Area (sq-ft)	Inc.Store (cubic-feet)	Cum.Store (cubic-feet)
664.01	3	0	0
666.67	8,430	11,216	11,216
668.95	8,430	19,220	30,436

Elevation (feet)	Surf.Area (sq-ft)	Inc.Store (cubic-feet)	Cum.Store (cubic-feet)
668.02	0	0	0
668.18	33,970	2,718	2,718
668.45	121,035	20,926	23,643
668.95	121,035	60,518	84,161

Plug Power - Proposed Conditions 5-15-21

Type II 24-hr 10-yr Rainfall=3.04"

Prepared by {enter your company name here}

Printed 5/20/2021

HydroCAD® 10.10-5a s/n 11585 © 2020 HydroCAD Software Solutions LLC

Page 133

Device	Routing	Invert	Outlet Devices
#1	Primary	664.01'	18.0" Round Culvert X 2.00 L= 57.0' CPP, square edge headwall, Ke= 0.500 Inlet / Outlet Invert= 664.01' / 663.90' S= 0.0019' / Cc= 0.900 n= 0.012, Flow Area= 1.77 sf
#2	Secondary	664.01'	18.0" Round Culvert L= 57.0' CPP, square edge headwall, Ke= 0.500 Inlet / Outlet Invert= 664.01' / 663.90' S= 0.0019' / Cc= 0.900 n= 0.012, Flow Area= 1.77 sf
#3	Tertiary	665.95'	18.0" Round Culvert X 3.00 L= 50.0' CPP, square edge headwall, Ke= 0.500 Inlet / Outlet Invert= 665.95' / 665.85' S= 0.0020' / Cc= 0.900 n= 0.012, Flow Area= 1.77 sf

Primary OutFlow Max=10.89 cfs @ 12.07 hrs HW=666.67' TW=666.26' (Dynamic Tailwater)

←**1=Culvert** (Inlet Controls 10.89 cfs @ 3.08 fps)

Secondary OutFlow Max=8.56 cfs @ 12.12 hrs HW=666.85' TW=665.84' (Dynamic Tailwater)

←**2=Culvert** (Inlet Controls 8.56 cfs @ 4.84 fps)

Tertiary OutFlow Max=8.01 cfs @ 12.20 hrs HW=666.93' TW=666.43' (Dynamic Tailwater)

←**3=Culvert** (Barrel Controls 8.01 cfs @ 3.11 fps)

Pond 21P: Subsurface Detention within Gravel Area

Hydrograph

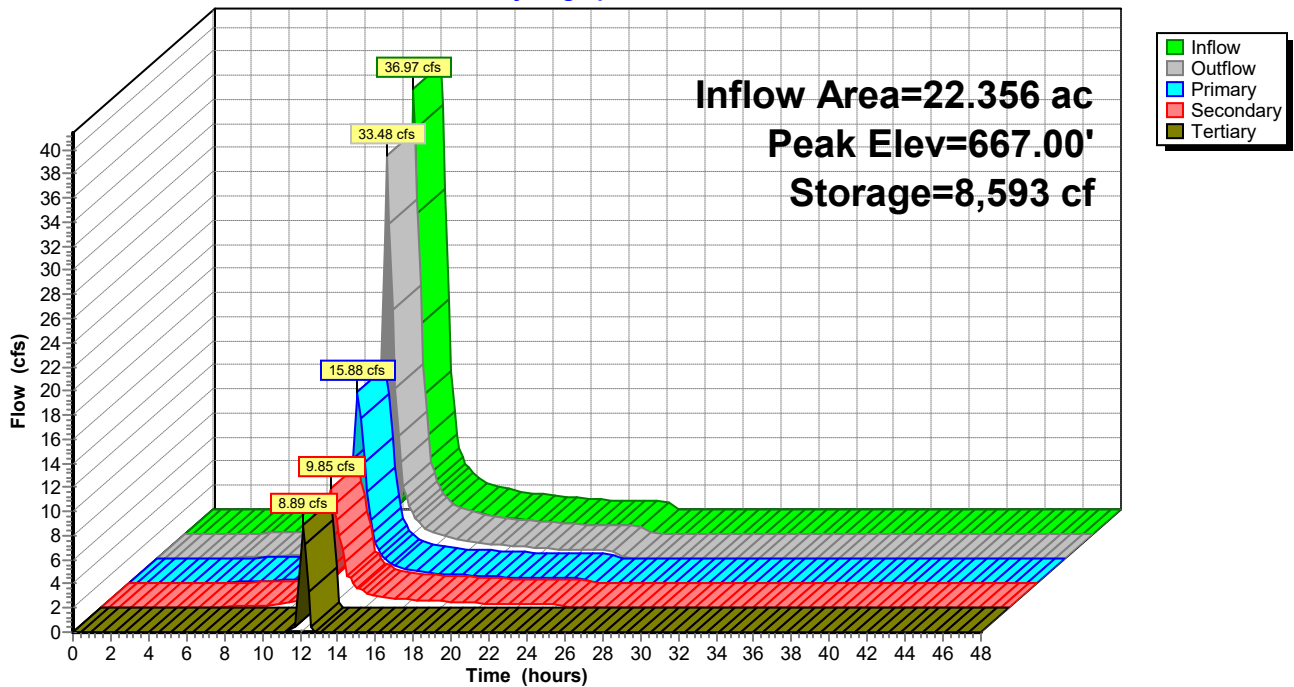

Plug Power - Proposed Conditions 5-15-21

Type II 24-hr 10-yr Rainfall=3.04"

Prepared by {enter your company name here}

Printed 5/20/2021

HydroCAD® 10.10-5a s/n 11585 © 2020 HydroCAD Software Solutions LLC

Page 134

Summary for Pond 22P: Bio-Retention Area

Inflow Area = 24.268 ac, 51.54% Impervious, Inflow Depth = 1.84" for 10-yr event
 Inflow = 25.24 cfs @ 12.17 hrs, Volume= 3.726 af
 Outflow = 10.54 cfs @ 12.89 hrs, Volume= 3.727 af, Atten= 58%, Lag= 42.9 min
 Primary = 10.54 cfs @ 12.89 hrs, Volume= 3.727 af
 Secondary = 0.00 cfs @ 0.00 hrs, Volume= 0.000 af

Routing by Dyn-Stor-Ind method, Time Span= 0.00-48.00 hrs, dt= 0.15 hrs
 Peak Elev= 664.34' @ 12.89 hrs Surf.Area= 58,244 sf Storage= 71,144 cf

Plug-Flow detention time= 415.9 min calculated for 3.715 af (100% of inflow)
 Center-of-Mass det. time= 417.8 min (1,253.2 - 835.4)

Volume	Invert	Avail.Storage	Storage Description
#1	663.00'	95,677 cf	Custom Stage Data (Prismatic) Listed below (Recalc)
Elevation (feet)	Surf.Area (sq-ft)	Inc.Store (cubic-feet)	Cum.Store (cubic-feet)
663.00	48,935	0	0
663.25	50,025	12,370	12,370
663.50	51,115	12,643	25,013
664.00	56,110	26,806	51,819
664.75	60,845	43,858	95,677

Device	Routing	Invert	Outlet Devices
#1	Primary	660.55'	15.0" Round Culvert L= 25.0' CPP, square edge headwall, Ke= 0.500 Inlet / Outlet Invert= 660.55' / 660.50' S= 0.0020 '/' Cc= 0.900 n= 0.012, Flow Area= 1.23 sf
#2	Primary	660.55'	15.0" Round Culvert L= 25.0' CPP, square edge headwall, Ke= 0.500 Inlet / Outlet Invert= 660.55' / 660.50' S= 0.0020 '/' Cc= 0.900 n= 0.012, Flow Area= 1.23 sf
#3	Device 1	660.56'	4.0" Round Culvert L= 5.0' CPP, square edge headwall, Ke= 0.500 Inlet / Outlet Invert= 660.56' / 660.55' S= 0.0020 '/' Cc= 0.900 n= 0.012, Flow Area= 0.09 sf
#4	Device 2	660.56'	4.0" Round Culvert L= 5.0' CPP, square edge headwall, Ke= 0.500 Inlet / Outlet Invert= 660.56' / 660.55' S= 0.0020 '/' Cc= 0.900 n= 0.012, Flow Area= 0.09 sf
#5	Device 3	663.00'	0.500 in/hr Exfiltration X 0.50 over Surface area
#6	Device 4	663.00'	0.500 in/hr Exfiltration X 0.50 over Surface area
#7	Device 3	663.50'	4.0" Horiz. Orifice/Grate X 4.00 C= 0.600 Limited to weir flow at low heads
#8	Device 4	663.50'	4.0" Horiz. Orifice/Grate X 3.00 C= 0.600 Limited to weir flow at low heads
#9	Device 1	664.25'	1.4" x 4.5" Horiz. Orifice/Grate X 72.00 C= 0.600 Limited to weir flow at low heads
#10	Device 2	664.25'	1.4" x 4.5" Horiz. Orifice/Grate X 72.00 C= 0.600 Limited to weir flow at low heads
#11	Secondary	664.50'	100.0' long x 2.0' breadth Broad-Crested Rectangular Weir

Plug Power - Proposed Conditions 5-15-21

Type II 24-hr 10-yr Rainfall=3.04"

Prepared by {enter your company name here}

Printed 5/20/2021

HydroCAD® 10.10-5a s/n 11585 © 2020 HydroCAD Software Solutions LLC

Page 135

Head (feet)	0.20	0.40	0.60	0.80	1.00	1.20	1.40	1.60	1.80	2.00
	2.50	3.00	3.50							
Coef. (English)	2.54	2.61	2.61	2.60	2.66	2.70	2.77	2.89	2.88	
	2.85	3.07	3.20	3.32						

Primary OutFlow Max=10.46 cfs @ 12.89 hrs HW=664.34' TW=661.13' (Dynamic Tailwater)

- 1=Culvert (Passes 5.23 cfs of 10.51 cfs potential flow)
- 3=Culvert (Inlet Controls 0.75 cfs @ 8.62 fps)
- 5=Exfiltration (Passes < 0.34 cfs potential flow)
- 7=Orifice/Grate (Passes < 1.54 cfs potential flow)
- 9=Orifice/Grate (Orifice Controls 4.48 cfs @ 1.42 fps)
- 2=Culvert (Passes 5.23 cfs of 10.51 cfs potential flow)
- 4=Culvert (Inlet Controls 0.75 cfs @ 8.62 fps)
- 6=Exfiltration (Passes < 0.34 cfs potential flow)
- 8=Orifice/Grate (Passes < 1.15 cfs potential flow)
- 10=Orifice/Grate (Orifice Controls 4.48 cfs @ 1.42 fps)

Secondary OutFlow Max=0.00 cfs @ 0.00 hrs HW=663.00' TW=660.30' (Dynamic Tailwater)

- 11=Broad-Crested Rectangular Weir (Controls 0.00 cfs)

Pond 22P: Bio-Retention Area

Hydrograph

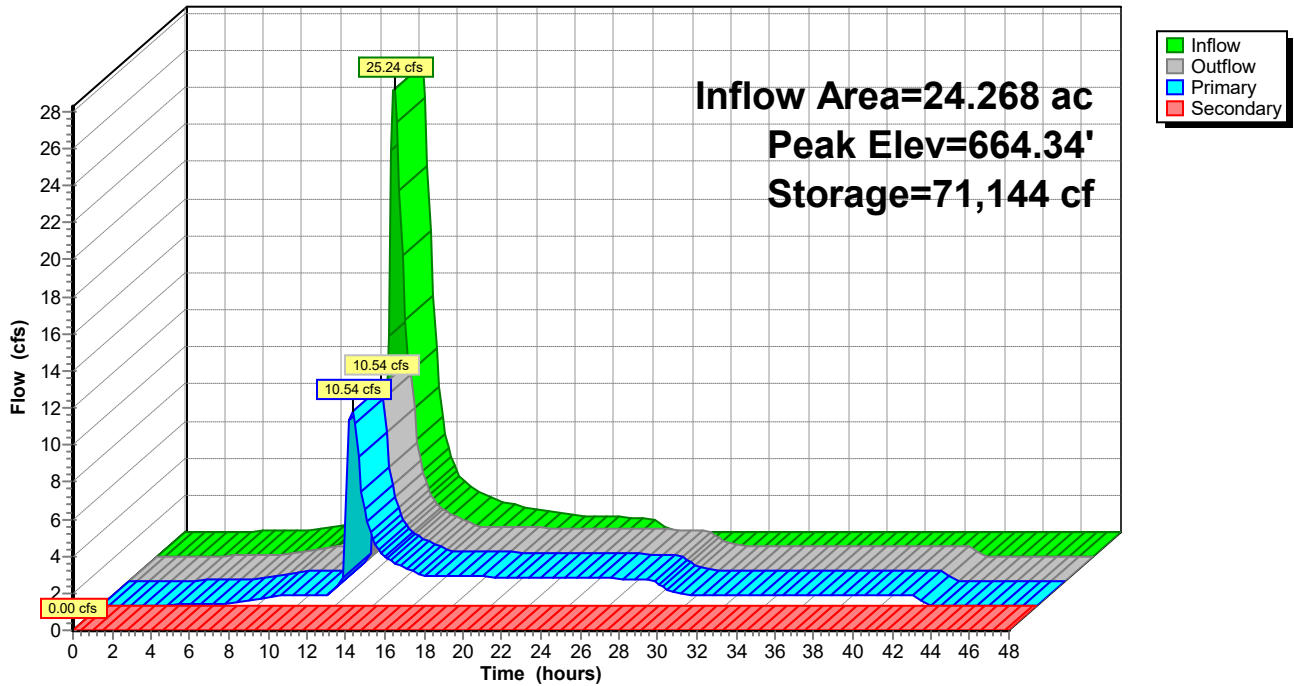

Plug Power - Proposed Conditions 5-15-21

Type II 24-hr 10-yr Rainfall=3.04"

Prepared by {enter your company name here}

Printed 5/20/2021

HydroCAD® 10.10-5a s/n 11585 © 2020 HydroCAD Software Solutions LLC

Page 136

Summary for Pond 25P: YD#11

Inflow Area = 0.893 ac, 53.89% Impervious, Inflow Depth = 2.02" for 10-yr event
Inflow = 1.95 cfs @ 12.11 hrs, Volume= 0.150 af
Outflow = 1.95 cfs @ 12.11 hrs, Volume= 0.150 af, Atten= 0%, Lag= 0.0 min
Primary = 1.95 cfs @ 12.11 hrs, Volume= 0.150 af

Routing by Dyn-Stor-Ind method, Time Span= 0.00-48.00 hrs, dt= 0.15 hrs
Peak Elev= 667.92' @ 12.18 hrs Surf.Area= 1 sf Storage= 2 cf
Flood Elev= 669.70' Surf.Area= 3,725 sf Storage= 1,028 cf

Plug-Flow detention time= 0.0 min calculated for 0.150 af (100% of inflow)
Center-of-Mass det. time= 0.0 min (816.3 - 816.3)

Volume	Invert	Avail.Storage	Storage Description
#1	666.25'	1,028 cf	Custom Stage Data (Prismatic) Listed below (Recalc)

Elevation (feet)	Surf.Area (sq-ft)	Inc.Store (cubic-feet)	Cum.Store (cubic-feet)
666.25	1	0	0
669.15	1	3	3
669.70	3,725	1,025	1,028

Device	Routing	Invert	Outlet Devices
#1	Primary	666.25'	12.0" Round Culvert L= 170.0' CPP, square edge headwall, Ke= 0.500 Inlet / Outlet Invert= 666.25' / 665.91' S= 0.0020 '/' Cc= 0.900 n= 0.012, Flow Area= 0.79 sf

Primary OutFlow Max=1.29 cfs @ 12.11 hrs HW=667.73' TW=667.48' (Dynamic Tailwater)
↑**1=Culvert** (Outlet Controls 1.29 cfs @ 1.64 fps)

Pond 25P: YD#11

Hydrograph

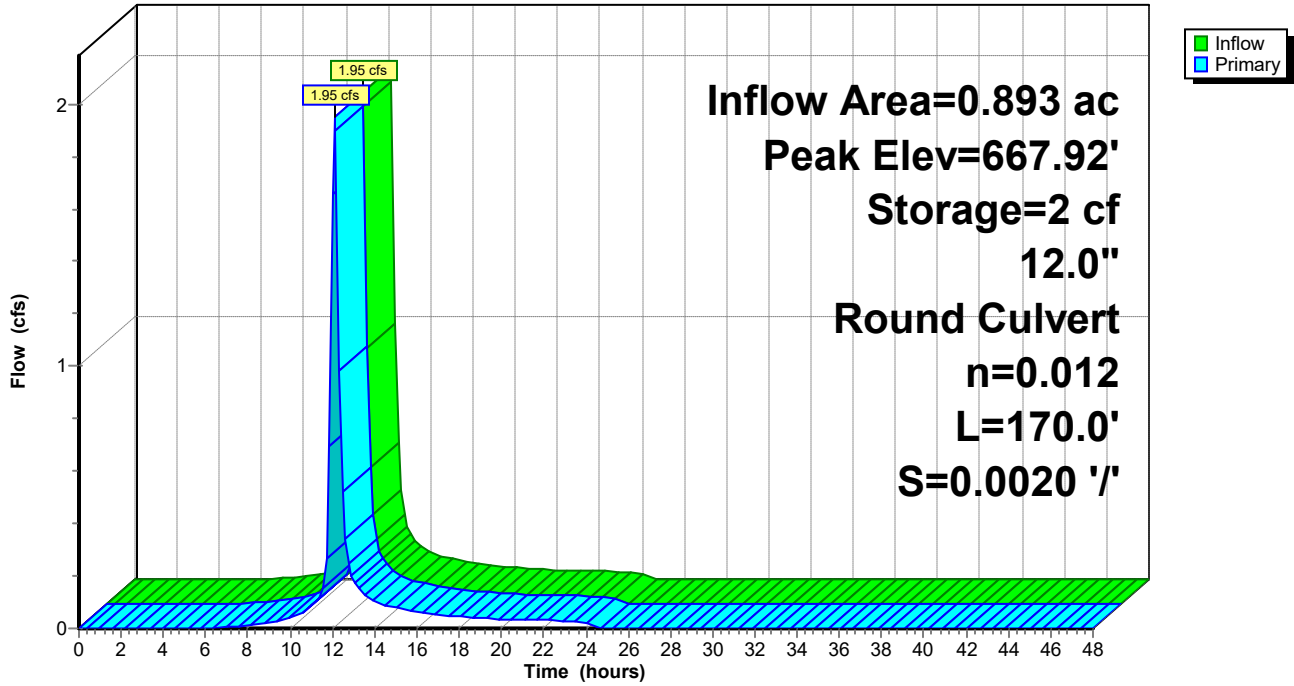

Plug Power - Proposed Conditions 5-15-21

Type II 24-hr 10-yr Rainfall=3.04"

Prepared by {enter your company name here}

Printed 5/20/2021

HydroCAD® 10.10-5a s/n 11585 © 2020 HydroCAD Software Solutions LLC

Page 138

Summary for Pond 27P: CB#4

Inflow Area = 0.946 ac, 62.20% Impervious, Inflow Depth = 2.11" for 10-yr event
 Inflow = 2.15 cfs @ 12.10 hrs, Volume= 0.166 af
 Outflow = 2.14 cfs @ 12.10 hrs, Volume= 0.166 af, Atten= 0%, Lag= 0.0 min
 Primary = 2.14 cfs @ 12.10 hrs, Volume= 0.166 af

Routing by Dyn-Stor-Ind method, Time Span= 0.00-48.00 hrs, dt= 0.15 hrs
 Peak Elev= 667.65' @ 12.15 hrs Surf.Area= 4 sf Storage= 7 cf
 Flood Elev= 669.15' Surf.Area= 5,345 sf Storage= 1,597 cf

Plug-Flow detention time= 2.3 min calculated for 0.166 af (100% of inflow)
 Center-of-Mass det. time= 0.2 min (811.6 - 811.4)

Volume	Invert	Avail.Storage	Storage Description
#1	665.99'	1,597 cf	Custom Stage Data (Prismatic) Listed below (Recalc)

Elevation (feet)	Surf.Area (sq-ft)	Inc.Store (cubic-feet)	Cum.Store (cubic-feet)
665.99	4	0	0
668.40	4	10	10
669.00	3,160	949	959
669.15	5,345	638	1,597

Device	Routing	Invert	Outlet Devices
#1	Primary	665.99'	12.0" Round Culvert L= 40.0' CPP, square edge headwall, Ke= 0.500 Inlet / Outlet Invert= 665.99' / 665.91' S= 0.0020 '/' Cc= 0.900 n= 0.012, Flow Area= 0.79 sf

Primary OutFlow Max=0.03 cfs @ 12.10 hrs HW=667.47' TW=667.47' (Dynamic Tailwater)
 ↑**1=Culvert** (Inlet Controls 0.03 cfs @ 0.04 fps)

Pond 27P: CB#4

Hydrograph

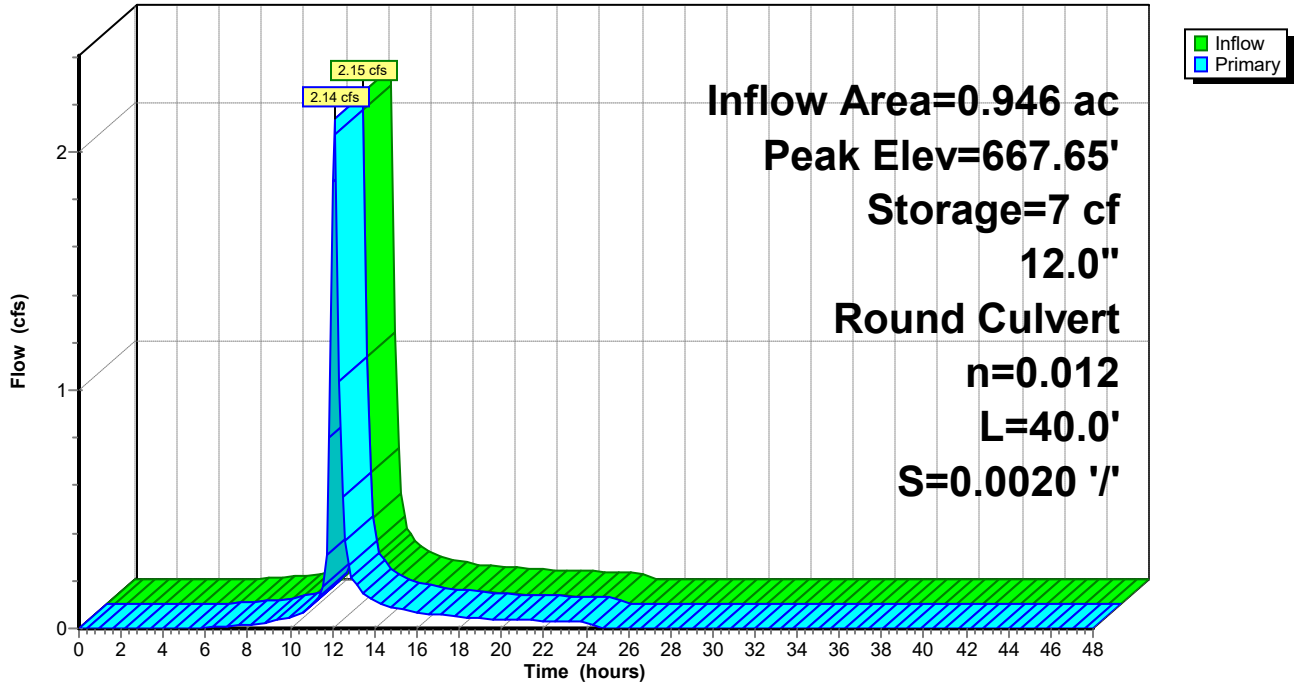

Plug Power - Proposed Conditions 5-15-21

Type II 24-hr 10-yr Rainfall=3.04"

Prepared by {enter your company name here}

Printed 5/20/2021

HydroCAD® 10.10-5a s/n 11585 © 2020 HydroCAD Software Solutions LLC

Page 140

Summary for Pond 28P: CB#15

Inflow Area = 2.230 ac, 65.51% Impervious, Inflow Depth = 2.20" for 10-yr event
 Inflow = 4.95 cfs @ 12.04 hrs, Volume= 0.408 af
 Outflow = 4.95 cfs @ 12.04 hrs, Volume= 0.408 af, Atten= 0%, Lag= 0.0 min
 Primary = 4.95 cfs @ 12.04 hrs, Volume= 0.408 af

Routing by Dyn-Stor-Ind method, Time Span= 0.00-48.00 hrs, dt= 0.15 hrs
 Peak Elev= 667.61' @ 12.27 hrs Surf.Area= 4 sf Storage= 7 cf
 Flood Elev= 669.20' Surf.Area= 4 sf Storage= 13 cf

Plug-Flow detention time= 1.3 min calculated for 0.408 af (100% of inflow)
 Center-of-Mass det. time= 0.1 min (800.2 - 800.1)

Volume	Invert	Avail.Storage	Storage Description
#1	665.91'	13 cf	Custom Stage Data (Prismatic) Listed below (Recalc)

Elevation (feet)	Surf.Area (sq-ft)	Inc.Store (cubic-feet)	Cum.Store (cubic-feet)
665.91	4	0	0
669.20	4	13	13

Device	Routing	Invert	Outlet Devices
#1	Primary	665.91'	18.0" Round Culvert L= 157.0' CPP, square edge headwall, Ke= 0.500 Inlet / Outlet Invert= 665.91' / 665.60' S= 0.0020 '/' Cc= 0.900 n= 0.012, Flow Area= 1.77 sf

Primary OutFlow Max=2.44 cfs @ 12.04 hrs HW=667.40' TW=667.25' (Dynamic Tailwater)
 ↑1=Culvert (Outlet Controls 2.44 cfs @ 1.72 fps)

Pond 28P: CB#15

Hydrograph

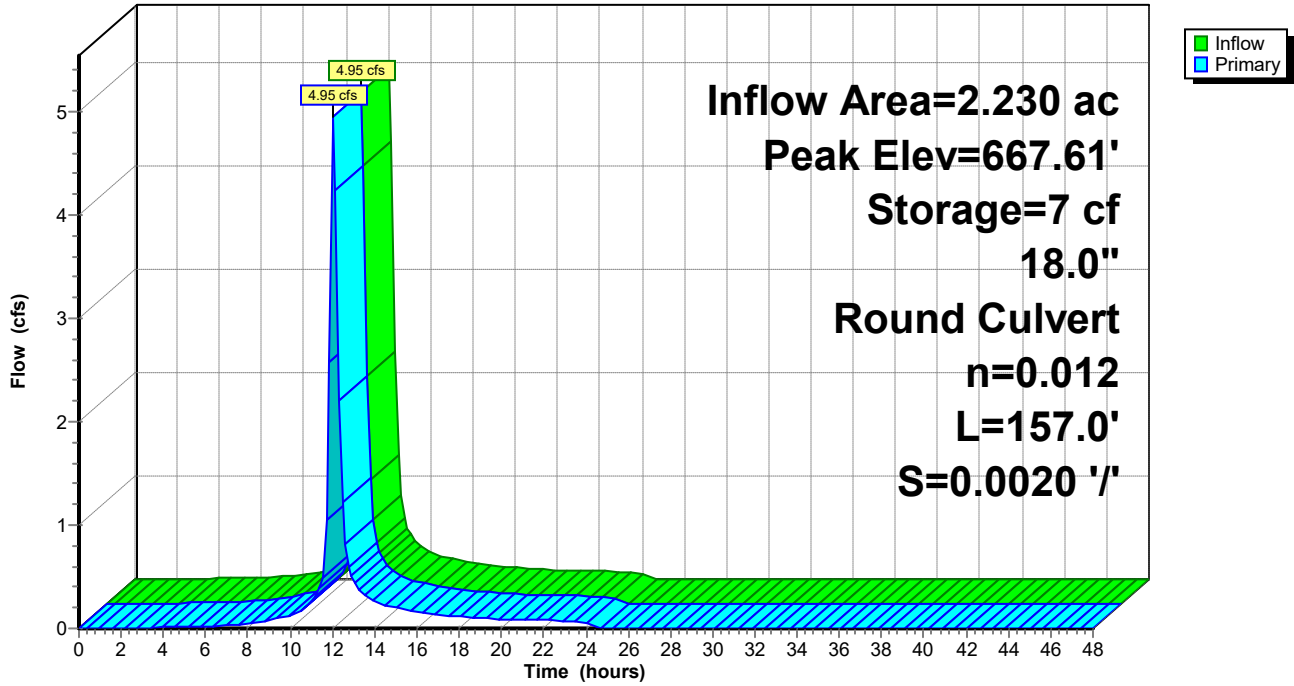

Plug Power - Proposed Conditions 5-15-21

Type II 24-hr 10-yr Rainfall=3.04"

Prepared by {enter your company name here}

Printed 5/20/2021

HydroCAD® 10.10-5a s/n 11585 © 2020 HydroCAD Software Solutions LLC

Page 142

Summary for Pond 29P: Dry Pond

Inflow Area = 0.745 ac, 0.00% Impervious, Inflow Depth = 5.54" for 10-yr event
 Inflow = 8.74 cfs @ 12.23 hrs, Volume= 0.344 af
 Outflow = 2.08 cfs @ 12.55 hrs, Volume= 0.344 af, Atten= 76%, Lag= 19.0 min
 Primary = 2.08 cfs @ 12.55 hrs, Volume= 0.344 af
 Tertiary = 0.00 cfs @ 0.00 hrs, Volume= 0.000 af

Routing by Dyn-Stor-Ind method, Time Span= 0.00-48.00 hrs, dt= 0.15 hrs
 Peak Elev= 663.98' @ 12.55 hrs Surf.Area= 10,204 sf Storage= 9,956 cf

Plug-Flow detention time= 76.9 min calculated for 0.343 af (100% of inflow)
 Center-of-Mass det. time= 77.0 min (838.0 - 761.0)

Volume	Invert	Avail.Storage	Storage Description
#1	662.56'	37,071 cf	Custom Stage Data (Prismatic) Listed below (Recalc)
Elevation (feet)	Surf.Area (sq-ft)	Inc.Store (cubic-feet)	Cum.Store (cubic-feet)
662.56	300	0	0
663.00	6,155	1,420	1,420
663.35	8,635	2,588	4,008
664.00	10,250	6,138	10,146
665.00	12,040	11,145	21,291
666.00	19,520	15,780	37,071

Device	Routing	Invert	Outlet Devices
#1	Primary	662.56'	12.0" Round Culvert L= 30.0' CPP, square edge headwall, Ke= 0.500 Inlet / Outlet Invert= 662.56' / 662.50' S= 0.0020 '/' Cc= 0.900 n= 0.012, Flow Area= 0.79 sf
#2	Primary	662.56'	12.0" Round Culvert L= 30.0' CPP, square edge headwall, Ke= 0.500 Inlet / Outlet Invert= 662.56' / 662.50' S= 0.0020 '/' Cc= 0.900 n= 0.012, Flow Area= 0.79 sf
#3	Device 1	662.56'	3.0" Vert. Orifice/Grate C= 0.600 Limited to weir flow at low heads
#4	Device 2	662.56'	3.0" Vert. Orifice/Grate C= 0.600 Limited to weir flow at low heads
#5	Device 1	663.06'	6.0" Vert. Orifice/Grate C= 0.600 Limited to weir flow at low heads
#6	Device 2	663.06'	6.0" Vert. Orifice/Grate C= 0.600 Limited to weir flow at low heads
#7	Device 1	665.20'	1.4" x 4.5" Horiz. Orifice/Grate X 72.00 C= 0.600 Limited to weir flow at low heads
#8	Device 2	665.20'	1.4" x 4.5" Horiz. Orifice/Grate X 72.00 C= 0.600 Limited to weir flow at low heads
#9	Tertiary	665.70'	100.0' long x 2.0' breadth Broad-Crested Rectangular Weir Head (feet) 0.20 0.40 0.60 0.80 1.00 1.20 1.40 1.60 1.80 2.00 2.50 3.00 3.50 Coef. (English) 2.54 2.61 2.61 2.60 2.66 2.70 2.77 2.89 2.88 2.85 3.07 3.20 3.32

Plug Power - Proposed Conditions 5-15-21

Type II 24-hr 10-yr Rainfall=3.04"

Prepared by {enter your company name here}

Printed 5/20/2021

HydroCAD® 10.10-5a s/n 11585 © 2020 HydroCAD Software Solutions LLC

Page 143

Primary OutFlow Max=2.07 cfs @ 12.55 hrs HW=663.97' TW=662.70' (Dynamic Tailwater)

- 1=Culvert (Passes 1.04 cfs of 2.85 cfs potential flow)
- 3=Orifice/Grate (Orifice Controls 0.27 cfs @ 5.44 fps)
- 5=Orifice/Grate (Orifice Controls 0.77 cfs @ 3.91 fps)
- 7=Orifice/Grate (Controls 0.00 cfs)
- 2=Culvert (Passes 1.04 cfs of 2.85 cfs potential flow)
- 4=Orifice/Grate (Orifice Controls 0.27 cfs @ 5.44 fps)
- 6=Orifice/Grate (Orifice Controls 0.77 cfs @ 3.91 fps)
- 8=Orifice/Grate (Controls 0.00 cfs)

Tertiary OutFlow Max=0.00 cfs @ 0.00 hrs HW=662.56' TW=662.30' (Dynamic Tailwater)

- 9=Broad-Crested Rectangular Weir (Controls 0.00 cfs)

Pond 29P: Dry Pond

Hydrograph

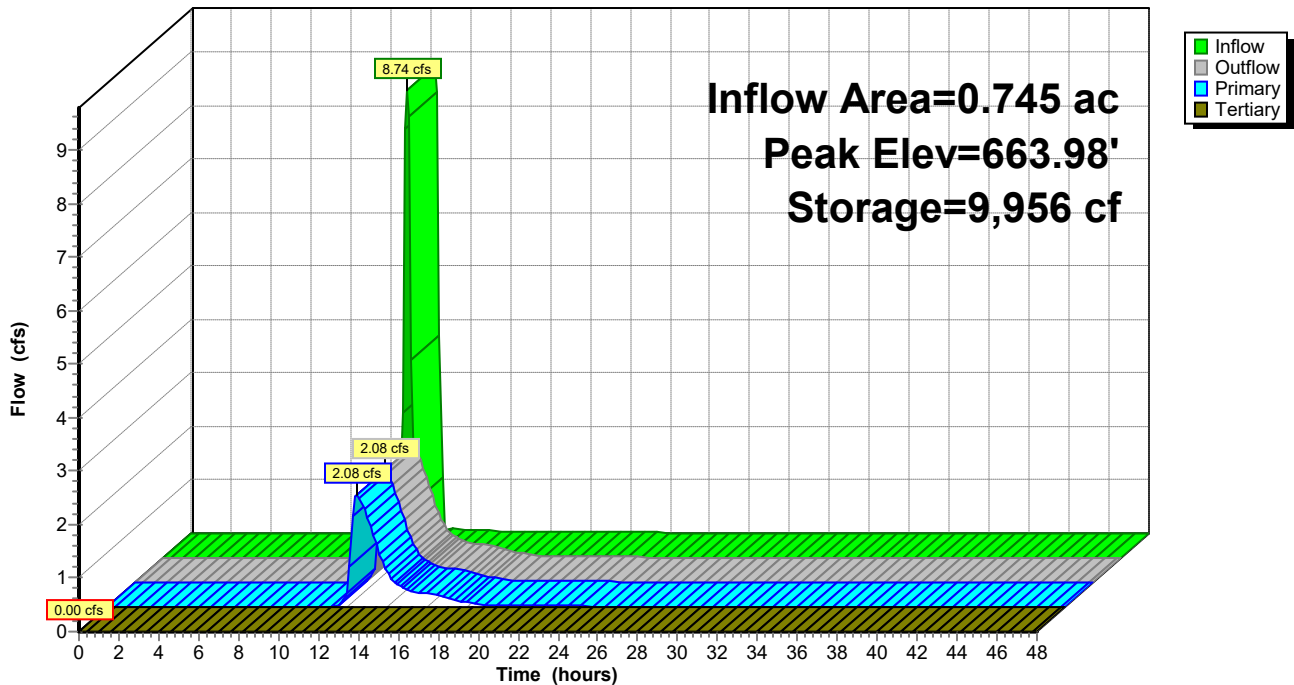

Plug Power - Proposed Conditions 5-15-21

Type II 24-hr 10-yr Rainfall=3.04"

Prepared by {enter your company name here}

Printed 5/20/2021

HydroCAD® 10.10-5a s/n 11585 © 2020 HydroCAD Software Solutions LLC

Page 144

Summary for Pond 31P: CB#18

Inflow Area = 2.692 ac, 56.86% Impervious, Inflow Depth = 2.05" for 10-yr event
Inflow = 5.37 cfs @ 12.06 hrs, Volume= 0.460 af
Outflow = 5.37 cfs @ 12.06 hrs, Volume= 0.460 af, Atten= 0%, Lag= 0.0 min
Primary = 5.37 cfs @ 12.06 hrs, Volume= 0.460 af

Routing by Dyn-Stor-Ind method, Time Span= 0.00-48.00 hrs, dt= 0.15 hrs
Peak Elev= 667.52' @ 12.19 hrs Surf.Area= 4 sf Storage= 8 cf
Flood Elev= 669.45' Surf.Area= 9,895 sf Storage= 3,378 cf

Plug-Flow detention time= (not calculated: outflow precedes inflow)
Center-of-Mass det. time= 0.1 min (806.5 - 806.4)

Volume	Invert	Avail.Storage	Storage Description
#1	665.60'	3,378 cf	Custom Stage Data (Prismatic) Listed below (Recalc)

Elevation (feet)	Surf.Area (sq-ft)	Inc.Store (cubic-feet)	Cum.Store (cubic-feet)
665.60	4	0	0
668.55	4	12	12
669.00	2,530	570	582
669.45	9,895	2,796	3,378

Device	Routing	Invert	Outlet Devices
#1	Primary	665.60'	18.0" Round Culvert L= 83.0' CPP, square edge headwall, Ke= 0.500 Inlet / Outlet Invert= 665.60' / 665.43' S= 0.0020 '/' Cc= 0.900 n= 0.012, Flow Area= 1.77 sf

Primary OutFlow Max=1.75 cfs @ 12.06 hrs HW=667.28' TW=667.23' (Dynamic Tailwater)
↑**1=Culvert** (Outlet Controls 1.75 cfs @ 1.10 fps)

Pond 31P: CB#18

Hydrograph

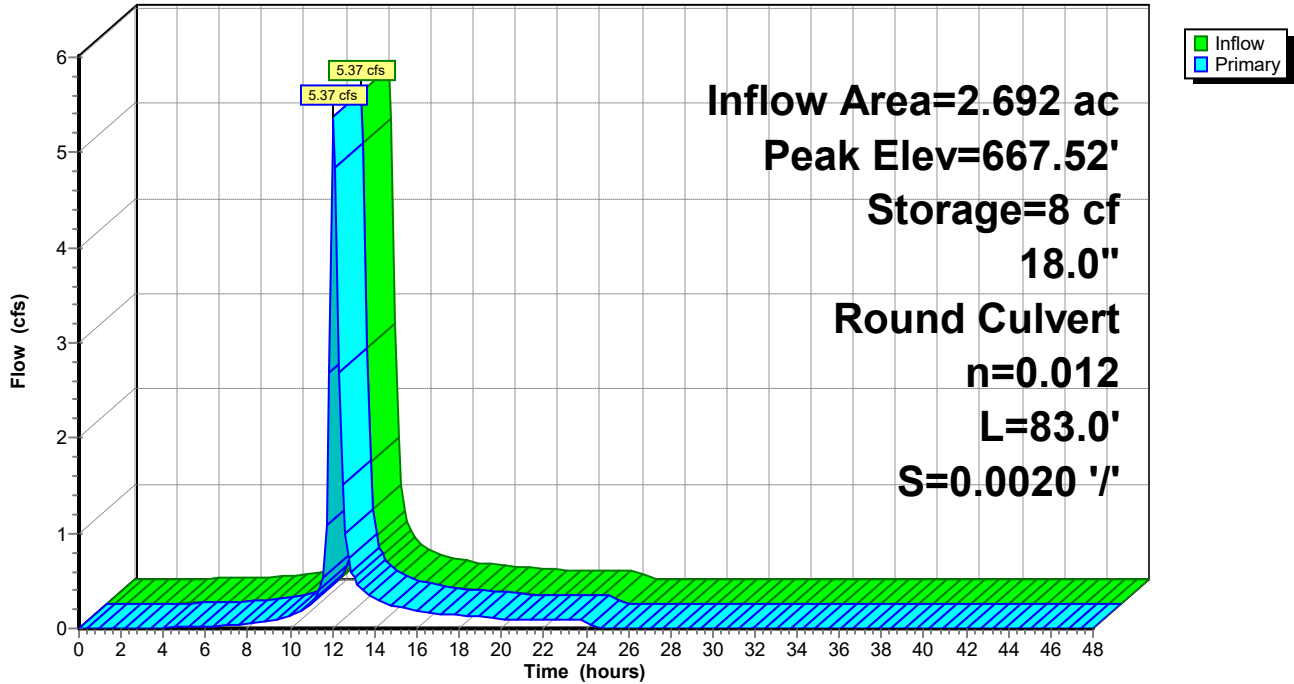

Plug Power - Proposed Conditions 5-15-21

Type II 24-hr 10-yr Rainfall=3.04"

Prepared by {enter your company name here}

Printed 5/20/2021

HydroCAD® 10.10-5a s/n 11585 © 2020 HydroCAD Software Solutions LLC

Page 146

Summary for Pond 33P: CB#26

Inflow Area = 0.831 ac, 69.35% Impervious, Inflow Depth = 2.20" for 10-yr event
 Inflow = 1.95 cfs @ 12.10 hrs, Volume= 0.152 af
 Outflow = 1.95 cfs @ 12.10 hrs, Volume= 0.152 af, Atten= 0%, Lag= 0.0 min
 Primary = 1.95 cfs @ 12.10 hrs, Volume= 0.152 af

Routing by Dyn-Stor-Ind method, Time Span= 0.00-48.00 hrs, dt= 0.15 hrs
 Peak Elev= 667.09' @ 12.78 hrs Surf.Area= 4 sf Storage= 7 cf
 Flood Elev= 669.00' Surf.Area= 3,160 sf Storage= 961 cf

Plug-Flow detention time= 0.2 min calculated for 0.152 af (100% of inflow)
 Center-of-Mass det. time= 0.2 min (806.7 - 806.6)

Volume	Invert	Avail.Storage	Storage Description
#1	665.42'	1,599 cf	Custom Stage Data (Prismatic) Listed below (Recalc)
Elevation (feet)	Surf.Area (sq-ft)	Inc.Store (cubic-feet)	Cum.Store (cubic-feet)
665.42	4	0	0
668.40	4	12	12
669.00	3,160	949	961
669.15	5,345	638	1,599

Device	Routing	Invert	Outlet Devices
#1	Primary	665.42'	12.0" Round Culvert L= 175.0' CPP, square edge headwall, Ke= 0.500 Inlet / Outlet Invert= 665.42' / 665.07' S= 0.0020 '/' Cc= 0.900 n= 0.012, Flow Area= 0.79 sf

Primary OutFlow Max=1.35 cfs @ 12.10 hrs HW=666.55' TW=666.26' (Dynamic Tailwater)
 ↑**1=Culvert** (Outlet Controls 1.35 cfs @ 1.91 fps)

Pond 33P: CB#26

Hydrograph

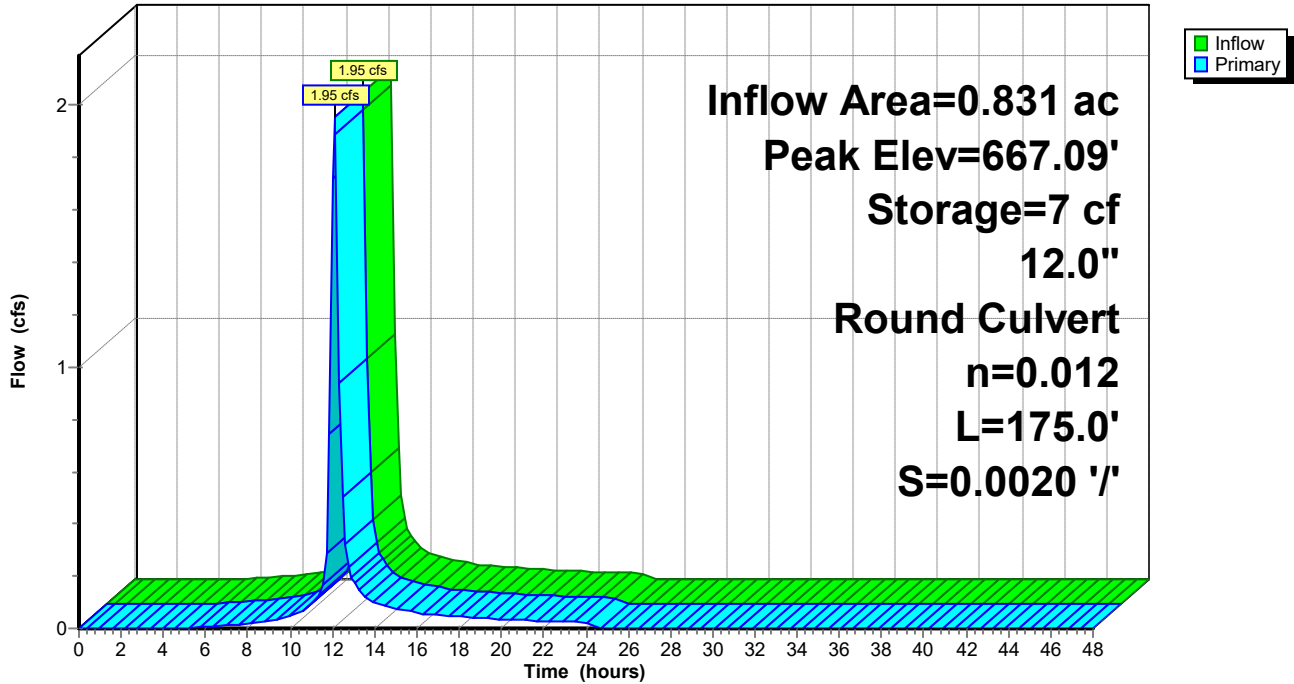

Plug Power - Proposed Conditions 5-15-21

Type II 24-hr 10-yr Rainfall=3.04"

Prepared by {enter your company name here}

Printed 5/20/2021

HydroCAD® 10.10-5a s/n 11585 © 2020 HydroCAD Software Solutions LLC

Page 148

Summary for Pond 37P: CB#28

Inflow Area = 1.256 ac, 61.06% Impervious, Inflow Depth = 2.08" for 10-yr event
 Inflow = 2.78 cfs @ 12.11 hrs, Volume= 0.218 af
 Outflow = 2.78 cfs @ 12.11 hrs, Volume= 0.218 af, Atten= 0%, Lag= 0.0 min
 Primary = 2.78 cfs @ 12.11 hrs, Volume= 0.218 af

Routing by Dyn-Stor-Ind method, Time Span= 0.00-48.00 hrs, dt= 0.15 hrs
 Peak Elev= 667.08' @ 12.63 hrs Surf.Area= 4 sf Storage= 8 cf
 Flood Elev= 669.75' Surf.Area= 5,170 sf Storage= 1,569 cf

Plug-Flow detention time= 0.1 min calculated for 0.217 af (100% of inflow)
 Center-of-Mass det. time= 0.1 min (812.8 - 812.7)

Volume	Invert	Avail.Storage	Storage Description
#1	665.07'	1,569 cf	Custom Stage Data (Prismatic) Listed below (Recalc)

Elevation (feet)	Surf.Area (sq-ft)	Inc.Store (cubic-feet)	Cum.Store (cubic-feet)
665.07	4	0	0
669.15	4	16	16
669.75	5,170	1,552	1,569

Device	Routing	Invert	Outlet Devices
#1	Primary	665.07'	15.0" Round Culvert L= 214.0' CPP, square edge headwall, Ke= 0.500 Inlet / Outlet Invert= 665.07' / 664.64' S= 0.0020 '/' Cc= 0.900 n= 0.012, Flow Area= 1.23 sf

Primary OutFlow Max=1.46 cfs @ 12.11 hrs HW=666.28' TW=666.10' (Dynamic Tailwater)
 ↑**1=Culvert** (Outlet Controls 1.46 cfs @ 1.53 fps)

Pond 37P: CB#28

Hydrograph

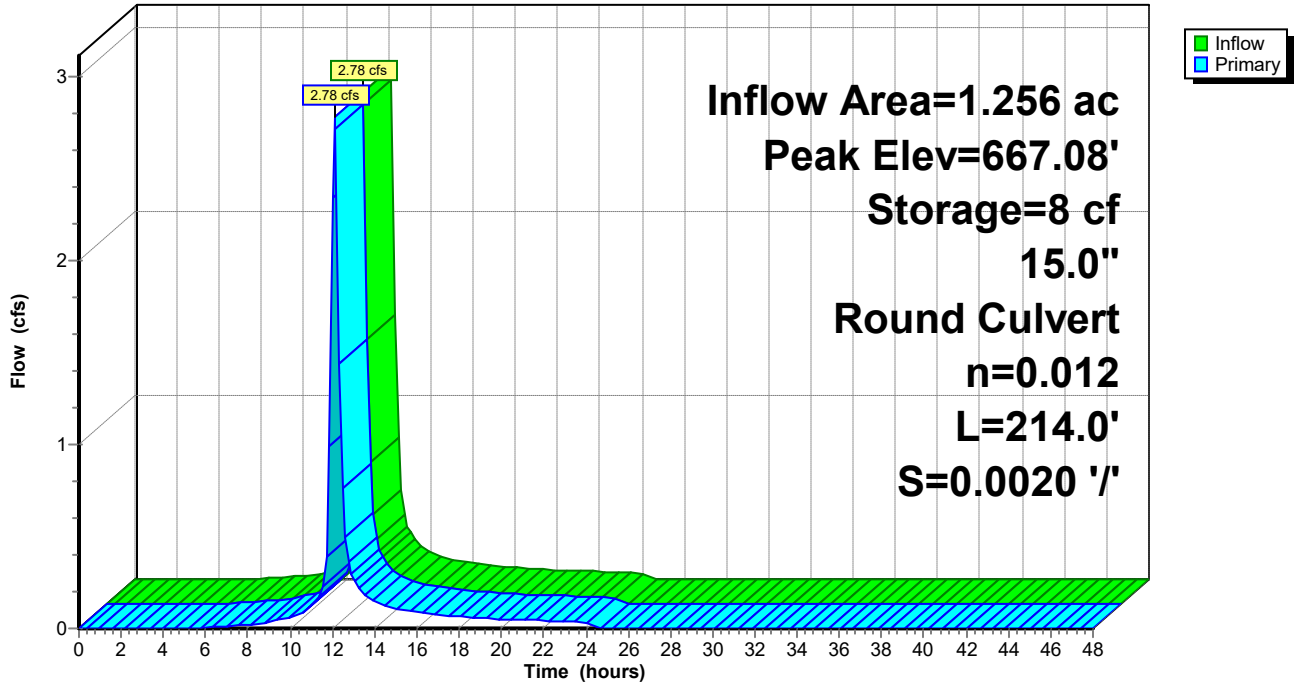

Plug Power - Proposed Conditions 5-15-21

Type II 24-hr 10-yr Rainfall=3.04"

Prepared by {enter your company name here}

Printed 5/20/2021

HydroCAD® 10.10-5a s/n 11585 © 2020 HydroCAD Software Solutions LLC

Page 150

Summary for Pond 39P: CB#30

Inflow Area = 2.166 ac, 42.53% Impervious, Inflow Depth = 1.83" for 10-yr event
 Inflow = 4.16 cfs @ 12.12 hrs, Volume= 0.330 af
 Outflow = 4.16 cfs @ 12.12 hrs, Volume= 0.330 af, Atten= 0%, Lag= 0.0 min
 Primary = 4.16 cfs @ 12.12 hrs, Volume= 0.330 af

Routing by Dyn-Stor-Ind method, Time Span= 0.00-48.00 hrs, dt= 0.15 hrs
 Peak Elev= 667.07' @ 12.48 hrs Surf.Area= 4 sf Storage= 10 cf
 Flood Elev= 668.00' Surf.Area= 220 sf Storage= 19 cf

Plug-Flow detention time= 0.1 min calculated for 0.329 af (100% of inflow)
 Center-of-Mass det. time= 0.1 min (824.1 - 824.0)

Volume	Invert	Avail.Storage	Storage Description
#1	664.64'	19 cf	Custom Stage Data (Prismatic) Listed below (Recalc)
Elevation (feet)	Surf.Area (sq-ft)	Inc.Store (cubic-feet)	Cum.Store (cubic-feet)
664.64	4	0	0
667.95	4	13	13
668.00	220	6	19

Device	Routing	Invert	Outlet Devices
#1	Primary	664.64'	18.0" Round Culvert L= 150.0' CPP, square edge headwall, Ke= 0.500 Inlet / Outlet Invert= 664.64' / 664.34' S= 0.0020 '/' Cc= 0.900 n= 0.012, Flow Area= 1.77 sf

Primary OutFlow Max=0.00 cfs @ 12.12 hrs HW=666.14' TW=666.46' (Dynamic Tailwater)
 ↑1=Culvert (Controls 0.00 cfs)

Pond 39P: CB#30

Hydrograph

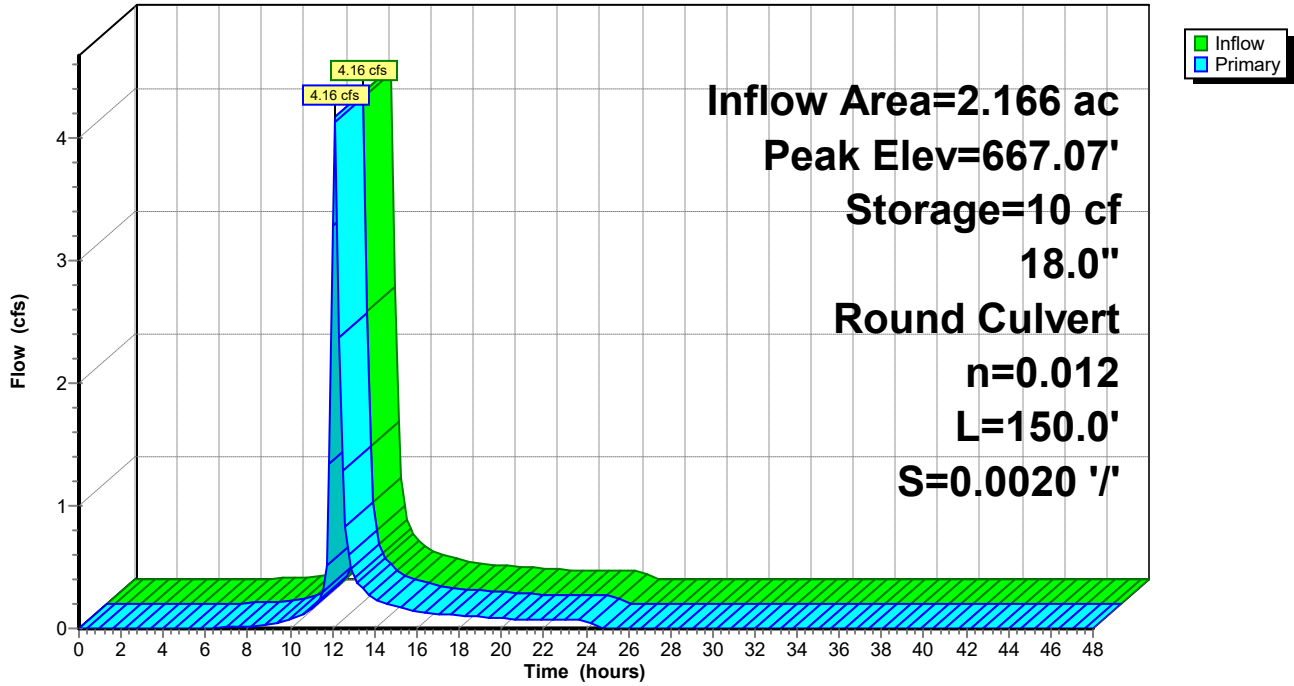

Plug Power - Proposed Conditions 5-15-21

Type II 24-hr 10-yr Rainfall=3.04"

Prepared by {enter your company name here}

Printed 5/20/2021

HydroCAD® 10.10-5a s/n 11585 © 2020 HydroCAD Software Solutions LLC

Page 152

Summary for Pond 41P: CB#32

Inflow Area = 2.889 ac, 56.91% Impervious, Inflow Depth = 2.07" for 10-yr event
Inflow = 6.01 cfs @ 12.13 hrs, Volume= 0.499 af
Outflow = 6.01 cfs @ 12.13 hrs, Volume= 0.499 af, Atten= 0%, Lag= 0.0 min
Primary = 6.01 cfs @ 12.13 hrs, Volume= 0.499 af

Routing by Dyn-Stor-Ind method, Time Span= 0.00-48.00 hrs, dt= 0.15 hrs
Peak Elev= 667.04' @ 12.34 hrs Surf.Area= 4 sf Storage= 11 cf
Flood Elev= 668.00' Surf.Area= 5 sf Storage= 15 cf

Plug-Flow detention time= 0.1 min calculated for 0.498 af (100% of inflow)
Center-of-Mass det. time= 0.1 min (805.4 - 805.3)

Volume	Invert	Avail.Storage	Storage Description
#1	664.34'	3,522 cf	Custom Stage Data (Prismatic) Listed below (Recalc)

Elevation (feet)	Surf.Area (sq-ft)	Inc.Store (cubic-feet)	Cum.Store (cubic-feet)
664.34	4	0	0
667.95	4	14	14
688.05	345	3,507	3,522

Device	Routing	Invert	Outlet Devices
#1	Primary	664.34'	24.0" Round Culvert L= 166.0' CPP, square edge headwall, Ke= 0.500 Inlet / Outlet Invert= 664.34' / 664.01' S= 0.0020 '/' Cc= 0.900 n= 0.012, Flow Area= 3.14 sf

Primary OutFlow Max=0.00 cfs @ 12.13 hrs HW=666.50' TW=666.88' (Dynamic Tailwater)
↑1=Culvert (Controls 0.00 cfs)

Pond 41P: CB#32

Hydrograph

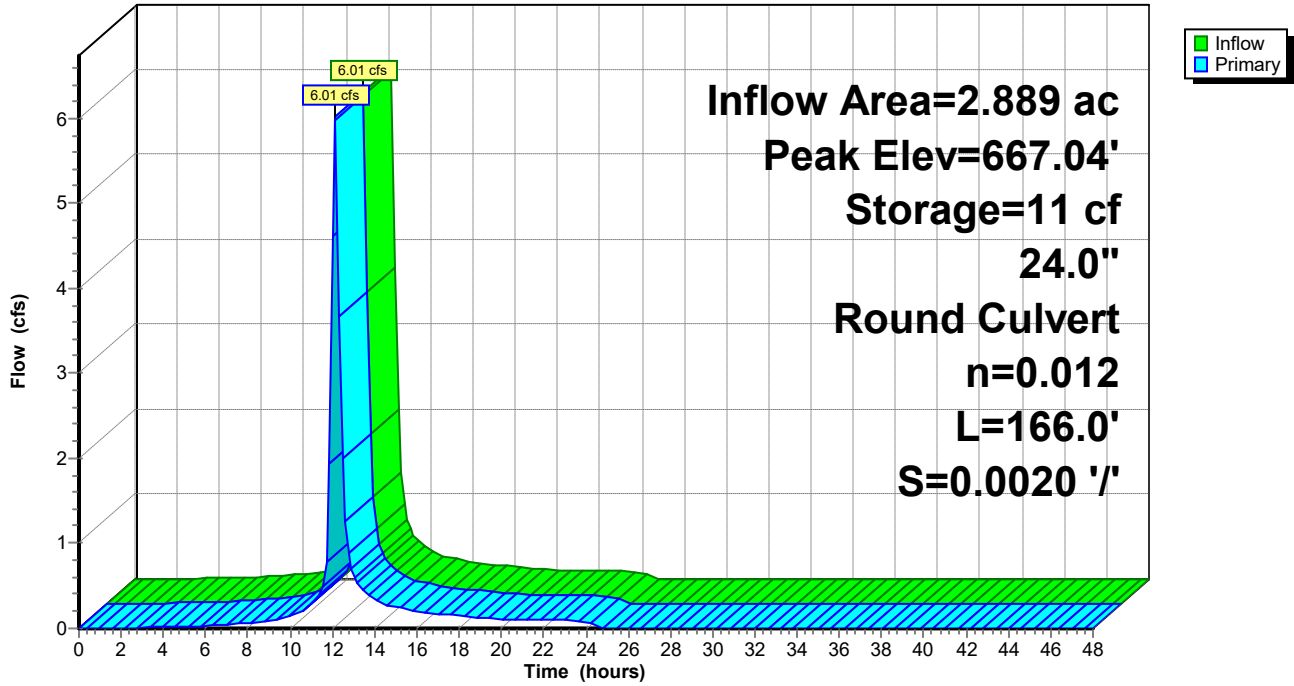

Plug Power - Proposed Conditions 5-15-21

Type II 24-hr 10-yr Rainfall=3.04"

Prepared by {enter your company name here}

Printed 5/20/2021

HydroCAD® 10.10-5a s/n 11585 © 2020 HydroCAD Software Solutions LLC

Page 154

Summary for Pond 44P: CB#24

Inflow Area = 4.895 ac, 67.05% Impervious, Inflow Depth = 2.21" for 10-yr event
Inflow = 10.87 cfs @ 12.00 hrs, Volume= 0.903 af
Outflow = 10.87 cfs @ 12.00 hrs, Volume= 0.903 af, Atten= 0%, Lag= 0.0 min
Primary = 10.87 cfs @ 12.00 hrs, Volume= 0.903 af

Routing by Dyn-Stor-Ind method, Time Span= 0.00-48.00 hrs, dt= 0.15 hrs

Peak Elev= 667.09' @ 12.00 hrs

Flood Elev= 669.85'

Device	Routing	Invert	Outlet Devices
#1	Primary	665.12'	24.0" Round Culvert L= 105.0' CPP, square edge headwall, Ke= 0.500 Inlet / Outlet Invert= 665.12' / 664.91' S= 0.0020 '/' Cc= 0.900 n= 0.012, Flow Area= 3.14 sf

Primary OutFlow Max=10.75 cfs @ 12.00 hrs HW=667.08' TW=666.38' (Dynamic Tailwater)
↑1=Culvert (Outlet Controls 10.75 cfs @ 4.35 fps)

Pond 44P: CB#24

Hydrograph

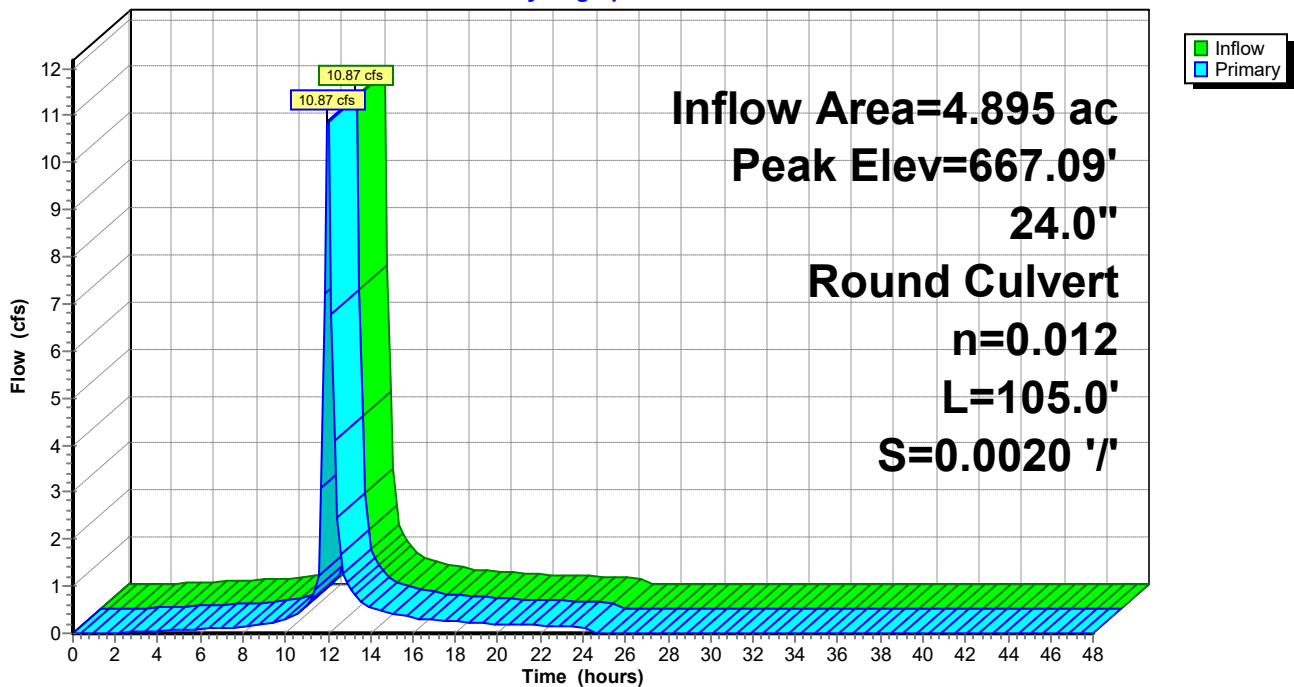

Plug Power - Proposed Conditions 5-15-21

Type II 24-hr 10-yr Rainfall=3.04"

Prepared by {enter your company name here}

Printed 5/20/2021

HydroCAD® 10.10-5a s/n 11585 © 2020 HydroCAD Software Solutions LLC

Page 155

Summary for Pond 46P: CB#20

Inflow Area = 3.433 ac, 66.17% Impervious, Inflow Depth = 2.21" for 10-yr event
Inflow = 7.61 cfs @ 12.01 hrs, Volume= 0.633 af
Outflow = 7.61 cfs @ 12.01 hrs, Volume= 0.633 af, Atten= 0%, Lag= 0.0 min
Primary = 7.61 cfs @ 12.01 hrs, Volume= 0.633 af

Routing by Dyn-Stor-Ind method, Time Span= 0.00-48.00 hrs, dt= 0.15 hrs

Peak Elev= 667.33' @ 12.11 hrs

Flood Elev= 669.85'

Device	Routing	Invert	Outlet Devices
#1	Primary	665.43'	24.0" Round Culvert L= 157.0' CPP, square edge headwall, Ke= 0.500 Inlet / Outlet Invert= 665.43' / 665.12' S= 0.0020 '/ Cc= 0.900 n= 0.012, Flow Area= 3.14 sf

Primary OutFlow Max=3.56 cfs @ 12.01 hrs HW=667.19' TW=667.07' (Dynamic Tailwater)
↑1=Culvert (Outlet Controls 3.56 cfs @ 1.62 fps)

Pond 46P: CB#20

Hydrograph

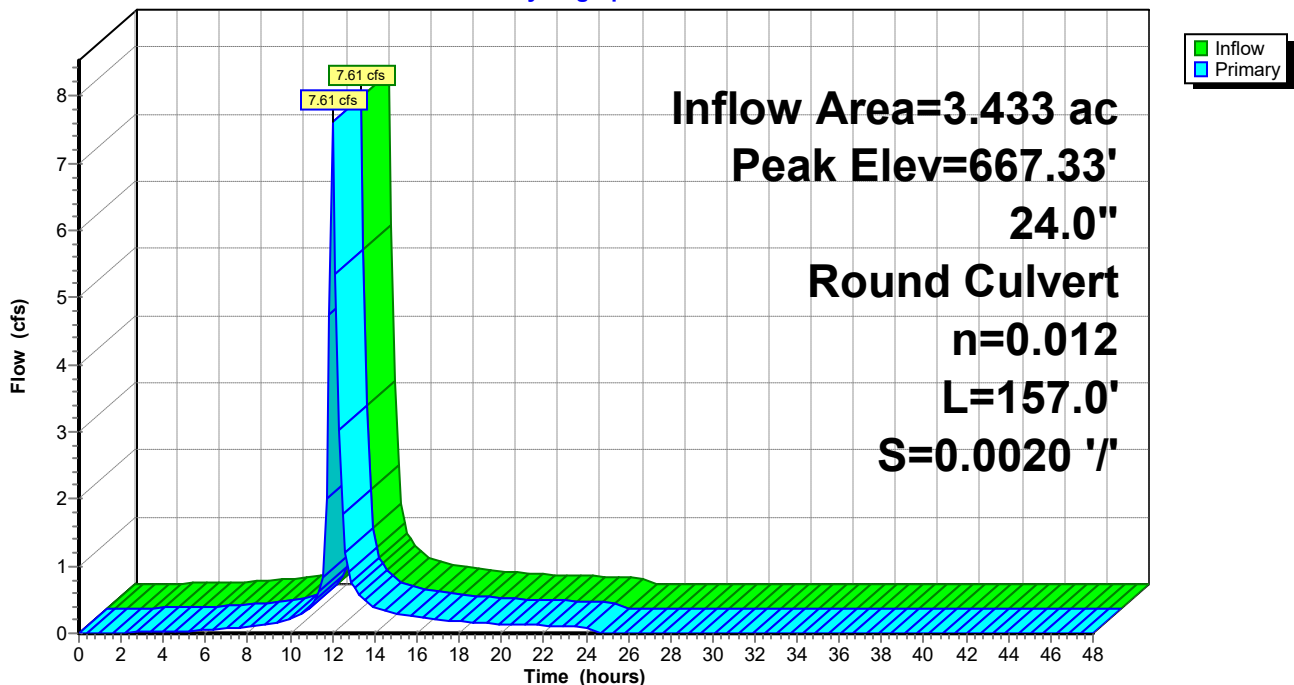

Plug Power - Proposed Conditions 5-15-21

Type II 24-hr 10-yr Rainfall=3.04"

Prepared by {enter your company name here}

Printed 5/20/2021

HydroCAD® 10.10-5a s/n 11585 © 2020 HydroCAD Software Solutions LLC

Page 156

Summary for Pond 50P: YD#8

Inflow Area = 2.660 ac, 32.37% Impervious, Inflow Depth = 1.67" for 10-yr event
 Inflow = 4.19 cfs @ 12.19 hrs, Volume= 0.369 af
 Outflow = 4.19 cfs @ 12.19 hrs, Volume= 0.369 af, Atten= 0%, Lag= 0.0 min
 Primary = 4.19 cfs @ 12.19 hrs, Volume= 0.369 af

Routing by Dyn-Stor-Ind method, Time Span= 0.00-48.00 hrs, dt= 0.15 hrs
 Peak Elev= 668.45' @ 12.25 hrs Surf.Area= 1 sf Storage= 1 cf
 Flood Elev= 669.90' Surf.Area= 8,385 sf Storage= 3,357 cf

Plug-Flow detention time= 0.0 min calculated for 0.368 af (100% of inflow)
 Center-of-Mass det. time= 0.0 min (840.4 - 840.4)

Volume	Invert	Avail.Storage	Storage Description
#1	666.95'	3,357 cf	Custom Stage Data (Prismatic) Listed below (Recalc)
Elevation (feet)	Surf.Area (sq-ft)	Inc.Store (cubic-feet)	Cum.Store (cubic-feet)
666.95	1	0	0
669.10	1	2	2
669.90	8,385	3,354	3,357

Device	Routing	Invert	Outlet Devices
#1	Primary	666.95'	18.0" Round Culvert L= 122.0' CPP, square edge headwall, Ke= 0.500 Inlet / Outlet Invert= 666.95' / 666.71' S= 0.0020 '/' Cc= 0.900 n= 0.012, Flow Area= 1.77 sf

Primary OutFlow Max=3.54 cfs @ 12.19 hrs HW=668.39' TW=668.07' (Dynamic Tailwater)
 ↑**1=Culvert** (Outlet Controls 3.54 cfs @ 2.61 fps)

Pond 50P: YD#8

Hydrograph

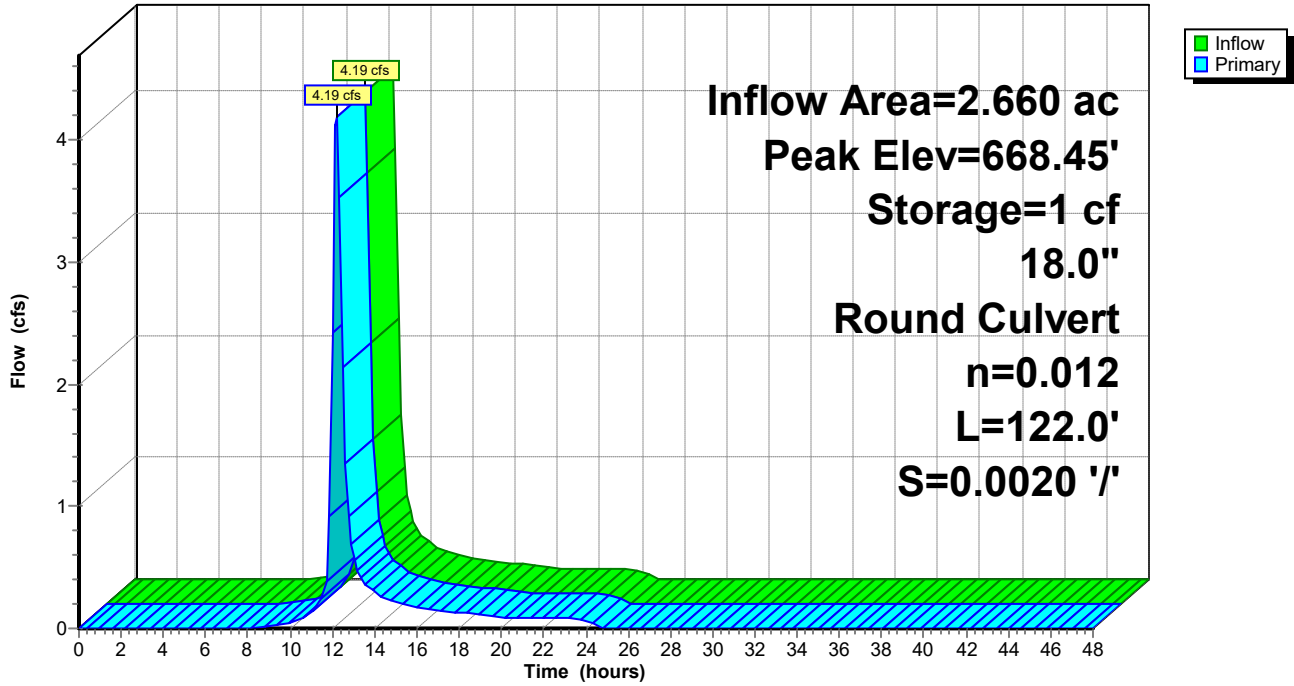

Plug Power - Proposed Conditions 5-15-21

Type II 24-hr 10-yr Rainfall=3.04"

Prepared by {enter your company name here}

Printed 5/20/2021

HydroCAD® 10.10-5a s/n 11585 © 2020 HydroCAD Software Solutions LLC

Page 158

Summary for Pond 51P: YD#6

Inflow Area = 1.879 ac, 30.11% Impervious, Inflow Depth = 1.62" for 10-yr event
Inflow = 2.84 cfs @ 12.19 hrs, Volume= 0.254 af
Outflow = 2.84 cfs @ 12.19 hrs, Volume= 0.254 af, Atten= 0%, Lag= 0.0 min
Primary = 2.84 cfs @ 12.19 hrs, Volume= 0.254 af

Routing by Dyn-Stor-Ind method, Time Span= 0.00-48.00 hrs, dt= 0.15 hrs
Peak Elev= 668.65' @ 12.33 hrs Surf.Area= 1 sf Storage= 1 cf
Flood Elev= 669.70' Surf.Area= 7,065 sf Storage= 1,592 cf

Plug-Flow detention time= 0.0 min calculated for 0.253 af (100% of inflow)
Center-of-Mass det. time= 0.0 min (843.2 - 843.2)

Volume	Invert	Avail.Storage	Storage Description
#1	667.23'	1,592 cf	Custom Stage Data (Prismatic) Listed below (Recalc)

Elevation (feet)	Surf.Area (sq-ft)	Inc.Store (cubic-feet)	Cum.Store (cubic-feet)
667.23	1	0	0
669.25	1	2	2
669.70	7,065	1,590	1,592

Device	Routing	Invert	Outlet Devices
#1	Primary	667.23'	15.0" Round Culvert L= 138.0' CPP, square edge headwall, Ke= 0.500 Inlet / Outlet Invert= 667.23' / 666.95' S= 0.0020 '/' Cc= 0.900 n= 0.012, Flow Area= 1.23 sf

Primary OutFlow Max=1.31 cfs @ 12.19 hrs HW=668.49' TW=668.39' (Dynamic Tailwater)
↑**1=Culvert** (Outlet Controls 1.31 cfs @ 1.32 fps)

Pond 51P: YD#6

Hydrograph

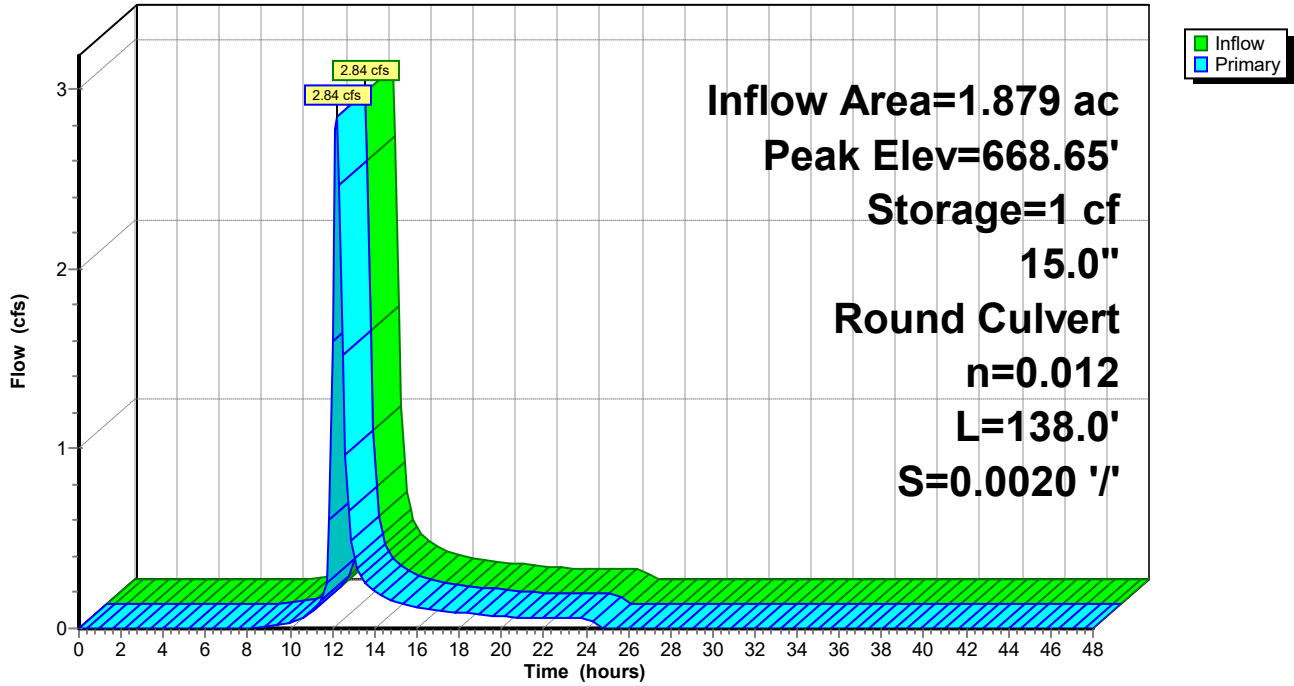

Summary for Link 52L: Total Site Discharge

Inflow Area = 29.096 ac, 42.99% Impervious, Inflow Depth = 1.84" for 10-yr event
Inflow = 13.50 cfs @ 12.96 hrs, Volume= 4.464 af
Primary = 13.50 cfs @ 12.96 hrs, Volume= 4.464 af, Atten= 0%, Lag= 0.0 min

Primary outflow = Inflow, Time Span= 0.00-48.00 hrs, dt= 0.15 hrs

Link 52L: Total Site Discharge

Hydrograph

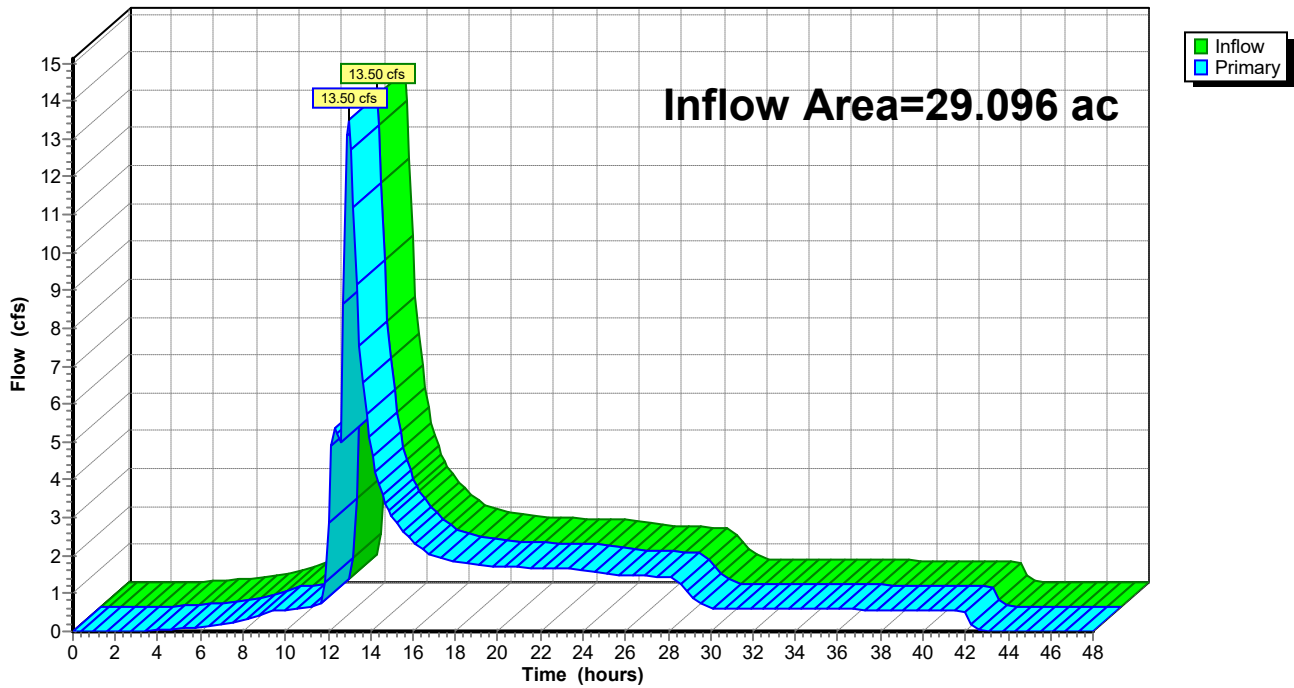

Plug Power - Proposed Conditions 5-15-21

Type II 24-hr 25-yr Rainfall=3.71"

Prepared by {enter your company name here}

Printed 5/20/2021

HydroCAD® 10.10-5a s/n 11585 © 2020 HydroCAD Software Solutions LLC

Page 161

Time span=0.00-48.00 hrs, dt=0.15 hrs, 321 points
 Runoff by SCS TR-20 method, UH=SCS, Weighted-CN
 Reach routing by Dyn-Stor-Ind method - Pond routing by Dyn-Stor-Ind method

Subcatchment 1S: Prop. Area to SW	Runoff Area=25,495 sf	0.00% Impervious	Runoff Depth=1.73"
	Flow Length=90'	Slope=0.0200 '/'	Tc=20.5 min CN=79 Runoff=1.06 cfs 0.084 af
Subcatchment 2S: Prop. Area to SE	Runoff Area=12,470 sf	0.00% Impervious	Runoff Depth=1.73"
	Flow Length=100'	Slope=0.0150 '/'	Tc=19.6 min CN=79 Runoff=0.53 cfs 0.041 af
Subcatchment 3S: Prop. Area to West	Runoff Area=38,190 sf	0.00% Impervious	Runoff Depth=1.73"
	Flow Length=350'	Tc=18.2 min	CN=79 Runoff=1.64 cfs 0.126 af
Subcatchment 4S: Prop. Area to Crosby	Runoff Area=10,015 sf	0.00% Impervious	Runoff Depth=1.73"
	Flow Length=125'	Slope=0.0100 '/'	Tc=23.3 min CN=79 Runoff=0.39 cfs 0.033 af
Subcatchment 8S: Area Overland to North	Runoff Area=51,085 sf	0.00% Impervious	Runoff Depth=1.59"
	Flow Length=140'	Tc=11.7 min	CN=77 Runoff=2.36 cfs 0.155 af
Subcatchment 10S: Area to CB#1	Runoff Area=19,240 sf	67.06% Impervious	Runoff Depth=2.84"
	Flow Length=80'	Tc=12.8 min	CN=92 Runoff=1.50 cfs 0.104 af
Subcatchment 12S: Area to CB#2	Runoff Area=12,315 sf	47.61% Impervious	Runoff Depth=2.55"
	Flow Length=80'	Tc=12.8 min	CN=89 Runoff=0.88 cfs 0.060 af
Subcatchment 14S: Area to CB#3	Runoff Area=18,345 sf	46.99% Impervious	Runoff Depth=2.46"
	Flow Length=260'	Tc=19.1 min	CN=88 Runoff=1.10 cfs 0.086 af
Subcatchment 18S: Area to YD#2	Runoff Area=27,200 sf	27.67% Impervious	Runoff Depth=1.96"
	Flow Length=140'	Slope=0.0100 '/'	Tc=23.4 min UI Adjusted CN=82 Runoff=1.20 cfs 0.102 af
Subcatchment 20S: Eastern Area	Runoff Area=329,310 sf	62.48% Impervious	Runoff Depth=2.74"
	Flow Length=330'	Tc=30.2 min	CN=91 Runoff=16.96 cfs 1.726 af
Subcatchment 24S: Area to YD#11	Runoff Area=38,900 sf	53.89% Impervious	Runoff Depth=2.65"
	Flow Length=70'	Slope=0.0100 '/'	Tc=17.3 min CN=90 Runoff=2.53 cfs 0.197 af
Subcatchment 26S: Area to CB#4	Runoff Area=41,205 sf	62.20% Impervious	Runoff Depth=2.74"
	Flow Length=100'	Tc=16.9 min	CN=91 Runoff=2.76 cfs 0.216 af
Subcatchment 29S: Area to CB#15	Runoff Area=17,040 sf	100.00% Impervious	Runoff Depth=3.48"
		Tc=5.0 min	CN=98 Runoff=1.66 cfs 0.113 af
Subcatchment 30S: Area to CB#18	Runoff Area=20,100 sf	15.05% Impervious	Runoff Depth=1.88"
	Flow Length=140'	Slope=0.0100 '/'	Tc=23.4 min UI Adjusted CN=81 Runoff=0.85 cfs 0.072 af
Subcatchment 32S: Area to CB#7	Runoff Area=36,220 sf	69.35% Impervious	Runoff Depth=2.84"
	Flow Length=100'	Tc=16.9 min	CN=92 Runoff=2.49 cfs 0.197 af
Subcatchment 36S: Area to CB#9	Runoff Area=18,475 sf	44.79% Impervious	Runoff Depth=2.46"
	Flow Length=80'	Slope=0.0100 '/'	Tc=19.3 min CN=88 Runoff=1.11 cfs 0.087 af

Plug Power - Proposed Conditions 5-15-21

Type II 24-hr 25-yr Rainfall=3.71"

Prepared by {enter your company name here}

Printed 5/20/2021

HydroCAD® 10.10-5a s/n 11585 © 2020 HydroCAD Software Solutions LLC

Page 162

Subcatchment 38S: Area to CB#10	Runoff Area=39,650 sf 16.97% Impervious Runoff Depth=2.04"
Flow Length=150'	Slope=0.0140 '/' Tc=20.6 min CN=83 Runoff=1.94 cfs 0.154 af
Subcatchment 40S: Area to CB#11	Runoff Area=31,495 sf 100.00% Impervious Runoff Depth=3.48"
Flow Length=170'	Slope=0.0120 '/' Tc=22.1 min CN=98 Runoff=2.28 cfs 0.209 af
Subcatchment 42S: Western Area	Runoff Area=139,665 sf 42.71% Impervious Runoff Depth=2.46"
Flow Length=50'	Slope=0.0200 '/' Tc=6.3 min CN=88 Runoff=11.38 cfs 0.658 af
Subcatchment 43S: North Half of Phase 2	Runoff Area=36,505 sf 100.00% Impervious Runoff Depth=3.48"
	Tc=5.0 min CN=98 Runoff=3.56 cfs 0.243 af
Subcatchment 45S: South Half of Phase	Runoff Area=32,290 sf 100.00% Impervious Runoff Depth=3.48"
	Tc=5.0 min CN=98 Runoff=3.15 cfs 0.215 af
Subcatchment 48S: Area to YD#1	Runoff Area=34,030 sf 37.80% Impervious Runoff Depth=2.37"
Flow Length=150'	Slope=0.0100 '/' Tc=23.6 min CN=87 Runoff=1.81 cfs 0.154 af
Subcatchment 49S: Area to YD#3	Runoff Area=81,835 sf 30.11% Impervious Runoff Depth=2.20"
Flow Length=340'	Tc=25.3 min CN=85 Runoff=3.87 cfs 0.344 af
Subcatchment 52S: Area Overland to	Runoff Area=71,325 sf 0.00% Impervious Runoff Depth=1.80"
Flow Length=30'	Tc=5.4 min CN=80 Runoff=4.33 cfs 0.246 af
Subcatchment 53S: Area Overland to	Runoff Area=5,925 sf 0.00% Impervious Runoff Depth=1.80"
	Tc=5.0 min CN=80 Runoff=0.36 cfs 0.020 af
Subcatchment 54S: Area Overland to	Runoff Area=6,040 sf 0.00% Impervious Runoff Depth=1.80"
	Tc=5.0 min CN=80 Runoff=0.36 cfs 0.021 af
Subcatchment 55S: Area Overland to	Runoff Area=13,210 sf 0.00% Impervious Runoff Depth=1.80"
Flow Length=25'	Slope=0.0100 '/' Tc=7.6 min CN=80 Runoff=0.81 cfs 0.046 af
Subcatchment 56S: Area Overland to Dry	Runoff Area=19,245 sf 0.00% Impervious Runoff Depth=1.80"
	Tc=5.0 min CN=80 Runoff=1.16 cfs 0.066 af
Subcatchment 57S: Area Overland to North	Runoff Area=23,585 sf 0.00% Impervious Runoff Depth=1.59"
Flow Length=100'	Tc=10.8 min CN=77 Runoff=1.14 cfs 0.072 af
Subcatchment 58S: Area Overland to North	Runoff Area=17,005 sf 0.00% Impervious Runoff Depth=1.59"
Flow Length=170'	Tc=14.9 min CN=77 Runoff=0.68 cfs 0.052 af
Reach 7R: Crosby Road Ditch	Avg. Flow Depth=0.13' Max Vel=1.05 fps Inflow=0.39 cfs 0.033 af
n=0.030 L=450.0' S=0.0089 '/'	Capacity=98.41 cfs Outflow=0.34 cfs 0.033 af
Reach 9R: North Property Line Ditch	Avg. Flow Depth=0.28' Max Vel=1.56 fps Inflow=2.51 cfs 0.188 af
n=0.030 L=670.0' S=0.0100 '/'	Capacity=634.40 cfs Outflow=2.11 cfs 0.188 af
Reach 23R: North Swale to	Avg. Flow Depth=2.14' Max Vel=0.40 fps Inflow=11.25 cfs 1.863 af
n=0.300 L=180.0' S=0.0050 '/'	Capacity=23.67 cfs Outflow=10.83 cfs 1.863 af

Plug Power - Proposed Conditions 5-15-21

Type II 24-hr 25-yr Rainfall=3.71"

Prepared by {enter your company name here}

Printed 5/20/2021

HydroCAD® 10.10-5a s/n 11585 © 2020 HydroCAD Software Solutions LLC

Page 163

Reach 25R: North Property Line Ditch Avg. Flow Depth=0.49' Max Vel=1.36 fps Inflow=4.88 cfs 0.932 af
n=0.030 L=500.0' S=0.0040 '/' Capacity=401.23 cfs Outflow=4.65 cfs 0.932 af

Reach 26R: North Property Line Ditch Avg. Flow Depth=0.98' Max Vel=1.60 fps Inflow=18.61 cfs 5.652 af
n=0.030 L=500.0' S=0.0024 '/' Capacity=310.79 cfs Outflow=18.60 cfs 5.652 af

Reach 27R: Swale to Dry Pond Avg. Flow Depth=0.84' Max Vel=2.25 fps Inflow=17.15 cfs 0.606 af
x 2.00 n=0.030 L=130.0' S=0.0050 '/' Capacity=118.87 cfs Outflow=17.14 cfs 0.606 af

Reach 52R: West Swale to Avg. Flow Depth=2.66' Max Vel=0.46 fps Inflow=18.52 cfs 2.558 af
n=0.300 L=180.0' S=0.0050 '/' Capacity=23.67 cfs Outflow=17.84 cfs 2.558 af

Pond 11P: CB#1 Peak Elev=668.89' Inflow=1.50 cfs 0.104 af
12.0" Round Culvert n=0.012 L=137.0' S=0.0020 '/' Outflow=1.50 cfs 0.104 af

Pond 13P: CB#3 Peak Elev=668.81' Inflow=2.37 cfs 0.165 af
12.0" Round Culvert n=0.012 L=213.0' S=0.0020 '/' Outflow=2.37 cfs 0.165 af

Pond 15P: CB#5 Peak Elev=668.39' Inflow=8.42 cfs 0.750 af
24.0" Round Culvert n=0.012 L=180.0' S=0.0020 '/' Outflow=8.42 cfs 0.750 af

Pond 19P: YD#22 Peak Elev=667.80' Storage=3 cf Inflow=1.20 cfs 0.102 af
10.0" Round Culvert n=0.012 L=70.0' S=0.0020 '/' Outflow=1.20 cfs 0.102 af

Pond 21P: Subsurface Detention within Peak Elev=667.49' Storage=10,573 cf Inflow=48.11 cfs 4.939 af
Primary=18.36 cfs 2.537 af Secondary=11.11 cfs 1.842 af Tertiary=16.93 cfs 0.560 af Outflow=45.73 cfs 4.939 af

Pond 22P: Bio-Retention Area Peak Elev=664.44' Storage=77,167 cf Inflow=29.47 cfs 4.667 af
Primary=14.75 cfs 4.669 af Secondary=0.00 cfs 0.000 af Outflow=14.75 cfs 4.669 af

Pond 25P: YD#11 Peak Elev=668.61' Storage=2 cf Inflow=2.53 cfs 0.197 af
12.0" Round Culvert n=0.012 L=170.0' S=0.0020 '/' Outflow=2.52 cfs 0.197 af

Pond 27P: CB#4 Peak Elev=668.23' Storage=9 cf Inflow=2.76 cfs 0.216 af
12.0" Round Culvert n=0.012 L=40.0' S=0.0020 '/' Outflow=2.75 cfs 0.216 af

Pond 28P: CB#15 Peak Elev=668.18' Storage=9 cf Inflow=6.34 cfs 0.526 af
18.0" Round Culvert n=0.012 L=157.0' S=0.0020 '/' Outflow=6.34 cfs 0.526 af

Pond 29P: Dry Pond Peak Elev=664.97' Storage=20,979 cf Inflow=17.30 cfs 0.672 af
Primary=3.14 cfs 0.672 af Tertiary=0.00 cfs 0.000 af Outflow=3.14 cfs 0.672 af

Pond 31P: CB#18 Peak Elev=668.07' Storage=10 cf Inflow=6.96 cfs 0.598 af
18.0" Round Culvert n=0.012 L=83.0' S=0.0020 '/' Outflow=6.95 cfs 0.599 af

Pond 33P: CB#26 Peak Elev=667.68' Storage=9 cf Inflow=2.49 cfs 0.197 af
12.0" Round Culvert n=0.012 L=175.0' S=0.0020 '/' Outflow=2.49 cfs 0.197 af

Pond 37P: CB#28 Peak Elev=667.67' Storage=10 cf Inflow=3.59 cfs 0.284 af
15.0" Round Culvert n=0.012 L=214.0' S=0.0020 '/' Outflow=3.58 cfs 0.284 af

Plug Power - Proposed Conditions 5-15-21

Type II 24-hr 25-yr Rainfall=3.71"

Prepared by {enter your company name here}

Printed 5/20/2021

HydroCAD® 10.10-5a s/n 11585 © 2020 HydroCAD Software Solutions LLC

Page 164

Pond 39P: CB#30 Peak Elev=667.64' Storage=12 cf Inflow=5.50 cfs 0.438 af
18.0" Round Culvert n=0.012 L=150.0' S=0.0020 '/ Outflow=5.49 cfs 0.438 af

Pond 41P: CB#32 Peak Elev=667.59' Storage=13 cf Inflow=7.76 cfs 0.648 af
24.0" Round Culvert n=0.012 L=166.0' S=0.0020 '/ Outflow=7.75 cfs 0.648 af

Pond 44P: CB#24 Peak Elev=667.60' Inflow=13.78 cfs 1.158 af
24.0" Round Culvert n=0.012 L=105.0' S=0.0020 '/ Outflow=13.78 cfs 1.158 af

Pond 46P: CB#20 Peak Elev=667.74' Inflow=9.69 cfs 0.813 af
24.0" Round Culvert n=0.012 L=157.0' S=0.0020 '/ Outflow=9.69 cfs 0.813 af

Pond 50P: YD#8 Peak Elev=668.80' Storage=2 cf Inflow=5.67 cfs 0.499 af
18.0" Round Culvert n=0.012 L=122.0' S=0.0020 '/ Outflow=5.67 cfs 0.499 af

Pond 51P: YD#6 Peak Elev=669.19' Storage=2 cf Inflow=3.87 cfs 0.344 af
15.0" Round Culvert n=0.012 L=138.0' S=0.0020 '/ Outflow=3.87 cfs 0.344 af

Link 52L: Total Site Discharge Inflow=19.06 cfs 5.905 af
Primary=19.06 cfs 5.905 af

Total Runoff Area = 29.096 ac Runoff Volume = 5.903 af Average Runoff Depth = 2.43"
57.01% Pervious = 16.587 ac 42.99% Impervious = 12.509 ac

Plug Power - Proposed Conditions 5-15-21

Type II 24-hr 25-yr Rainfall=3.71"

Prepared by {enter your company name here}

Printed 5/20/2021

HydroCAD® 10.10-5a s/n 11585 © 2020 HydroCAD Software Solutions LLC

Page 165

Summary for Subcatchment 1S: Prop. Area to SW Property Line (Wetland)

Runoff = 1.06 cfs @ 12.15 hrs, Volume= 0.084 af, Depth= 1.73"

Runoff by SCS TR-20 method, UH=SCS, Weighted-CN, Time Span= 0.00-48.00 hrs, dt= 0.15 hrs
Type II 24-hr 25-yr Rainfall=3.71"

Area (sf)	CN	Description
5,020	78	Meadow, non-grazed, HSG D
18,430	79	Woods, Fair, HSG D
2,045	80	>75% Grass cover, Good, HSG D
25,495	79	Weighted Average
25,495		100.00% Pervious Area

Tc (min)	Length (feet)	Slope (ft/ft)	Velocity (ft/sec)	Capacity (cfs)	Description
2.8	10	0.0200	0.06		Sheet Flow, 10' Overland Flow Grass: Dense n= 0.240 P2= 2.14"
5.1	40	0.0200	0.13		Sheet Flow, 40' Overland Flow Range n= 0.130 P2= 2.14"
12.6	40	0.0200	0.05		Sheet Flow, 40' Overland Flow Woods: Light underbrush n= 0.400 P2= 2.14"
20.5	90	Total			

Subcatchment 1S: Prop. Area to SW Property Line (Wetland)

Hydrograph

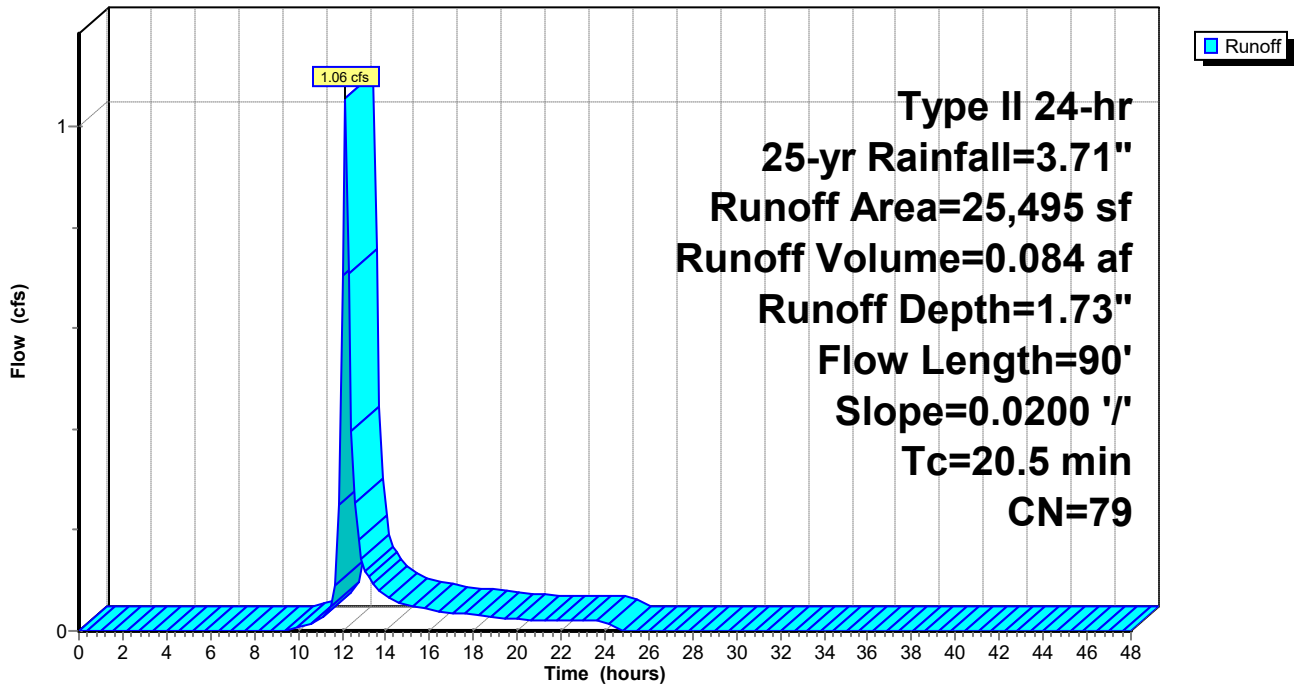

Plug Power - Proposed Conditions 5-15-21

Type II 24-hr 25-yr Rainfall=3.71"

Prepared by {enter your company name here}

Printed 5/20/2021

HydroCAD® 10.10-5a s/n 11585 © 2020 HydroCAD Software Solutions LLC

Page 166

Summary for Subcatchment 2S: Prop. Area to SE Property Line

Runoff = 0.53 cfs @ 12.14 hrs, Volume= 0.041 af, Depth= 1.73"

Runoff by SCS TR-20 method, UH=SCS, Weighted-CN, Time Span= 0.00-48.00 hrs, dt= 0.15 hrs
Type II 24-hr 25-yr Rainfall=3.71"

Area (sf)	CN	Description
12,470	79	Woods/grass comb., Good, HSG D
12,470		100.00% Pervious Area

Tc (min)	Length (feet)	Slope (ft/ft)	Velocity (ft/sec)	Capacity (cfs)	Description
19.6	100	0.0150	0.09		Sheet Flow, 100' Overland Flow Grass: Dense n= 0.240 P2= 2.14"

Subcatchment 2S: Prop. Area to SE Property Line

Hydrograph

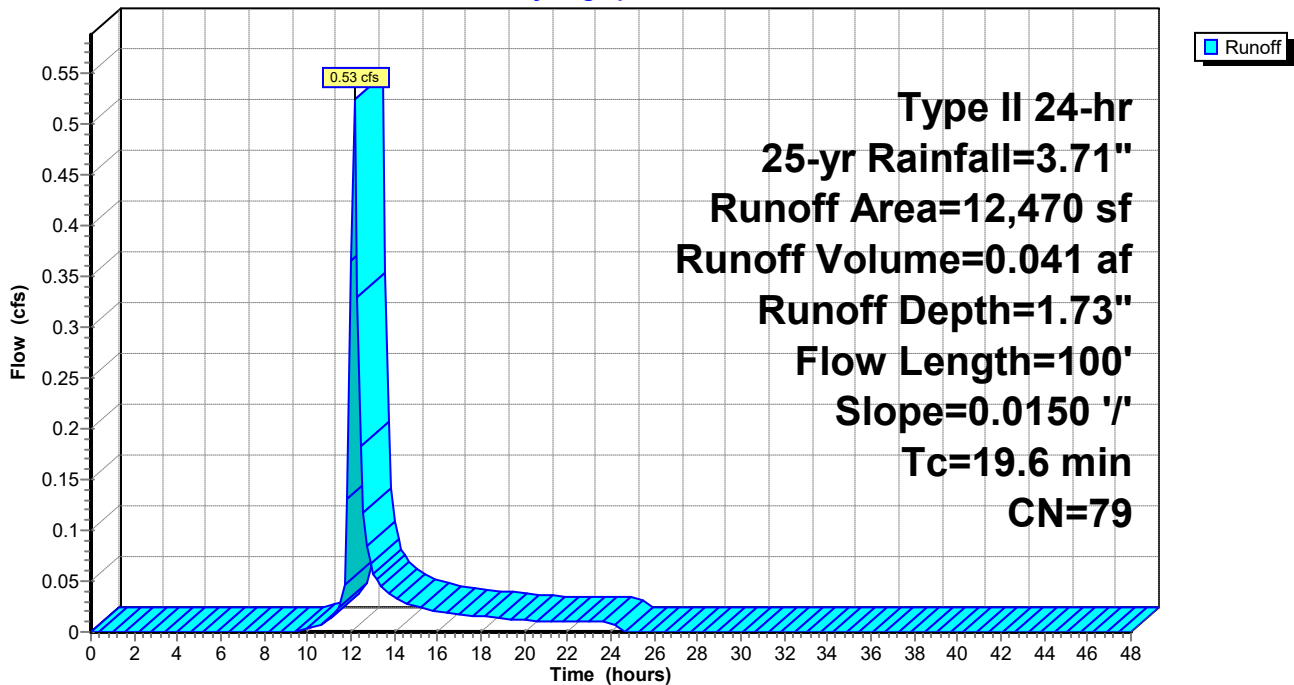

Plug Power - Proposed Conditions 5-15-21

Type II 24-hr 25-yr Rainfall=3.71"

Prepared by {enter your company name here}

Printed 5/20/2021

HydroCAD® 10.10-5a s/n 11585 © 2020 HydroCAD Software Solutions LLC

Page 167

Summary for Subcatchment 3S: Prop. Area to West Property Line (Wetland)

Runoff = 1.64 cfs @ 12.13 hrs, Volume= 0.126 af, Depth= 1.73"

Runoff by SCS TR-20 method, UH=SCS, Weighted-CN, Time Span= 0.00-48.00 hrs, dt= 0.15 hrs
 Type II 24-hr 25-yr Rainfall=3.71"

Area (sf)	CN	Description
20,080	80	>75% Grass cover, Good, HSG D
18,110	78	Meadow, non-grazed, HSG D
38,190	79	Weighted Average
38,190		100.00% Pervious Area

Tc (min)	Length (feet)	Slope (ft/ft)	Velocity (ft/sec)	Capacity (cfs)	Description
16.0	100	0.0250	0.10		Sheet Flow, 100' Overland Flow Grass: Dense n= 0.240 P2= 2.14"
2.2	250	0.0160	1.90		Shallow Concentrated Flow, 250' Shallow Conc. Flow Grassed Waterway Kv= 15.0 fps
18.2	350	Total			

Subcatchment 3S: Prop. Area to West Property Line (Wetland)

Hydrograph

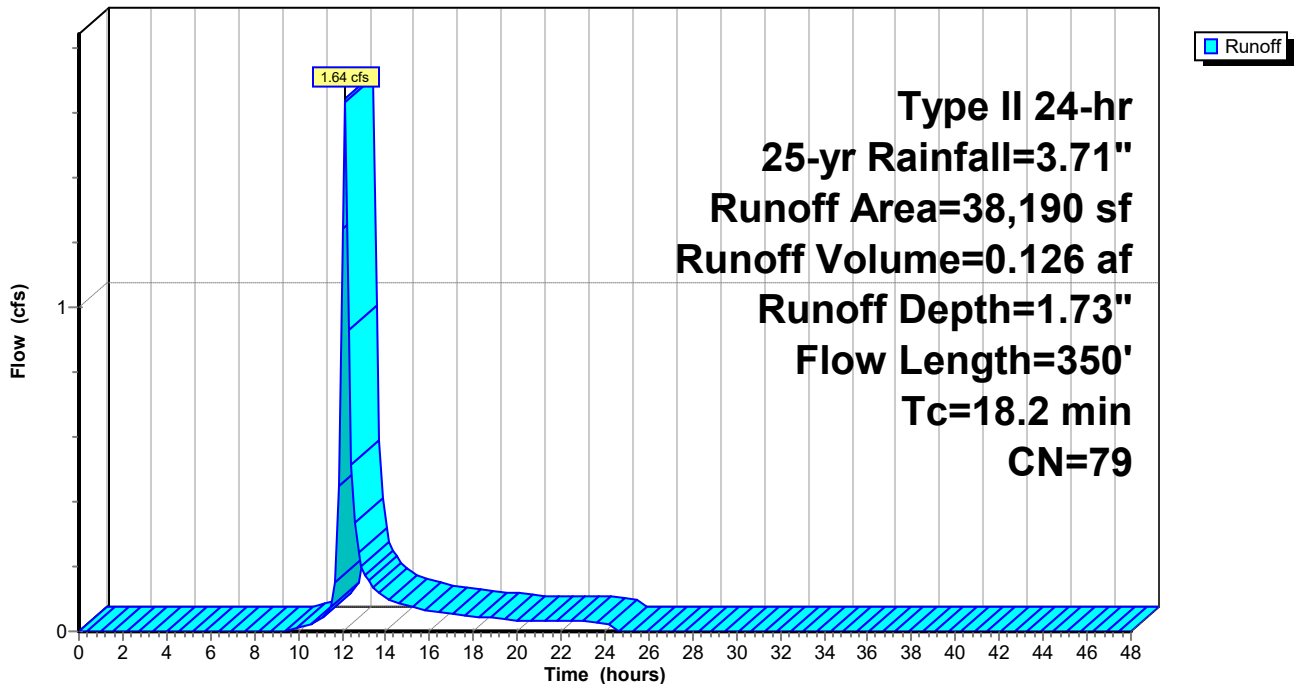

Plug Power - Proposed Conditions 5-15-21

Type II 24-hr 25-yr Rainfall=3.71"

Prepared by {enter your company name here}

Printed 5/20/2021

HydroCAD® 10.10-5a s/n 11585 © 2020 HydroCAD Software Solutions LLC

Page 168

Summary for Subcatchment 4S: Prop. Area to Crosby Road Ditch

Runoff = 0.39 cfs @ 12.18 hrs, Volume= 0.033 af, Depth= 1.73"

Runoff by SCS TR-20 method, UH=SCS, Weighted-CN, Time Span= 0.00-48.00 hrs, dt= 0.15 hrs
Type II 24-hr 25-yr Rainfall=3.71"

Area (sf)	CN	Description
10,015	79	Woods/grass comb., Good, HSG D
10,015		100.00% Pervious Area

Tc (min)	Length (feet)	Slope (ft/ft)	Velocity (ft/sec)	Capacity (cfs)	Description
23.0	100	0.0100	0.07		Sheet Flow, 100' Overland Flow Grass: Dense n= 0.240 P2= 2.14"
0.3	25	0.0100	1.50		Shallow Concentrated Flow, 25' Shallow Conc. Flow Grassed Waterway Kv= 15.0 fps
23.3	125	Total			

Subcatchment 4S: Prop. Area to Crosby Road Ditch

Hydrograph

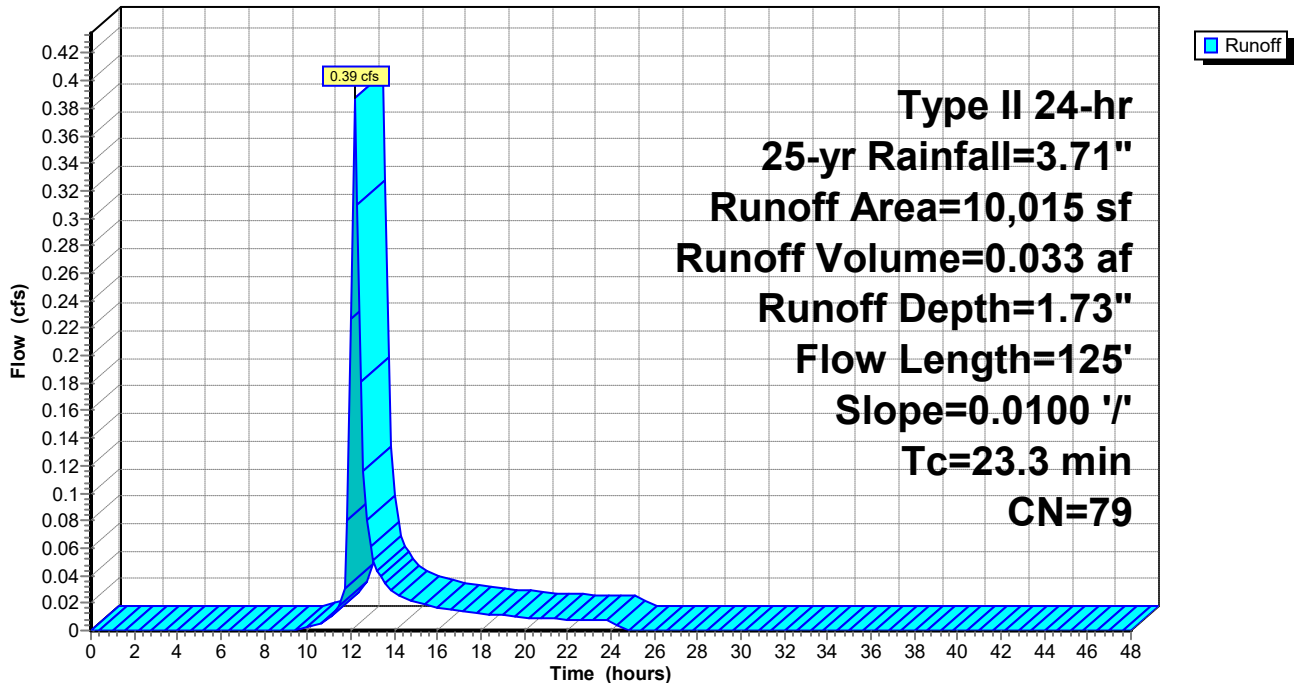

Plug Power - Proposed Conditions 5-15-21

Type II 24-hr 25-yr Rainfall=3.71"

Prepared by {enter your company name here}

Printed 5/20/2021

HydroCAD® 10.10-5a s/n 11585 © 2020 HydroCAD Software Solutions LLC

Page 169

Summary for Subcatchment 8S: Area Overland to North Prop. Line and Wetland Ditch (East)

Runoff = 2.36 cfs @ 12.03 hrs, Volume= 0.155 af, Depth= 1.59"

Runoff by SCS TR-20 method, UH=SCS, Weighted-CN, Time Span= 0.00-48.00 hrs, dt= 0.15 hrs
Type II 24-hr 25-yr Rainfall=3.71"

Area (sf)	CN	Description
51,085	77	Brush, Fair, HSG D
51,085		100.00% Pervious Area

Tc (min)	Length (feet)	Slope (ft/ft)	Velocity (ft/sec)	Capacity (cfs)	Description
10.7	100	0.0200	0.16		Sheet Flow, 100' Overland Flow Range n= 0.130 P2= 2.14"
1.0	40	0.0100	0.70		Shallow Concentrated Flow, 40' Shallow Conc. Flow Short Grass Pasture Kv= 7.0 fps
11.7	140	Total			

Subcatchment 8S: Area Overland to North Prop. Line and Wetland Ditch (East)

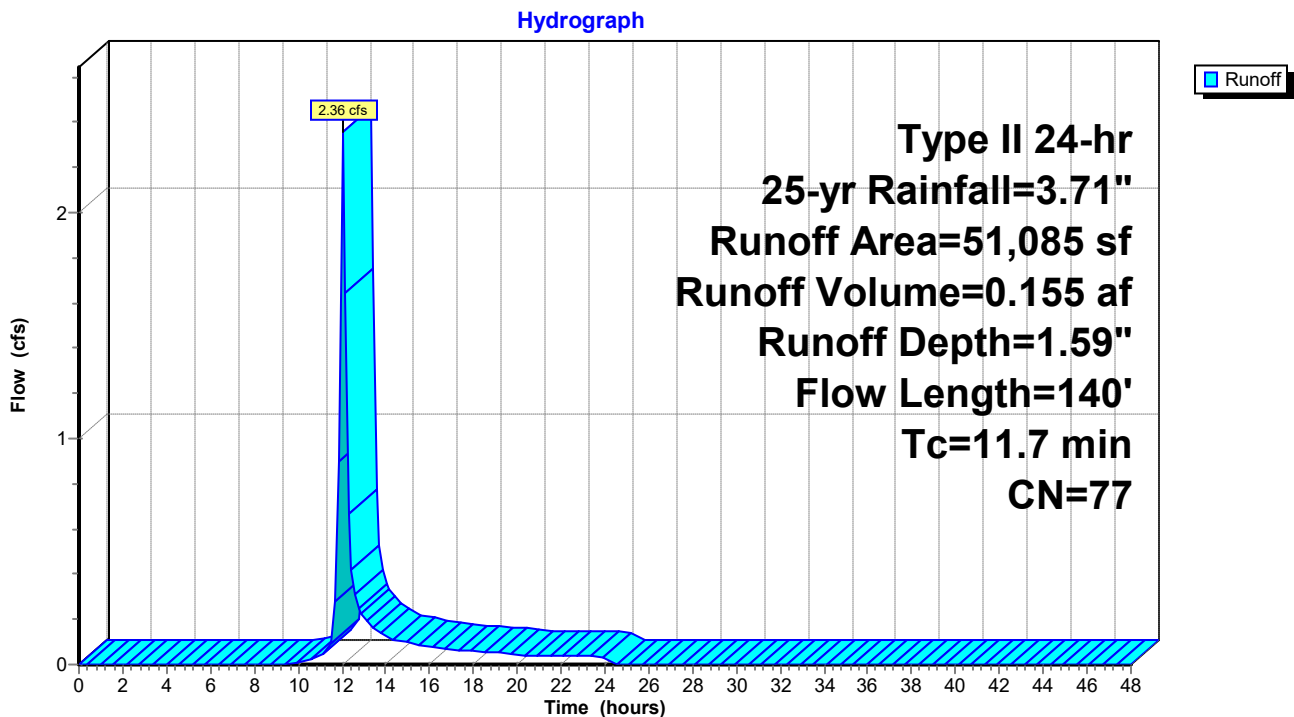

Plug Power - Proposed Conditions 5-15-21

Type II 24-hr 25-yr Rainfall=3.71"

Prepared by {enter your company name here}

Printed 5/20/2021

HydroCAD® 10.10-5a s/n 11585 © 2020 HydroCAD Software Solutions LLC

Page 170

Summary for Subcatchment 10S: Area to CB#1

Runoff = 1.50 cfs @ 12.02 hrs, Volume= 0.104 af, Depth= 2.84"

Runoff by SCS TR-20 method, UH=SCS, Weighted-CN, Time Span= 0.00-48.00 hrs, dt= 0.15 hrs
Type II 24-hr 25-yr Rainfall=3.71"

Area (sf)	CN	Description
4,063	98	Roofs, HSG D
8,840	98	Paved parking, HSG D
6,337	80	>75% Grass cover, Good, HSG D
19,240	92	Weighted Average
6,337		32.94% Pervious Area
12,903		67.06% Impervious Area

Tc (min)	Length (feet)	Slope (ft/ft)	Velocity (ft/sec)	Capacity (cfs)	Description
12.4	65	0.0200	0.09		Sheet Flow, 65' Overland Flow Grass: Dense n= 0.240 P2= 2.14"
0.4	15	0.0100	0.58		Sheet Flow, 15' Overland Flow Smooth surfaces n= 0.011 P2= 2.14"
12.8	80	Total			

Subcatchment 10S: Area to CB#1

Hydrograph

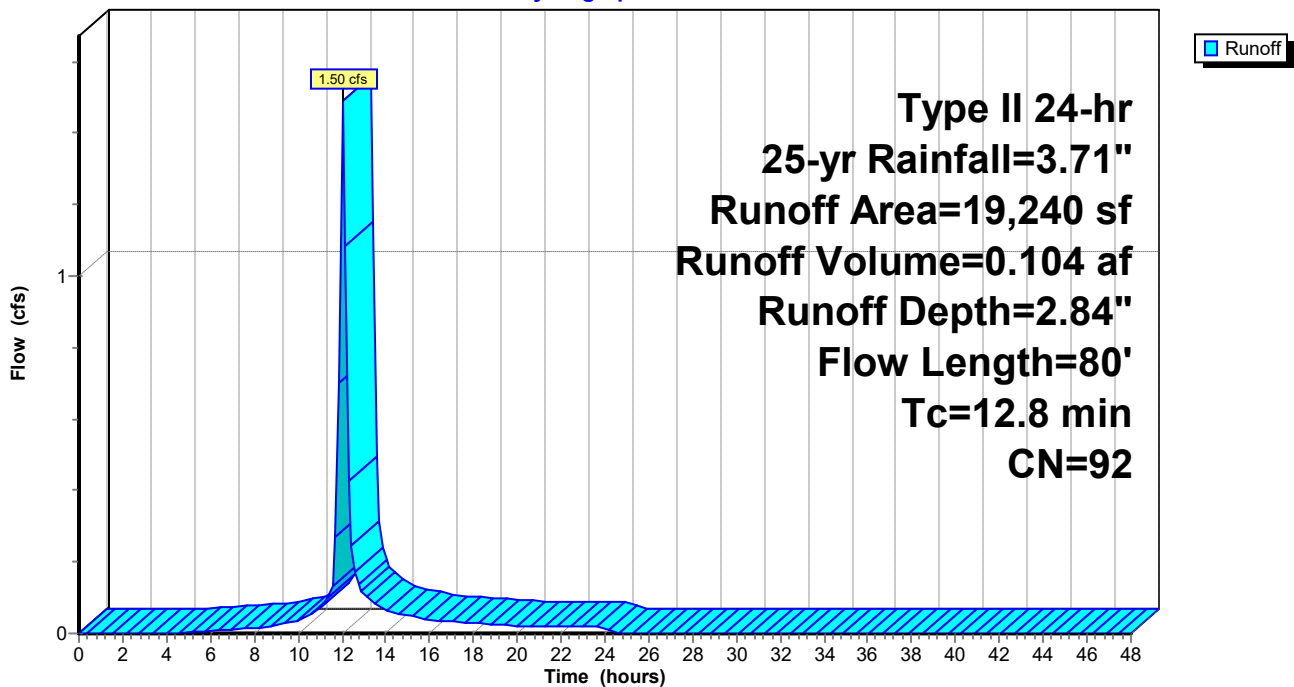

Plug Power - Proposed Conditions 5-15-21

Type II 24-hr 25-yr Rainfall=3.71"

Prepared by {enter your company name here}

Printed 5/20/2021

HydroCAD® 10.10-5a s/n 11585 © 2020 HydroCAD Software Solutions LLC

Page 171

Summary for Subcatchment 12S: Area to CB#2

Runoff = 0.88 cfs @ 12.03 hrs, Volume= 0.060 af, Depth= 2.55"

Runoff by SCS TR-20 method, UH=SCS, Weighted-CN, Time Span= 0.00-48.00 hrs, dt= 0.15 hrs
Type II 24-hr 25-yr Rainfall=3.71"

Area (sf)	CN	Description
4,063	98	Roofs, HSG D
1,800	98	Paved parking, HSG D
6,452	80	>75% Grass cover, Good, HSG D
12,315	89	Weighted Average
6,452		52.39% Pervious Area
5,863		47.61% Impervious Area

Tc (min)	Length (feet)	Slope (ft/ft)	Velocity (ft/sec)	Capacity (cfs)	Description
12.4	65	0.0200	0.09		Sheet Flow, 65' Overland Flow
					Grass: Dense n= 0.240 P2= 2.14"
0.4	15	0.0100	0.58		Sheet Flow, 15' Overland Flow
					Smooth surfaces n= 0.011 P2= 2.14"
12.8	80	Total			

Subcatchment 12S: Area to CB#2

Hydrograph

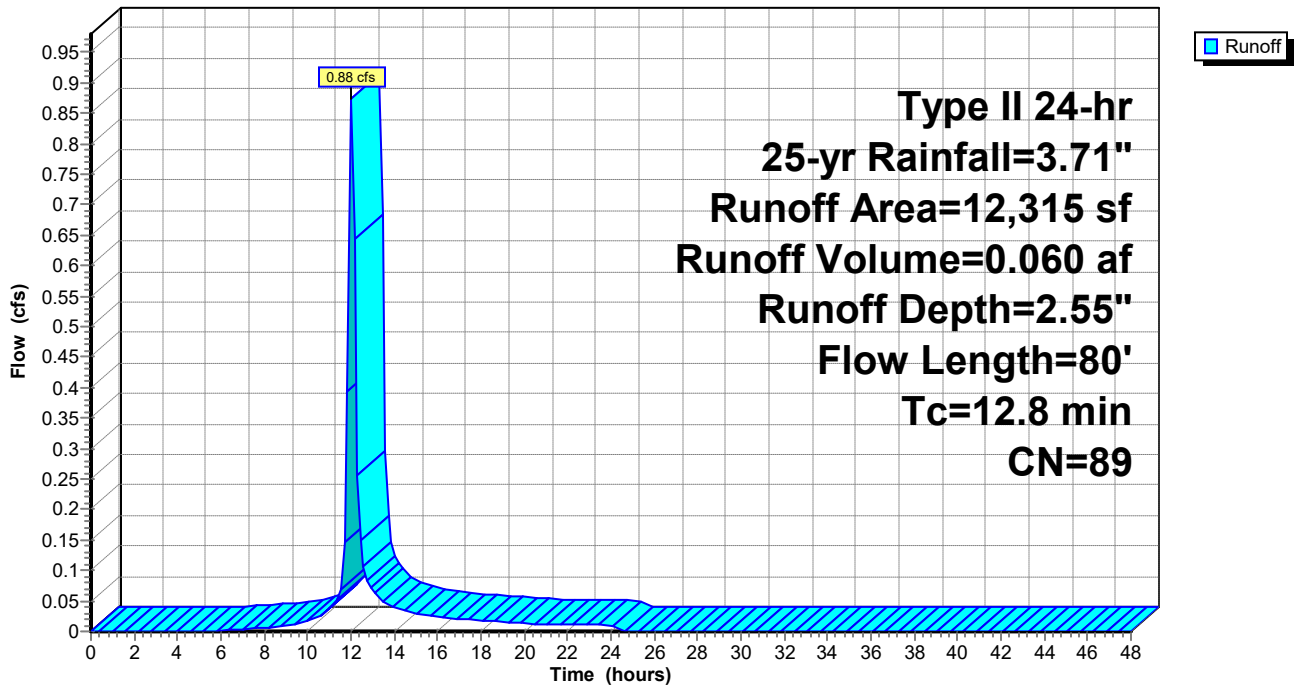

Plug Power - Proposed Conditions 5-15-21

Type II 24-hr 25-yr Rainfall=3.71"

Prepared by {enter your company name here}

Printed 5/20/2021

HydroCAD® 10.10-5a s/n 11585 © 2020 HydroCAD Software Solutions LLC

Page 172

Summary for Subcatchment 14S: Area to CB#3

Runoff = 1.10 cfs @ 12.13 hrs, Volume= 0.086 af, Depth= 2.46"

Runoff by SCS TR-20 method, UH=SCS, Weighted-CN, Time Span= 0.00-48.00 hrs, dt= 0.15 hrs
Type II 24-hr 25-yr Rainfall=3.71"

Area (sf)	CN	Description
8,620	98	Paved parking, HSG D
9,725	80	>75% Grass cover, Good, HSG D
18,345	88	Weighted Average
9,725		53.01% Pervious Area
8,620		46.99% Impervious Area

Tc (min)	Length (feet)	Slope (ft/ft)	Velocity (ft/sec)	Capacity (cfs)	Description
17.5	100	0.0200	0.10		Sheet Flow, 100' Overland Flow Grass: Dense n= 0.240 P2= 2.14"
1.4	130	0.0100	1.50		Shallow Concentrated Flow, 130' Shallow Conc. Flow Grassed Waterway Kv= 15.0 fps
0.2	30	0.0200	2.87		Shallow Concentrated Flow, 30' Shallow Conc. Flow Paved Kv= 20.3 fps
19.1	260	Total			

Subcatchment 14S: Area to CB#3

Hydrograph

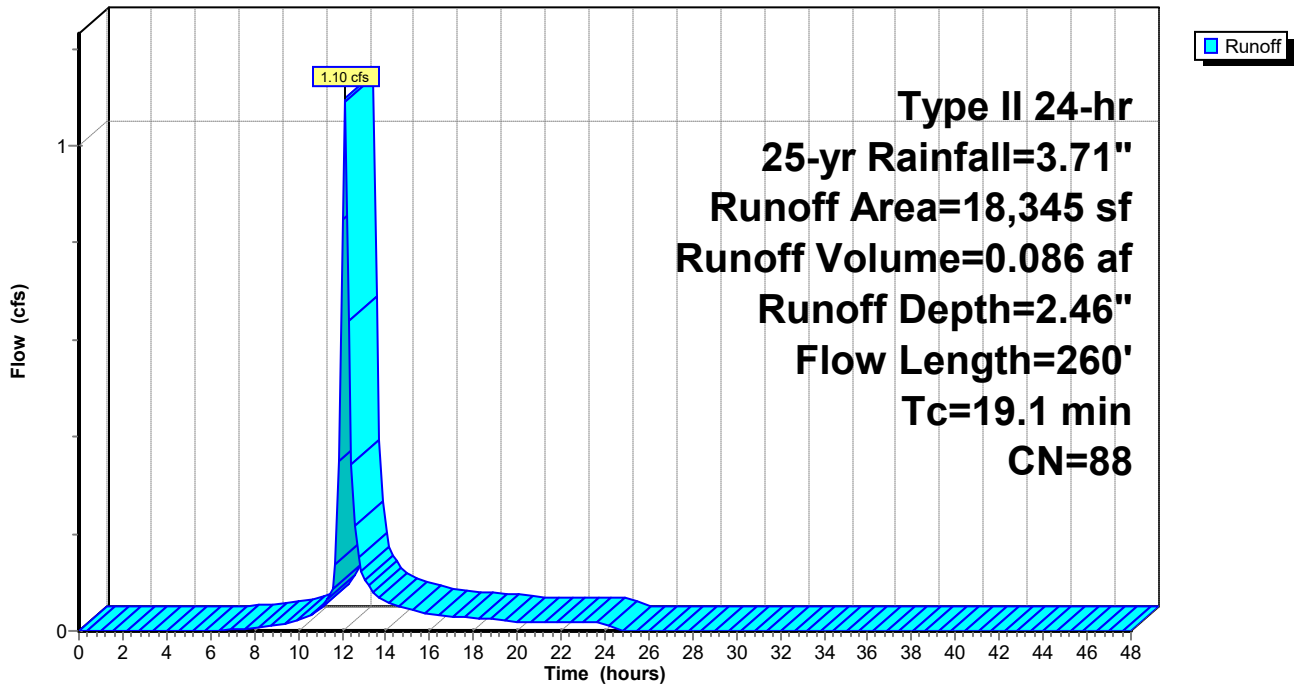

Plug Power - Proposed Conditions 5-15-21

Type II 24-hr 25-yr Rainfall=3.71"

Prepared by {enter your company name here}

Printed 5/20/2021

HydroCAD® 10.10-5a s/n 11585 © 2020 HydroCAD Software Solutions LLC

Page 173

Summary for Subcatchment 18S: Area to YD#2

Runoff = 1.20 cfs @ 12.17 hrs, Volume= 0.102 af, Depth= 1.96"

Runoff by SCS TR-20 method, UH=SCS, Weighted-CN, Time Span= 0.00-48.00 hrs, dt= 0.15 hrs
Type II 24-hr 25-yr Rainfall=3.71"

Area (sf)	CN	Adj	Description
19,675	80		>75% Grass cover, Good, HSG D
7,525	98		Unconnected pavement, HSG D
27,200	85	82	Weighted Average, UI Adjusted
19,675			72.33% Pervious Area
7,525			27.67% Impervious Area
7,525			100.00% Unconnected

Tc (min)	Length (feet)	Slope (ft/ft)	Velocity (ft/sec)	Capacity (cfs)	Description
23.0	100	0.0100	0.07		Sheet Flow, 100' Overland Flow
					Grass: Dense n= 0.240 P2= 2.14"
0.4	40	0.0100	1.50		Shallow Concentrated Flow, 40' Shallow Conc. Flow
					Grassed Waterway Kv= 15.0 fps
23.4	140	Total			

Subcatchment 18S: Area to YD#2

Hydrograph

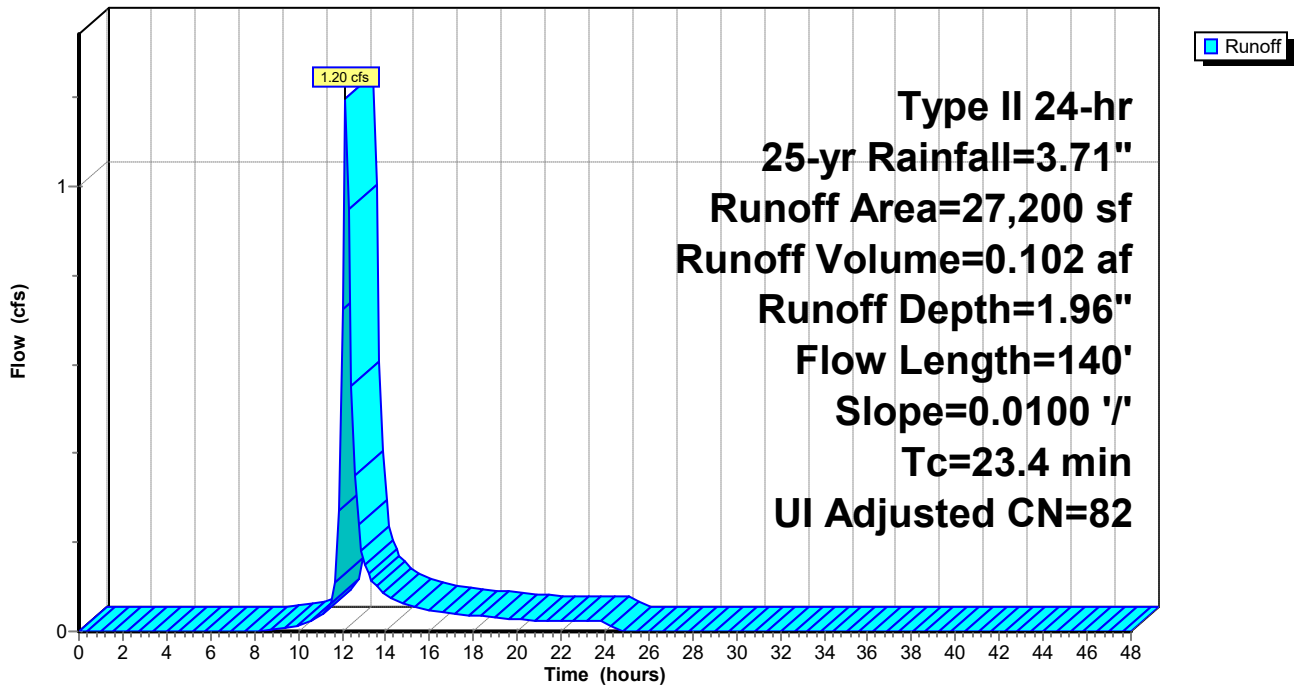

Plug Power - Proposed Conditions 5-15-21

Type II 24-hr 25-yr Rainfall=3.71"

Prepared by {enter your company name here}

Printed 5/20/2021

HydroCAD® 10.10-5a s/n 11585 © 2020 HydroCAD Software Solutions LLC

Page 174

Summary for Subcatchment 20S: Eastern Area Overland to Gravel Storage

Runoff = 16.96 cfs @ 12.25 hrs, Volume= 1.726 af, Depth= 2.74"

Runoff by SCS TR-20 method, UH=SCS, Weighted-CN, Time Span= 0.00-48.00 hrs, dt= 0.15 hrs
 Type II 24-hr 25-yr Rainfall=3.71"

Area (sf)	CN	Description
* 77,480	80	Gravel Storage Area, Good, HSG D
80,190	98	Paved parking, HSG D
77,985	98	Roofs, HSG D
47,575	98	Unconnected pavement, HSG D
46,080	80	>75% Grass cover, Good, HSG D
329,310	91	Weighted Average
123,560		37.52% Pervious Area
205,750		62.48% Impervious Area
47,575		23.12% Unconnected

Tc (min)	Length (feet)	Slope (ft/ft)	Velocity (ft/sec)	Capacity (cfs)	Description
16.5	75	0.0130	0.08		Sheet Flow, 75' Overland Flow Grass: Dense n= 0.240 P2= 2.14"
12.3	25	0.0030	0.03		Sheet Flow, 25' Overland Flow Grass: Dense n= 0.240 P2= 2.14"
0.2	30	0.0300	2.60		Shallow Concentrated Flow, 30' Shallow Conc. Flow Grassed Waterway Kv= 15.0 fps
1.2	200	0.0200	2.87		Shallow Concentrated Flow, 200' Shallow Conc. Flow Paved Kv= 20.3 fps
30.2	330	Total			

Subcatchment 20S: Eastern Area Overland to Gravel Storage

Hydrograph

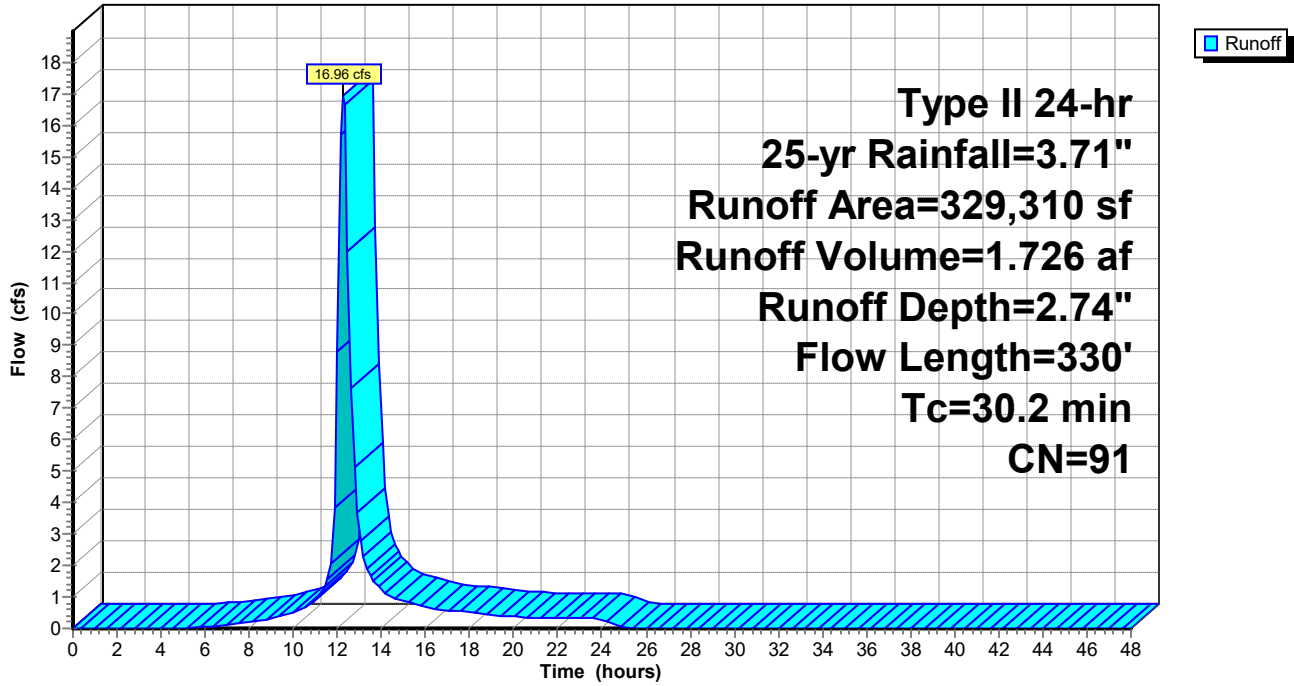

Plug Power - Proposed Conditions 5-15-21

Type II 24-hr 25-yr Rainfall=3.71"

Prepared by {enter your company name here}

Printed 5/20/2021

HydroCAD® 10.10-5a s/n 11585 © 2020 HydroCAD Software Solutions LLC

Page 176

Summary for Subcatchment 24S: Area to YD#11

Runoff = 2.53 cfs @ 12.10 hrs, Volume= 0.197 af, Depth= 2.65"

Runoff by SCS TR-20 method, UH=SCS, Weighted-CN, Time Span= 0.00-48.00 hrs, dt= 0.15 hrs
Type II 24-hr 25-yr Rainfall=3.71"

Area (sf)	CN	Description
3,925	98	Paved parking, HSG D
17,935	80	>75% Grass cover, Good, HSG D
17,040	98	Roofs, HSG D
38,900	90	Weighted Average
17,935		46.11% Pervious Area
20,965		53.89% Impervious Area

Tc (min)	Length (feet)	Slope (ft/ft)	Velocity (ft/sec)	Capacity (cfs)	Description
17.3	70	0.0100	0.07		Sheet Flow, 70' Overland Flow Grass: Dense n= 0.240 P2= 2.14"

Subcatchment 24S: Area to YD#11

Hydrograph

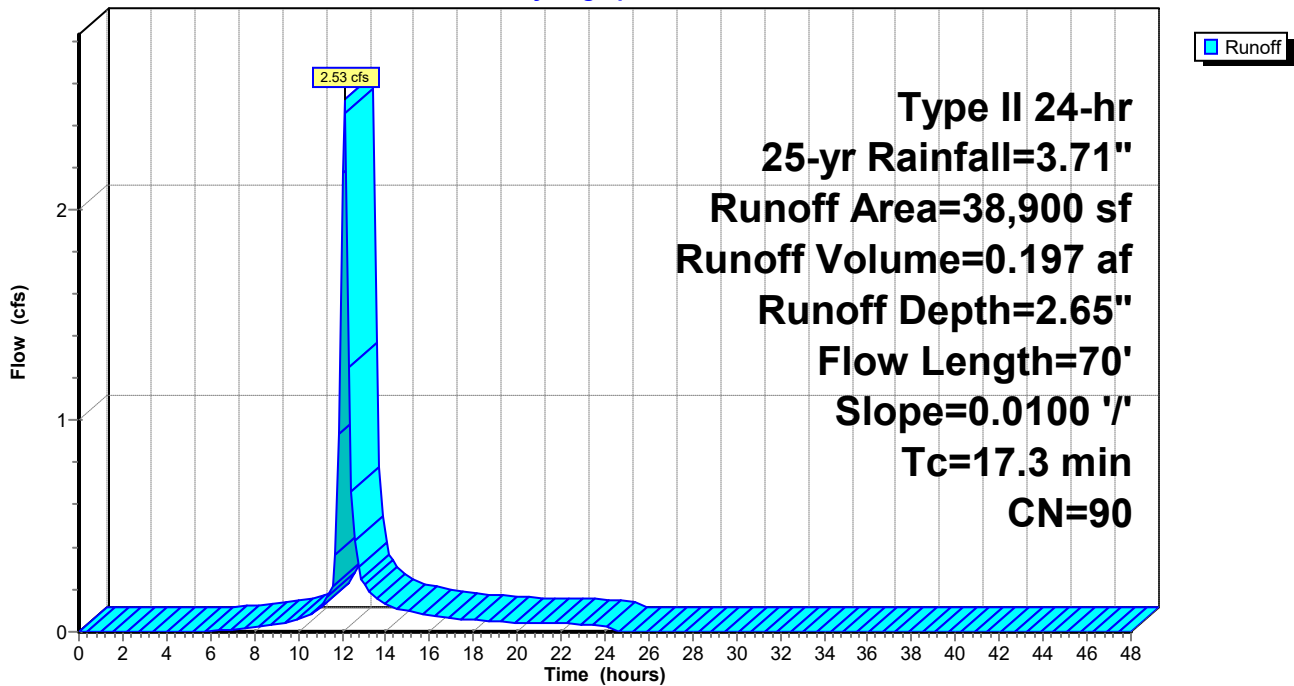

Plug Power - Proposed Conditions 5-15-21

Type II 24-hr 25-yr Rainfall=3.71"

Prepared by {enter your company name here}

Printed 5/20/2021

HydroCAD® 10.10-5a s/n 11585 © 2020 HydroCAD Software Solutions LLC

Page 177

Summary for Subcatchment 26S: Area to CB#4

Runoff = 2.76 cfs @ 12.10 hrs, Volume= 0.216 af, Depth= 2.74"

Runoff by SCS TR-20 method, UH=SCS, Weighted-CN, Time Span= 0.00-48.00 hrs, dt= 0.15 hrs
Type II 24-hr 25-yr Rainfall=3.71"

Area (sf)	CN	Description
510	98	Roofs, HSG D
25,120	98	Paved parking, HSG D
15,575	80	>75% Grass cover, Good, HSG D
41,205	91	Weighted Average
15,575		37.80% Pervious Area
25,630		62.20% Impervious Area

Tc (min)	Length (feet)	Slope (ft/ft)	Velocity (ft/sec)	Capacity (cfs)	Description
16.3	65	0.0100	0.07		Sheet Flow, 65' Overland Flow Grass: Dense n= 0.240 P2= 2.14"
0.6	35	0.0200	0.91		Sheet Flow, 35' Overland Flow Smooth surfaces n= 0.011 P2= 2.14"
16.9	100	Total			

Subcatchment 26S: Area to CB#4

Hydrograph

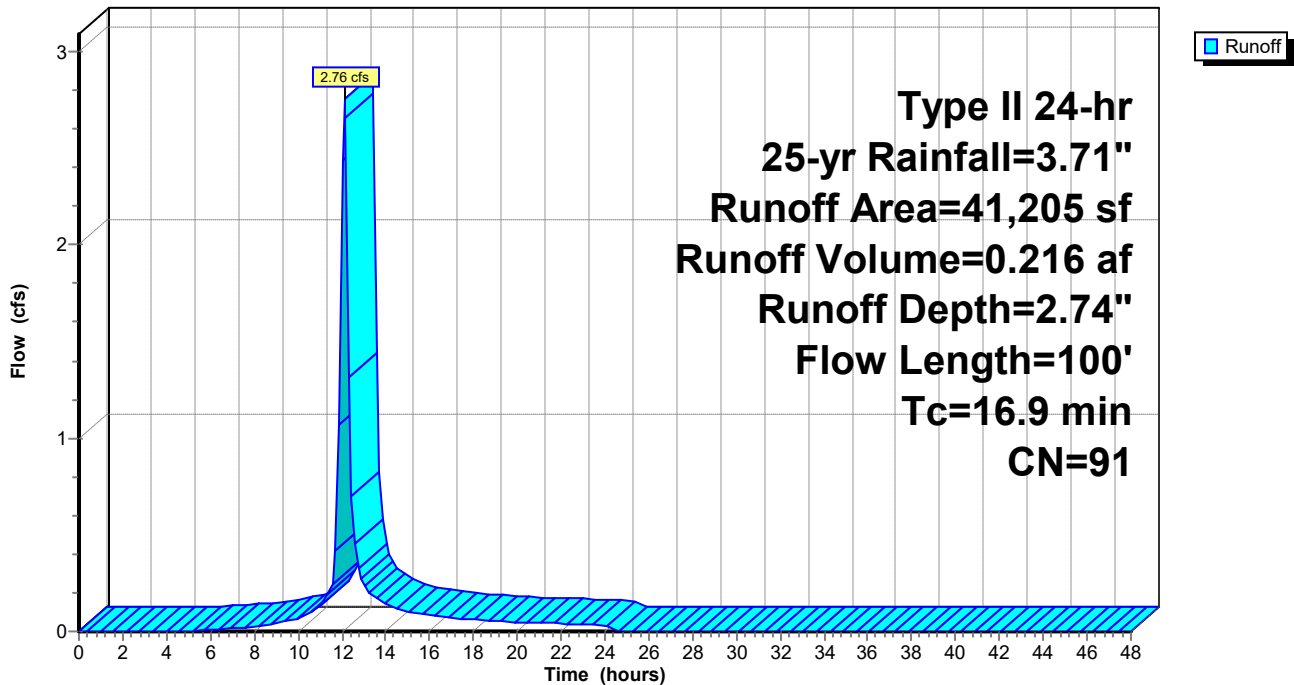

Plug Power - Proposed Conditions 5-15-21

Type II 24-hr 25-yr Rainfall=3.71"

Prepared by {enter your company name here}

Printed 5/20/2021

HydroCAD® 10.10-5a s/n 11585 © 2020 HydroCAD Software Solutions LLC

Page 178

Summary for Subcatchment 29S: Area to CB#15

Runoff = 1.66 cfs @ 11.95 hrs, Volume= 0.113 af, Depth= 3.48"

Runoff by SCS TR-20 method, UH=SCS, Weighted-CN, Time Span= 0.00-48.00 hrs, dt= 0.15 hrs
Type II 24-hr 25-yr Rainfall=3.71"

Area (sf)	CN	Description
17,040	98	Roofs, HSG D
17,040		100.00% Impervious Area

Tc (min)	Length (feet)	Slope (ft/ft)	Velocity (ft/sec)	Capacity (cfs)	Description
5.0					Direct Entry,

Subcatchment 29S: Area to CB#15

Hydrograph

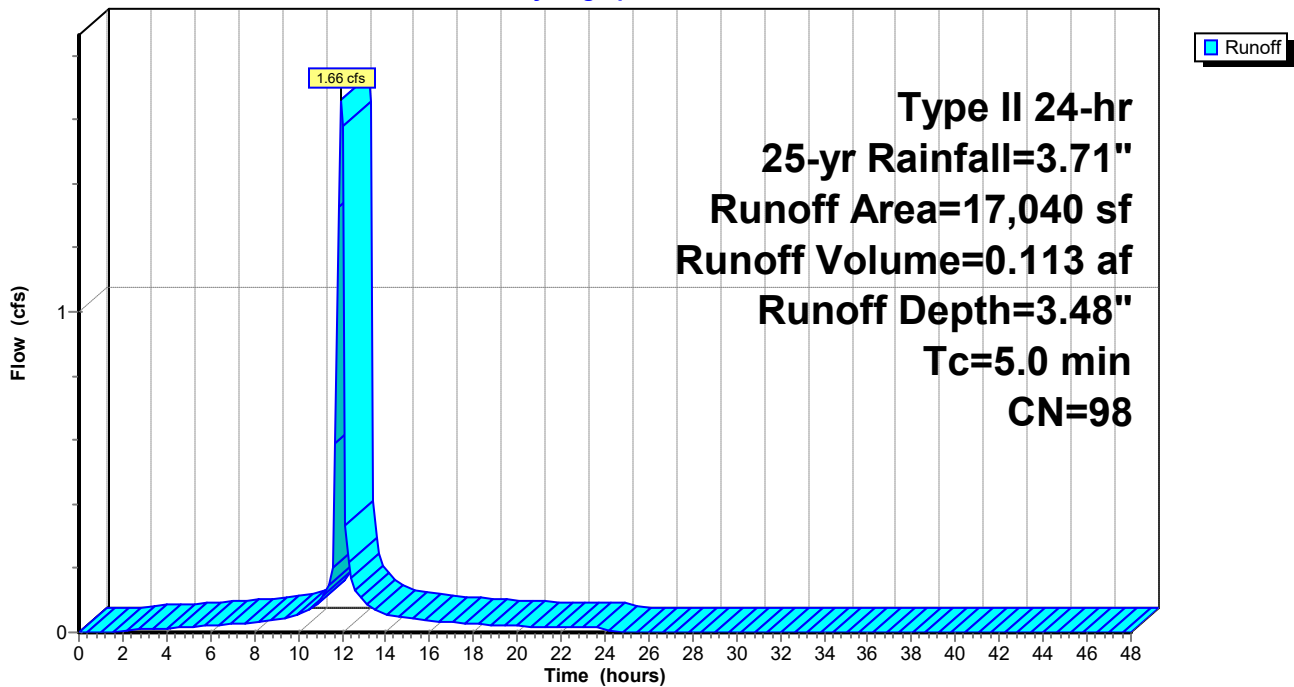

Plug Power - Proposed Conditions 5-15-21

Type II 24-hr 25-yr Rainfall=3.71"

Prepared by {enter your company name here}

Printed 5/20/2021

HydroCAD® 10.10-5a s/n 11585 © 2020 HydroCAD Software Solutions LLC

Page 179

Summary for Subcatchment 30S: Area to CB#18

Runoff = 0.85 cfs @ 12.18 hrs, Volume= 0.072 af, Depth= 1.88"

Runoff by SCS TR-20 method, UH=SCS, Weighted-CN, Time Span= 0.00-48.00 hrs, dt= 0.15 hrs
Type II 24-hr 25-yr Rainfall=3.71"

Area (sf)	CN	Adj	Description
3,025	98		Unconnected pavement, HSG D
17,075	80		>75% Grass cover, Good, HSG D
20,100	83	81	Weighted Average, UI Adjusted
17,075			84.95% Pervious Area
3,025			15.05% Impervious Area
3,025			100.00% Unconnected

Tc (min)	Length (feet)	Slope (ft/ft)	Velocity (ft/sec)	Capacity (cfs)	Description
23.0	100	0.0100	0.07		Sheet Flow, 100' Overland Flow
					Grass: Dense n= 0.240 P2= 2.14"
0.4	40	0.0100	1.50		Shallow Concentrated Flow, 40' Shallow Conc. Flow
					Grassed Waterway Kv= 15.0 fps
23.4	140	Total			

Subcatchment 30S: Area to CB#18

Hydrograph

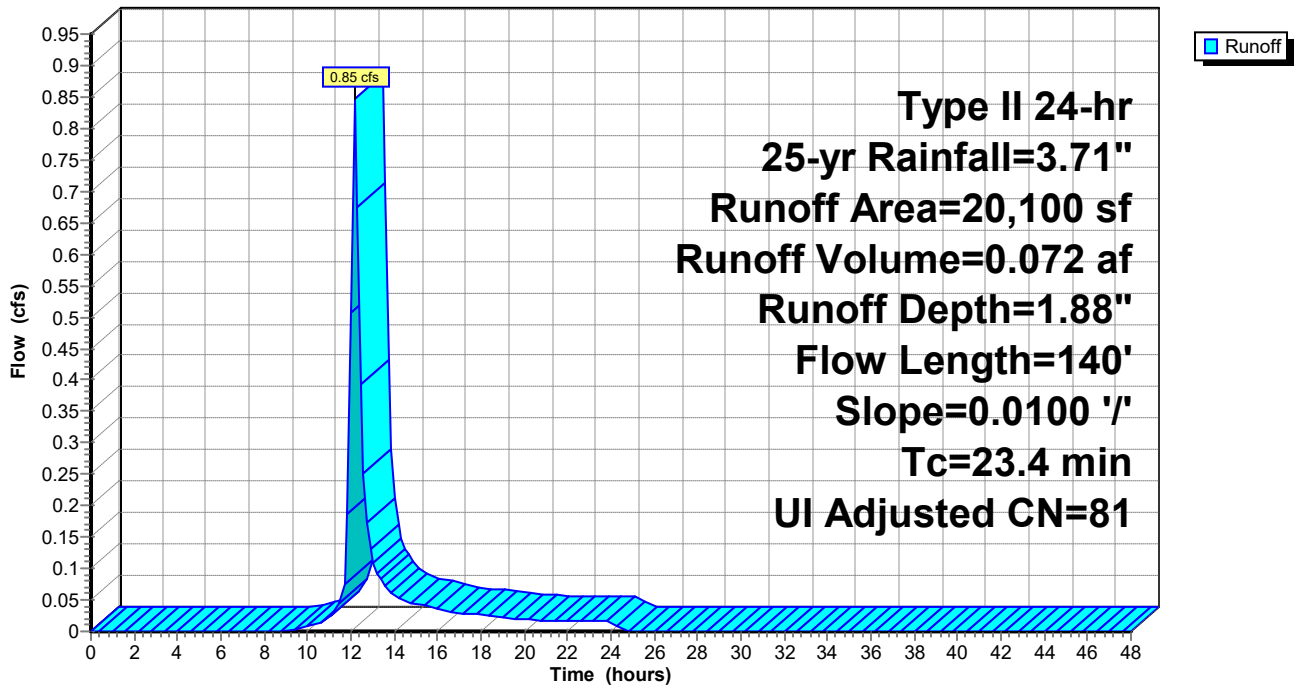

Plug Power - Proposed Conditions 5-15-21

Type II 24-hr 25-yr Rainfall=3.71"

Prepared by {enter your company name here}

Printed 5/20/2021

HydroCAD® 10.10-5a s/n 11585 © 2020 HydroCAD Software Solutions LLC

Page 180

Summary for Subcatchment 32S: Area to CB#7

Runoff = 2.49 cfs @ 12.09 hrs, Volume= 0.197 af, Depth= 2.84"

Runoff by SCS TR-20 method, UH=SCS, Weighted-CN, Time Span= 0.00-48.00 hrs, dt= 0.15 hrs
Type II 24-hr 25-yr Rainfall=3.71"

Area (sf)	CN	Description
25,120	98	Paved parking, HSG D
11,100	80	>75% Grass cover, Good, HSG D
36,220	92	Weighted Average
11,100		30.65% Pervious Area
25,120		69.35% Impervious Area

Tc (min)	Length (feet)	Slope (ft/ft)	Velocity (ft/sec)	Capacity (cfs)	Description
16.3	65	0.0100	0.07		Sheet Flow, 65' Overland Flow
					Grass: Dense n= 0.240 P2= 2.14"
0.6	35	0.0200	0.91		Sheet Flow, 35' Overland Flow
					Smooth surfaces n= 0.011 P2= 2.14"
16.9	100	Total			

Subcatchment 32S: Area to CB#7

Hydrograph

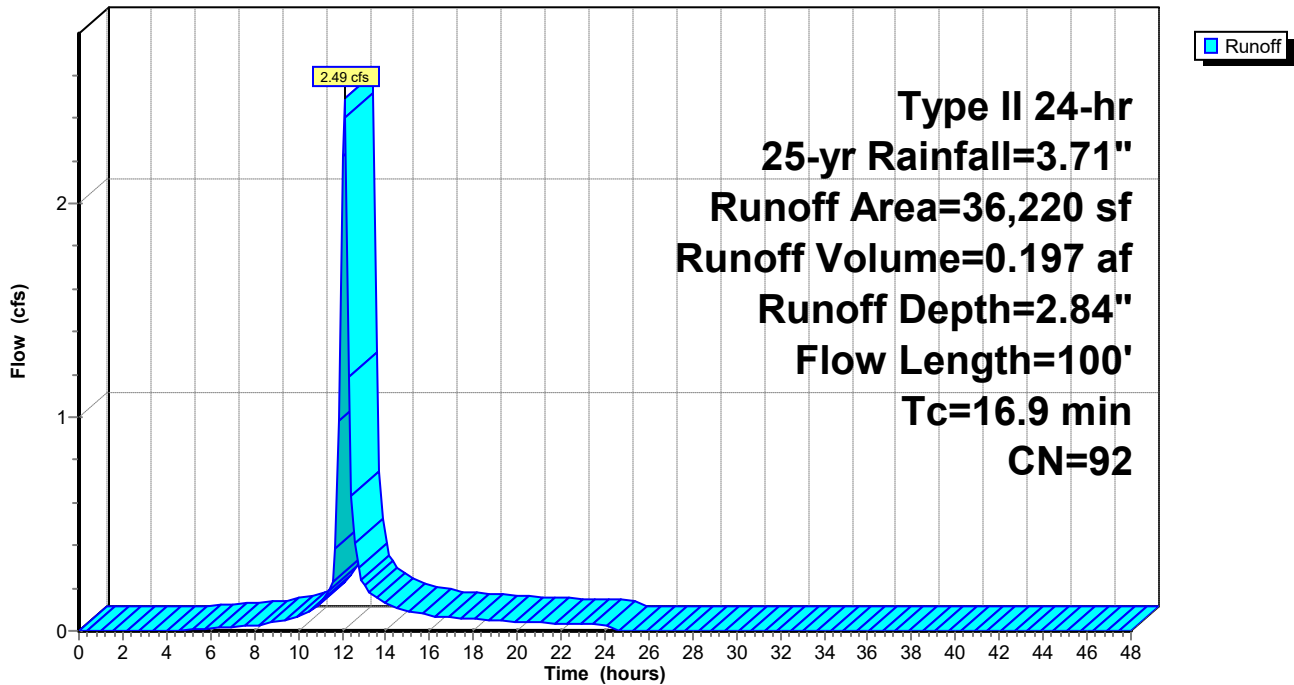

Plug Power - Proposed Conditions 5-15-21

Type II 24-hr 25-yr Rainfall=3.71"

Prepared by {enter your company name here}

Printed 5/20/2021

HydroCAD® 10.10-5a s/n 11585 © 2020 HydroCAD Software Solutions LLC

Page 181

Summary for Subcatchment 36S: Area to CB#9

Runoff = 1.11 cfs @ 12.13 hrs, Volume= 0.087 af, Depth= 2.46"

Runoff by SCS TR-20 method, UH=SCS, Weighted-CN, Time Span= 0.00-48.00 hrs, dt= 0.15 hrs
Type II 24-hr 25-yr Rainfall=3.71"

Area (sf)	CN	Description
5,755	98	Paved parking, HSG D
2,520	98	Unconnected pavement, HSG D
10,200	80	>75% Grass cover, Good, HSG D
18,475	88	Weighted Average
10,200		55.21% Pervious Area
8,275		44.79% Impervious Area
2,520		30.45% Unconnected

Tc (min)	Length (feet)	Slope (ft/ft)	Velocity (ft/sec)	Capacity (cfs)	Description
19.3	80	0.0100	0.07		Sheet Flow, 80' Overland Flow Grass: Dense n= 0.240 P2= 2.14"

Subcatchment 36S: Area to CB#9

Hydrograph

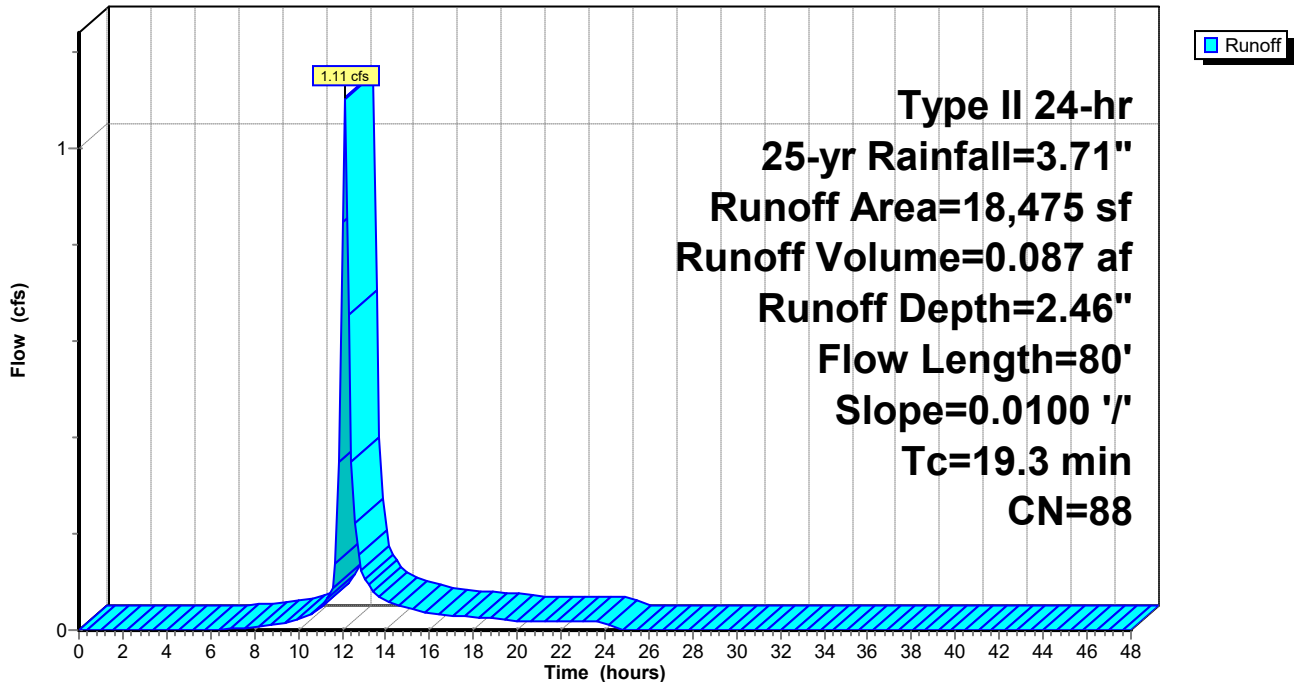

Plug Power - Proposed Conditions 5-15-21

Type II 24-hr 25-yr Rainfall=3.71"

Prepared by {enter your company name here}

Printed 5/20/2021

HydroCAD® 10.10-5a s/n 11585 © 2020 HydroCAD Software Solutions LLC

Page 182

Summary for Subcatchment 38S: Area to CB#10

Runoff = 1.94 cfs @ 12.15 hrs, Volume= 0.154 af, Depth= 2.04"

Runoff by SCS TR-20 method, UH=SCS, Weighted-CN, Time Span= 0.00-48.00 hrs, dt= 0.15 hrs
Type II 24-hr 25-yr Rainfall=3.71"

Area (sf)	CN	Description
8,155	79	Woods, Fair, HSG D
5,920	78	Meadow, non-grazed, HSG D
6,730	98	Paved parking, HSG D
18,845	80	>75% Grass cover, Good, HSG D
39,650	83	Weighted Average
32,920		83.03% Pervious Area
6,730		16.97% Impervious Area

Tc (min)	Length (feet)	Slope (ft/ft)	Velocity (ft/sec)	Capacity (cfs)	Description
20.1	100	0.0140	0.08		Sheet Flow, 100' Overland Flow Grass: Dense n= 0.240 P2= 2.14"
0.5	50	0.0140	1.77		Shallow Concentrated Flow, 50' Shallow Conc. Flow Grassed Waterway Kv= 15.0 fps
20.6	150	Total			

Subcatchment 38S: Area to CB#10

Hydrograph

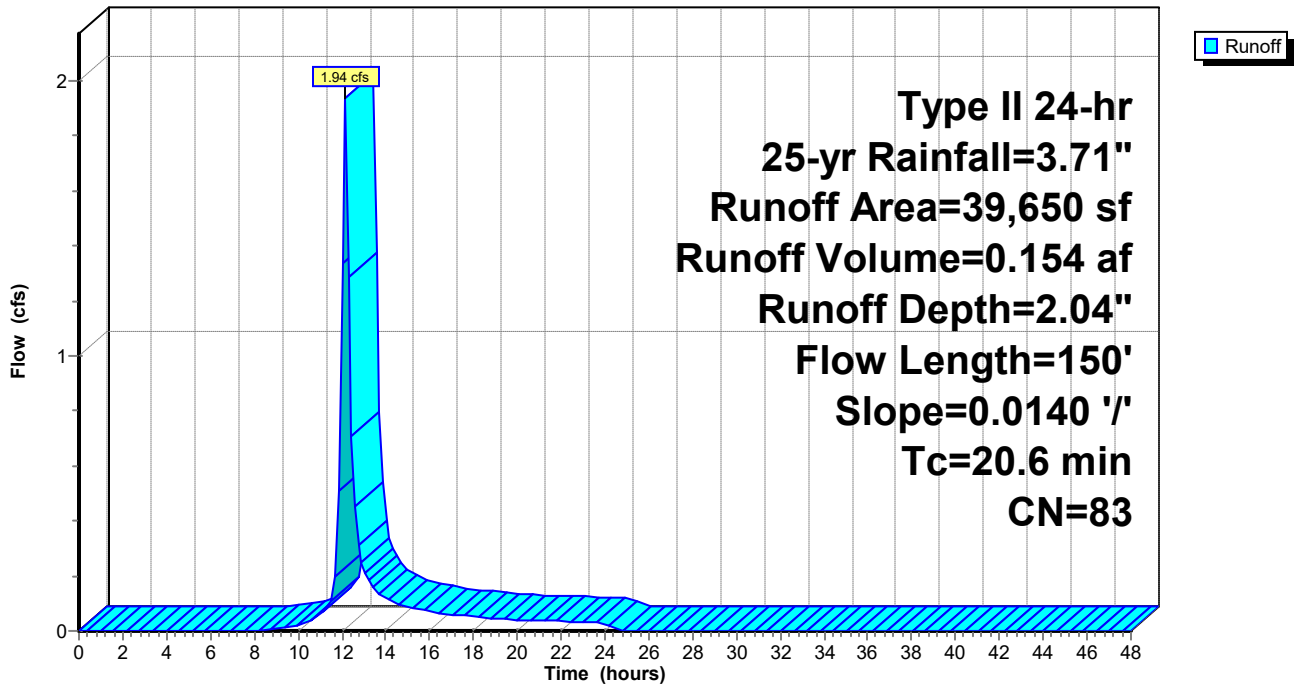

Plug Power - Proposed Conditions 5-15-21

Type II 24-hr 25-yr Rainfall=3.71"

Prepared by {enter your company name here}

Printed 5/20/2021

HydroCAD® 10.10-5a s/n 11585 © 2020 HydroCAD Software Solutions LLC

Page 183

Summary for Subcatchment 40S: Area to CB#11

Runoff = 2.28 cfs @ 12.15 hrs, Volume= 0.209 af, Depth= 3.48"

Runoff by SCS TR-20 method, UH=SCS, Weighted-CN, Time Span= 0.00-48.00 hrs, dt= 0.15 hrs
Type II 24-hr 25-yr Rainfall=3.71"

Area (sf)	CN	Description
4,960	98	Paved parking, HSG D
26,535	98	Paved parking, HSG D
31,495	98	Weighted Average
31,495		100.00% Impervious Area

Tc (min)	Length (feet)	Slope (ft/ft)	Velocity (ft/sec)	Capacity (cfs)	Description
21.4	100	0.0120	0.08		Sheet Flow, 100' Overland Flow Grass: Dense n= 0.240 P2= 2.14"
0.7	70	0.0120	1.64		Shallow Concentrated Flow, 70' Shallow Conc. Flow Grassed Waterway Kv= 15.0 fps
22.1	170	Total			

Subcatchment 40S: Area to CB#11

Hydrograph

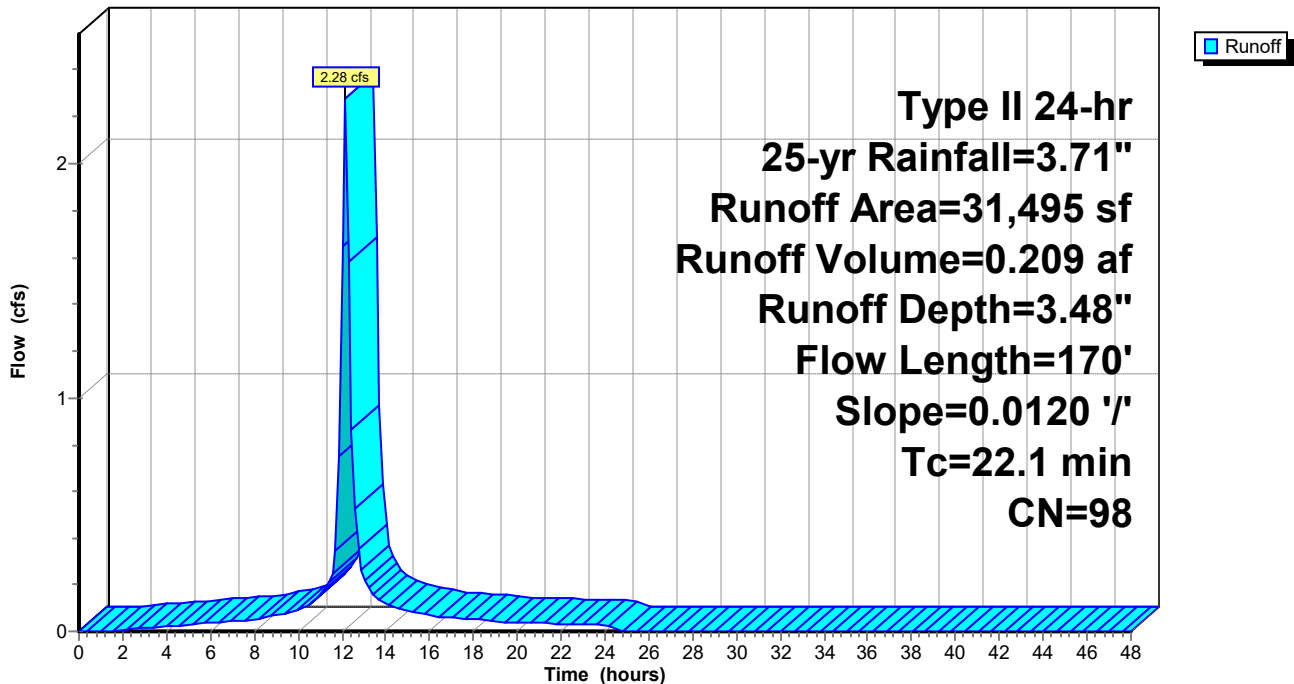

Plug Power - Proposed Conditions 5-15-21

Type II 24-hr 25-yr Rainfall=3.71"

Prepared by {enter your company name here}

Printed 5/20/2021

HydroCAD® 10.10-5a s/n 11585 © 2020 HydroCAD Software Solutions LLC

Page 184

Summary for Subcatchment 42S: Western Area Overland to Gravel Storage

Runoff = 11.38 cfs @ 11.97 hrs, Volume= 0.658 af, Depth= 2.46"

Runoff by SCS TR-20 method, UH=SCS, Weighted-CN, Time Span= 0.00-48.00 hrs, dt= 0.15 hrs
Type II 24-hr 25-yr Rainfall=3.71"

Area (sf)	CN	Description
* 53,390	80	Gravel Storage Area, Good, HSG D
31,080	98	Paved parking, HSG D
2,460	98	Unconnected pavement, HSG D
26,630	80	>75% Grass cover, Good, HSG D
26,105	98	Roofs, HSG D
139,665	88	Weighted Average
80,020		57.29% Pervious Area
59,645		42.71% Impervious Area
2,460		4.12% Unconnected

Tc (min)	Length (feet)	Slope (ft/ft)	Velocity (ft/sec)	Capacity (cfs)	Description
5.8	25	0.0200	0.07		Sheet Flow, 25' Overland Flow Grass: Dense n= 0.240 P2= 2.14"
0.5	25	0.0200	0.85		Sheet Flow, 25' Overland Flow Smooth surfaces n= 0.011 P2= 2.14"
6.3	50	Total			

Subcatchment 42S: Western Area Overland to Gravel Storage

Hydrograph

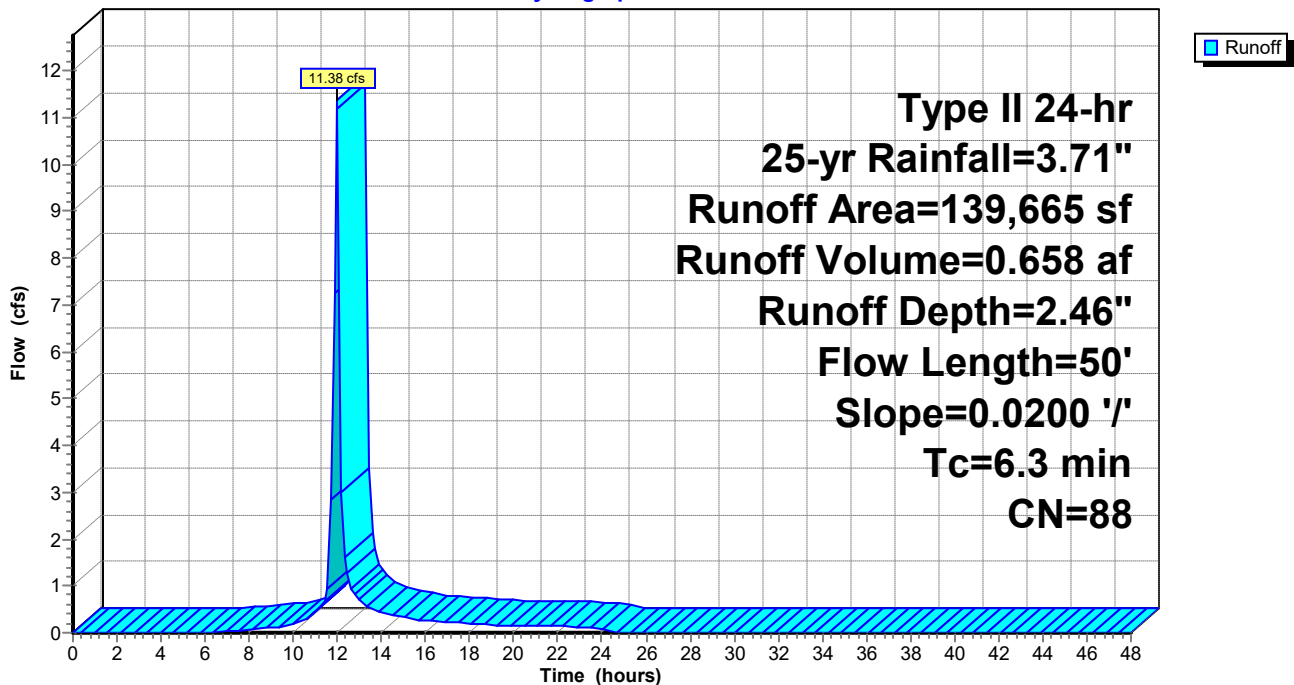

Plug Power - Proposed Conditions 5-15-21

Type II 24-hr 25-yr Rainfall=3.71"

Prepared by {enter your company name here}

Printed 5/20/2021

HydroCAD® 10.10-5a s/n 11585 © 2020 HydroCAD Software Solutions LLC

Page 185

Summary for Subcatchment 43S: North Half of Phase 2 Building

Runoff = 3.56 cfs @ 11.95 hrs, Volume= 0.243 af, Depth= 3.48"

Runoff by SCS TR-20 method, UH=SCS, Weighted-CN, Time Span= 0.00-48.00 hrs, dt= 0.15 hrs
Type II 24-hr 25-yr Rainfall=3.71"

Area (sf)	CN	Description
36,505	98	Roofs, HSG D
36,505		100.00% Impervious Area

Tc (min)	Length (feet)	Slope (ft/ft)	Velocity (ft/sec)	Capacity (cfs)	Description
5.0					Direct Entry,

Subcatchment 43S: North Half of Phase 2 Building

Hydrograph

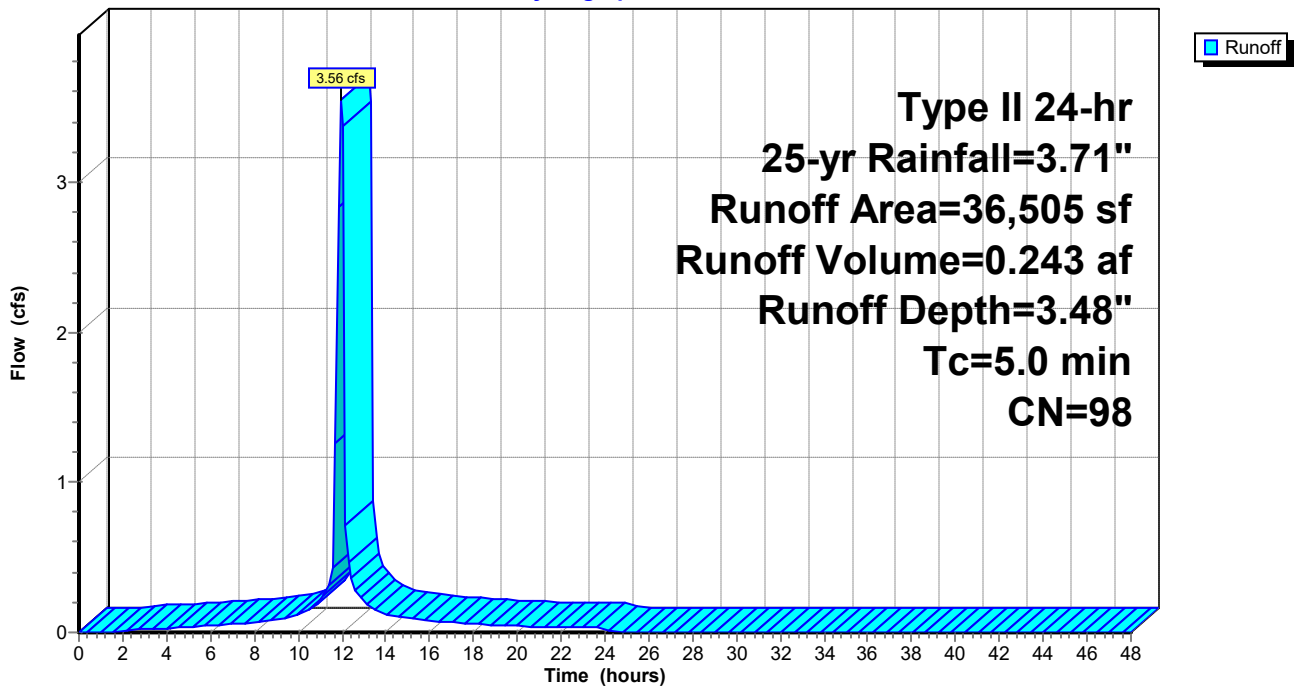

Plug Power - Proposed Conditions 5-15-21

Type II 24-hr 25-yr Rainfall=3.71"

Prepared by {enter your company name here}

Printed 5/20/2021

HydroCAD® 10.10-5a s/n 11585 © 2020 HydroCAD Software Solutions LLC

Page 186

Summary for Subcatchment 45S: South Half of Phase 2 Building

Runoff = 3.15 cfs @ 11.95 hrs, Volume= 0.215 af, Depth= 3.48"

Runoff by SCS TR-20 method, UH=SCS, Weighted-CN, Time Span= 0.00-48.00 hrs, dt= 0.15 hrs
Type II 24-hr 25-yr Rainfall=3.71"

Area (sf)	CN	Description
32,290	98	Roofs, HSG D
32,290		100.00% Impervious Area

Tc (min)	Length (feet)	Slope (ft/ft)	Velocity (ft/sec)	Capacity (cfs)	Description
5.0					Direct Entry,

Subcatchment 45S: South Half of Phase 2 Building

Hydrograph

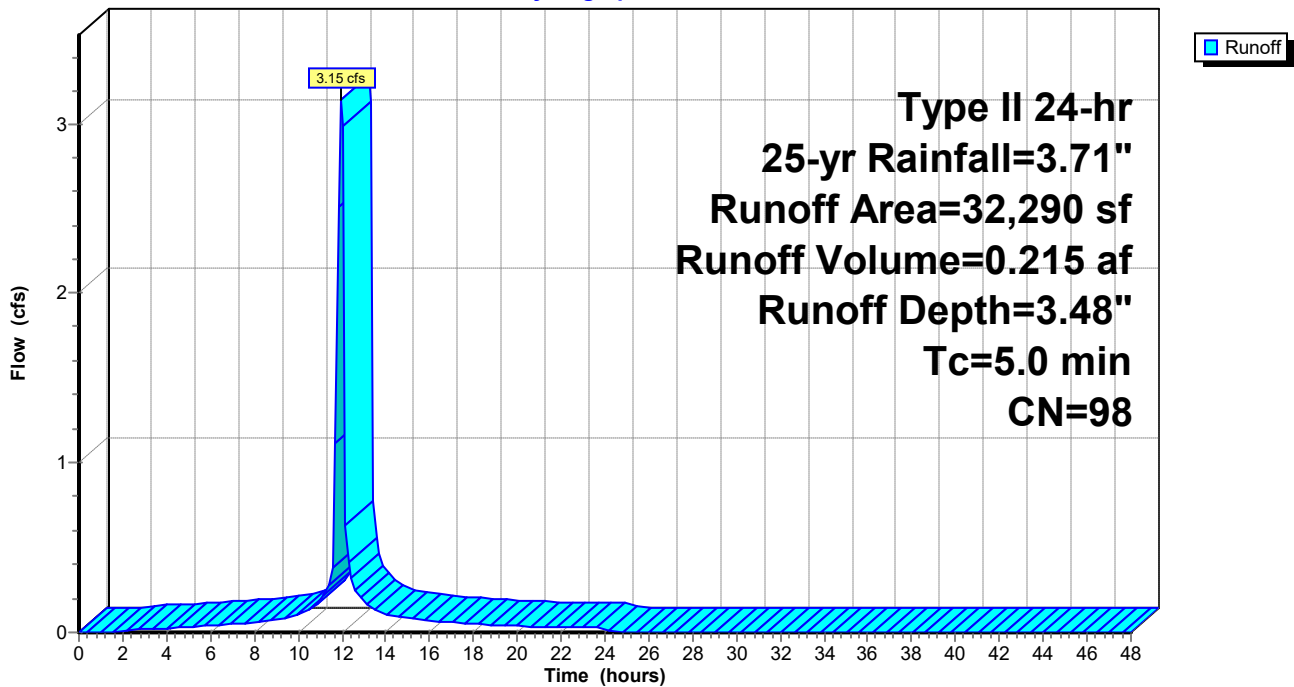

Plug Power - Proposed Conditions 5-15-21

Type II 24-hr 25-yr Rainfall=3.71"

Prepared by {enter your company name here}

Printed 5/20/2021

HydroCAD® 10.10-5a s/n 11585 © 2020 HydroCAD Software Solutions LLC

Page 187

Summary for Subcatchment 48S: Area to YD#1

Runoff = 1.81 cfs @ 12.17 hrs, Volume= 0.154 af, Depth= 2.37"

Runoff by SCS TR-20 method, UH=SCS, Weighted-CN, Time Span= 0.00-48.00 hrs, dt= 0.15 hrs
Type II 24-hr 25-yr Rainfall=3.71"

Area (sf)	CN	Description
2,610	98	Roofs, HSG D
21,165	80	>75% Grass cover, Good, HSG D
10,255	98	Paved parking, HSG D
34,030	87	Weighted Average
21,165		62.20% Pervious Area
12,865		37.80% Impervious Area

Tc (min)	Length (feet)	Slope (ft/ft)	Velocity (ft/sec)	Capacity (cfs)	Description
23.0	100	0.0100	0.07		Sheet Flow, 100' Overland Flow
					Grass: Dense n= 0.240 P2= 2.14"
0.6	50	0.0100	1.50		Shallow Concentrated Flow, 50' Shallow Conc. Flow
					Grassed Waterway Kv= 15.0 fps
23.6	150	Total			

Subcatchment 48S: Area to YD#1

Hydrograph

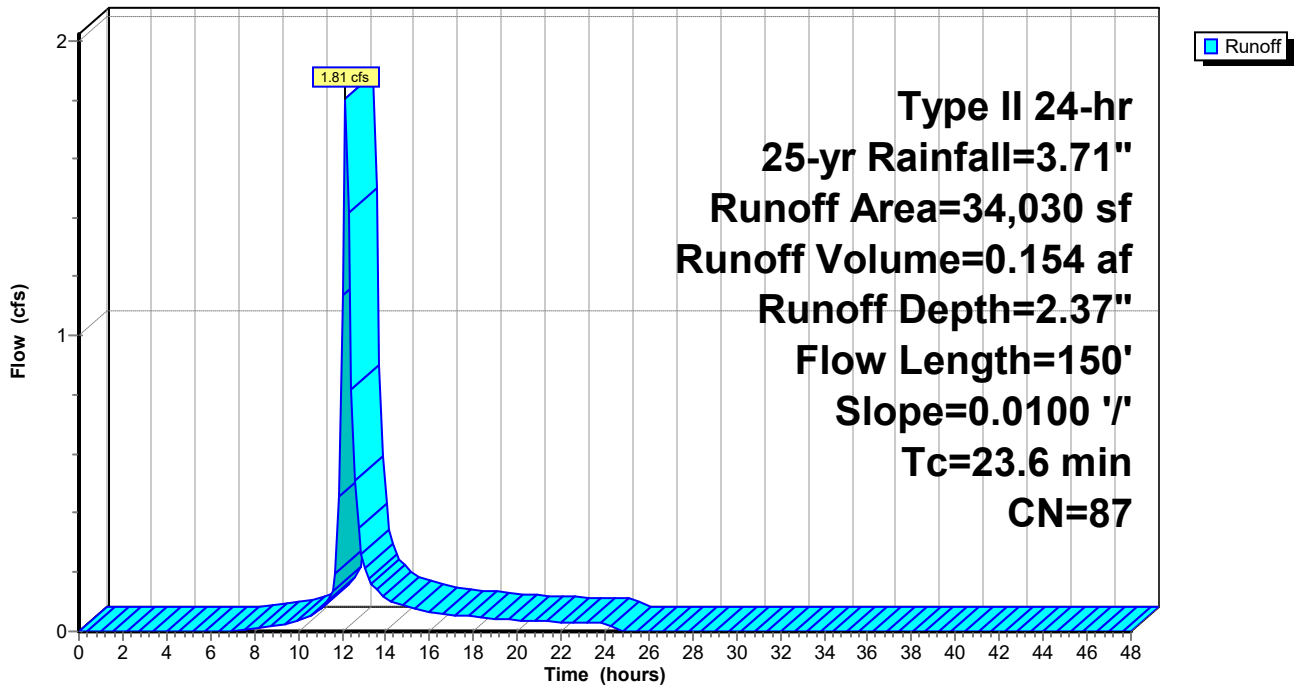

Plug Power - Proposed Conditions 5-15-21

Type II 24-hr 25-yr Rainfall=3.71"

Prepared by {enter your company name here}

Printed 5/20/2021

HydroCAD® 10.10-5a s/n 11585 © 2020 HydroCAD Software Solutions LLC

Page 188

Summary for Subcatchment 49S: Area to YD#3

Runoff = 3.87 cfs @ 12.19 hrs, Volume= 0.344 af, Depth= 2.20"

Runoff by SCS TR-20 method, UH=SCS, Weighted-CN, Time Span= 0.00-48.00 hrs, dt= 0.15 hrs
Type II 24-hr 25-yr Rainfall=3.71"

Area (sf)	CN	Description
20,040	98	Paved parking, HSG D
57,195	80	>75% Grass cover, Good, HSG D
4,600	98	Roofs, HSG D
81,835	85	Weighted Average
57,195		69.89% Pervious Area
24,640		30.11% Impervious Area

Tc (min)	Length (feet)	Slope (ft/ft)	Velocity (ft/sec)	Capacity (cfs)	Description
23.0	100	0.0100	0.07		Sheet Flow, 100' Overland Flow Grass: Dense n= 0.240 P2= 2.14"
0.3	60	0.0200	2.87		Shallow Concentrated Flow, 60' Shallow Conc. Flow Paved Kv= 20.3 fps
2.0	180	0.0100	1.50		Shallow Concentrated Flow, 180' Shallow Conc. Flow Grassed Waterway Kv= 15.0 fps
25.3	340	Total			

Subcatchment 49S: Area to YD#3

Hydrograph

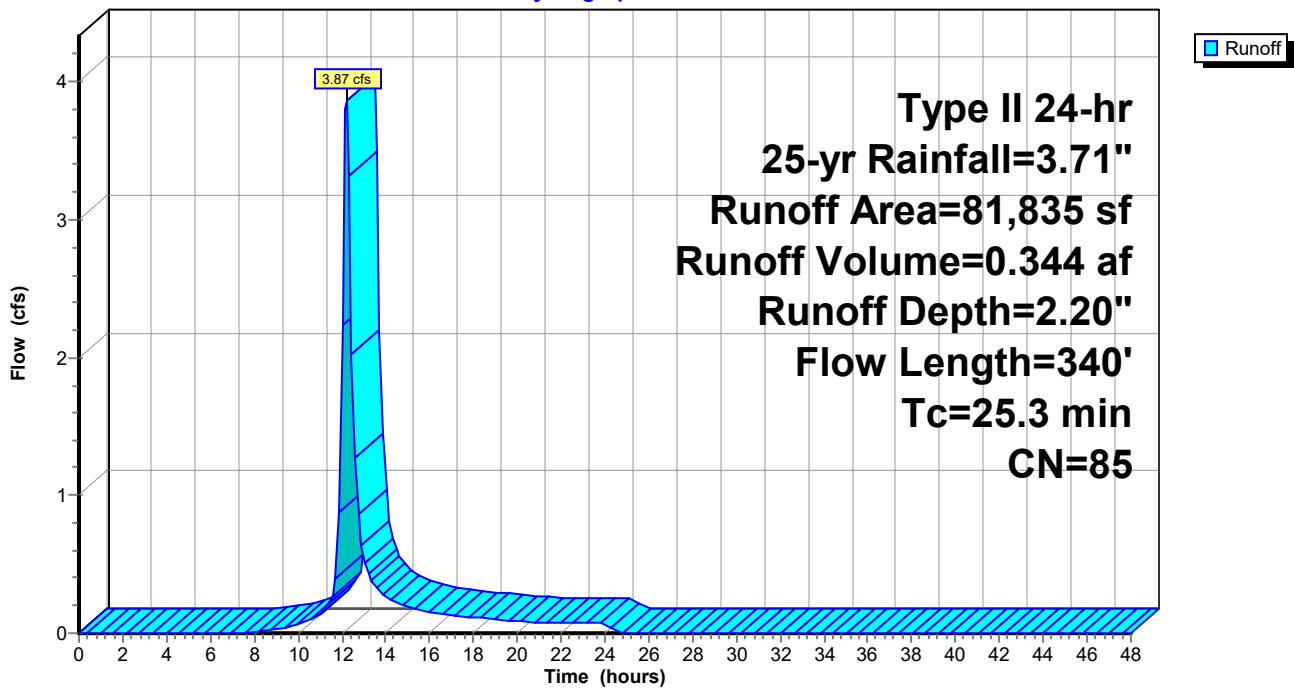

Plug Power - Proposed Conditions 5-15-21

Type II 24-hr 25-yr Rainfall=3.71"

Prepared by {enter your company name here}

Printed 5/20/2021

HydroCAD® 10.10-5a s/n 11585 © 2020 HydroCAD Software Solutions LLC

Page 189

Summary for Subcatchment 52S: Area Overland to Bio-Retention Area

Runoff = 4.33 cfs @ 11.97 hrs, Volume= 0.246 af, Depth= 1.80"

Runoff by SCS TR-20 method, UH=SCS, Weighted-CN, Time Span= 0.00-48.00 hrs, dt= 0.15 hrs
Type II 24-hr 25-yr Rainfall=3.71"

Area (sf)	CN	Description
71,325	80	>75% Grass cover, Good, HSG D
71,325		100.00% Pervious Area

Tc (min)	Length (feet)	Slope (ft/ft)	Velocity (ft/sec)	Capacity (cfs)	Description
3.6	10	0.0100	0.05		Sheet Flow, 10' Overland Flow Grass: Dense n= 0.240 P2= 2.14"
1.8	20	0.2500	0.19		Sheet Flow, 20' Overland Flow Grass: Dense n= 0.240 P2= 2.14"
5.4	30	Total			

Subcatchment 52S: Area Overland to Bio-Retention Area

Hydrograph

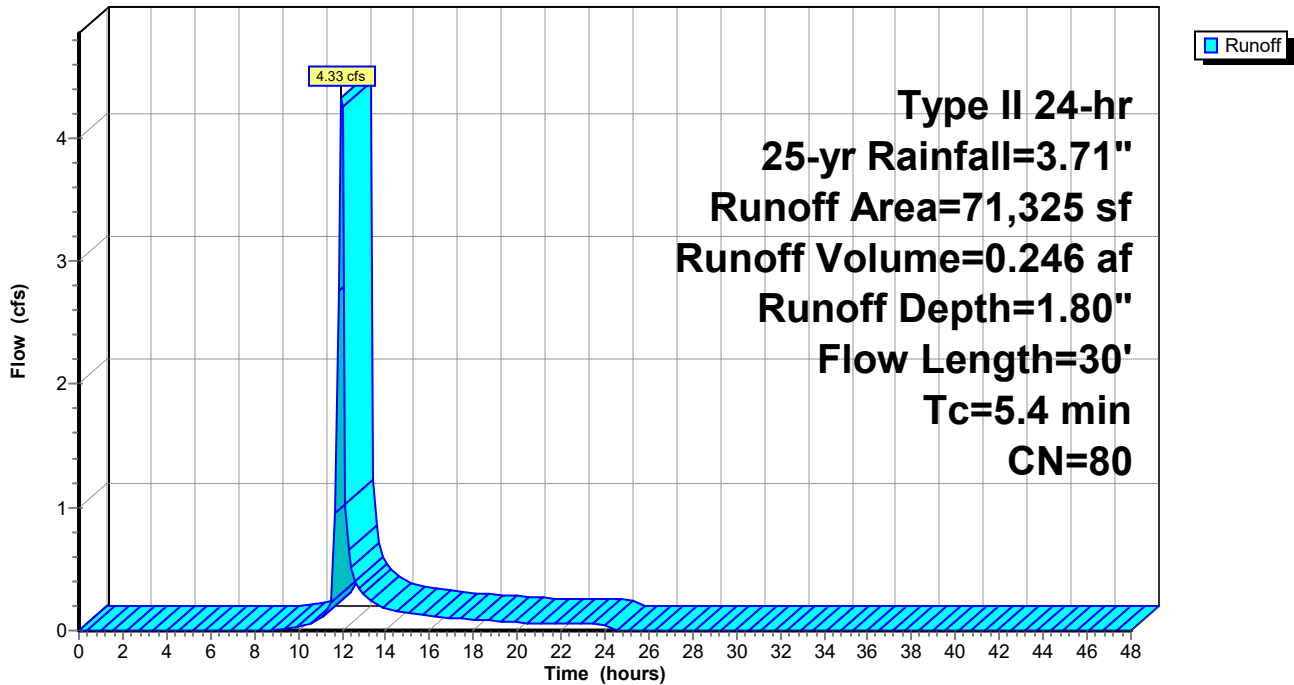

Plug Power - Proposed Conditions 5-15-21

Type II 24-hr 25-yr Rainfall=3.71"

Prepared by {enter your company name here}

Printed 5/20/2021

HydroCAD® 10.10-5a s/n 11585 © 2020 HydroCAD Software Solutions LLC

Page 190

Summary for Subcatchment 53S: Area Overland to Western Swale to Bio-Retention Area

Runoff = 0.36 cfs @ 11.97 hrs, Volume= 0.020 af, Depth= 1.80"

Runoff by SCS TR-20 method, UH=SCS, Weighted-CN, Time Span= 0.00-48.00 hrs, dt= 0.15 hrs
Type II 24-hr 25-yr Rainfall=3.71"

Area (sf)	CN	Description
5,925	80	>75% Grass cover, Good, HSG D
5,925		100.00% Pervious Area

Tc (min)	Length (feet)	Slope (ft/ft)	Velocity (ft/sec)	Capacity (cfs)	Description
5.0					Direct Entry,

Subcatchment 53S: Area Overland to Western Swale to Bio-Retention Area

Hydrograph

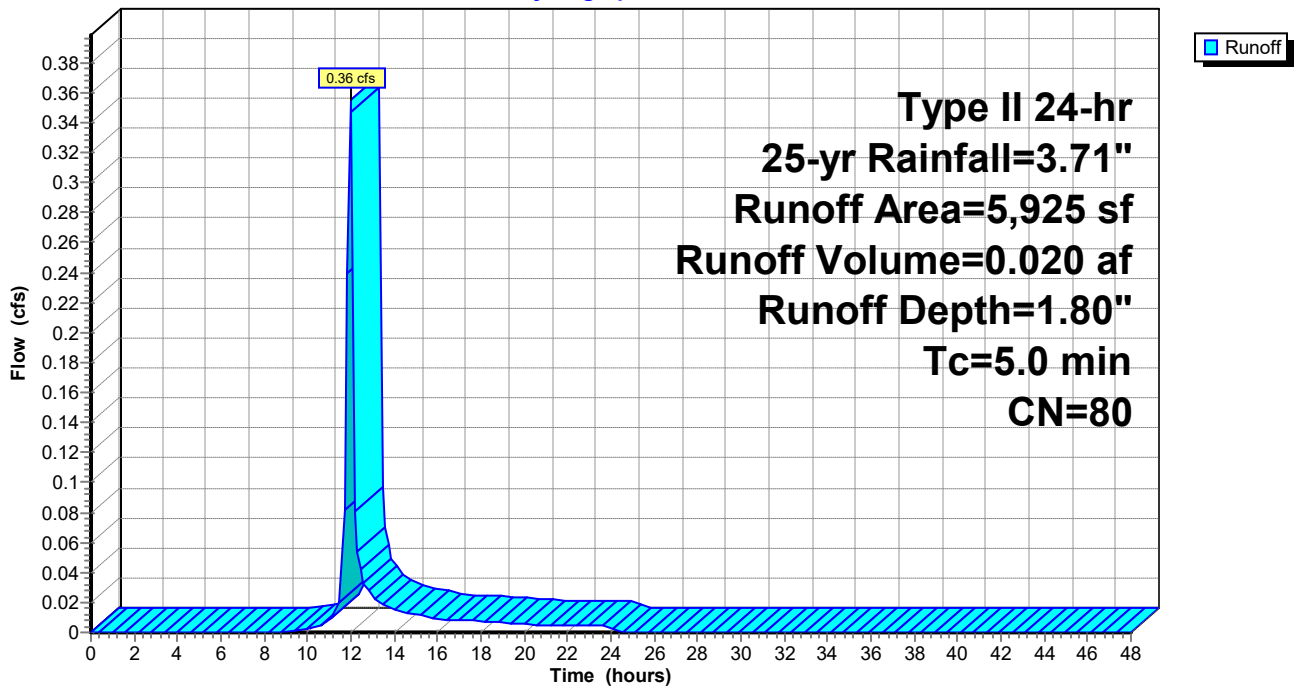

Plug Power - Proposed Conditions 5-15-21

Type II 24-hr 25-yr Rainfall=3.71"

Prepared by {enter your company name here}

Printed 5/20/2021

HydroCAD® 10.10-5a s/n 11585 © 2020 HydroCAD Software Solutions LLC

Page 191

Summary for Subcatchment 54S: Area Overland to Northern Swale to Bio-Retention Area

Runoff = 0.36 cfs @ 11.97 hrs, Volume= 0.021 af, Depth= 1.80"

Runoff by SCS TR-20 method, UH=SCS, Weighted-CN, Time Span= 0.00-48.00 hrs, dt= 0.15 hrs
Type II 24-hr 25-yr Rainfall=3.71"

Area (sf)	CN	Description
6,040	80	>75% Grass cover, Good, HSG D
6,040		100.00% Pervious Area

Tc (min)	Length (feet)	Slope (ft/ft)	Velocity (ft/sec)	Capacity (cfs)	Description
5.0					Direct Entry,

Subcatchment 54S: Area Overland to Northern Swale to Bio-Retention Area

Hydrograph

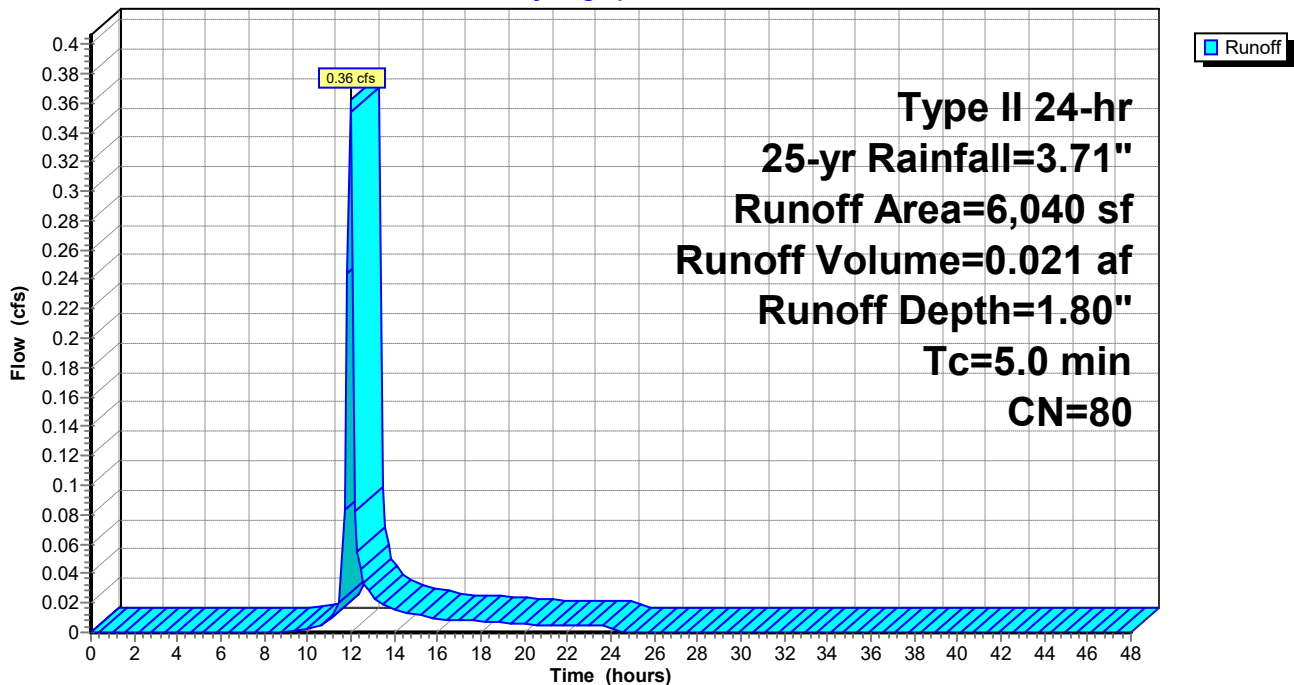

Plug Power - Proposed Conditions 5-15-21

Type II 24-hr 25-yr Rainfall=3.71"

Prepared by {enter your company name here}

Printed 5/20/2021

HydroCAD® 10.10-5a s/n 11585 © 2020 HydroCAD Software Solutions LLC

Page 192

Summary for Subcatchment 55S: Area Overland to Swales to Dry Pond

Runoff = 0.81 cfs @ 11.99 hrs, Volume= 0.046 af, Depth= 1.80"

Runoff by SCS TR-20 method, UH=SCS, Weighted-CN, Time Span= 0.00-48.00 hrs, dt= 0.15 hrs
Type II 24-hr 25-yr Rainfall=3.71"

Area (sf)	CN	Description
13,210	80	>75% Grass cover, Good, HSG D
13,210		100.00% Pervious Area

Tc (min)	Length (feet)	Slope (ft/ft)	Velocity (ft/sec)	Capacity (cfs)	Description
7.6	25	0.0100	0.05		Sheet Flow, 25' Overland Flow Grass: Dense n= 0.240 P2= 2.14"

Subcatchment 55S: Area Overland to Swales to Dry Pond

Hydrograph

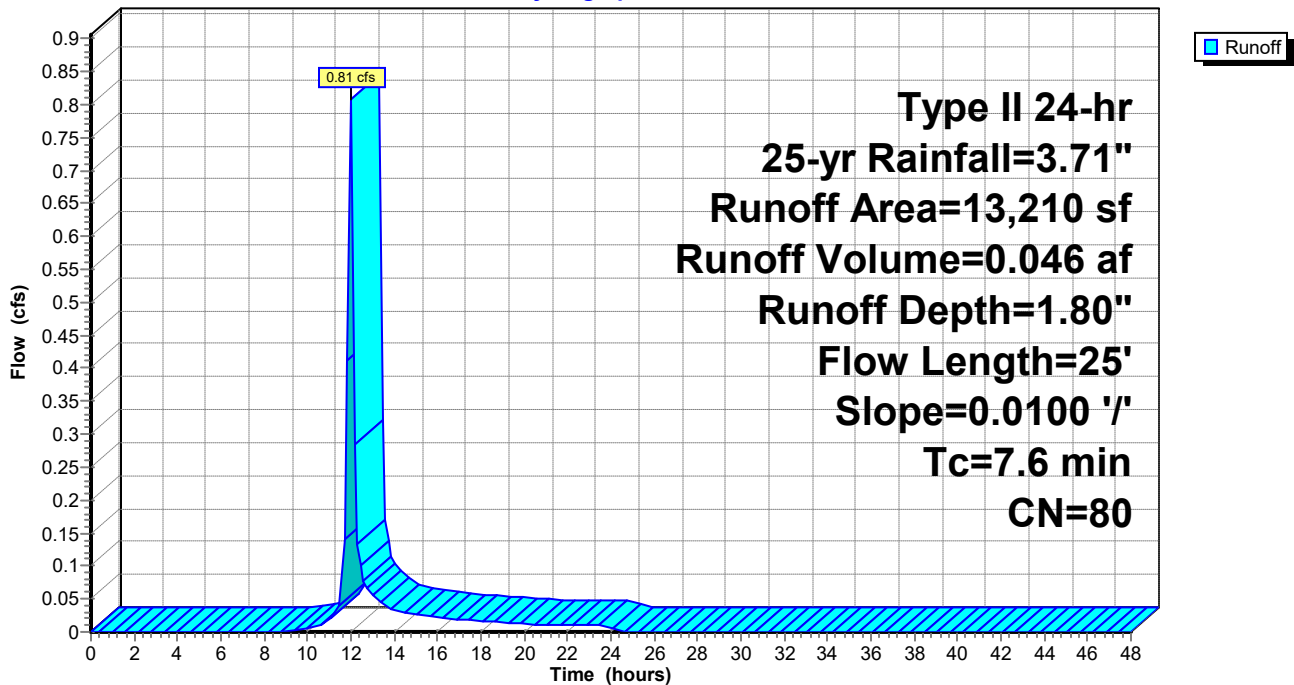

Plug Power - Proposed Conditions 5-15-21

Type II 24-hr 25-yr Rainfall=3.71"

Prepared by {enter your company name here}

Printed 5/20/2021

HydroCAD® 10.10-5a s/n 11585 © 2020 HydroCAD Software Solutions LLC

Page 193

Summary for Subcatchment 56S: Area Overland to Dry Pond

Runoff = 1.16 cfs @ 11.97 hrs, Volume= 0.066 af, Depth= 1.80"

Runoff by SCS TR-20 method, UH=SCS, Weighted-CN, Time Span= 0.00-48.00 hrs, dt= 0.15 hrs
 Type II 24-hr 25-yr Rainfall=3.71"

Area (sf)	CN	Description
19,245	80	>75% Grass cover, Good, HSG D
19,245		100.00% Pervious Area

Tc (min)	Length (feet)	Slope (ft/ft)	Velocity (ft/sec)	Capacity (cfs)	Description
5.0					Direct Entry,

Subcatchment 56S: Area Overland to Dry Pond

Hydrograph

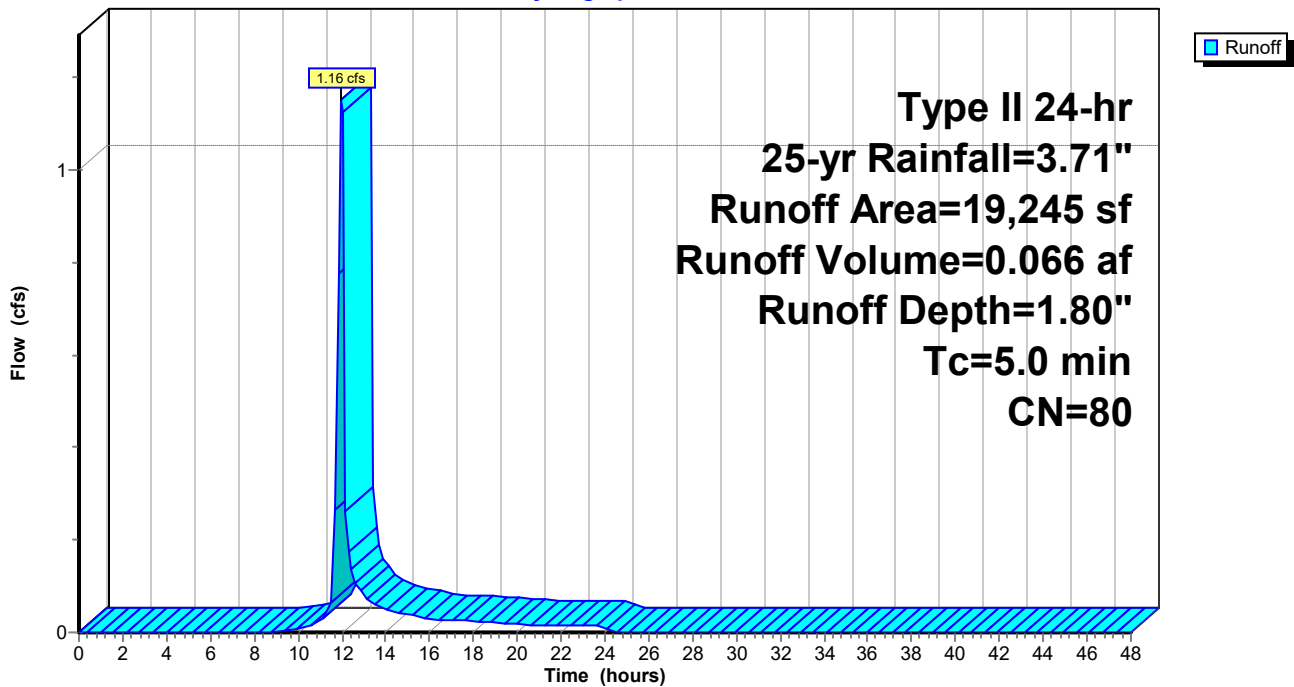

Plug Power - Proposed Conditions 5-15-21

Type II 24-hr 25-yr Rainfall=3.71"

Prepared by {enter your company name here}

Printed 5/20/2021

HydroCAD® 10.10-5a s/n 11585 © 2020 HydroCAD Software Solutions LLC

Page 194

Summary for Subcatchment 57S: Area Overland to North Prop. Line and Wetland Ditch (Central)

Runoff = 1.14 cfs @ 12.02 hrs, Volume= 0.072 af, Depth= 1.59"

Runoff by SCS TR-20 method, UH=SCS, Weighted-CN, Time Span= 0.00-48.00 hrs, dt= 0.15 hrs
Type II 24-hr 25-yr Rainfall=3.71"

Area (sf)	CN	Description
23,585	77	Brush, Fair, HSG D
23,585		100.00% Pervious Area

Tc (min)	Length (feet)	Slope (ft/ft)	Velocity (ft/sec)	Capacity (cfs)	Description
10.6	70	0.0100	0.11		Sheet Flow, 70' Overland Flow Range n= 0.130 P2= 2.14"
0.2	30	0.1000	2.21		Shallow Concentrated Flow, 30' Shallow Conc. Flow Short Grass Pasture Kv= 7.0 fps
10.8	100	Total			

Subcatchment 57S: Area Overland to North Prop. Line and Wetland Ditch (Central)

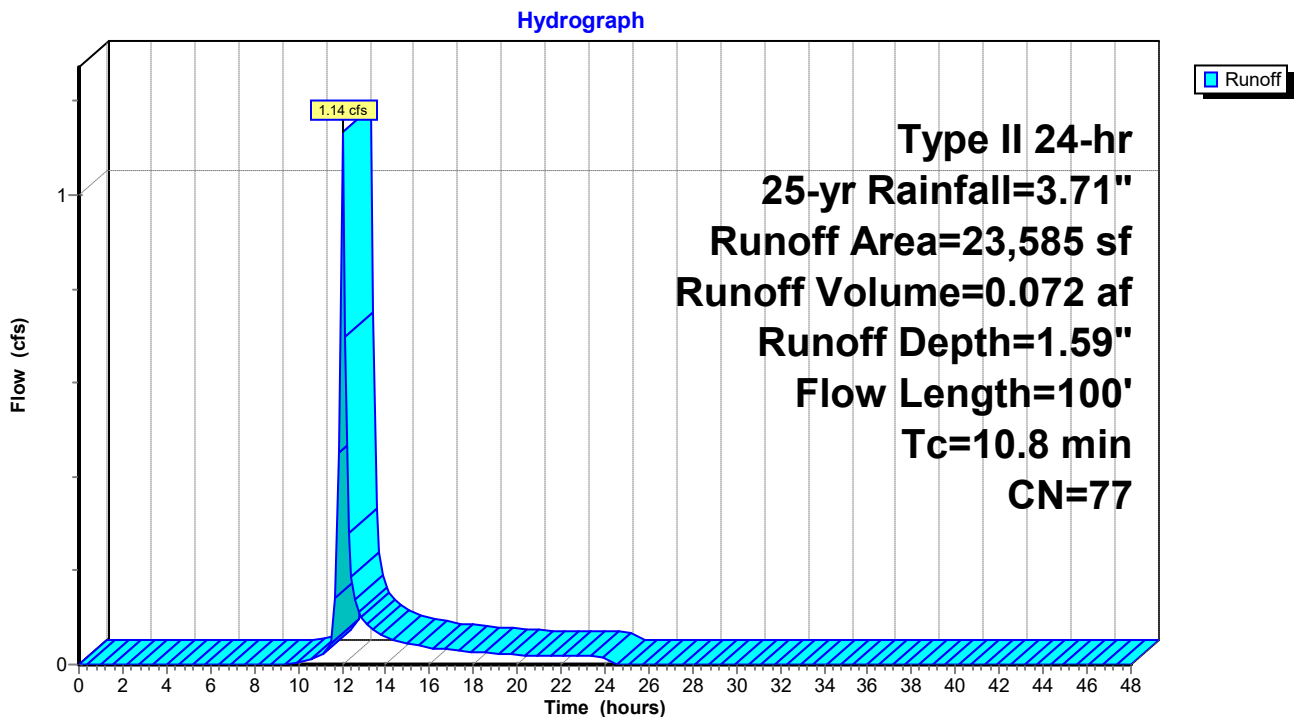

Plug Power - Proposed Conditions 5-15-21

Type II 24-hr 25-yr Rainfall=3.71"

Prepared by {enter your company name here}

Printed 5/20/2021

HydroCAD® 10.10-5a s/n 11585 © 2020 HydroCAD Software Solutions LLC

Page 195

Summary for Subcatchment 58S: Area Overland to North Prop. Line and Wetland Ditch (West)

Runoff = 0.68 cfs @ 12.08 hrs, Volume= 0.052 af, Depth= 1.59"

Runoff by SCS TR-20 method, UH=SCS, Weighted-CN, Time Span= 0.00-48.00 hrs, dt= 0.15 hrs
Type II 24-hr 25-yr Rainfall=3.71"

Area (sf)	CN	Description
17,005	77	Brush, Fair, HSG D
17,005		100.00% Pervious Area

Tc (min)	Length (feet)	Slope (ft/ft)	Velocity (ft/sec)	Capacity (cfs)	Description
14.1	100	0.0100	0.12		Sheet Flow, 100' Overland Flow Range n= 0.130 P2= 2.14"
0.8	70	0.0400	1.40		Shallow Concentrated Flow, 70' Shallow Conc. Flow Short Grass Pasture Kv= 7.0 fps
14.9	170	Total			

Subcatchment 58S: Area Overland to North Prop. Line and Wetland Ditch (West)

Hydrograph

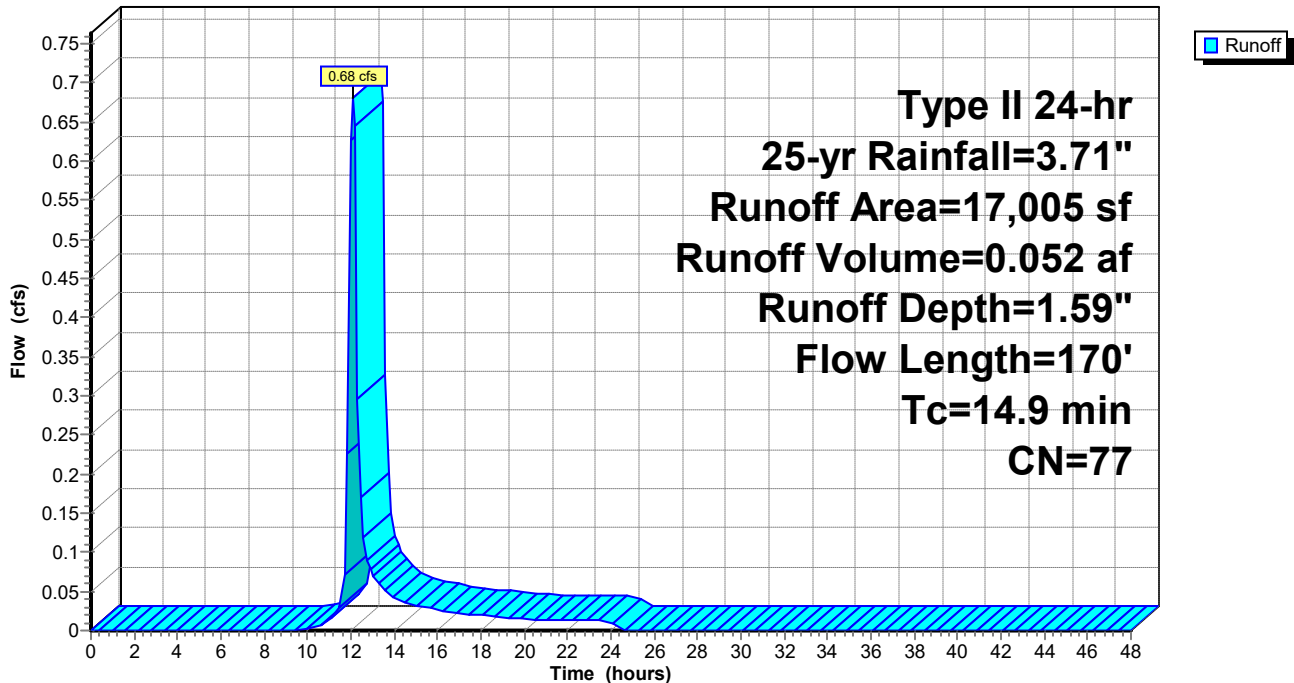

Plug Power - Proposed Conditions 5-15-21

Type II 24-hr 25-yr Rainfall=3.71"

Prepared by {enter your company name here}

Printed 5/20/2021

HydroCAD® 10.10-5a s/n 11585 © 2020 HydroCAD Software Solutions LLC

Page 196

Summary for Reach 7R: Crosby Road Ditch

Inflow Area = 0.230 ac, 0.00% Impervious, Inflow Depth = 1.73" for 25-yr event
Inflow = 0.39 cfs @ 12.18 hrs, Volume= 0.033 af
Outflow = 0.34 cfs @ 12.28 hrs, Volume= 0.033 af, Atten= 11%, Lag= 6.4 min

Routing by Dyn-Stor-Ind method, Time Span= 0.00-48.00 hrs, dt= 0.15 hrs
Max. Velocity= 1.05 fps, Min. Travel Time= 7.1 min
Avg. Velocity = 0.39 fps, Avg. Travel Time= 19.3 min

Peak Storage= 147 cf @ 12.28 hrs
Average Depth at Peak Storage= 0.13' , Surface Width= 3.04'
Bank-Full Depth= 2.00' Flow Area= 20.0 sf, Capacity= 98.41 cfs

2.00' x 2.00' deep channel, n= 0.030
Side Slope Z-value= 4.0 '/' Top Width= 18.00'
Length= 450.0' Slope= 0.0089 '/'
Inlet Invert= 673.00', Outlet Invert= 669.00'

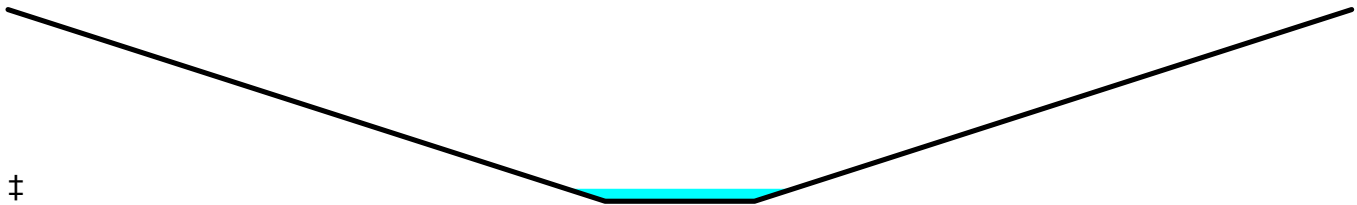

Reach 7R: Crosby Road Ditch

Hydrograph

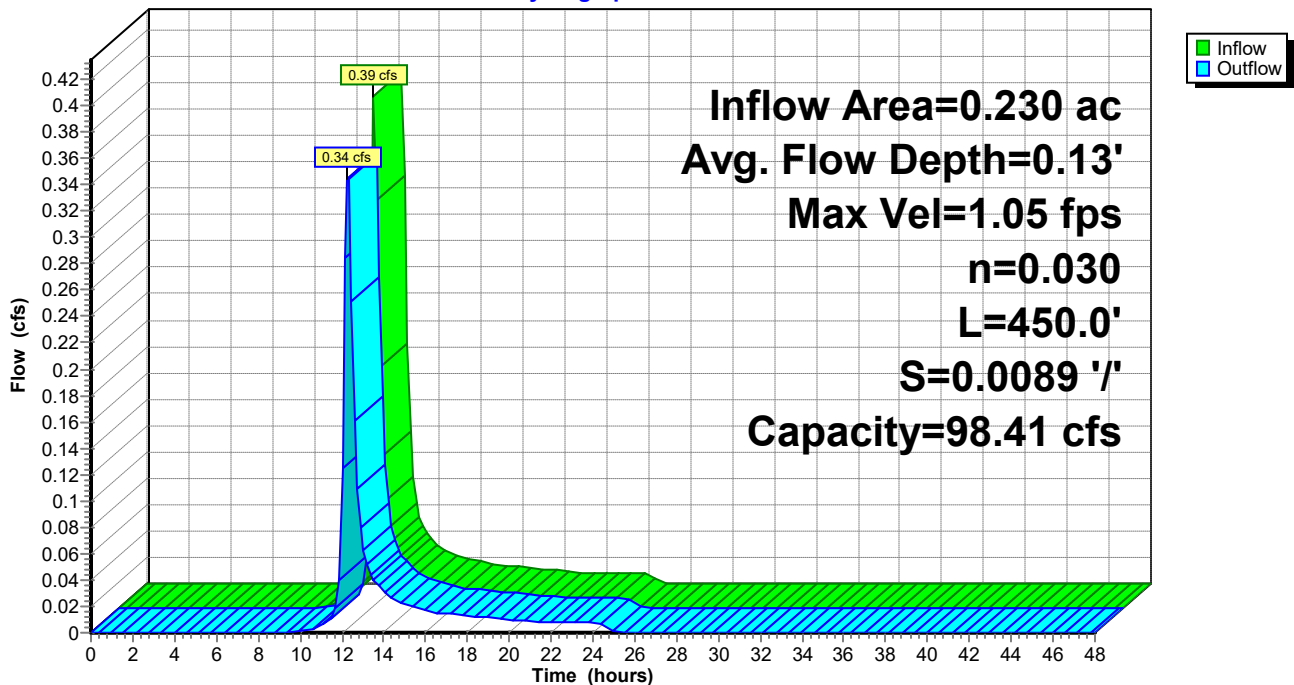

Plug Power - Proposed Conditions 5-15-21

Type II 24-hr 25-yr Rainfall=3.71"

Prepared by {enter your company name here}

Printed 5/20/2021

HydroCAD® 10.10-5a s/n 11585 © 2020 HydroCAD Software Solutions LLC

Page 197

Summary for Reach 9R: North Property Line Ditch (East)

Inflow Area = 1.403 ac, 0.00% Impervious, Inflow Depth = 1.61" for 25-yr event
Inflow = 2.51 cfs @ 12.04 hrs, Volume= 0.188 af
Outflow = 2.11 cfs @ 12.15 hrs, Volume= 0.188 af, Atten= 16%, Lag= 7.0 min

Routing by Dyn-Stor-Ind method, Time Span= 0.00-48.00 hrs, dt= 0.15 hrs
Max. Velocity= 1.56 fps, Min. Travel Time= 7.1 min
Avg. Velocity = 0.61 fps, Avg. Travel Time= 18.2 min

Peak Storage= 906 cf @ 12.15 hrs
Average Depth at Peak Storage= 0.28' , Surface Width= 7.62'
Bank-Full Depth= 3.00' Flow Area= 96.0 sf, Capacity= 634.40 cfs

2.00' x 3.00' deep channel, n= 0.030 Earth, grassed & winding
Side Slope Z-value= 10.0 ' / ' Top Width= 62.00'
Length= 670.0' Slope= 0.0100 ' / '
Inlet Invert= 669.00', Outlet Invert= 662.30'

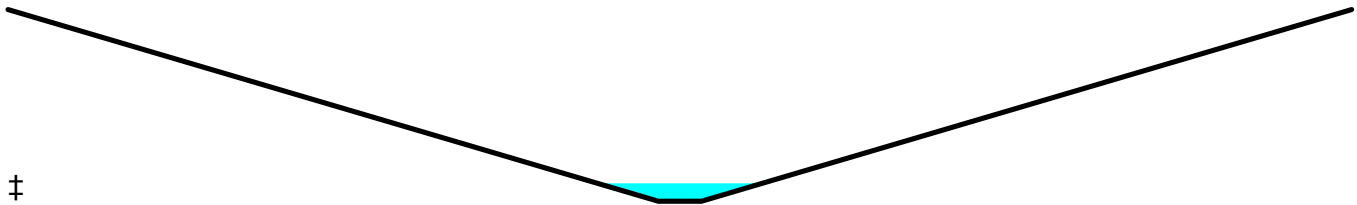

Reach 9R: North Property Line Ditch (East)

Hydrograph

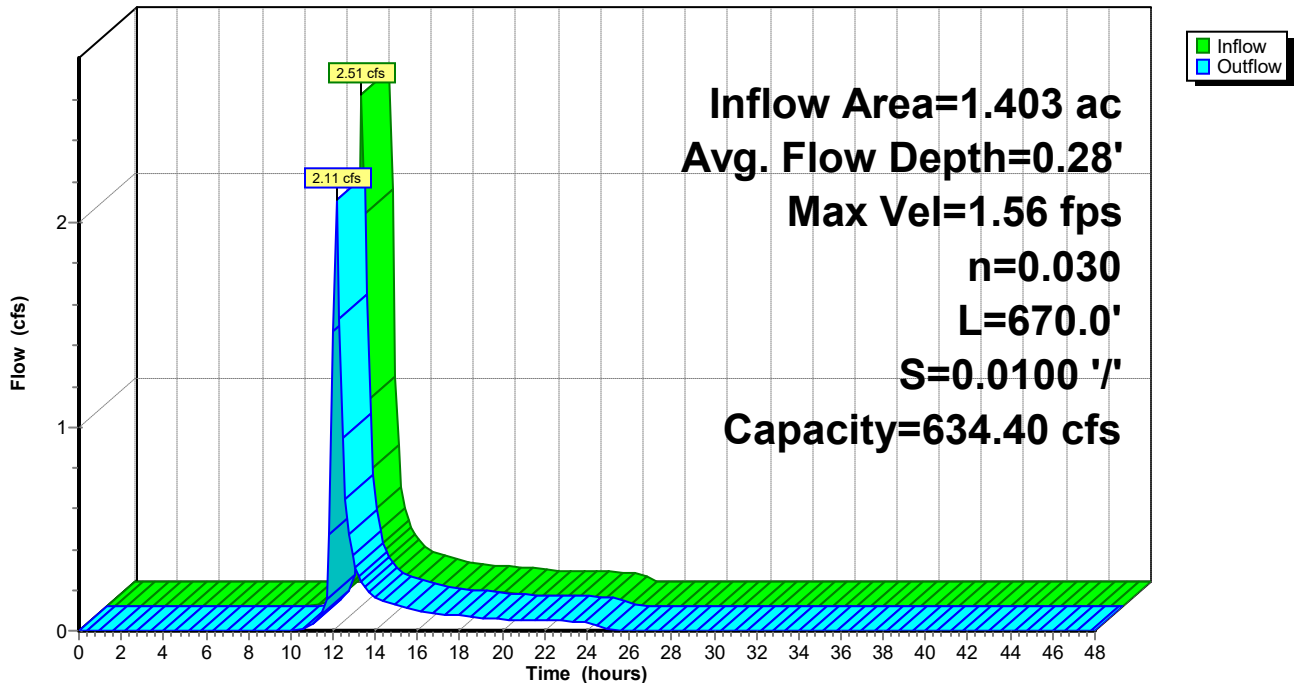

Plug Power - Proposed Conditions 5-15-21

Type II 24-hr 25-yr Rainfall=3.71"

Prepared by {enter your company name here}

Printed 5/20/2021

HydroCAD® 10.10-5a s/n 11585 © 2020 HydroCAD Software Solutions LLC

Page 198

Summary for Reach 23R: North Swale to Bio-Retention Area

Inflow Area = 0.139 ac, 0.00% Impervious, Inflow Depth =161.23" for 25-yr event
Inflow = 11.25 cfs @ 12.10 hrs, Volume= 1.863 af
Outflow = 10.83 cfs @ 12.21 hrs, Volume= 1.863 af, Atten= 4%, Lag= 6.5 min

Routing by Dyn-Stor-Ind method, Time Span= 0.00-48.00 hrs, dt= 0.15 hrs
Max. Velocity= 0.40 fps, Min. Travel Time= 7.5 min
Avg. Velocity = 0.12 fps, Avg. Travel Time= 24.5 min

Peak Storage= 4,826 cf @ 12.21 hrs
Average Depth at Peak Storage= 2.14' , Surface Width= 21.10'
Bank-Full Depth= 3.00' Flow Area= 48.0 sf, Capacity= 23.67 cfs

4.00' x 3.00' deep channel, n= 0.300
Side Slope Z-value= 4.0 '/' Top Width= 28.00'
Length= 180.0' Slope= 0.0050 '/'
Inlet Invert= 663.90', Outlet Invert= 663.00'



Reach 23R: North Swale to Bio-Retention Area

Hydrograph

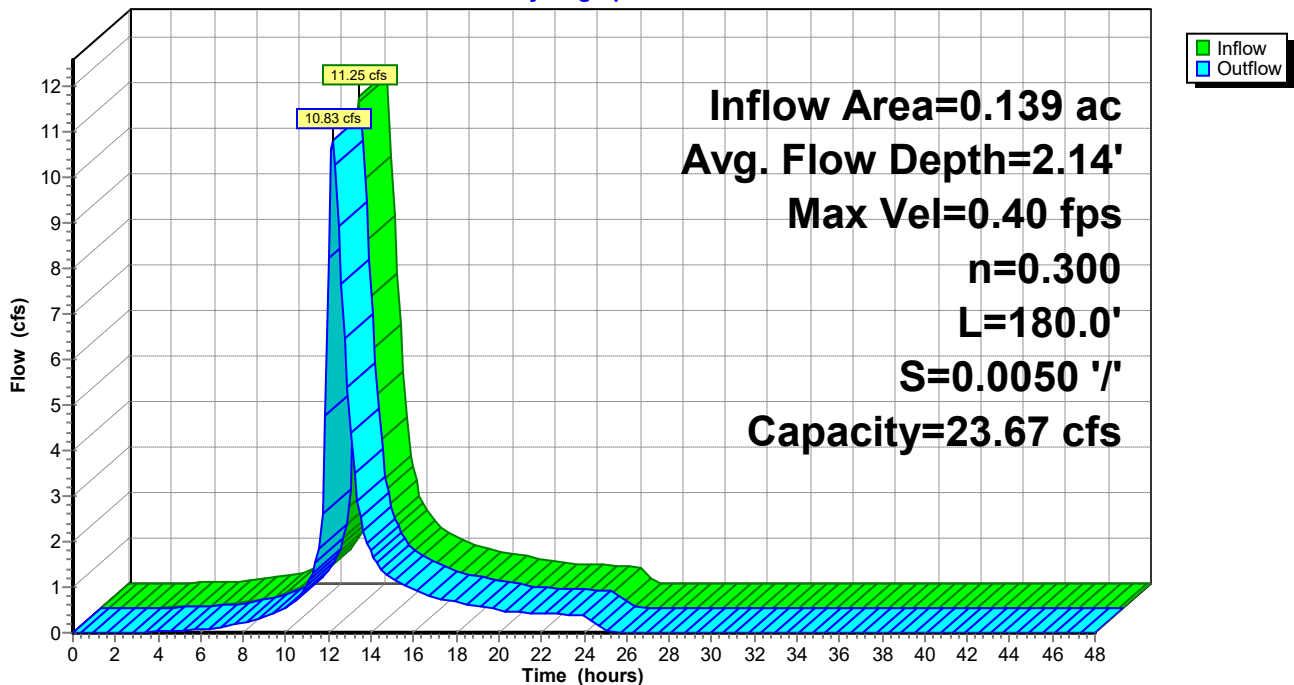

Plug Power - Proposed Conditions 5-15-21

Type II 24-hr 25-yr Rainfall=3.71"

Prepared by {enter your company name here}

Printed 5/20/2021

HydroCAD® 10.10-5a s/n 11585 © 2020 HydroCAD Software Solutions LLC

Page 199

Summary for Reach 25R: North Property Line Ditch (Central0)

Inflow Area = 2.689 ac, 0.00% Impervious, Inflow Depth = 4.16" for 25-yr event
Inflow = 4.88 cfs @ 12.21 hrs, Volume= 0.932 af
Outflow = 4.65 cfs @ 12.34 hrs, Volume= 0.932 af, Atten= 5%, Lag= 8.0 min

Routing by Dyn-Stor-Ind method, Time Span= 0.00-48.00 hrs, dt= 0.15 hrs
Max. Velocity= 1.36 fps, Min. Travel Time= 6.1 min
Avg. Velocity = 0.50 fps, Avg. Travel Time= 16.7 min

Peak Storage= 1,708 cf @ 12.34 hrs
Average Depth at Peak Storage= 0.49' , Surface Width= 11.86'
Bank-Full Depth= 3.00' Flow Area= 96.0 sf, Capacity= 401.23 cfs

2.00' x 3.00' deep channel, n= 0.030 Earth, grassed & winding
Side Slope Z-value= 10.0 ' / ' Top Width= 62.00'
Length= 500.0' Slope= 0.0040 ' / '
Inlet Invert= 662.30', Outlet Invert= 660.30'

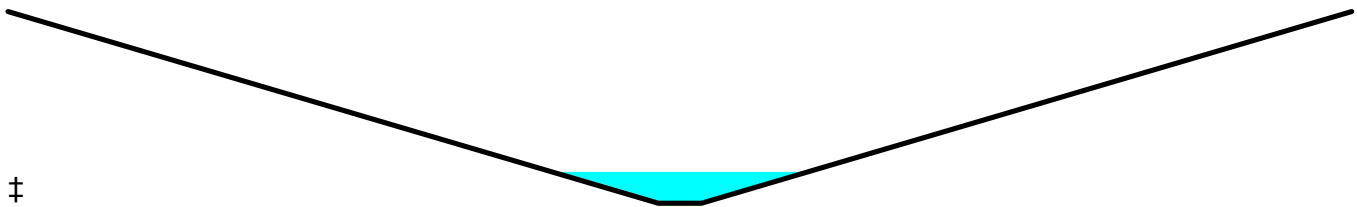

Reach 25R: North Property Line Ditch (Central0)

Hydrograph

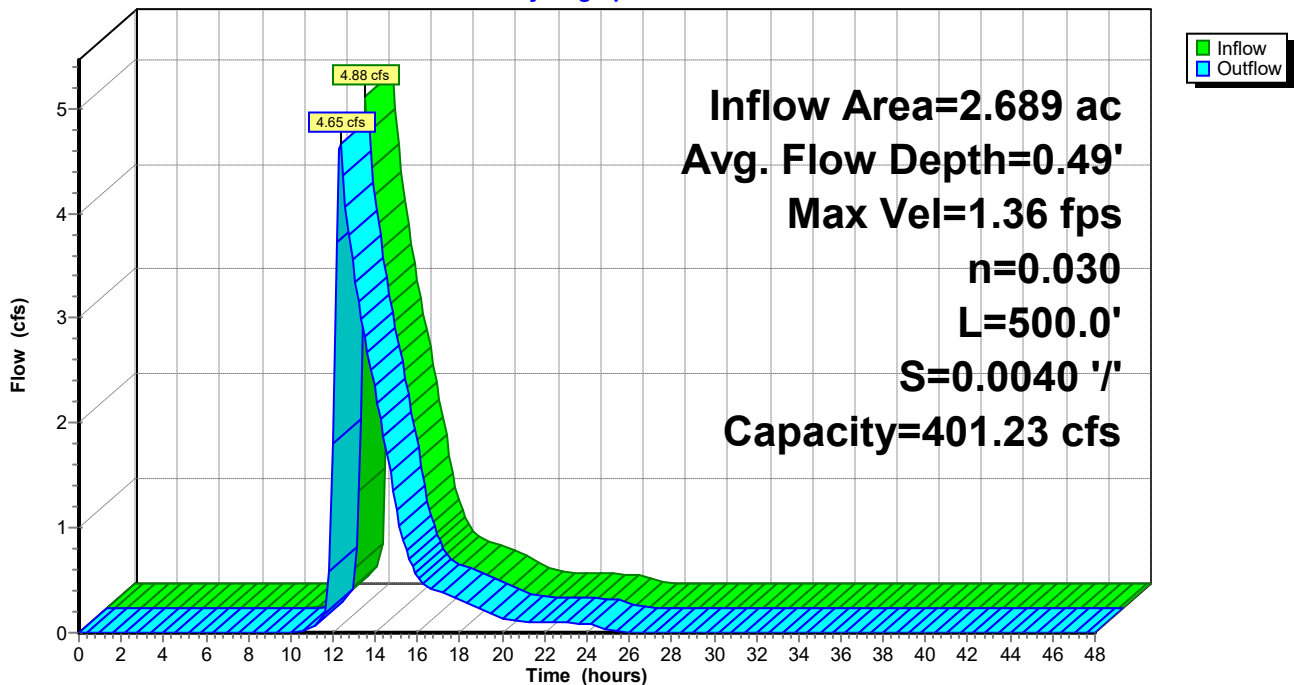

Plug Power - Proposed Conditions 5-15-21

Type II 24-hr 25-yr Rainfall=3.71"

Prepared by {enter your company name here}

Printed 5/20/2021

HydroCAD® 10.10-5a s/n 11585 © 2020 HydroCAD Software Solutions LLC

Page 200

Summary for Reach 26R: North Property Line Ditch (West)

Inflow Area = 27.347 ac, 45.74% Impervious, Inflow Depth = 2.48" for 25-yr event
Inflow = 18.61 cfs @ 12.75 hrs, Volume= 5.652 af
Outflow = 18.60 cfs @ 12.81 hrs, Volume= 5.652 af, Atten= 0%, Lag= 4.1 min

Routing by Dyn-Stor-Ind method, Time Span= 0.00-48.00 hrs, dt= 0.15 hrs
Max. Velocity= 1.60 fps, Min. Travel Time= 5.2 min
Avg. Velocity = 0.69 fps, Avg. Travel Time= 12.0 min

Peak Storage= 5,818 cf @ 12.81 hrs
Average Depth at Peak Storage= 0.98' , Surface Width= 21.67'
Bank-Full Depth= 3.00' Flow Area= 96.0 sf, Capacity= 310.79 cfs

2.00' x 3.00' deep channel, n= 0.030 Earth, grassed & winding
Side Slope Z-value= 10.0 ' / ' Top Width= 62.00'
Length= 500.0' Slope= 0.0024 ' / '
Inlet Invert= 660.30', Outlet Invert= 659.10'

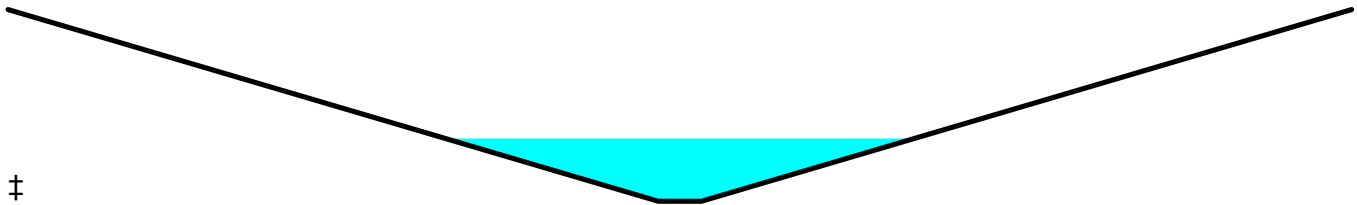

Reach 26R: North Property Line Ditch (West)

Hydrograph

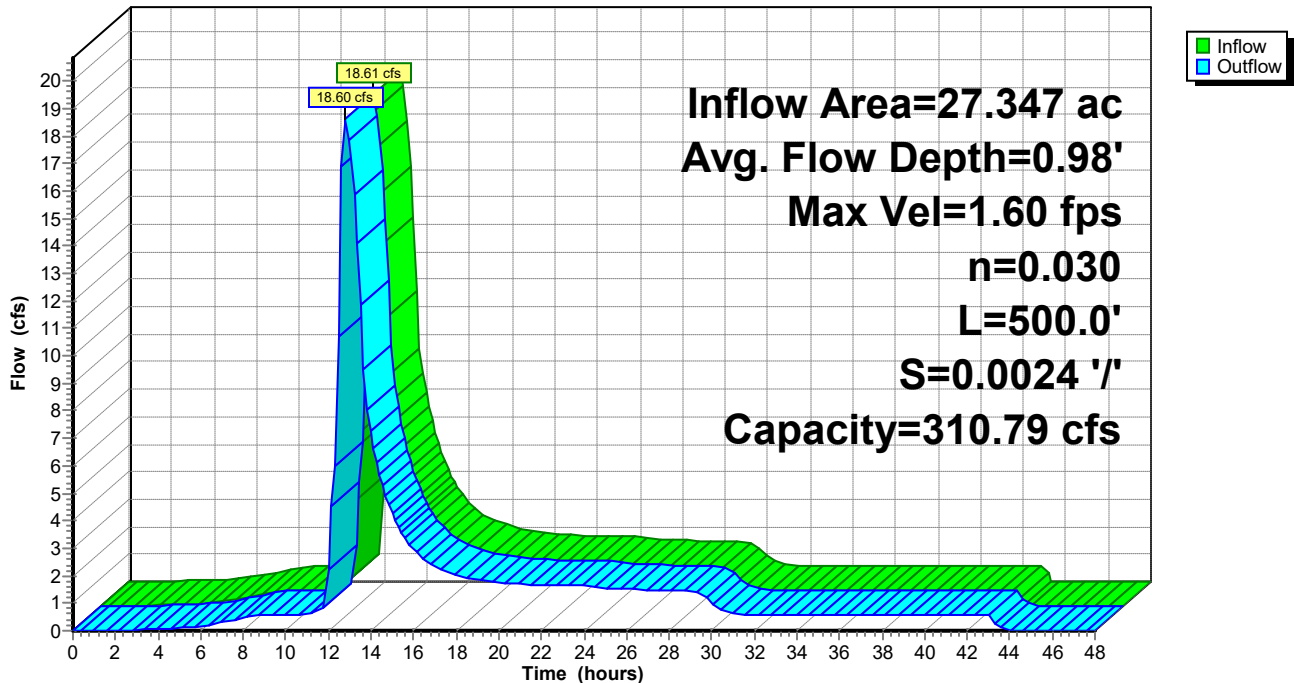

Plug Power - Proposed Conditions 5-15-21

Type II 24-hr 25-yr Rainfall=3.71"

Prepared by {enter your company name here}

Printed 5/20/2021

HydroCAD® 10.10-5a s/n 11585 © 2020 HydroCAD Software Solutions LLC

Page 201

Summary for Reach 27R: Swale to Dry Pond

Inflow Area = 0.303 ac, 0.00% Impervious, Inflow Depth = 23.96" for 25-yr event
Inflow = 17.15 cfs @ 12.18 hrs, Volume= 0.606 af
Outflow = 17.14 cfs @ 12.19 hrs, Volume= 0.606 af, Atten= 0%, Lag= 0.7 min

Routing by Dyn-Stor-Ind method, Time Span= 0.00-48.00 hrs, dt= 0.15 hrs
Max. Velocity= 2.25 fps, Min. Travel Time= 1.0 min
Avg. Velocity = 0.35 fps, Avg. Travel Time= 6.2 min

Peak Storage= 989 cf @ 12.19 hrs
Average Depth at Peak Storage= 0.84' , Surface Width= 14.14'
Bank-Full Depth= 2.00' Flow Area= 32.0 sf, Capacity= 118.87 cfs

A factor of 2.00 has been applied to the storage and discharge capacity
2.00' x 2.00' deep channel, n= 0.030
Side Slope Z-value= 3.0 '/' Top Width= 14.00'
Length= 130.0' Slope= 0.0050 '/'
Inlet Invert= 665.85', Outlet Invert= 665.20'



Reach 27R: Swale to Dry Pond

Hydrograph

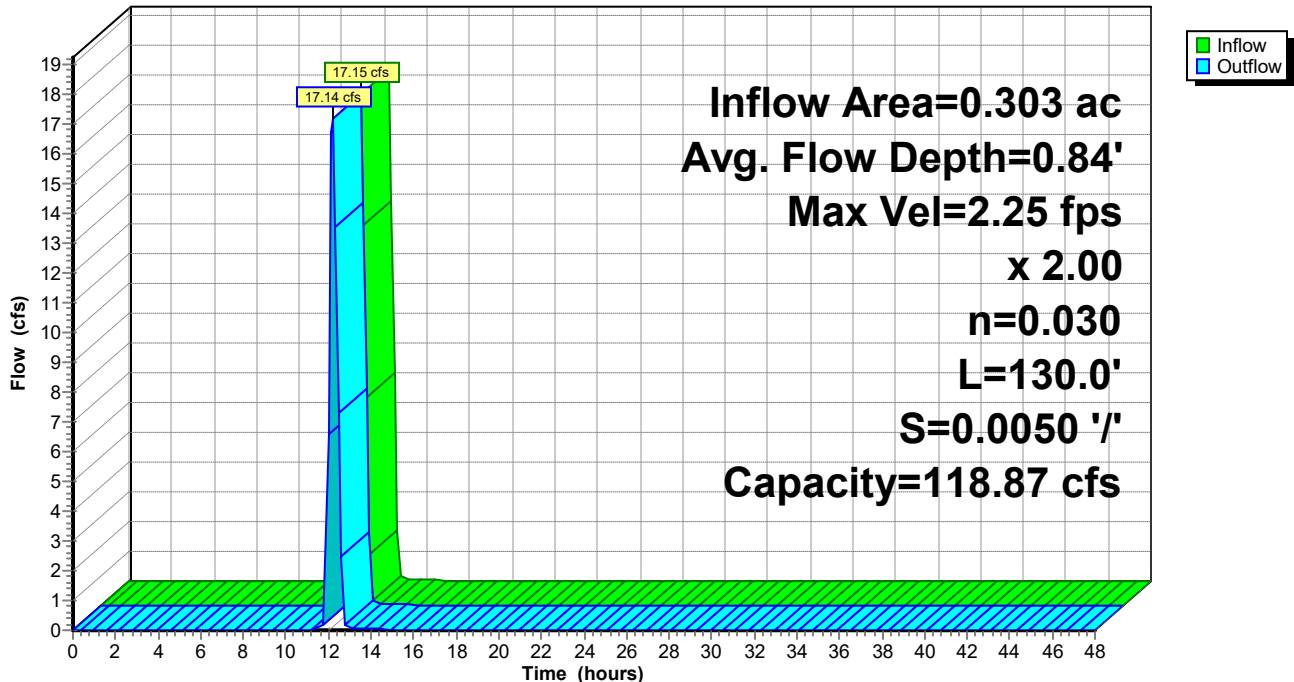

Plug Power - Proposed Conditions 5-15-21

Type II 24-hr 25-yr Rainfall=3.71"

Prepared by {enter your company name here}

Printed 5/20/2021

HydroCAD® 10.10-5a s/n 11585 © 2020 HydroCAD Software Solutions LLC

Page 202

Summary for Reach 52R: West Swale to Bio-Retention Area

Inflow Area = 22.492 ac, 55.62% Impervious, Inflow Depth = 1.36" for 25-yr event
Inflow = 18.52 cfs @ 12.08 hrs, Volume= 2.558 af
Outflow = 17.84 cfs @ 12.17 hrs, Volume= 2.558 af, Atten= 4%, Lag= 5.2 min

Routing by Dyn-Stor-Ind method, Time Span= 0.00-48.00 hrs, dt= 0.15 hrs
Max. Velocity= 0.46 fps, Min. Travel Time= 6.5 min
Avg. Velocity = 0.13 fps, Avg. Travel Time= 22.7 min

Peak Storage= 6,998 cf @ 12.17 hrs
Average Depth at Peak Storage= 2.66' , Surface Width= 25.26'
Bank-Full Depth= 3.00' Flow Area= 48.0 sf, Capacity= 23.67 cfs

4.00' x 3.00' deep channel, n= 0.300
Side Slope Z-value= 4.0 '/' Top Width= 28.00'
Length= 180.0' Slope= 0.0050 '/'
Inlet Invert= 663.90', Outlet Invert= 663.00'



Reach 52R: West Swale to Bio-Retention Area

Hydrograph

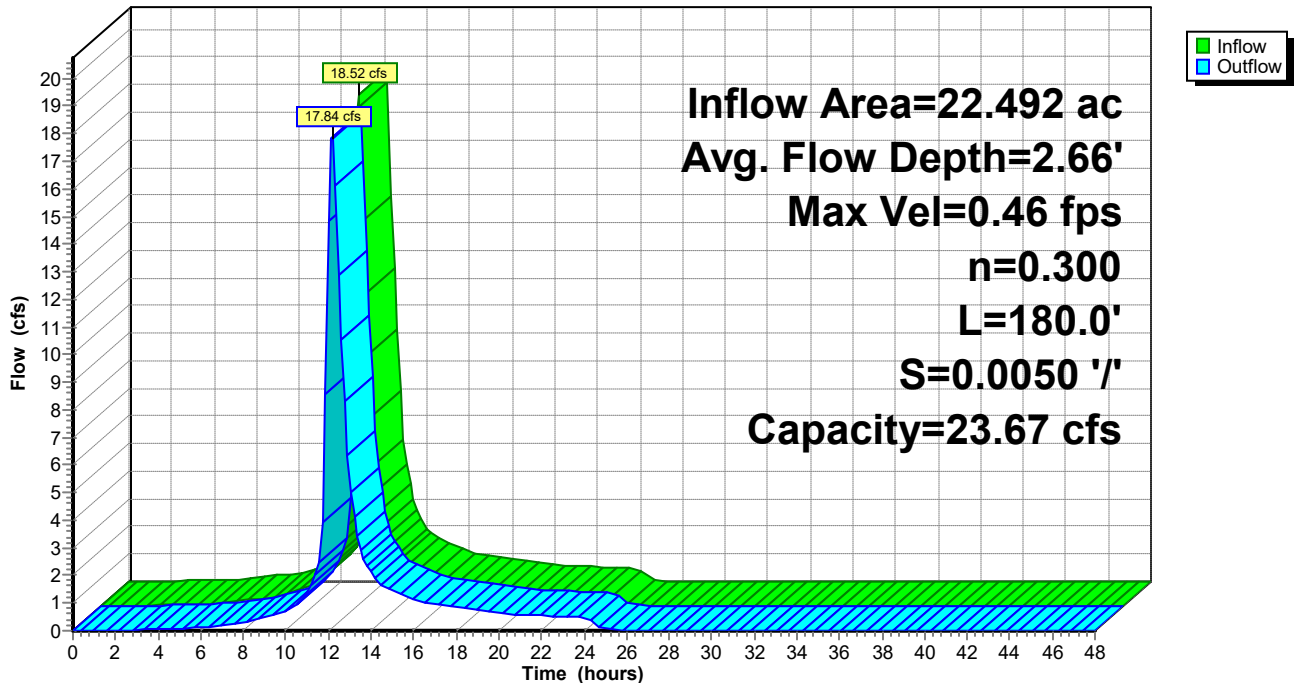

Plug Power - Proposed Conditions 5-15-21

Type II 24-hr 25-yr Rainfall=3.71"

Prepared by {enter your company name here}

Printed 5/20/2021

HydroCAD® 10.10-5a s/n 11585 © 2020 HydroCAD Software Solutions LLC

Page 203

Summary for Pond 11P: CB#1

Inflow Area = 0.442 ac, 67.06% Impervious, Inflow Depth = 2.84" for 25-yr event
Inflow = 1.50 cfs @ 12.02 hrs, Volume= 0.104 af
Outflow = 1.50 cfs @ 12.02 hrs, Volume= 0.104 af, Atten= 0%, Lag= 0.0 min
Primary = 1.50 cfs @ 12.02 hrs, Volume= 0.104 af

Routing by Dyn-Stor-Ind method, Time Span= 0.00-48.00 hrs, dt= 0.15 hrs

Peak Elev= 668.89' @ 12.19 hrs

Flood Elev= 672.65'

Device	Routing	Invert	Outlet Devices
#1	Primary	667.41'	12.0" Round Culvert L= 137.0' CPP, square edge headwall, Ke= 0.500 Inlet / Outlet Invert= 667.41' / 667.14' S= 0.0020 '/ Cc= 0.900 n= 0.012, Flow Area= 0.79 sf

Primary OutFlow Max=0.00 cfs @ 12.02 hrs HW=668.42' TW=668.70' (Dynamic Tailwater)
↑1=Culvert (Controls 0.00 cfs)

Pond 11P: CB#1

Hydrograph

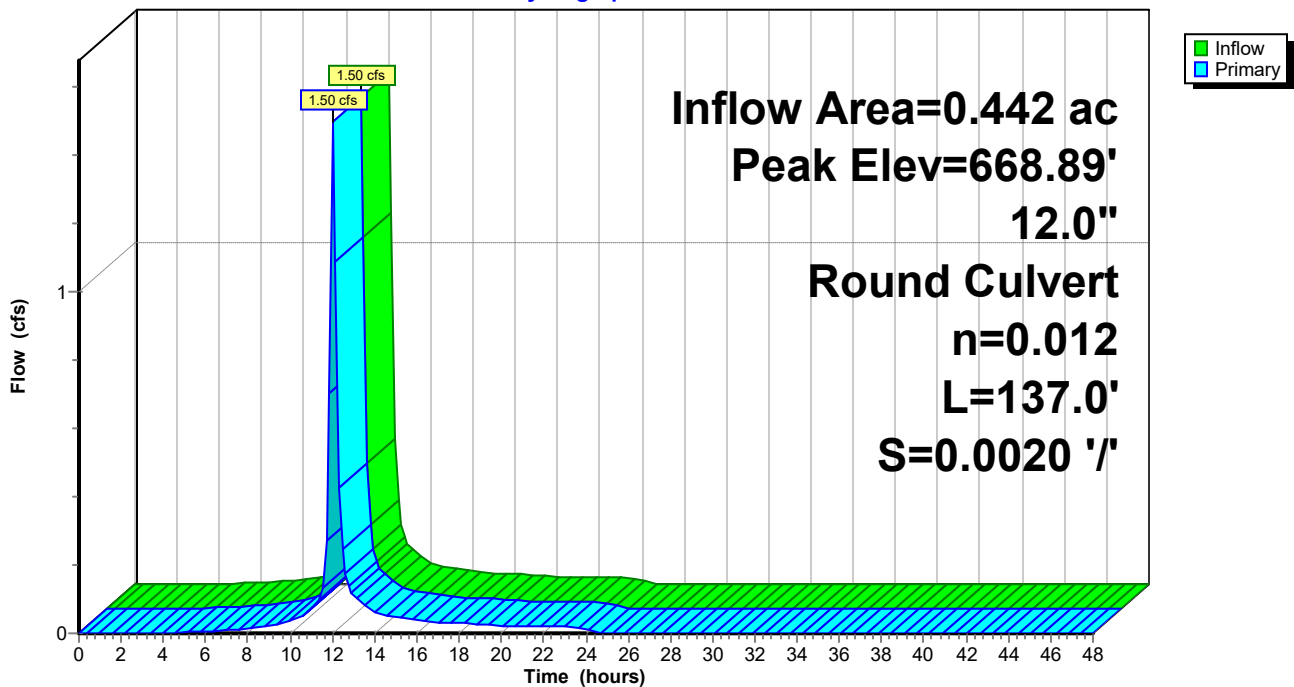

Plug Power - Proposed Conditions 5-15-21

Type II 24-hr 25-yr Rainfall=3.71"

Prepared by {enter your company name here}

Printed 5/20/2021

HydroCAD® 10.10-5a s/n 11585 © 2020 HydroCAD Software Solutions LLC

Page 204

Summary for Pond 13P: CB#3

Inflow Area = 0.724 ac, 59.47% Impervious, Inflow Depth = 2.73" for 25-yr event
Inflow = 2.37 cfs @ 12.03 hrs, Volume= 0.165 af
Outflow = 2.37 cfs @ 12.03 hrs, Volume= 0.165 af, Atten= 0%, Lag= 0.0 min
Primary = 2.37 cfs @ 12.03 hrs, Volume= 0.165 af

Routing by Dyn-Stor-Ind method, Time Span= 0.00-48.00 hrs, dt= 0.15 hrs
Peak Elev= 668.81' @ 12.07 hrs
Flood Elev= 672.65'

Device	Routing	Invert	Outlet Devices
#1	Primary	667.14'	12.0" Round Culvert L= 213.0' CPP, square edge headwall, Ke= 0.500 Inlet / Outlet Invert= 667.14' / 666.71' S= 0.0020 '/ Cc= 0.900 n= 0.012, Flow Area= 0.79 sf

Primary OutFlow Max=1.67 cfs @ 12.03 hrs HW=668.70' TW=668.20' (Dynamic Tailwater)
↑1=Culvert (Outlet Controls 1.67 cfs @ 2.12 fps)

Pond 13P: CB#3

Hydrograph

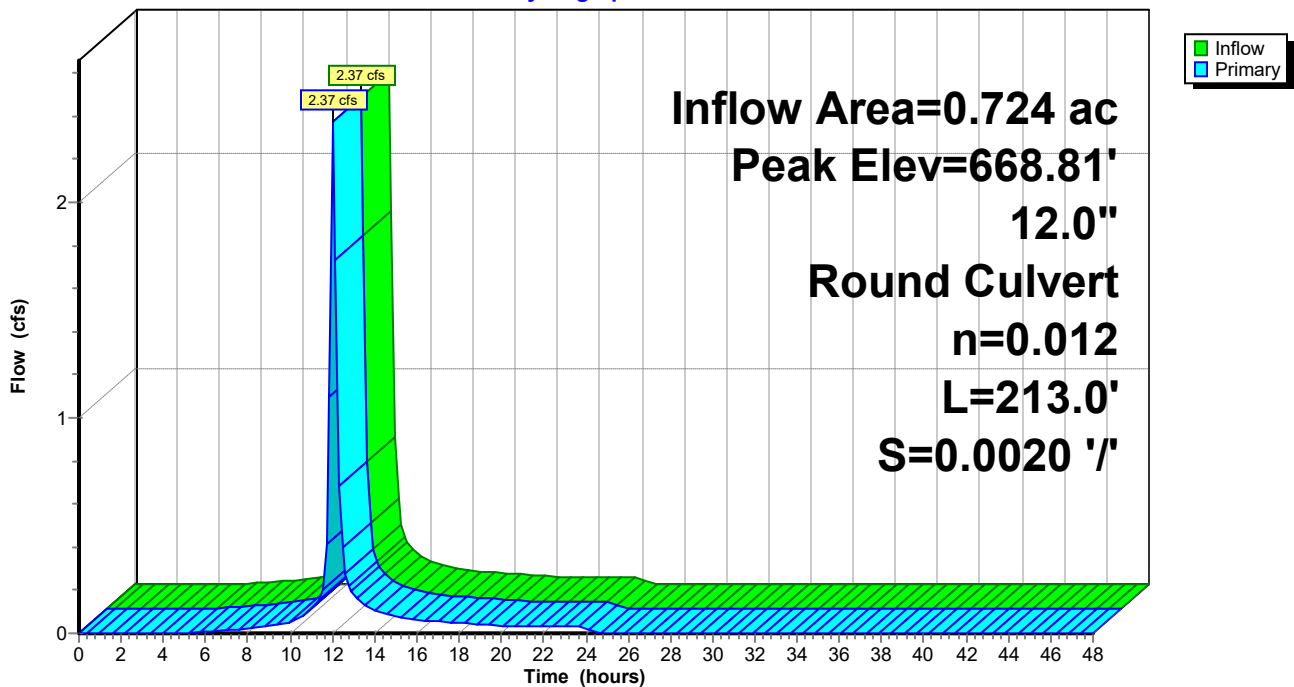

Plug Power - Proposed Conditions 5-15-21

Type II 24-hr 25-yr Rainfall=3.71"

Prepared by {enter your company name here}

Printed 5/20/2021

HydroCAD® 10.10-5a s/n 11585 © 2020 HydroCAD Software Solutions LLC

Page 205

Summary for Pond 15P: CB#5

Inflow Area = 3.805 ac, 39.15% Impervious, Inflow Depth = 2.36" for 25-yr event
Inflow = 8.42 cfs @ 12.14 hrs, Volume= 0.750 af
Outflow = 8.42 cfs @ 12.14 hrs, Volume= 0.750 af, Atten= 0%, Lag= 0.0 min
Primary = 8.42 cfs @ 12.14 hrs, Volume= 0.750 af

Routing by Dyn-Stor-Ind method, Time Span= 0.00-48.00 hrs, dt= 0.15 hrs

Peak Elev= 668.39' @ 12.15 hrs

Flood Elev= 670.95'

Device #	Routing	Invert	Outlet Devices
#1	Primary	666.71'	24.0" Round Culvert L= 180.0' CPP, square edge headwall, Ke= 0.500 Inlet / Outlet Invert= 666.71' / 666.35' S= 0.0020 '/' Cc= 0.900 n= 0.012, Flow Area= 3.14 sf

Primary OutFlow Max=8.30 cfs @ 12.14 hrs HW=668.38' TW=667.44' (Dynamic Tailwater)
↑1=Culvert (Barrel Controls 8.30 cfs @ 4.01 fps)

Pond 15P: CB#5

Hydrograph

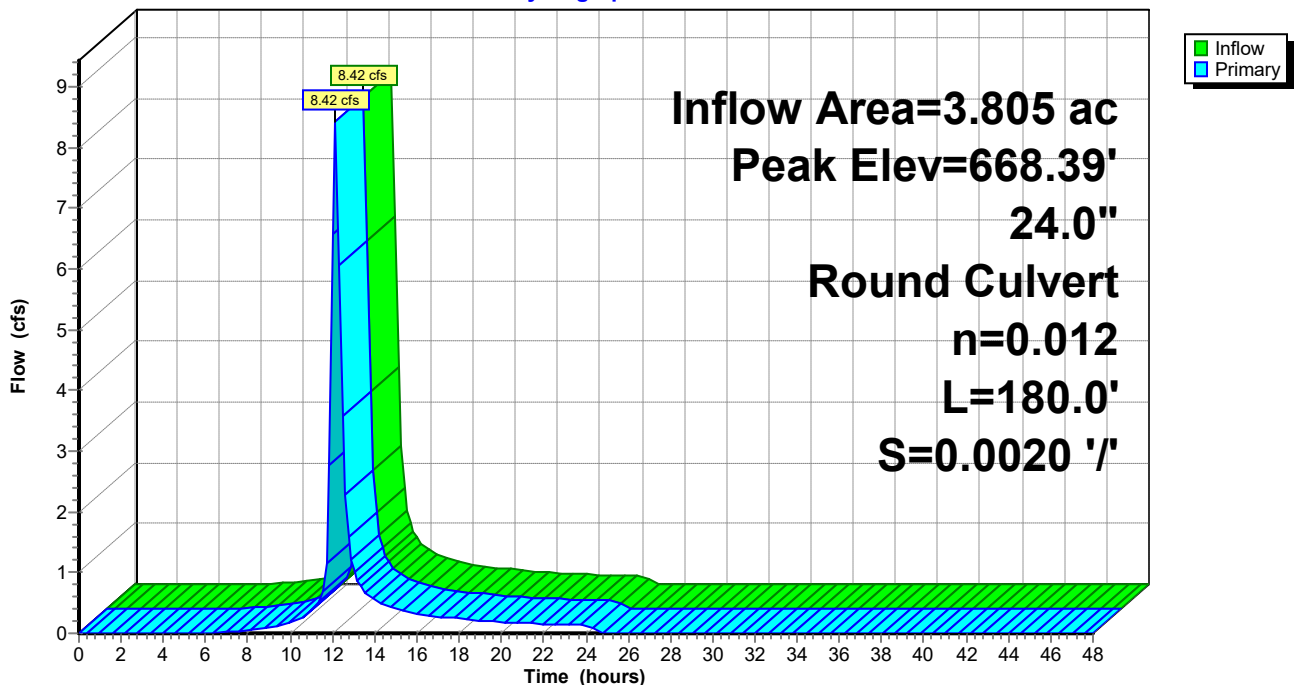

Plug Power - Proposed Conditions 5-15-21

Type II 24-hr 25-yr Rainfall=3.71"

Prepared by {enter your company name here}

Printed 5/20/2021

HydroCAD® 10.10-5a s/n 11585 © 2020 HydroCAD Software Solutions LLC

Page 206

Summary for Pond 19P: YD#22

Inflow Area = 0.624 ac, 27.67% Impervious, Inflow Depth = 1.96" for 25-yr event
 Inflow = 1.20 cfs @ 12.17 hrs, Volume= 0.102 af
 Outflow = 1.20 cfs @ 12.17 hrs, Volume= 0.102 af, Atten= 0%, Lag= 0.0 min
 Primary = 1.20 cfs @ 12.17 hrs, Volume= 0.102 af

Routing by Dyn-Stor-Ind method, Time Span= 0.00-48.00 hrs, dt= 0.15 hrs
 Peak Elev= 667.80' @ 12.18 hrs Surf.Area= 1 sf Storage= 3 cf
 Flood Elev= 669.45' Surf.Area= 17,680 sf Storage= 5,217 cf

Plug-Flow detention time= (not calculated: outflow precedes inflow)
 Center-of-Mass det. time= 0.1 min (842.4 - 842.3)

Volume	Invert	Avail.Storage	Storage Description
#1	665.26'	5,217 cf	Custom Stage Data (Prismatic) Listed below (Recalc)
Elevation (feet)	Surf.Area (sq-ft)	Inc.Store (cubic-feet)	Cum.Store (cubic-feet)
665.26	1	0	0
668.55	1	3	3
669.00	2,745	618	621
669.45	17,680	4,596	5,217

Device	Routing	Invert	Outlet Devices
#1	Primary	665.26'	10.0" Round Culvert L= 70.0' CPP, square edge headwall, Ke= 0.500 Inlet / Outlet Invert= 665.26' / 665.12' S= 0.0020 '/' Cc= 0.900 n= 0.012, Flow Area= 0.55 sf

Primary OutFlow Max=1.41 cfs @ 12.17 hrs HW=667.73' TW=667.32' (Dynamic Tailwater)
 ↑**1=Culvert** (Outlet Controls 1.41 cfs @ 2.59 fps)

Pond 19P: YD#22

Hydrograph

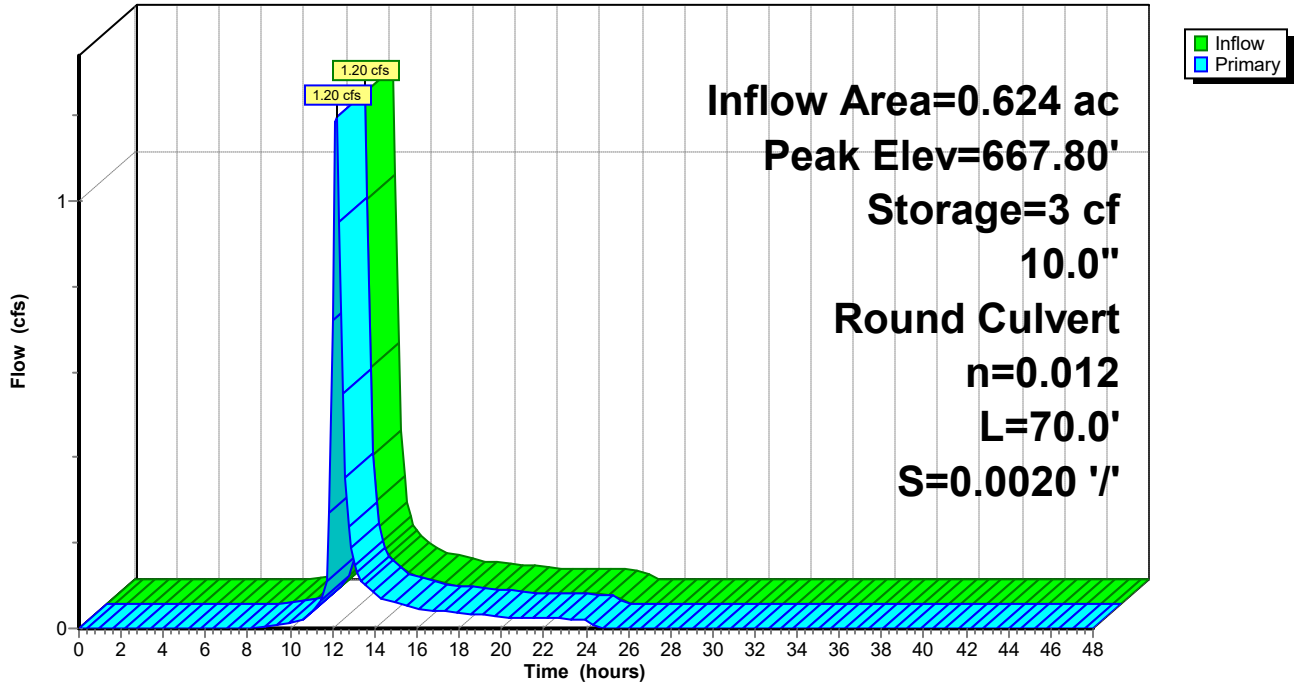

Plug Power - Proposed Conditions 5-15-21

Type II 24-hr 25-yr Rainfall=3.71"

Prepared by {enter your company name here}

Printed 5/20/2021

HydroCAD® 10.10-5a s/n 11585 © 2020 HydroCAD Software Solutions LLC

Page 208

Summary for Pond 21P: Subsurface Detention within Gravel Area

Inflow Area = 22.356 ac, 55.95% Impervious, Inflow Depth = 2.65" for 25-yr event
 Inflow = 48.11 cfs @ 12.06 hrs, Volume= 4.939 af
 Outflow = 45.73 cfs @ 12.15 hrs, Volume= 4.939 af, Atten= 5%, Lag= 5.7 min
 Primary = 18.36 cfs @ 12.09 hrs, Volume= 2.537 af
 Secondary = 11.11 cfs @ 12.11 hrs, Volume= 1.842 af
 Tertiary = 16.93 cfs @ 12.18 hrs, Volume= 0.560 af

Routing by Dyn-Stor-Ind method, Time Span= 0.00-48.00 hrs, dt= 0.15 hrs
 Peak Elev= 667.49' @ 12.18 hrs Surf.Area= 8,430 sf Storage= 10,573 cf
 Flood Elev= 668.95' Surf.Area= 129,465 sf Storage= 49,282 cf

Plug-Flow detention time= 4.2 min calculated for 4.924 af (100% of inflow)
 Center-of-Mass det. time= 4.2 min (810.4 - 806.2)

Volume	Invert	Avail.Storage	Storage Description
#1	664.01'	9,879 cf	Custom Stage Data (Prismatic) Listed below (Recalc) 30,436 cf Overall - 5,739 cf Embedded = 24,697 cf x 40.0% Voids
#2	664.01'	126 cf	24.0" Round Pipe Storage Inside #1 L= 40.0'
#3	664.01'	3,657 cf	24.0" Round Pipe Storage Inside #1 L= 1,164.0' S= 0.0020 '/'
#4	664.01'	1,421 cf	18.0" Round Pipe Storage Inside #1 L= 804.0' S= 0.0020 '/'
#5	665.61'	209 cf	15.0" Round Pipe Storage Inside #1 L= 170.0' S= 0.0020 '/'
#6	665.95'	202 cf	12.0" Round Pipe Storage Inside #1 L= 257.0' S= 0.0020 '/'
#7	666.46'	38 cf	10.0" Round Pipe Storage Inside #1 L= 69.0' S= 0.0020 '/'
#8	666.35'	88 cf	10.0" Round Pipe Storage Inside #1 L= 161.0' S= 0.0020 '/'
#9	668.02'	33,664 cf	Custom Stage Data (Prismatic) Listed below (Recalc) 84,161 cf Overall x 40.0% Voids
		49,282 cf	Total Available Storage

Elevation (feet)	Surf.Area (sq-ft)	Inc.Store (cubic-feet)	Cum.Store (cubic-feet)
664.01	3	0	0
666.67	8,430	11,216	11,216
668.95	8,430	19,220	30,436

Elevation (feet)	Surf.Area (sq-ft)	Inc.Store (cubic-feet)	Cum.Store (cubic-feet)
668.02	0	0	0
668.18	33,970	2,718	2,718
668.45	121,035	20,926	23,643
668.95	121,035	60,518	84,161

Plug Power - Proposed Conditions 5-15-21

Type II 24-hr 25-yr Rainfall=3.71"

Prepared by {enter your company name here}

Printed 5/20/2021

HydroCAD® 10.10-5a s/n 11585 © 2020 HydroCAD Software Solutions LLC

Page 209

Device	Routing	Invert	Outlet Devices
#1	Primary	664.01'	18.0" Round Culvert X 2.00 L= 57.0' CPP, square edge headwall, Ke= 0.500 Inlet / Outlet Invert= 664.01' / 663.90' S= 0.0019' / Cc= 0.900 n= 0.012, Flow Area= 1.77 sf
#2	Secondary	664.01'	18.0" Round Culvert L= 57.0' CPP, square edge headwall, Ke= 0.500 Inlet / Outlet Invert= 664.01' / 663.90' S= 0.0019' / Cc= 0.900 n= 0.012, Flow Area= 1.77 sf
#3	Tertiary	665.95'	18.0" Round Culvert X 3.00 L= 50.0' CPP, square edge headwall, Ke= 0.500 Inlet / Outlet Invert= 665.95' / 665.85' S= 0.0020' / Cc= 0.900 n= 0.012, Flow Area= 1.77 sf

Primary OutFlow Max=14.92 cfs @ 12.09 hrs HW=667.25' TW=666.48' (Dynamic Tailwater)

←1=Culvert (Inlet Controls 14.92 cfs @ 4.22 fps)

Secondary OutFlow Max=9.95 cfs @ 12.11 hrs HW=667.33' TW=665.96' (Dynamic Tailwater)

←2=Culvert (Inlet Controls 9.95 cfs @ 5.63 fps)

Tertiary OutFlow Max=15.87 cfs @ 12.18 hrs HW=667.43' TW=666.66' (Dynamic Tailwater)

←3=Culvert (Barrel Controls 15.87 cfs @ 3.78 fps)

Pond 21P: Subsurface Detention within Gravel Area

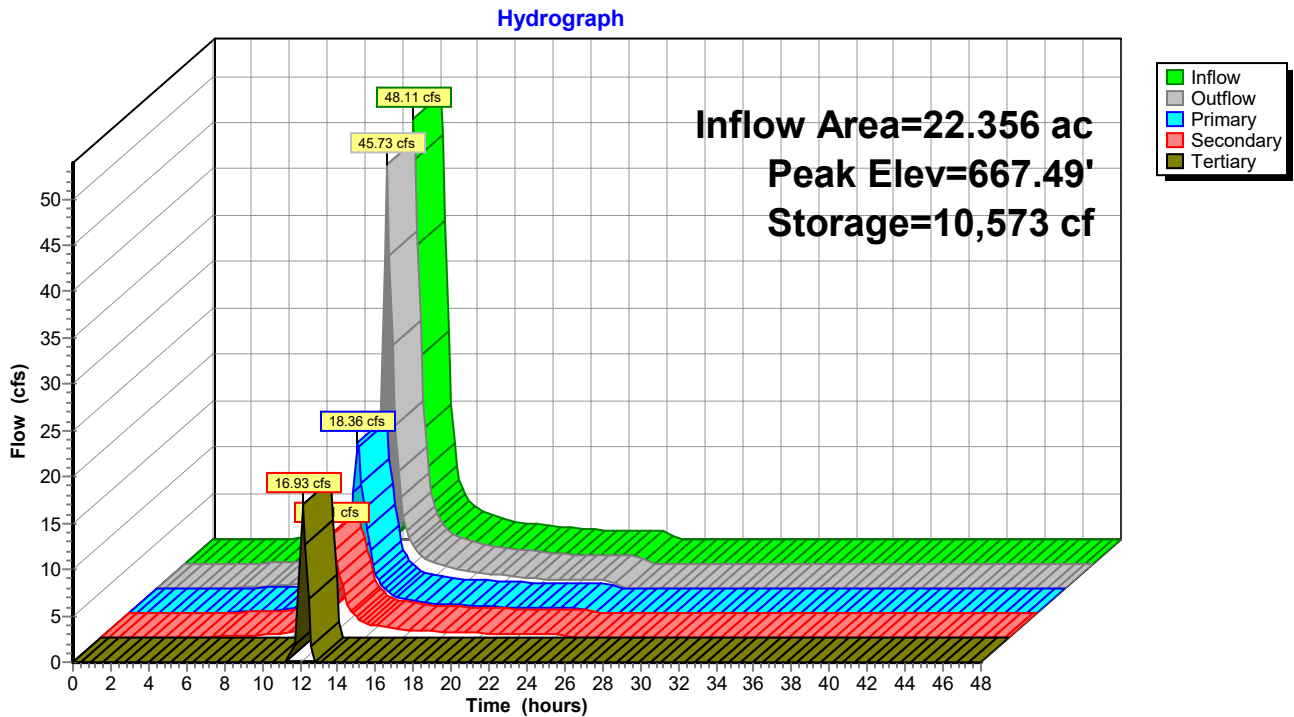

Plug Power - Proposed Conditions 5-15-21

Type II 24-hr 25-yr Rainfall=3.71"

Prepared by {enter your company name here}

Printed 5/20/2021

HydroCAD® 10.10-5a s/n 11585 © 2020 HydroCAD Software Solutions LLC

Page 210

Summary for Pond 22P: Bio-Retention Area

Inflow Area = 24.268 ac, 51.54% Impervious, Inflow Depth = 2.31" for 25-yr event
 Inflow = 29.47 cfs @ 12.15 hrs, Volume= 4.667 af
 Outflow = 14.75 cfs @ 12.78 hrs, Volume= 4.669 af, Atten= 50%, Lag= 38.2 min
 Primary = 14.75 cfs @ 12.78 hrs, Volume= 4.669 af
 Secondary = 0.00 cfs @ 0.00 hrs, Volume= 0.000 af

Routing by Dyn-Stor-Ind method, Time Span= 0.00-48.00 hrs, dt= 0.15 hrs
 Peak Elev= 664.44' @ 12.78 hrs Surf.Area= 58,893 sf Storage= 77,167 cf

Plug-Flow detention time= 363.3 min calculated for 4.654 af (100% of inflow)
 Center-of-Mass det. time= 365.7 min (1,197.3 - 831.6)

Volume	Invert	Avail.Storage	Storage Description
#1	663.00'	95,677 cf	Custom Stage Data (Prismatic) Listed below (Recalc)
Elevation (feet)	Surf.Area (sq-ft)	Inc.Store (cubic-feet)	Cum.Store (cubic-feet)
663.00	48,935	0	0
663.25	50,025	12,370	12,370
663.50	51,115	12,643	25,013
664.00	56,110	26,806	51,819
664.75	60,845	43,858	95,677

Device	Routing	Invert	Outlet Devices
#1	Primary	660.55'	15.0" Round Culvert L= 25.0' CPP, square edge headwall, Ke= 0.500 Inlet / Outlet Invert= 660.55' / 660.50' S= 0.0020 '/' Cc= 0.900 n= 0.012, Flow Area= 1.23 sf
#2	Primary	660.55'	15.0" Round Culvert L= 25.0' CPP, square edge headwall, Ke= 0.500 Inlet / Outlet Invert= 660.55' / 660.50' S= 0.0020 '/' Cc= 0.900 n= 0.012, Flow Area= 1.23 sf
#3	Device 1	660.56'	4.0" Round Culvert L= 5.0' CPP, square edge headwall, Ke= 0.500 Inlet / Outlet Invert= 660.56' / 660.55' S= 0.0020 '/' Cc= 0.900 n= 0.012, Flow Area= 0.09 sf
#4	Device 2	660.56'	4.0" Round Culvert L= 5.0' CPP, square edge headwall, Ke= 0.500 Inlet / Outlet Invert= 660.56' / 660.55' S= 0.0020 '/' Cc= 0.900 n= 0.012, Flow Area= 0.09 sf
#5	Device 3	663.00'	0.500 in/hr Exfiltration X 0.50 over Surface area
#6	Device 4	663.00'	0.500 in/hr Exfiltration X 0.50 over Surface area
#7	Device 3	663.50'	4.0" Horiz. Orifice/Grate X 4.00 C= 0.600 Limited to weir flow at low heads
#8	Device 4	663.50'	4.0" Horiz. Orifice/Grate X 3.00 C= 0.600 Limited to weir flow at low heads
#9	Device 1	664.25'	1.4" x 4.5" Horiz. Orifice/Grate X 72.00 C= 0.600 Limited to weir flow at low heads
#10	Device 2	664.25'	1.4" x 4.5" Horiz. Orifice/Grate X 72.00 C= 0.600 Limited to weir flow at low heads
#11	Secondary	664.50'	100.0' long x 2.0' breadth Broad-Crested Rectangular Weir

Plug Power - Proposed Conditions 5-15-21

Type II 24-hr 25-yr Rainfall=3.71"

Prepared by {enter your company name here}

Printed 5/20/2021

HydroCAD® 10.10-5a s/n 11585 © 2020 HydroCAD Software Solutions LLC

Page 211

Head (feet)	0.20	0.40	0.60	0.80	1.00	1.20	1.40	1.60	1.80	2.00
	2.50	3.00	3.50							
Coef. (English)	2.54	2.61	2.61	2.60	2.66	2.70	2.77	2.89	2.88	
	2.85	3.07	3.20	3.32						

Primary OutFlow Max=14.65 cfs @ 12.78 hrs HW=664.44' TW=661.28' (Dynamic Tailwater)

- 1=Culvert (Passes 7.33 cfs of 10.50 cfs potential flow)
- 3=Culvert (Inlet Controls 0.75 cfs @ 8.56 fps)
- 5=Exfiltration (Passes < 0.34 cfs potential flow)
- 7=Orifice/Grate (Passes < 1.63 cfs potential flow)
- 9=Orifice/Grate (Orifice Controls 6.58 cfs @ 2.09 fps)
- 2=Culvert (Passes 7.33 cfs of 10.50 cfs potential flow)
- 4=Culvert (Inlet Controls 0.75 cfs @ 8.56 fps)
- 6=Exfiltration (Passes < 0.34 cfs potential flow)
- 8=Orifice/Grate (Passes < 1.22 cfs potential flow)
- 10=Orifice/Grate (Orifice Controls 6.58 cfs @ 2.09 fps)

Secondary OutFlow Max=0.00 cfs @ 0.00 hrs HW=663.00' TW=660.30' (Dynamic Tailwater)

- 11=Broad-Crested Rectangular Weir (Controls 0.00 cfs)

Pond 22P: Bio-Retention Area

Hydrograph

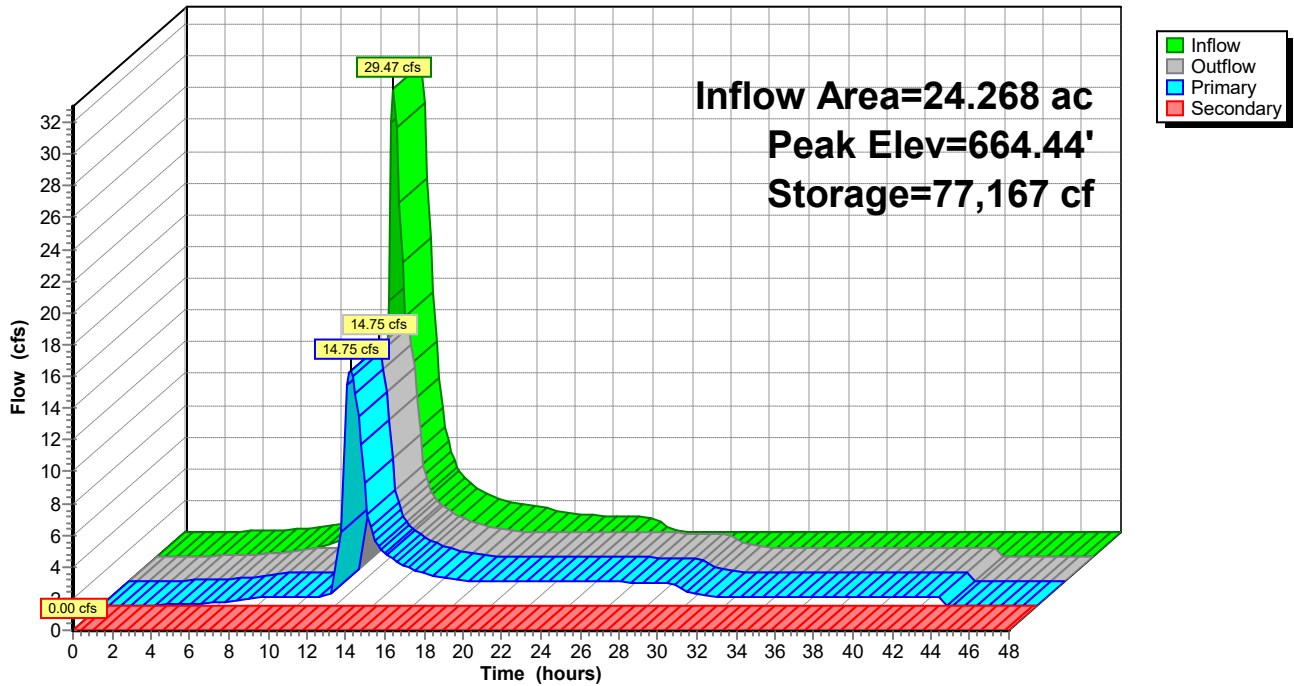

Plug Power - Proposed Conditions 5-15-21

Type II 24-hr 25-yr Rainfall=3.71"

Prepared by {enter your company name here}

Printed 5/20/2021

HydroCAD® 10.10-5a s/n 11585 © 2020 HydroCAD Software Solutions LLC

Page 212

Summary for Pond 25P: YD#11

Inflow Area = 0.893 ac, 53.89% Impervious, Inflow Depth = 2.65" for 25-yr event
 Inflow = 2.53 cfs @ 12.10 hrs, Volume= 0.197 af
 Outflow = 2.52 cfs @ 12.10 hrs, Volume= 0.197 af, Atten= 0%, Lag= 0.0 min
 Primary = 2.52 cfs @ 12.10 hrs, Volume= 0.197 af

Routing by Dyn-Stor-Ind method, Time Span= 0.00-48.00 hrs, dt= 0.15 hrs
 Peak Elev= 668.61' @ 12.18 hrs Surf.Area= 1 sf Storage= 2 cf
 Flood Elev= 669.70' Surf.Area= 3,725 sf Storage= 1,028 cf

Plug-Flow detention time= 0.0 min calculated for 0.196 af (100% of inflow)
 Center-of-Mass det. time= 0.0 min (808.7 - 808.7)

Volume	Invert	Avail.Storage	Storage Description
#1	666.25'	1,028 cf	Custom Stage Data (Prismatic) Listed below (Recalc)

Elevation (feet)	Surf.Area (sq-ft)	Inc.Store (cubic-feet)	Cum.Store (cubic-feet)
666.25	1	0	0
669.15	1	3	3
669.70	3,725	1,025	1,028

Device	Routing	Invert	Outlet Devices
#1	Primary	666.25'	12.0" Round Culvert L= 170.0' CPP, square edge headwall, Ke= 0.500 Inlet / Outlet Invert= 666.25' / 665.91' S= 0.0020 '/' Cc= 0.900 n= 0.012, Flow Area= 0.79 sf

Primary OutFlow Max=1.65 cfs @ 12.10 hrs HW=668.33' TW=667.91' (Dynamic Tailwater)
 ↑**1=Culvert** (Outlet Controls 1.65 cfs @ 2.10 fps)

Pond 25P: YD#11

Hydrograph

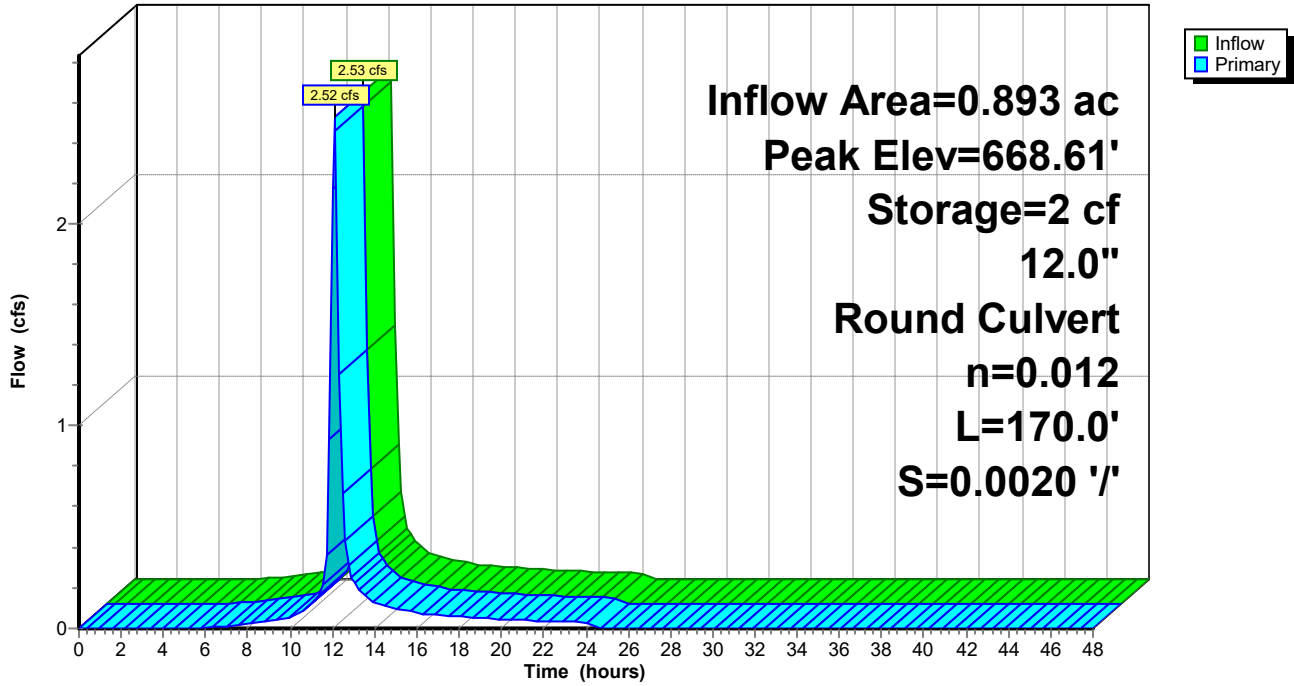

Plug Power - Proposed Conditions 5-15-21

Type II 24-hr 25-yr Rainfall=3.71"

Prepared by {enter your company name here}

Printed 5/20/2021

HydroCAD® 10.10-5a s/n 11585 © 2020 HydroCAD Software Solutions LLC

Page 214

Summary for Pond 27P: CB#4

Inflow Area = 0.946 ac, 62.20% Impervious, Inflow Depth = 2.74" for 25-yr event
Inflow = 2.76 cfs @ 12.10 hrs, Volume= 0.216 af
Outflow = 2.75 cfs @ 12.10 hrs, Volume= 0.216 af, Atten= 0%, Lag= 0.0 min
Primary = 2.75 cfs @ 12.10 hrs, Volume= 0.216 af

Routing by Dyn-Stor-Ind method, Time Span= 0.00-48.00 hrs, dt= 0.15 hrs
Peak Elev= 668.23' @ 12.41 hrs Surf.Area= 4 sf Storage= 9 cf
Flood Elev= 669.15' Surf.Area= 5,345 sf Storage= 1,597 cf

Plug-Flow detention time= 2.3 min calculated for 0.216 af (100% of inflow)
Center-of-Mass det. time= 0.2 min (804.2 - 804.0)

Volume	Invert	Avail.Storage	Storage Description
#1	665.99'	1,597 cf	Custom Stage Data (Prismatic) Listed below (Recalc)

Elevation (feet)	Surf.Area (sq-ft)	Inc.Store (cubic-feet)	Cum.Store (cubic-feet)
665.99	4	0	0
668.40	4	10	10
669.00	3,160	949	959
669.15	5,345	638	1,597

Device	Routing	Invert	Outlet Devices
#1	Primary	665.99'	12.0" Round Culvert L= 40.0' CPP, square edge headwall, Ke= 0.500 Inlet / Outlet Invert= 665.99' / 665.91' S= 0.0020 '/' Cc= 0.900 n= 0.012, Flow Area= 0.79 sf

Primary OutFlow Max=0.40 cfs @ 12.10 hrs HW=667.91' TW=667.90' (Dynamic Tailwater)
↑1=Culvert (Inlet Controls 0.40 cfs @ 0.51 fps)

Pond 27P: CB#4

Hydrograph

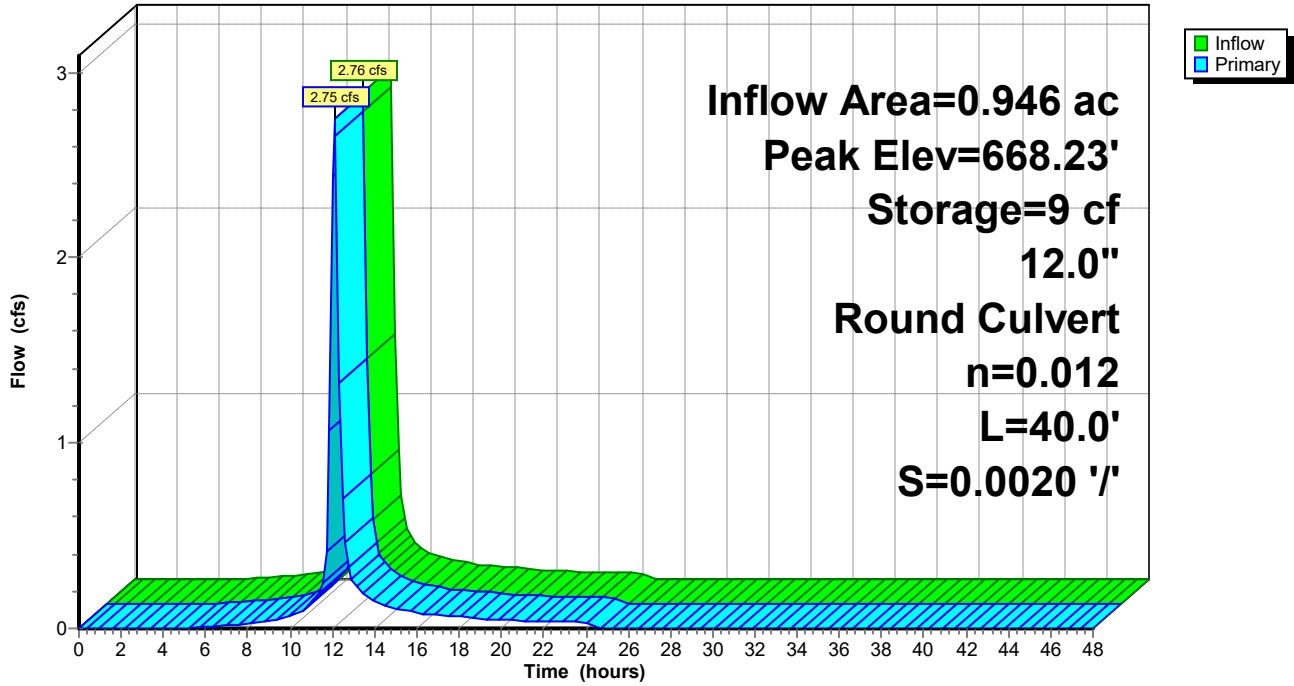

Plug Power - Proposed Conditions 5-15-21

Type II 24-hr 25-yr Rainfall=3.71"

Prepared by {enter your company name here}

Printed 5/20/2021

HydroCAD® 10.10-5a s/n 11585 © 2020 HydroCAD Software Solutions LLC

Page 216

Summary for Pond 28P: CB#15

Inflow Area = 2.230 ac, 65.51% Impervious, Inflow Depth = 2.83" for 25-yr event
 Inflow = 6.34 cfs @ 12.04 hrs, Volume= 0.526 af
 Outflow = 6.34 cfs @ 12.04 hrs, Volume= 0.526 af, Atten= 0%, Lag= 0.0 min
 Primary = 6.34 cfs @ 12.04 hrs, Volume= 0.526 af

Routing by Dyn-Stor-Ind method, Time Span= 0.00-48.00 hrs, dt= 0.15 hrs
 Peak Elev= 668.18' @ 12.29 hrs Surf.Area= 4 sf Storage= 9 cf
 Flood Elev= 669.20' Surf.Area= 4 sf Storage= 13 cf

Plug-Flow detention time= (not calculated: outflow precedes inflow)
 Center-of-Mass det. time= 0.1 min (794.0 - 793.9)

Volume	Invert	Avail.Storage	Storage Description
#1	665.91'	13 cf	Custom Stage Data (Prismatic) Listed below (Recalc)

Elevation (feet)	Surf.Area (sq-ft)	Inc.Store (cubic-feet)	Cum.Store (cubic-feet)
665.91	4	0	0
669.20	4	13	13

Device	Routing	Invert	Outlet Devices
#1	Primary	665.91'	18.0" Round Culvert L= 157.0' CPP, square edge headwall, Ke= 0.500 Inlet / Outlet Invert= 665.91' / 665.60' S= 0.0020 '/' Cc= 0.900 n= 0.012, Flow Area= 1.77 sf

Primary OutFlow Max=2.90 cfs @ 12.04 hrs HW=667.77' TW=667.62' (Dynamic Tailwater)

↑**1=Culvert** (Outlet Controls 2.90 cfs @ 1.69 fps)

Pond 28P: CB#15

Hydrograph

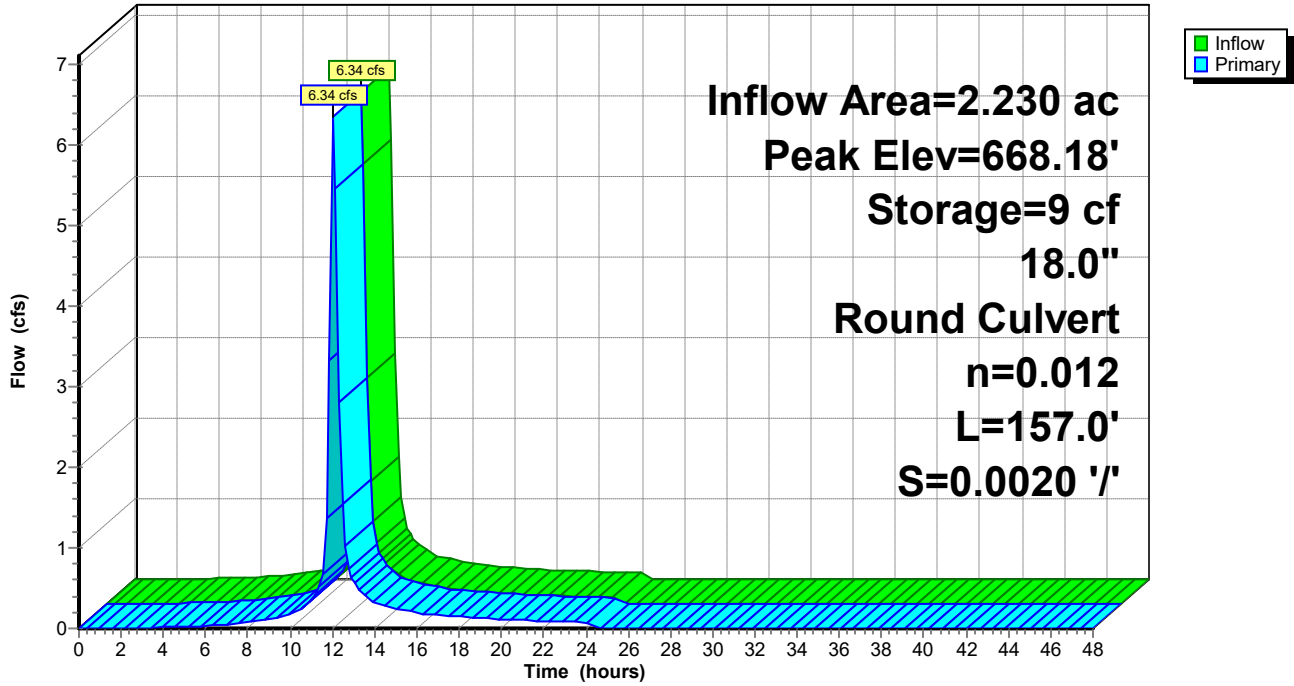

Plug Power - Proposed Conditions 5-15-21

Type II 24-hr 25-yr Rainfall=3.71"

Prepared by {enter your company name here}

Printed 5/20/2021

HydroCAD® 10.10-5a s/n 11585 © 2020 HydroCAD Software Solutions LLC

Page 218

Summary for Pond 29P: Dry Pond

Inflow Area = 0.745 ac, 0.00% Impervious, Inflow Depth = 10.82" for 25-yr event
 Inflow = 17.30 cfs @ 12.19 hrs, Volume= 0.672 af
 Outflow = 3.14 cfs @ 12.61 hrs, Volume= 0.672 af, Atten= 82%, Lag= 25.2 min
 Primary = 3.14 cfs @ 12.61 hrs, Volume= 0.672 af
 Tertiary = 0.00 cfs @ 0.00 hrs, Volume= 0.000 af

Routing by Dyn-Stor-Ind method, Time Span= 0.00-48.00 hrs, dt= 0.15 hrs
 Peak Elev= 664.97' @ 12.60 hrs Surf.Area= 11,994 sf Storage= 20,979 cf

Plug-Flow detention time= 89.0 min calculated for 0.670 af (100% of inflow)
 Center-of-Mass det. time= 89.0 min (840.5 - 751.5)

Volume	Invert	Avail.Storage	Storage Description
#1	662.56'	37,071 cf	Custom Stage Data (Prismatic) Listed below (Recalc)
Elevation (feet)	Surf.Area (sq-ft)	Inc.Store (cubic-feet)	Cum.Store (cubic-feet)
662.56	300	0	0
663.00	6,155	1,420	1,420
663.35	8,635	2,588	4,008
664.00	10,250	6,138	10,146
665.00	12,040	11,145	21,291
666.00	19,520	15,780	37,071

Device	Routing	Invert	Outlet Devices
#1	Primary	662.56'	12.0" Round Culvert L= 30.0' CPP, square edge headwall, Ke= 0.500 Inlet / Outlet Invert= 662.56' / 662.50' S= 0.0020 '/' Cc= 0.900 n= 0.012, Flow Area= 0.79 sf
#2	Primary	662.56'	12.0" Round Culvert L= 30.0' CPP, square edge headwall, Ke= 0.500 Inlet / Outlet Invert= 662.56' / 662.50' S= 0.0020 '/' Cc= 0.900 n= 0.012, Flow Area= 0.79 sf
#3	Device 1	662.56'	3.0" Vert. Orifice/Grate C= 0.600 Limited to weir flow at low heads
#4	Device 2	662.56'	3.0" Vert. Orifice/Grate C= 0.600 Limited to weir flow at low heads
#5	Device 1	663.06'	6.0" Vert. Orifice/Grate C= 0.600 Limited to weir flow at low heads
#6	Device 2	663.06'	6.0" Vert. Orifice/Grate C= 0.600 Limited to weir flow at low heads
#7	Device 1	665.20'	1.4" x 4.5" Horiz. Orifice/Grate X 72.00 C= 0.600 Limited to weir flow at low heads
#8	Device 2	665.20'	1.4" x 4.5" Horiz. Orifice/Grate X 72.00 C= 0.600 Limited to weir flow at low heads
#9	Tertiary	665.70'	100.0' long x 2.0' breadth Broad-Crested Rectangular Weir Head (feet) 0.20 0.40 0.60 0.80 1.00 1.20 1.40 1.60 1.80 2.00 2.50 3.00 3.50 Coef. (English) 2.54 2.61 2.61 2.60 2.66 2.70 2.77 2.89 2.88 2.85 3.07 3.20 3.32

Plug Power - Proposed Conditions 5-15-21

Prepared by {enter your company name here}

HydroCAD® 10.10-5a s/n 11585 © 2020 HydroCAD Software Solutions LLC

Type II 24-hr 25-yr Rainfall=3.71"

Printed 5/20/2021

Page 219

Primary OutFlow Max=3.14 cfs @ 12.61 hrs HW=664.97' TW=662.76' (Dynamic Tailwater)

- 1=Culvert (Passes 1.57 cfs of 5.04 cfs potential flow)
- 3=Orifice/Grate (Orifice Controls 0.35 cfs @ 7.15 fps)
- 5=Orifice/Grate (Orifice Controls 1.22 cfs @ 6.20 fps)
- 7=Orifice/Grate (Controls 0.00 cfs)
- 2=Culvert (Passes 1.57 cfs of 5.04 cfs potential flow)
- 4=Orifice/Grate (Orifice Controls 0.35 cfs @ 7.15 fps)
- 6=Orifice/Grate (Orifice Controls 1.22 cfs @ 6.20 fps)
- 8=Orifice/Grate (Controls 0.00 cfs)

Tertiary OutFlow Max=0.00 cfs @ 0.00 hrs HW=662.56' TW=662.30' (Dynamic Tailwater)

- 9=Broad-Crested Rectangular Weir (Controls 0.00 cfs)

Pond 29P: Dry Pond

Hydrograph

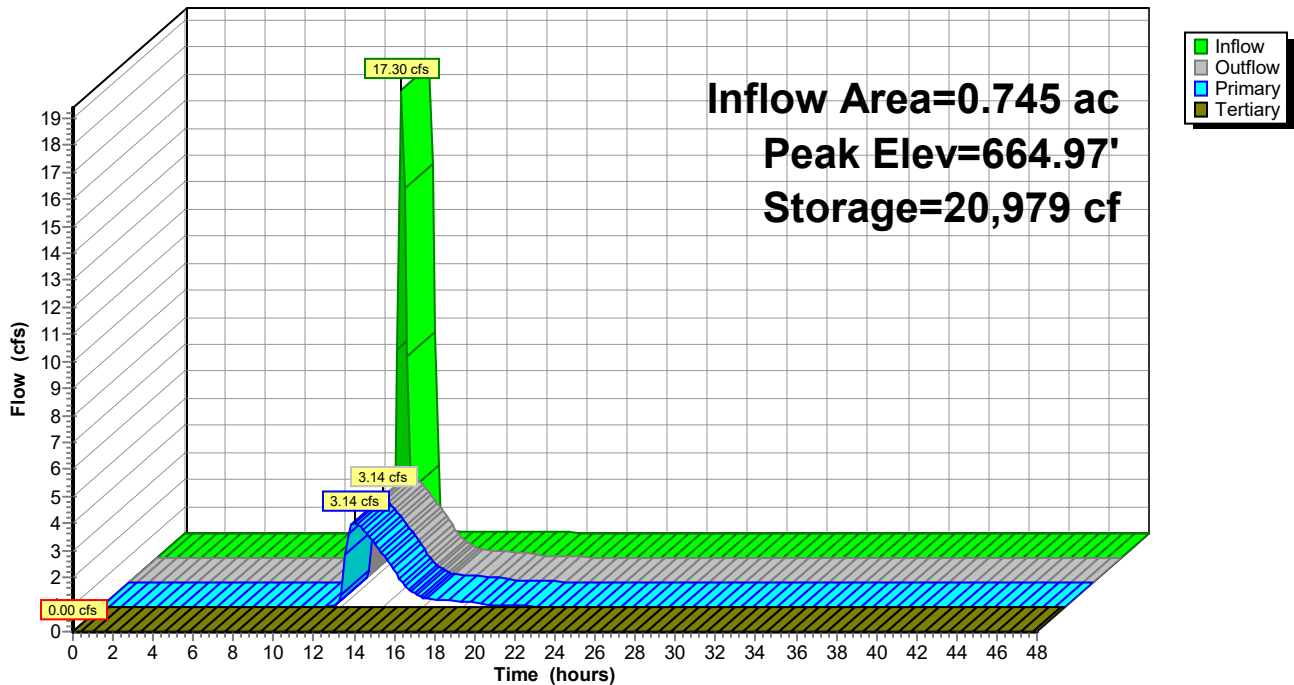

Plug Power - Proposed Conditions 5-15-21

Type II 24-hr 25-yr Rainfall=3.71"

Prepared by {enter your company name here}

Printed 5/20/2021

HydroCAD® 10.10-5a s/n 11585 © 2020 HydroCAD Software Solutions LLC

Page 220

Summary for Pond 31P: CB#18

Inflow Area = 2.692 ac, 56.86% Impervious, Inflow Depth = 2.67" for 25-yr event
Inflow = 6.96 cfs @ 12.06 hrs, Volume= 0.598 af
Outflow = 6.95 cfs @ 12.06 hrs, Volume= 0.599 af, Atten= 0%, Lag= 0.0 min
Primary = 6.95 cfs @ 12.06 hrs, Volume= 0.599 af

Routing by Dyn-Stor-Ind method, Time Span= 0.00-48.00 hrs, dt= 0.15 hrs
Peak Elev= 668.07' @ 12.20 hrs Surf.Area= 4 sf Storage= 10 cf
Flood Elev= 669.45' Surf.Area= 9,895 sf Storage= 3,378 cf

Plug-Flow detention time= (not calculated: outflow precedes inflow)
Center-of-Mass det. time= 0.1 min (800.3 - 800.2)

Volume	Invert	Avail.Storage	Storage Description
#1	665.60'	3,378 cf	Custom Stage Data (Prismatic) Listed below (Recalc)

Elevation (feet)	Surf.Area (sq-ft)	Inc.Store (cubic-feet)	Cum.Store (cubic-feet)
665.60	4	0	0
668.55	4	12	12
669.00	2,530	570	582
669.45	9,895	2,796	3,378

Device	Routing	Invert	Outlet Devices
#1	Primary	665.60'	18.0" Round Culvert L= 83.0' CPP, square edge headwall, Ke= 0.500 Inlet / Outlet Invert= 665.60' / 665.43' S= 0.0020 '/' Cc= 0.900 n= 0.012, Flow Area= 1.77 sf

Primary OutFlow Max=2.54 cfs @ 12.06 hrs HW=667.67' TW=667.58' (Dynamic Tailwater)
↑**1=Culvert** (Outlet Controls 2.54 cfs @ 1.44 fps)

Pond 31P: CB#18

Hydrograph

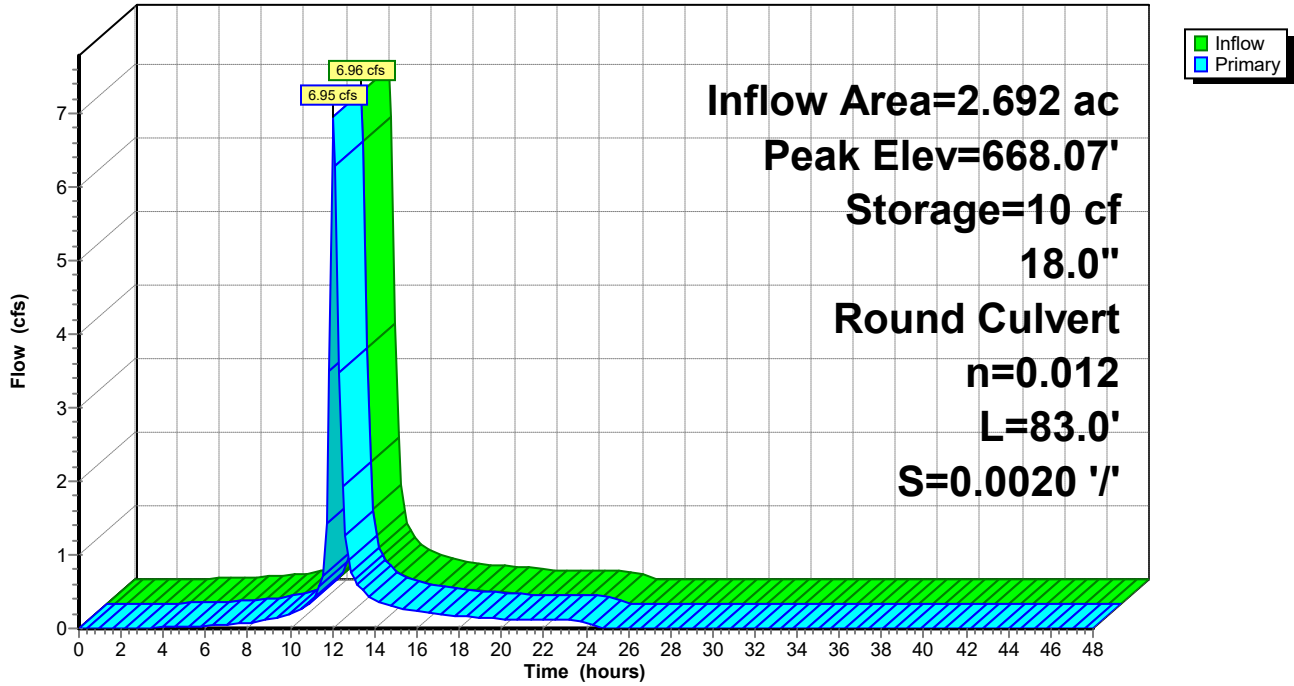

Plug Power - Proposed Conditions 5-15-21

Type II 24-hr 25-yr Rainfall=3.71"

Prepared by {enter your company name here}

Printed 5/20/2021

HydroCAD® 10.10-5a s/n 11585 © 2020 HydroCAD Software Solutions LLC

Page 222

Summary for Pond 33P: CB#26

Inflow Area = 0.831 ac, 69.35% Impervious, Inflow Depth = 2.84" for 25-yr event
Inflow = 2.49 cfs @ 12.09 hrs, Volume= 0.197 af
Outflow = 2.49 cfs @ 12.10 hrs, Volume= 0.197 af, Atten= 0%, Lag= 0.1 min
Primary = 2.49 cfs @ 12.10 hrs, Volume= 0.197 af

Routing by Dyn-Stor-Ind method, Time Span= 0.00-48.00 hrs, dt= 0.15 hrs
Peak Elev= 667.68' @ 12.73 hrs Surf.Area= 4 sf Storage= 9 cf
Flood Elev= 669.00' Surf.Area= 3,160 sf Storage= 961 cf

Plug-Flow detention time= 2.3 min calculated for 0.197 af (100% of inflow)
Center-of-Mass det. time= 0.2 min (799.6 - 799.4)

Volume	Invert	Avail.Storage	Storage Description
#1	665.42'	1,599 cf	Custom Stage Data (Prismatic) Listed below (Recalc)

Elevation (feet)	Surf.Area (sq-ft)	Inc.Store (cubic-feet)	Cum.Store (cubic-feet)
665.42	4	0	0
668.40	4	12	12
669.00	3,160	949	961
669.15	5,345	638	1,599

Device	Routing	Invert	Outlet Devices
#1	Primary	665.42'	12.0" Round Culvert L= 175.0' CPP, square edge headwall, Ke= 0.500 Inlet / Outlet Invert= 665.42' / 665.07' S= 0.0020 '/' Cc= 0.900 n= 0.012, Flow Area= 0.79 sf

Primary OutFlow Max=1.80 cfs @ 12.10 hrs HW=667.06' TW=666.56' (Dynamic Tailwater)
↑**1=Culvert** (Outlet Controls 1.80 cfs @ 2.29 fps)

Pond 33P: CB#26

Hydrograph

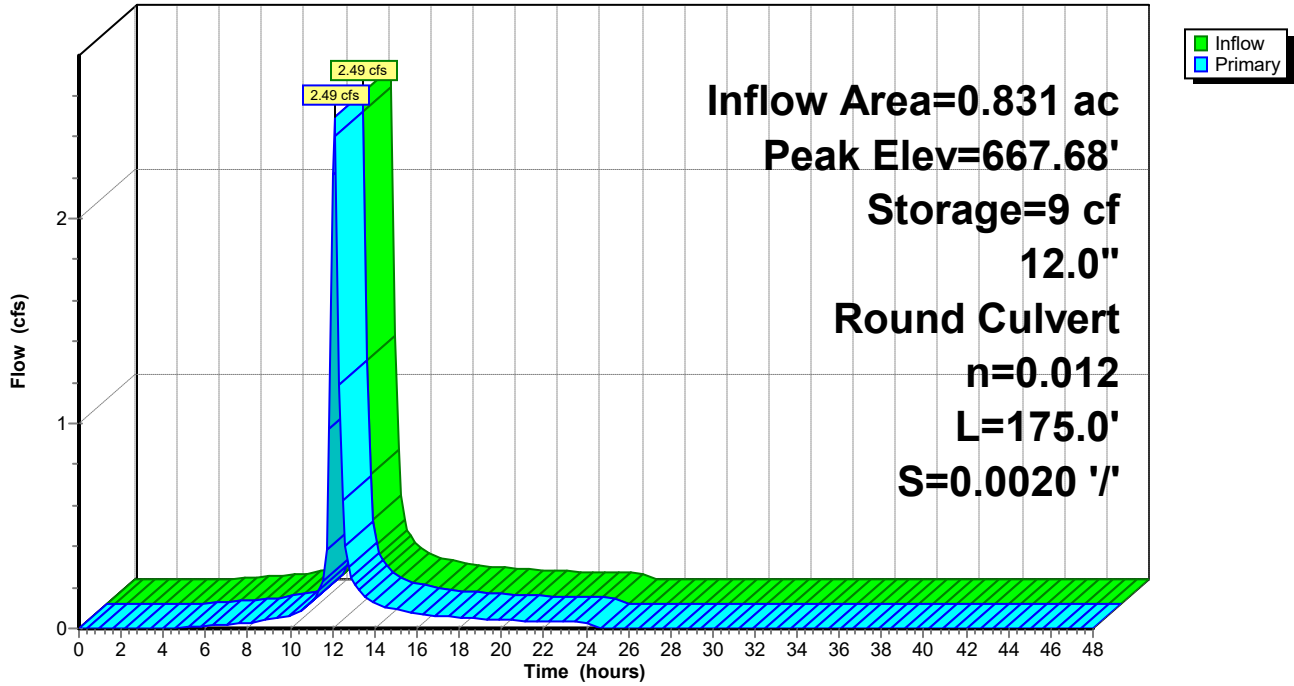

Plug Power - Proposed Conditions 5-15-21

Type II 24-hr 25-yr Rainfall=3.71"

Prepared by {enter your company name here}

Printed 5/20/2021

HydroCAD® 10.10-5a s/n 11585 © 2020 HydroCAD Software Solutions LLC

Page 224

Summary for Pond 37P: CB#28

Inflow Area = 1.256 ac, 61.06% Impervious, Inflow Depth = 2.71" for 25-yr event
Inflow = 3.59 cfs @ 12.11 hrs, Volume= 0.284 af
Outflow = 3.58 cfs @ 12.11 hrs, Volume= 0.284 af, Atten= 0%, Lag= 0.0 min
Primary = 3.58 cfs @ 12.11 hrs, Volume= 0.284 af

Routing by Dyn-Stor-Ind method, Time Span= 0.00-48.00 hrs, dt= 0.15 hrs
Peak Elev= 667.67' @ 12.58 hrs Surf.Area= 4 sf Storage= 10 cf
Flood Elev= 669.75' Surf.Area= 5,170 sf Storage= 1,569 cf

Plug-Flow detention time= 0.1 min calculated for 0.283 af (100% of inflow)
Center-of-Mass det. time= 0.1 min (805.5 - 805.4)

Volume	Invert	Avail.Storage	Storage Description
#1	665.07'	1,569 cf	Custom Stage Data (Prismatic) Listed below (Recalc)

Elevation (feet)	Surf.Area (sq-ft)	Inc.Store (cubic-feet)	Cum.Store (cubic-feet)
665.07	4	0	0
669.15	4	16	16
669.75	5,170	1,552	1,569

Device	Routing	Invert	Outlet Devices
#1	Primary	665.07'	15.0" Round Culvert L= 214.0' CPP, square edge headwall, Ke= 0.500 Inlet / Outlet Invert= 665.07' / 664.64' S= 0.0020 '/' Cc= 0.900 n= 0.012, Flow Area= 1.23 sf

Primary OutFlow Max=1.17 cfs @ 12.11 hrs HW=666.59' TW=666.52' (Dynamic Tailwater)
↑**1=Culvert** (Outlet Controls 1.17 cfs @ 1.00 fps)

Pond 37P: CB#28

Hydrograph

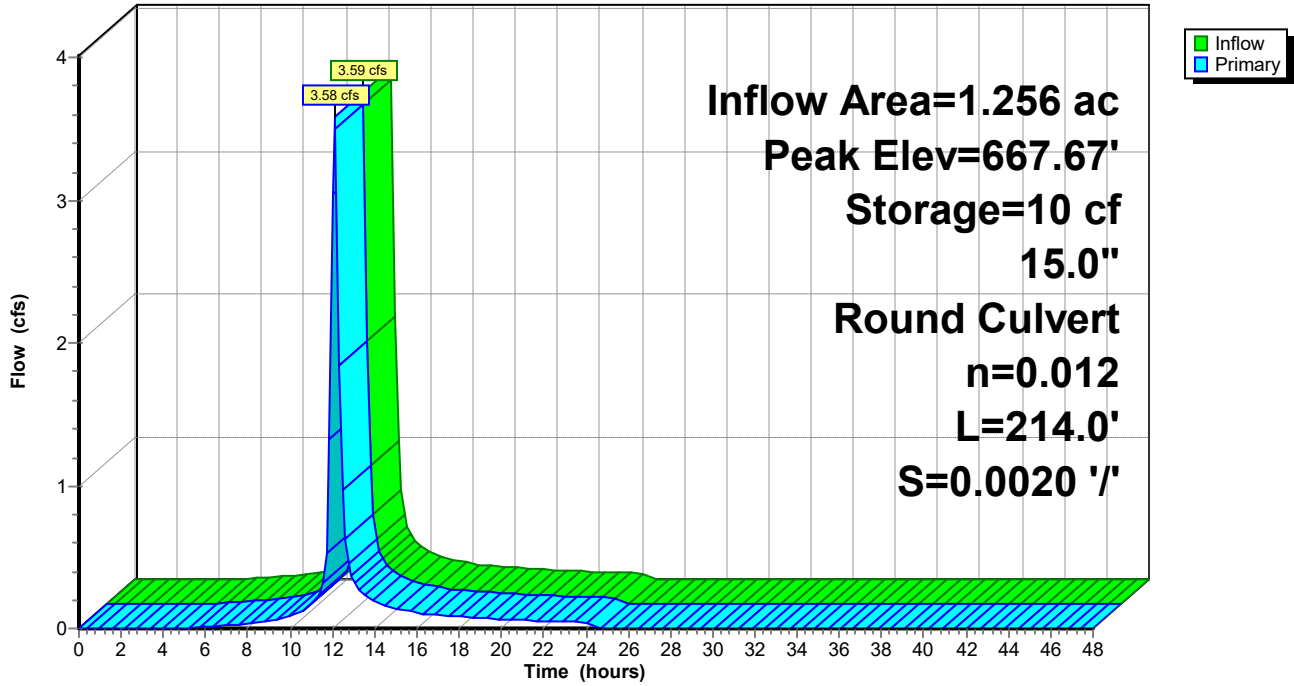

Plug Power - Proposed Conditions 5-15-21

Type II 24-hr 25-yr Rainfall=3.71"

Prepared by {enter your company name here}

Printed 5/20/2021

HydroCAD® 10.10-5a s/n 11585 © 2020 HydroCAD Software Solutions LLC

Page 226

Summary for Pond 39P: CB#30

Inflow Area = 2.166 ac, 42.53% Impervious, Inflow Depth = 2.43" for 25-yr event
Inflow = 5.50 cfs @ 12.12 hrs, Volume= 0.438 af
Outflow = 5.49 cfs @ 12.12 hrs, Volume= 0.438 af, Atten= 0%, Lag= 0.0 min
Primary = 5.49 cfs @ 12.12 hrs, Volume= 0.438 af

Routing by Dyn-Stor-Ind method, Time Span= 0.00-48.00 hrs, dt= 0.15 hrs
Peak Elev= 667.64' @ 12.44 hrs Surf.Area= 4 sf Storage= 12 cf
Flood Elev= 668.00' Surf.Area= 220 sf Storage= 19 cf

Plug-Flow detention time= 0.1 min calculated for 0.437 af (100% of inflow)
Center-of-Mass det. time= 0.1 min (816.5 - 816.4)

Volume	Invert	Avail.Storage	Storage Description
#1	664.64'	19 cf	Custom Stage Data (Prismatic) Listed below (Recalc)

Elevation (feet)	Surf.Area (sq-ft)	Inc.Store (cubic-feet)	Cum.Store (cubic-feet)
664.64	4	0	0
667.95	4	13	13
668.00	220	6	19

Device	Routing	Invert	Outlet Devices
#1	Primary	664.64'	18.0" Round Culvert L= 150.0' CPP, square edge headwall, Ke= 0.500 Inlet / Outlet Invert= 664.64' / 664.34' S= 0.0020 '/' Cc= 0.900 n= 0.012, Flow Area= 1.77 sf

Primary OutFlow Max=0.00 cfs @ 12.12 hrs HW=666.58' TW=666.99' (Dynamic Tailwater)
↑1=Culvert (Controls 0.00 cfs)

Pond 39P: CB#30

Hydrograph

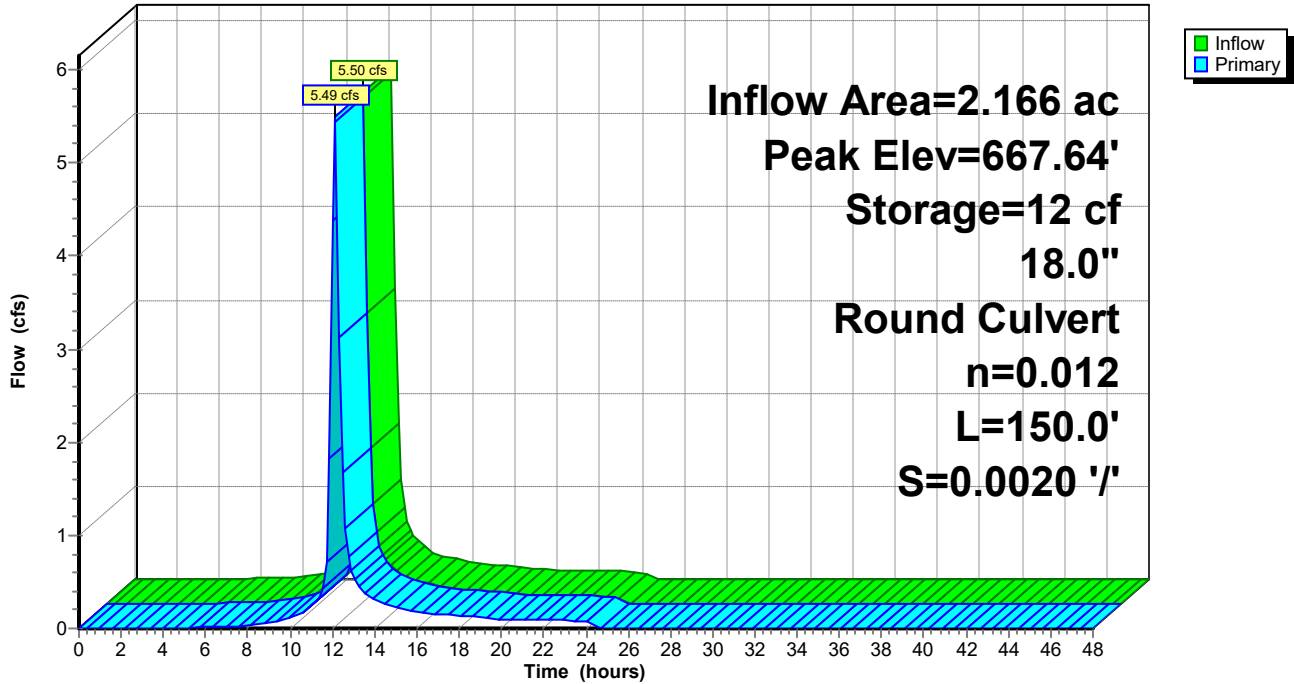

Plug Power - Proposed Conditions 5-15-21

Type II 24-hr 25-yr Rainfall=3.71"

Prepared by {enter your company name here}

Printed 5/20/2021

HydroCAD® 10.10-5a s/n 11585 © 2020 HydroCAD Software Solutions LLC

Page 228

Summary for Pond 41P: CB#32

Inflow Area = 2.889 ac, 56.91% Impervious, Inflow Depth = 2.69" for 25-yr event
Inflow = 7.76 cfs @ 12.13 hrs, Volume= 0.648 af
Outflow = 7.75 cfs @ 12.13 hrs, Volume= 0.648 af, Atten= 0%, Lag= 0.0 min
Primary = 7.75 cfs @ 12.13 hrs, Volume= 0.648 af

Routing by Dyn-Stor-Ind method, Time Span= 0.00-48.00 hrs, dt= 0.15 hrs
Peak Elev= 667.59' @ 12.31 hrs Surf.Area= 4 sf Storage= 13 cf
Flood Elev= 668.00' Surf.Area= 5 sf Storage= 15 cf

Plug-Flow detention time= 0.1 min calculated for 0.646 af (100% of inflow)
Center-of-Mass det. time= 0.1 min (799.7 - 799.7)

Volume	Invert	Avail.Storage	Storage Description
#1	664.34'	3,522 cf	Custom Stage Data (Prismatic) Listed below (Recalc)

Elevation (feet)	Surf.Area (sq-ft)	Inc.Store (cubic-feet)	Cum.Store (cubic-feet)
664.34	4	0	0
667.95	4	14	14
688.05	345	3,507	3,522

Device	Routing	Invert	Outlet Devices
#1	Primary	664.34'	24.0" Round Culvert L= 166.0' CPP, square edge headwall, Ke= 0.500 Inlet / Outlet Invert= 664.34' / 664.01' S= 0.0020 '/' Cc= 0.900 n= 0.012, Flow Area= 3.14 sf

Primary OutFlow Max=0.00 cfs @ 12.13 hrs HW=667.04' TW=667.39' (Dynamic Tailwater)
↑1=Culvert (Controls 0.00 cfs)

Pond 41P: CB#32

Hydrograph

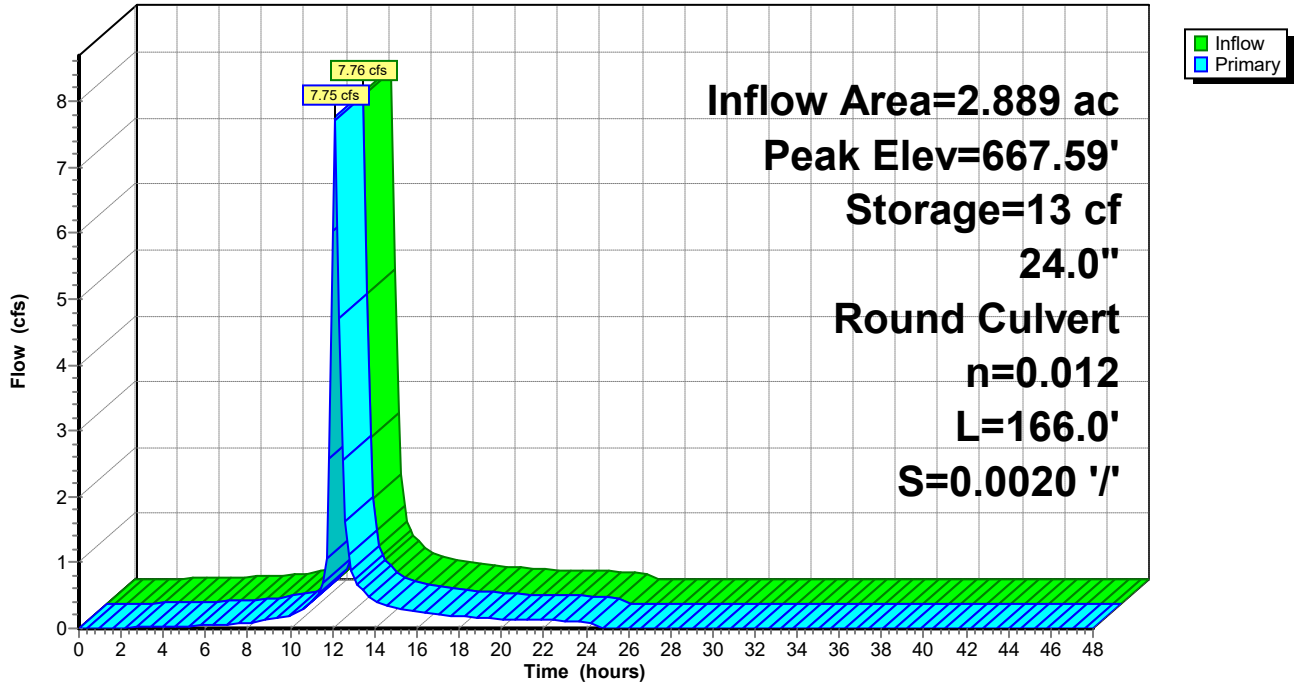

Plug Power - Proposed Conditions 5-15-21

Type II 24-hr 25-yr Rainfall=3.71"

Prepared by {enter your company name here}

Printed 5/20/2021

HydroCAD® 10.10-5a s/n 11585 © 2020 HydroCAD Software Solutions LLC

Page 230

Summary for Pond 44P: CB#24

Inflow Area = 4.895 ac, 67.05% Impervious, Inflow Depth = 2.84" for 25-yr event
 Inflow = 13.78 cfs @ 12.00 hrs, Volume= 1.158 af
 Outflow = 13.78 cfs @ 12.00 hrs, Volume= 1.158 af, Atten= 0%, Lag= 0.0 min
 Primary = 13.78 cfs @ 12.00 hrs, Volume= 1.158 af

Routing by Dyn-Stor-Ind method, Time Span= 0.00-48.00 hrs, dt= 0.15 hrs
 Peak Elev= 667.60' @ 12.30 hrs
 Flood Elev= 669.85'

Device #	Routing	Invert	Outlet Devices
#1	Primary	665.12'	24.0" Round Culvert L= 105.0' CPP, square edge headwall, Ke= 0.500 Inlet / Outlet Invert= 665.12' / 664.91' S= 0.0020 '/ Cc= 0.900 n= 0.012, Flow Area= 3.14 sf

Primary OutFlow Max=11.93 cfs @ 12.00 hrs HW=667.48' TW=666.86' (Dynamic Tailwater)
 ↑1=Culvert (Inlet Controls 11.93 cfs @ 3.80 fps)

Pond 44P: CB#24

Hydrograph

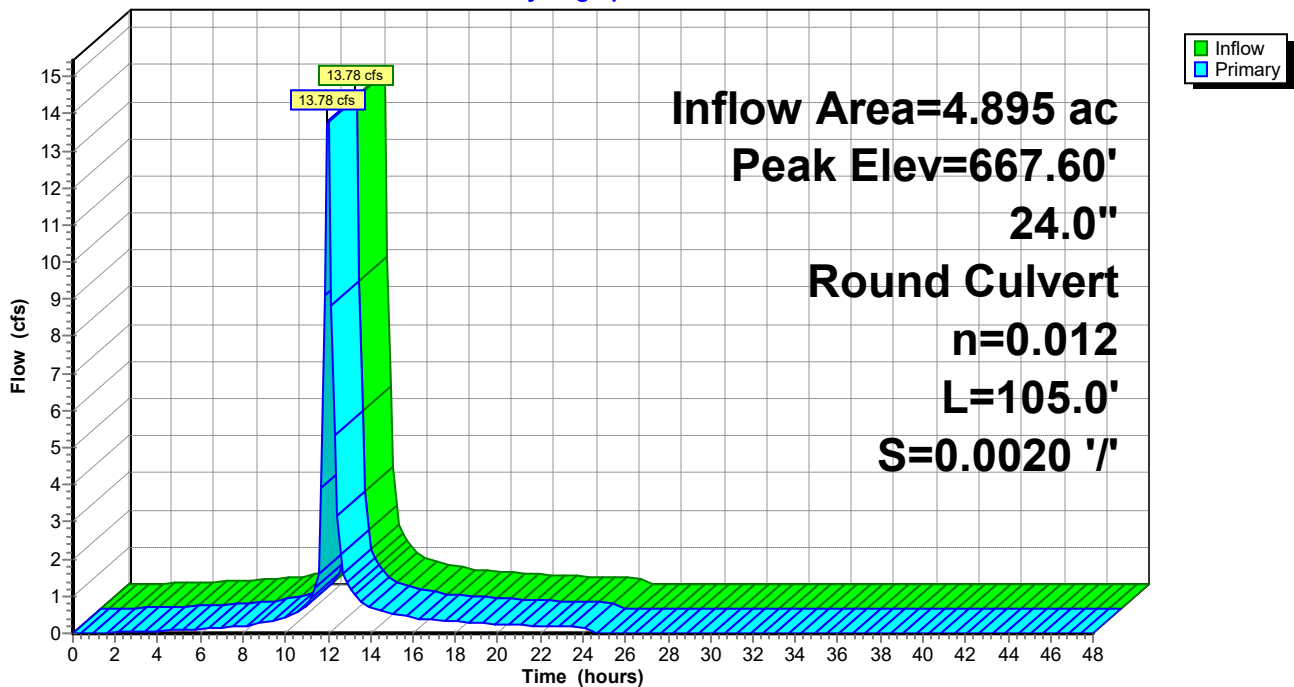

Plug Power - Proposed Conditions 5-15-21

Type II 24-hr 25-yr Rainfall=3.71"

Prepared by {enter your company name here}

Printed 5/20/2021

HydroCAD® 10.10-5a s/n 11585 © 2020 HydroCAD Software Solutions LLC

Page 231

Summary for Pond 46P: CB#20

Inflow Area = 3.433 ac, 66.17% Impervious, Inflow Depth = 2.84" for 25-yr event
Inflow = 9.69 cfs @ 12.01 hrs, Volume= 0.813 af
Outflow = 9.69 cfs @ 12.01 hrs, Volume= 0.813 af, Atten= 0%, Lag= 0.0 min
Primary = 9.69 cfs @ 12.01 hrs, Volume= 0.813 af

Routing by Dyn-Stor-Ind method, Time Span= 0.00-48.00 hrs, dt= 0.15 hrs

Peak Elev= 667.74' @ 12.14 hrs

Flood Elev= 669.85'

Device	Routing	Invert	Outlet Devices
#1	Primary	665.43'	24.0" Round Culvert L= 157.0' CPP, square edge headwall, Ke= 0.500 Inlet / Outlet Invert= 665.43' / 665.12' S= 0.0020 '/ Cc= 0.900 n= 0.012, Flow Area= 3.14 sf

Primary OutFlow Max=1.82 cfs @ 12.01 hrs HW=667.50' TW=667.48' (Dynamic Tailwater)
↑1=Culvert (Outlet Controls 1.82 cfs @ 0.70 fps)

Pond 46P: CB#20

Hydrograph

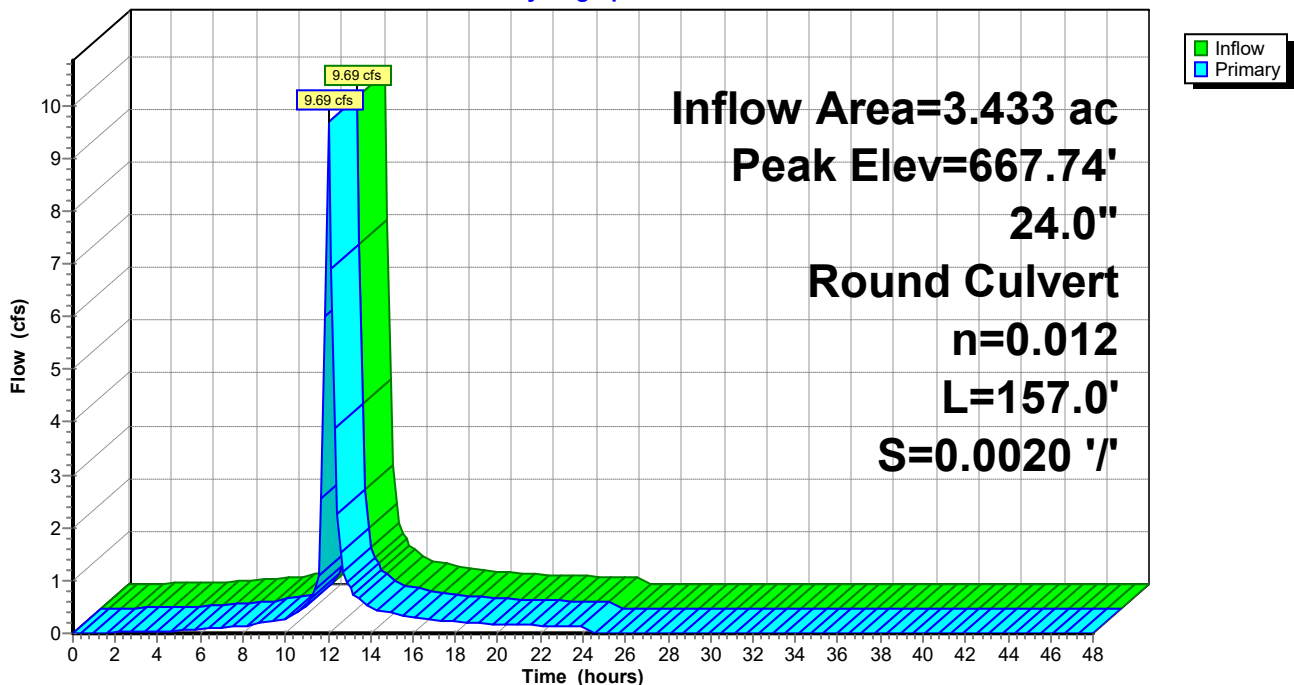

Plug Power - Proposed Conditions 5-15-21

Type II 24-hr 25-yr Rainfall=3.71"

Prepared by {enter your company name here}

Printed 5/20/2021

HydroCAD® 10.10-5a s/n 11585 © 2020 HydroCAD Software Solutions LLC

Page 232

Summary for Pond 50P: YD#8

Inflow Area = 2.660 ac, 32.37% Impervious, Inflow Depth = 2.25" for 25-yr event
Inflow = 5.67 cfs @ 12.18 hrs, Volume= 0.499 af
Outflow = 5.67 cfs @ 12.18 hrs, Volume= 0.499 af, Atten= 0%, Lag= 0.0 min
Primary = 5.67 cfs @ 12.18 hrs, Volume= 0.499 af

Routing by Dyn-Stor-Ind method, Time Span= 0.00-48.00 hrs, dt= 0.15 hrs
Peak Elev= 668.80' @ 12.25 hrs Surf.Area= 1 sf Storage= 2 cf
Flood Elev= 669.90' Surf.Area= 8,385 sf Storage= 3,357 cf

Plug-Flow detention time= 0.0 min calculated for 0.497 af (100% of inflow)
Center-of-Mass det. time= 0.0 min (831.9 - 831.9)

Volume	Invert	Avail.Storage	Storage Description
#1	666.95'	3,357 cf	Custom Stage Data (Prismatic) Listed below (Recalc)

Elevation (feet)	Surf.Area (sq-ft)	Inc.Store (cubic-feet)	Cum.Store (cubic-feet)
666.95	1	0	0
669.10	1	2	2
669.90	8,385	3,354	3,357

Device	Routing	Invert	Outlet Devices
#1	Primary	666.95'	18.0" Round Culvert L= 122.0' CPP, square edge headwall, Ke= 0.500 Inlet / Outlet Invert= 666.95' / 666.71' S= 0.0020 '/' Cc= 0.900 n= 0.012, Flow Area= 1.77 sf

Primary OutFlow Max=4.71 cfs @ 12.18 hrs HW=668.71' TW=668.34' (Dynamic Tailwater)
1=Culvert (Outlet Controls 4.71 cfs @ 2.85 fps)

Pond 50P: YD#8

Hydrograph

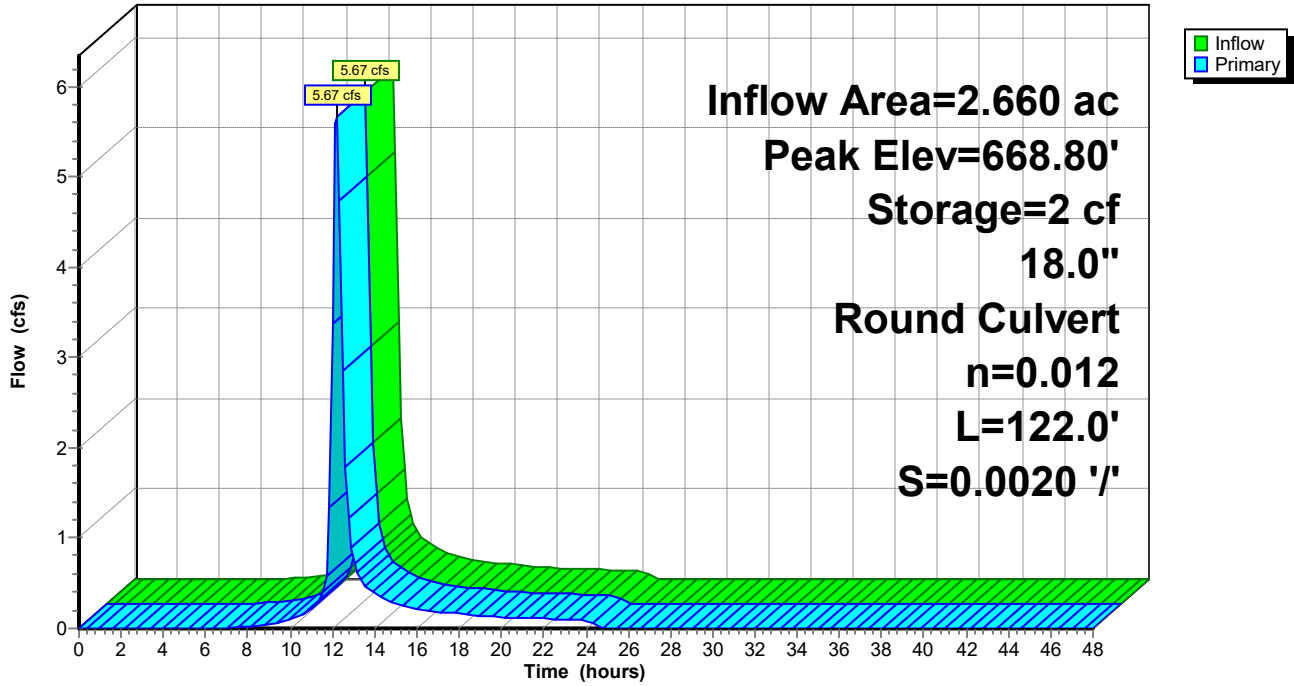

Plug Power - Proposed Conditions 5-15-21

Type II 24-hr 25-yr Rainfall=3.71"

Prepared by {enter your company name here}

Printed 5/20/2021

HydroCAD® 10.10-5a s/n 11585 © 2020 HydroCAD Software Solutions LLC

Page 234

Summary for Pond 51P: YD#6

Inflow Area = 1.879 ac, 30.11% Impervious, Inflow Depth = 2.20" for 25-yr event
Inflow = 3.87 cfs @ 12.19 hrs, Volume= 0.344 af
Outflow = 3.87 cfs @ 12.19 hrs, Volume= 0.344 af, Atten= 0%, Lag= 0.0 min
Primary = 3.87 cfs @ 12.19 hrs, Volume= 0.344 af

Routing by Dyn-Stor-Ind method, Time Span= 0.00-48.00 hrs, dt= 0.15 hrs
Peak Elev= 669.19' @ 12.32 hrs Surf.Area= 1 sf Storage= 2 cf
Flood Elev= 669.70' Surf.Area= 7,065 sf Storage= 1,592 cf

Plug-Flow detention time= 0.0 min calculated for 0.343 af (100% of inflow)
Center-of-Mass det. time= 0.0 min (834.5 - 834.5)

Volume	Invert	Avail.Storage	Storage Description
#1	667.23'	1,592 cf	Custom Stage Data (Prismatic) Listed below (Recalc)

Elevation (feet)	Surf.Area (sq-ft)	Inc.Store (cubic-feet)	Cum.Store (cubic-feet)
667.23	1	0	0
669.25	1	2	2
669.70	7,065	1,590	1,592

Device	Routing	Invert	Outlet Devices
#1	Primary	667.23'	15.0" Round Culvert L= 138.0' CPP, square edge headwall, Ke= 0.500 Inlet / Outlet Invert= 667.23' / 666.95' S= 0.0020 '/' Cc= 0.900 n= 0.012, Flow Area= 1.23 sf

Primary OutFlow Max=1.77 cfs @ 12.19 hrs HW=668.84' TW=668.72' (Dynamic Tailwater)
↑**1=Culvert** (Outlet Controls 1.77 cfs @ 1.46 fps)

Pond 51P: YD#6

Hydrograph

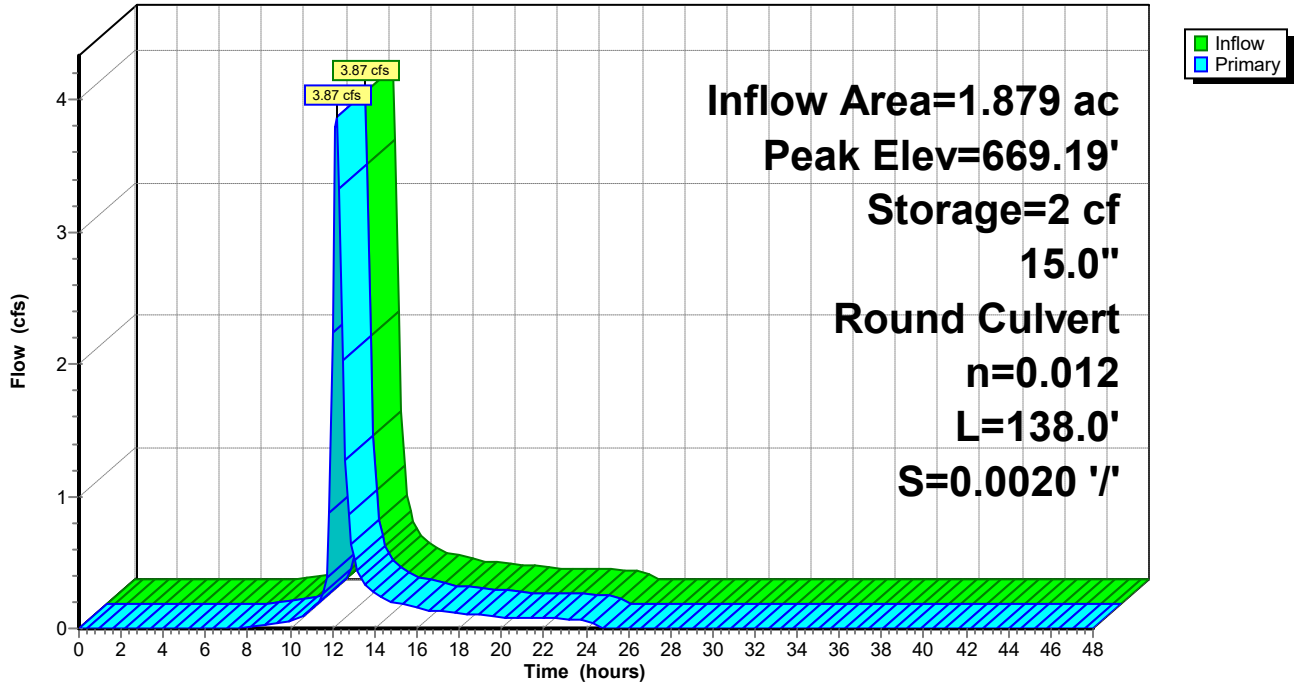

Summary for Link 52L: Total Site Discharge

Inflow Area = 29.096 ac, 42.99% Impervious, Inflow Depth = 2.44" for 25-yr event
Inflow = 19.06 cfs @ 12.80 hrs, Volume= 5.905 af
Primary = 19.06 cfs @ 12.80 hrs, Volume= 5.905 af, Atten= 0%, Lag= 0.0 min

Primary outflow = Inflow, Time Span= 0.00-48.00 hrs, dt= 0.15 hrs

Link 52L: Total Site Discharge

Hydrograph

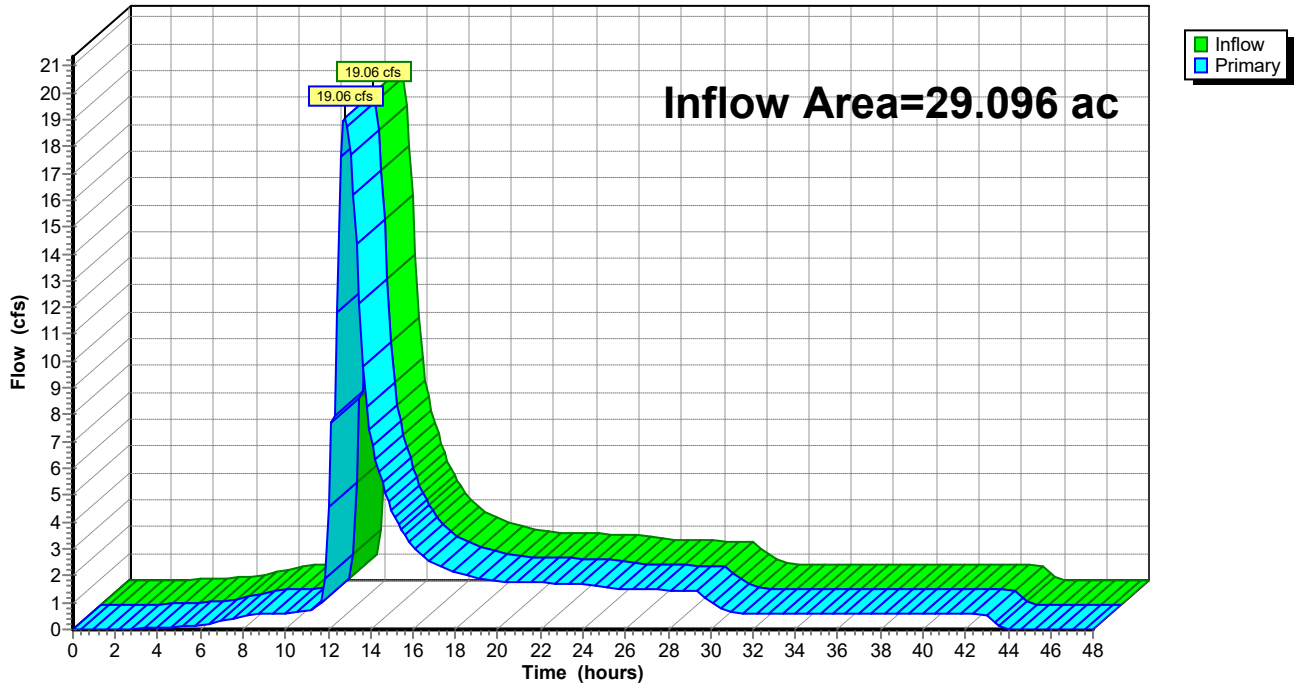

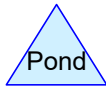
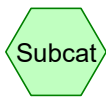
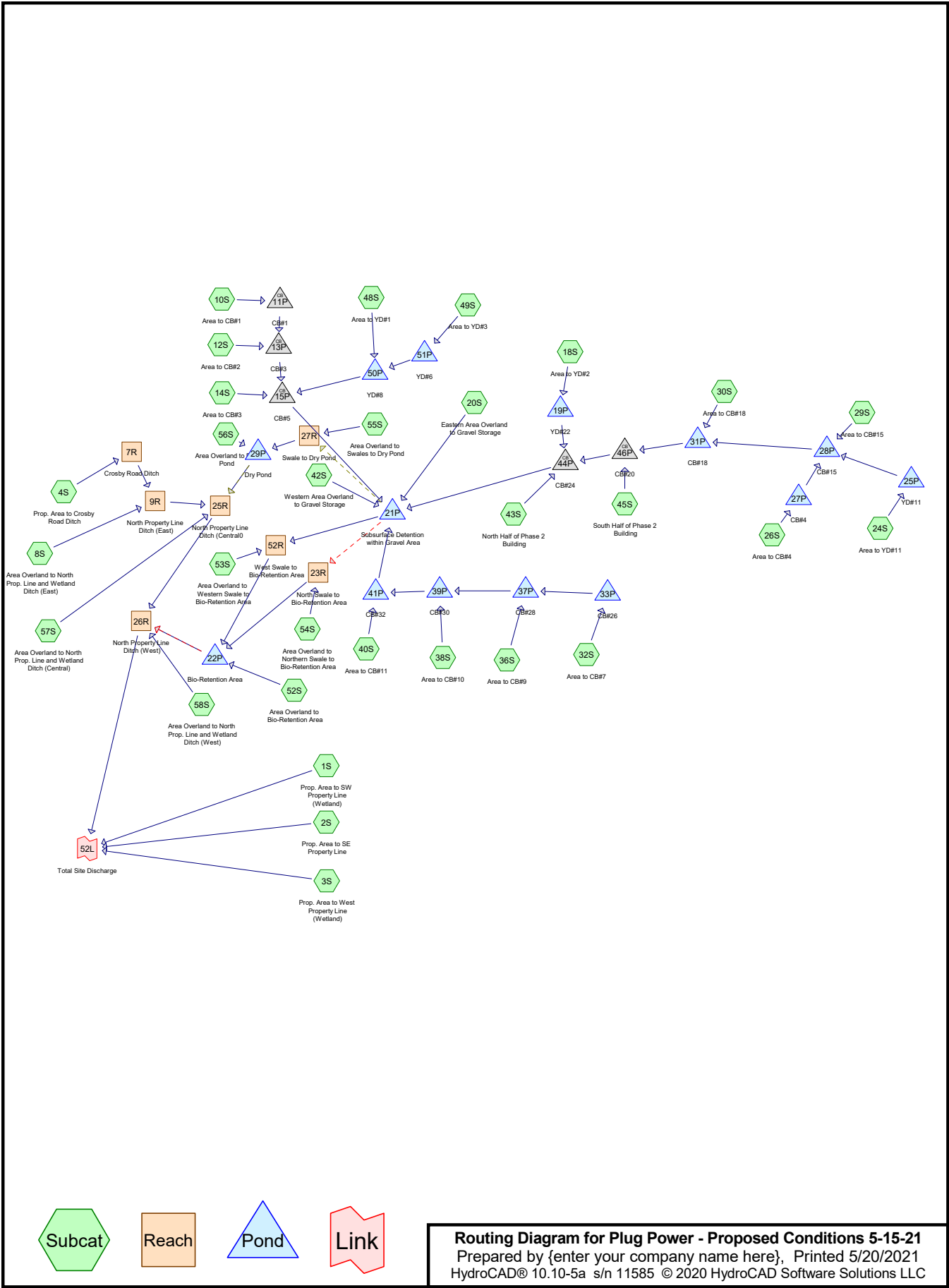

Routing Diagram for Plug Power - Proposed Conditions 5-15-21
 Prepared by {enter your company name here}, Printed 5/20/2021
 HydroCAD® 10.10-5a s/n 11585 © 2020 HydroCAD Software Solutions LLC

Plug Power - Proposed Conditions 5-15-21

Prepared by {enter your company name here}

HydroCAD® 10.10-5a s/n 11585 © 2020 HydroCAD Software Solutions LLC

Printed 5/20/2021

Page 2

Project Notes

Defined 9 rainfall events from Gateway IDF

Plug Power - Proposed Conditions 5-15-21

Prepared by {enter your company name here}

HydroCAD® 10.10-5a s/n 11585 © 2020 HydroCAD Software Solutions LLC

Printed 5/20/2021

Page 3

Area Listing (all nodes)

Area (acres)	CN	Description (subcatchment-numbers)
9.685	80	>75% Grass cover, Good, HSG D (1S, 3S, 10S, 12S, 14S, 18S, 20S, 24S, 26S, 30S, 32S, 36S, 38S, 42S, 48S, 49S, 52S, 53S, 54S, 55S, 56S)
2.105	77	Brush, Fair, HSG D (8S, 57S, 58S)
3.004	80	Gravel Storage Area, Good, HSG D (20S, 42S)
0.667	78	Meadow, non-grazed, HSG D (1S, 3S, 38S)
5.945	98	Paved parking, HSG D (10S, 12S, 14S, 20S, 24S, 26S, 32S, 36S, 38S, 40S, 42S, 48S, 49S)
5.115	98	Roofs, HSG D (10S, 12S, 20S, 24S, 26S, 29S, 42S, 43S, 45S, 48S, 49S)
1.449	98	Unconnected pavement, HSG D (18S, 20S, 30S, 36S, 42S)
0.610	79	Woods, Fair, HSG D (1S, 38S)
0.516	79	Woods/grass comb., Good, HSG D (2S, 4S)
29.096	87	TOTAL AREA

Plug Power - Proposed Conditions 5-15-21

Prepared by {enter your company name here}

Printed 5/20/2021

HydroCAD® 10.10-5a s/n 11585 © 2020 HydroCAD Software Solutions LLC

Page 4

Soil Listing (all nodes)

Area (acres)	Soil Group	Subcatchment Numbers
0.000	HSG A	
0.000	HSG B	
0.000	HSG C	
29.096	HSG D	1S, 2S, 3S, 4S, 8S, 10S, 12S, 14S, 18S, 20S, 24S, 26S, 29S, 30S, 32S, 36S, 38S, 40S, 42S, 43S, 45S, 48S, 49S, 52S, 53S, 54S, 55S, 56S, 57S, 58S
0.000	Other	
29.096		TOTAL AREA

Plug Power - Proposed Conditions 5-15-21

Prepared by {enter your company name here}

Printed 5/20/2021

HydroCAD® 10.10-5a s/n 11585 © 2020 HydroCAD Software Solutions LLC

Page 5

Ground Covers (all nodes)

HSG-A (acres)	HSG-B (acres)	HSG-C (acres)	HSG-D (acres)	Other (acres)	Total (acres)	Ground Cover	Subcatchment Numbers
0.000	0.000	0.000	9.685	0.000	9.685	>75% Grass cover, Good	1S, 3S, 10S, 12S, 14S, 18S, 20S, 24S, 26S, 30S, 32S, 36S, 38S, 42S, 48S, 49S, 52S, 53S, 54S, 55S, 56S
0.000	0.000	0.000	2.105	0.000	2.105	Brush, Fair	8S, 57S, 58S
0.000	0.000	0.000	3.004	0.000	3.004	Gravel Storage Area, Good	20S, 42S
0.000	0.000	0.000	0.667	0.000	0.667	Meadow, non-grazed	1S, 3S, 38S
0.000	0.000	0.000	5.945	0.000	5.945	Paved parking	10S, 12S, 14S, 20S, 24S, 26S, 32S, 36S, 38S, 40S, 42S, 48S, 49S

Plug Power - Proposed Conditions 5-15-21

Prepared by {enter your company name here}

Printed 5/20/2021

HydroCAD® 10.10-5a s/n 11585 © 2020 HydroCAD Software Solutions LLC

Page 6

Ground Covers (all nodes) (continued)

HSG-A (acres)	HSG-B (acres)	HSG-C (acres)	HSG-D (acres)	Other (acres)	Total (acres)	Ground Cover	Subcatchment Numbers
0.000	0.000	0.000	5.115	0.000	5.115	Roofs	10S, 12S, 20S, 24S, 26S, 29S, 42S, 43S, 45S, 48S, 49S
0.000	0.000	0.000	1.449	0.000	1.449	Unconnected pavement	18S, 20S, 30S, 36S, 42S
0.000	0.000	0.000	0.610	0.000	0.610	Woods, Fair	1S, 38S
0.000	0.000	0.000	0.516	0.000	0.516	Woods/grass comb., Good	2S, 4S
0.000	0.000	0.000	29.096	0.000	29.096	TOTAL AREA	

Plug Power - Proposed Conditions 5-15-21

Prepared by {enter your company name here}

HydroCAD® 10.10-5a s/n 11585 © 2020 HydroCAD Software Solutions LLC

Printed 5/20/2021

Page 7

Pipe Listing (all nodes)

Line#	Node Number	In-Invert (feet)	Out-Invert (feet)	Length (feet)	Slope (ft/ft)	n	Width (inches)	Diam/Height (inches)	Inside-Fill (inches)
1	11P	667.41	667.14	137.0	0.0020	0.012	0.0	12.0	0.0
2	13P	667.14	666.71	213.0	0.0020	0.012	0.0	12.0	0.0
3	15P	666.71	666.35	180.0	0.0020	0.012	0.0	24.0	0.0
4	19P	665.26	665.12	70.0	0.0020	0.012	0.0	10.0	0.0
5	21P	664.01	663.90	57.0	0.0019	0.012	0.0	18.0	0.0
6	21P	664.01	663.90	57.0	0.0019	0.012	0.0	18.0	0.0
7	21P	665.95	665.85	50.0	0.0020	0.012	0.0	18.0	0.0
8	22P	660.55	660.50	25.0	0.0020	0.012	0.0	15.0	0.0
9	22P	660.55	660.50	25.0	0.0020	0.012	0.0	15.0	0.0
10	22P	660.56	660.55	5.0	0.0020	0.012	0.0	4.0	0.0
11	22P	660.56	660.55	5.0	0.0020	0.012	0.0	4.0	0.0
12	25P	666.25	665.91	170.0	0.0020	0.012	0.0	12.0	0.0
13	27P	665.99	665.91	40.0	0.0020	0.012	0.0	12.0	0.0
14	28P	665.91	665.60	157.0	0.0020	0.012	0.0	18.0	0.0
15	29P	662.56	662.50	30.0	0.0020	0.012	0.0	12.0	0.0
16	29P	662.56	662.50	30.0	0.0020	0.012	0.0	12.0	0.0
17	31P	665.60	665.43	83.0	0.0020	0.012	0.0	18.0	0.0
18	33P	665.42	665.07	175.0	0.0020	0.012	0.0	12.0	0.0
19	37P	665.07	664.64	214.0	0.0020	0.012	0.0	15.0	0.0
20	39P	664.64	664.34	150.0	0.0020	0.012	0.0	18.0	0.0
21	41P	664.34	664.01	166.0	0.0020	0.012	0.0	24.0	0.0
22	44P	665.12	664.91	105.0	0.0020	0.012	0.0	24.0	0.0
23	46P	665.43	665.12	157.0	0.0020	0.012	0.0	24.0	0.0
24	50P	666.95	666.71	122.0	0.0020	0.012	0.0	18.0	0.0
25	51P	667.23	666.95	138.0	0.0020	0.012	0.0	15.0	0.0

Plug Power - Proposed Conditions 5-15-21

Type II 24-hr 100-yr Rainfall=5.01"

Prepared by {enter your company name here}

Printed 5/20/2021

HydroCAD® 10.10-5a s/n 11585 © 2020 HydroCAD Software Solutions LLC

Page 8

Time span=0.00-48.00 hrs, dt=0.79 hrs, 62 points x 2
 Runoff by SCS TR-20 method, UH=SCS, Weighted-CN
 Reach routing by Dyn-Stor-Ind method - Pond routing by Dyn-Stor-Ind method

Subcatchment 1S: Prop. Area to SW Runoff Area=25,495 sf 0.00% Impervious Runoff Depth=2.81"
 Flow Length=90' Slope=0.0200 '/' Tc=20.5 min CN=79 Runoff=0.76 cfs 0.137 af

Subcatchment 2S: Prop. Area to SE Runoff Area=12,470 sf 0.00% Impervious Runoff Depth=2.81"
 Flow Length=100' Slope=0.0150 '/' Tc=19.6 min CN=79 Runoff=0.38 cfs 0.067 af

Subcatchment 3S: Prop. Area to West Runoff Area=38,190 sf 0.00% Impervious Runoff Depth=2.81"
 Flow Length=350' Tc=18.2 min CN=79 Runoff=1.22 cfs 0.205 af

Subcatchment 4S: Prop. Area to Crosby Runoff Area=10,015 sf 0.00% Impervious Runoff Depth=2.81"
 Flow Length=125' Slope=0.0100 '/' Tc=23.3 min CN=79 Runoff=0.28 cfs 0.054 af

Subcatchment 8S: Area Overland to North Runoff Area=51,085 sf 0.00% Impervious Runoff Depth=2.63"
 Flow Length=140' Tc=11.7 min CN=77 Runoff=1.77 cfs 0.257 af

Subcatchment 10S: Area to CB#1 Runoff Area=19,240 sf 67.06% Impervious Runoff Depth=4.10"
 Flow Length=80' Tc=12.8 min CN=92 Runoff=1.02 cfs 0.151 af

Subcatchment 12S: Area to CB#2 Runoff Area=12,315 sf 47.61% Impervious Runoff Depth=3.78"
 Flow Length=80' Tc=12.8 min CN=89 Runoff=0.61 cfs 0.089 af

Subcatchment 14S: Area to CB#3 Runoff Area=18,345 sf 46.99% Impervious Runoff Depth=3.68"
 Flow Length=260' Tc=19.1 min CN=88 Runoff=0.76 cfs 0.129 af

Subcatchment 18S: Area to YD#2 Runoff Area=27,200 sf 27.67% Impervious Runoff Depth=3.09"
 Flow Length=140' Slope=0.0100 '/' Tc=23.4 min UI Adjusted CN=82 Runoff=0.83 cfs 0.161 af

Subcatchment 20S: Eastern Area Runoff Area=329,310 sf 62.48% Impervious Runoff Depth=3.99"
 Flow Length=330' Tc=30.2 min CN=91 Runoff=12.36 cfs 2.515 af

Subcatchment 24S: Area to YD#11 Runoff Area=38,900 sf 53.89% Impervious Runoff Depth=3.89"
 Flow Length=70' Slope=0.0100 '/' Tc=17.3 min CN=90 Runoff=1.79 cfs 0.289 af

Subcatchment 26S: Area to CB#4 Runoff Area=41,205 sf 62.20% Impervious Runoff Depth=3.99"
 Flow Length=100' Tc=16.9 min CN=91 Runoff=1.97 cfs 0.315 af

Subcatchment 29S: Area to CB#15 Runoff Area=17,040 sf 100.00% Impervious Runoff Depth=4.77"
 Tc=5.0 min CN=98 Runoff=1.05 cfs 0.156 af

Subcatchment 30S: Area to CB#18 Runoff Area=20,100 sf 15.05% Impervious Runoff Depth=2.99"
 Flow Length=140' Slope=0.0100 '/' Tc=23.4 min UI Adjusted CN=81 Runoff=0.59 cfs 0.115 af

Subcatchment 32S: Area to CB#7 Runoff Area=36,220 sf 69.35% Impervious Runoff Depth=4.10"
 Flow Length=100' Tc=16.9 min CN=92 Runoff=1.77 cfs 0.284 af

Subcatchment 36S: Area to CB#9 Runoff Area=18,475 sf 44.79% Impervious Runoff Depth=3.68"
 Flow Length=80' Slope=0.0100 '/' Tc=19.3 min CN=88 Runoff=0.77 cfs 0.130 af

Plug Power - Proposed Conditions 5-15-21*Type II 24-hr 100-yr Rainfall=5.01"*

Prepared by {enter your company name here}

Printed 5/20/2021

HydroCAD® 10.10-5a s/n 11585 © 2020 HydroCAD Software Solutions LLC

Page 9

Subcatchment 38S: Area to CB#10	Runoff Area=39,650 sf 16.97% Impervious	Runoff Depth=3.18"
Flow Length=150'	Slope=0.0140 '/' Tc=20.6 min CN=83	Runoff=1.36 cfs 0.241 af
Subcatchment 40S: Area to CB#11	Runoff Area=31,495 sf 100.00% Impervious	Runoff Depth=4.77"
Flow Length=170'	Slope=0.0120 '/' Tc=22.1 min CN=98	Runoff=1.47 cfs 0.288 af
Subcatchment 42S: Western Area	Runoff Area=139,665 sf 42.71% Impervious	Runoff Depth=3.68"
Flow Length=50'	Slope=0.0200 '/' Tc=6.3 min CN=88	Runoff=7.21 cfs 0.983 af
Subcatchment 43S: North Half of Phase 2	Runoff Area=36,505 sf 100.00% Impervious	Runoff Depth=4.77"
	Tc=5.0 min CN=98	Runoff=2.26 cfs 0.333 af
Subcatchment 45S: South Half of Phase	Runoff Area=32,290 sf 100.00% Impervious	Runoff Depth=4.77"
	Tc=5.0 min CN=98	Runoff=2.00 cfs 0.295 af
Subcatchment 48S: Area to YD#1	Runoff Area=34,030 sf 37.80% Impervious	Runoff Depth=3.58"
Flow Length=150'	Slope=0.0100 '/' Tc=23.6 min CN=87	Runoff=1.21 cfs 0.233 af
Subcatchment 49S: Area to YD#3	Runoff Area=81,835 sf 30.11% Impervious	Runoff Depth=3.38"
Flow Length=340'	Tc=25.3 min CN=85	Runoff=2.63 cfs 0.529 af
Subcatchment 52S: Area Overland to	Runoff Area=71,325 sf 0.00% Impervious	Runoff Depth=2.90"
Flow Length=30'	Tc=5.4 min CN=80	Runoff=2.93 cfs 0.396 af
Subcatchment 53S: Area Overland to	Runoff Area=5,925 sf 0.00% Impervious	Runoff Depth=2.90"
	Tc=5.0 min CN=80	Runoff=0.24 cfs 0.033 af
Subcatchment 54S: Area Overland to	Runoff Area=6,040 sf 0.00% Impervious	Runoff Depth=2.90"
	Tc=5.0 min CN=80	Runoff=0.25 cfs 0.034 af
Subcatchment 55S: Area Overland to	Runoff Area=13,210 sf 0.00% Impervious	Runoff Depth=2.90"
Flow Length=25'	Slope=0.0100 '/' Tc=7.6 min CN=80	Runoff=0.53 cfs 0.073 af
Subcatchment 56S: Area Overland to Dry	Runoff Area=19,245 sf 0.00% Impervious	Runoff Depth=2.90"
	Tc=5.0 min CN=80	Runoff=0.79 cfs 0.107 af
Subcatchment 57S: Area Overland to North	Runoff Area=23,585 sf 0.00% Impervious	Runoff Depth=2.63"
Flow Length=100'	Tc=10.8 min CN=77	Runoff=0.83 cfs 0.119 af
Subcatchment 58S: Area Overland to North	Runoff Area=17,005 sf 0.00% Impervious	Runoff Depth=2.63"
Flow Length=170'	Tc=14.9 min CN=77	Runoff=0.55 cfs 0.086 af
Reach 7R: Crosby Road Ditch	Avg. Flow Depth=0.11' Max Vel=0.96 fps	Inflow=0.28 cfs 0.054 af
n=0.030 L=450.0' S=0.0089 '/'	Capacity=98.41 cfs	Outflow=0.27 cfs 0.054 af
Reach 9R: North Property Line Ditch	Avg. Flow Depth=0.26' Max Vel=1.44 fps	Inflow=1.98 cfs 0.311 af
n=0.030 L=670.0' S=0.0100 '/'	Capacity=634.40 cfs	Outflow=1.66 cfs 0.311 af
Reach 23R: North Swale to	Avg. Flow Depth=2.07' Max Vel=0.39 fps	Inflow=10.14 cfs 3.056 af
n=0.300 L=180.0' S=0.0050 '/'	Capacity=23.67 cfs	Outflow=9.97 cfs 3.056 af

Plug Power - Proposed Conditions 5-15-21

Type II 24-hr 100-yr Rainfall=5.01"

Prepared by {enter your company name here}

Printed 5/20/2021

HydroCAD® 10.10-5a s/n 11585 © 2020 HydroCAD Software Solutions LLC

Page 10

Reach 25R: North Property Line Ditch Avg. Flow Depth=0.72' Max Vel=1.71 fps Inflow=11.69 cfs 1.856 af
 n=0.030 L=500.0' S=0.0040 '/ Capacity=401.23 cfs Outflow=11.30 cfs 1.856 af

Reach 26R: North Property Line Ditch Avg. Flow Depth=1.27' Max Vel=1.83 fps Inflow=35.65 cfs 9.566 af
 n=0.030 L=500.0' S=0.0024 '/ Capacity=310.79 cfs Outflow=33.08 cfs 9.568 af

Reach 27R: Swale to Dry Pond Avg. Flow Depth=0.73' Max Vel=2.00 fps Inflow=11.83 cfs 1.319 af
 x 2.00 n=0.030 L=130.0' S=0.0050 '/ Capacity=118.87 cfs Outflow=11.53 cfs 1.320 af

Reach 52R: West Swale to Avg. Flow Depth=2.42' Max Vel=0.43 fps Inflow=14.63 cfs 4.160 af
 n=0.300 L=180.0' S=0.0050 '/ Capacity=23.67 cfs Outflow=14.26 cfs 4.160 af

Pond 11P: CB#1 Peak Elev=668.36' Inflow=1.02 cfs 0.151 af
 12.0" Round Culvert n=0.012 L=137.0' S=0.0020 '/ Outflow=1.02 cfs 0.151 af

Pond 13P: CB#3 Peak Elev=668.58' Inflow=1.63 cfs 0.240 af
 12.0" Round Culvert n=0.012 L=213.0' S=0.0020 '/ Outflow=1.63 cfs 0.240 af

Pond 15P: CB#5 Peak Elev=668.12' Inflow=6.15 cfs 1.131 af
 24.0" Round Culvert n=0.012 L=180.0' S=0.0020 '/ Outflow=6.15 cfs 1.131 af

Pond 19P: YD#22 Peak Elev=667.26' Storage=2 cf Inflow=0.83 cfs 0.161 af
 10.0" Round Culvert n=0.012 L=70.0' S=0.0020 '/ Outflow=0.83 cfs 0.161 af

Pond 21P: Subsurface Detention within Peak Elev=667.30' Storage=9,815 cf Inflow=39.32 cfs 7.235 af
 Primary=14.42 cfs 4.127 af Secondary=9.91 cfs 3.022 af Tertiary=11.33 cfs 1.246 af Outflow=35.64 cfs 7.238 af

Pond 22P: Bio-Retention Area Peak Elev=664.61' Storage=87,088 cf Inflow=25.35 cfs 7.611 af
 Primary=19.92 cfs 7.307 af Secondary=4.85 cfs 0.317 af Outflow=24.37 cfs 7.624 af

Pond 25P: YD#11 Peak Elev=667.89' Storage=2 cf Inflow=1.79 cfs 0.289 af
 12.0" Round Culvert n=0.012 L=170.0' S=0.0020 '/ Outflow=1.79 cfs 0.289 af

Pond 27P: CB#4 Peak Elev=667.72' Storage=7 cf Inflow=1.97 cfs 0.315 af
 12.0" Round Culvert n=0.012 L=40.0' S=0.0020 '/ Outflow=1.96 cfs 0.315 af

Pond 28P: CB#15 Peak Elev=667.72' Storage=7 cf Inflow=4.81 cfs 0.760 af
 18.0" Round Culvert n=0.012 L=157.0' S=0.0020 '/ Outflow=4.80 cfs 0.760 af

Pond 29P: Dry Pond Peak Elev=665.29' Storage=25,056 cf Inflow=12.25 cfs 1.427 af
 Primary=10.15 cfs 1.427 af Tertiary=0.00 cfs 0.000 af Outflow=10.15 cfs 1.427 af

Pond 31P: CB#18 Peak Elev=667.52' Storage=8 cf Inflow=5.38 cfs 0.875 af
 18.0" Round Culvert n=0.012 L=83.0' S=0.0020 '/ Outflow=5.38 cfs 0.875 af

Pond 33P: CB#26 Peak Elev=667.27' Storage=7 cf Inflow=1.77 cfs 0.284 af
 12.0" Round Culvert n=0.012 L=175.0' S=0.0020 '/ Outflow=1.77 cfs 0.284 af

Pond 37P: CB#28 Peak Elev=666.97' Storage=8 cf Inflow=2.53 cfs 0.414 af
 15.0" Round Culvert n=0.012 L=214.0' S=0.0020 '/ Outflow=2.53 cfs 0.414 af

Plug Power - Proposed Conditions 5-15-21

Type II 24-hr 100-yr Rainfall=5.01"

Prepared by {enter your company name here}

Printed 5/20/2021

HydroCAD® 10.10-5a s/n 11585 © 2020 HydroCAD Software Solutions LLC

Page 11

Pond 39P: CB#30 Peak Elev=667.28' Storage=11 cf Inflow=3.88 cfs 0.656 af
18.0" Round Culvert n=0.012 L=150.0' S=0.0020 '/ Outflow=3.88 cfs 0.656 af

Pond 41P: CB#32 Peak Elev=666.92' Storage=10 cf Inflow=5.35 cfs 0.943 af
24.0" Round Culvert n=0.012 L=166.0' S=0.0020 '/ Outflow=5.34 cfs 0.943 af

Pond 44P: CB#24 Peak Elev=667.30' Inflow=10.41 cfs 1.664 af
24.0" Round Culvert n=0.012 L=105.0' S=0.0020 '/ Outflow=10.41 cfs 1.664 af

Pond 46P: CB#20 Peak Elev=667.52' Inflow=7.36 cfs 1.170 af
24.0" Round Culvert n=0.012 L=157.0' S=0.0020 '/ Outflow=7.36 cfs 1.170 af

Pond 50P: YD#8 Peak Elev=668.46' Storage=2 cf Inflow=3.83 cfs 0.762 af
18.0" Round Culvert n=0.012 L=122.0' S=0.0020 '/ Outflow=3.83 cfs 0.762 af

Pond 51P: YD#6 Peak Elev=668.63' Storage=1 cf Inflow=2.63 cfs 0.529 af
15.0" Round Culvert n=0.012 L=138.0' S=0.0020 '/ Outflow=2.63 cfs 0.529 af

Link 52L: Total Site Discharge Inflow=34.14 cfs 9.977 af
Primary=34.14 cfs 9.977 af

Total Runoff Area = 29.096 ac Runoff Volume = 8.802 af Average Runoff Depth = 3.63"
57.01% Pervious = 16.587 ac 42.99% Impervious = 12.509 ac

Plug Power - Proposed Conditions 5-15-21

Type II 24-hr 100-yr Rainfall=5.01"

Prepared by {enter your company name here}

Printed 5/20/2021

HydroCAD® 10.10-5a s/n 11585 © 2020 HydroCAD Software Solutions LLC

Page 12

Summary for Subcatchment 1S: Prop. Area to SW Property Line (Wetland)

Runoff = 0.76 cfs @ 12.03 hrs, Volume= 0.137 af, Depth= 2.81"

Runoff by SCS TR-20 method, UH=SCS, Weighted-CN, Time Span= 0.00-48.19 hrs, dt= 0.79 hrs
Type II 24-hr 100-yr Rainfall=5.01"

Area (sf)	CN	Description
5,020	78	Meadow, non-grazed, HSG D
18,430	79	Woods, Fair, HSG D
2,045	80	>75% Grass cover, Good, HSG D
25,495	79	Weighted Average
25,495		100.00% Pervious Area

Tc (min)	Length (feet)	Slope (ft/ft)	Velocity (ft/sec)	Capacity (cfs)	Description
2.8	10	0.0200	0.06		Sheet Flow, 10' Overland Flow Grass: Dense n= 0.240 P2= 2.14"
5.1	40	0.0200	0.13		Sheet Flow, 40' Overland Flow Range n= 0.130 P2= 2.14"
12.6	40	0.0200	0.05		Sheet Flow, 40' Overland Flow Woods: Light underbrush n= 0.400 P2= 2.14"
20.5	90	Total			

Subcatchment 1S: Prop. Area to SW Property Line (Wetland)

Hydrograph

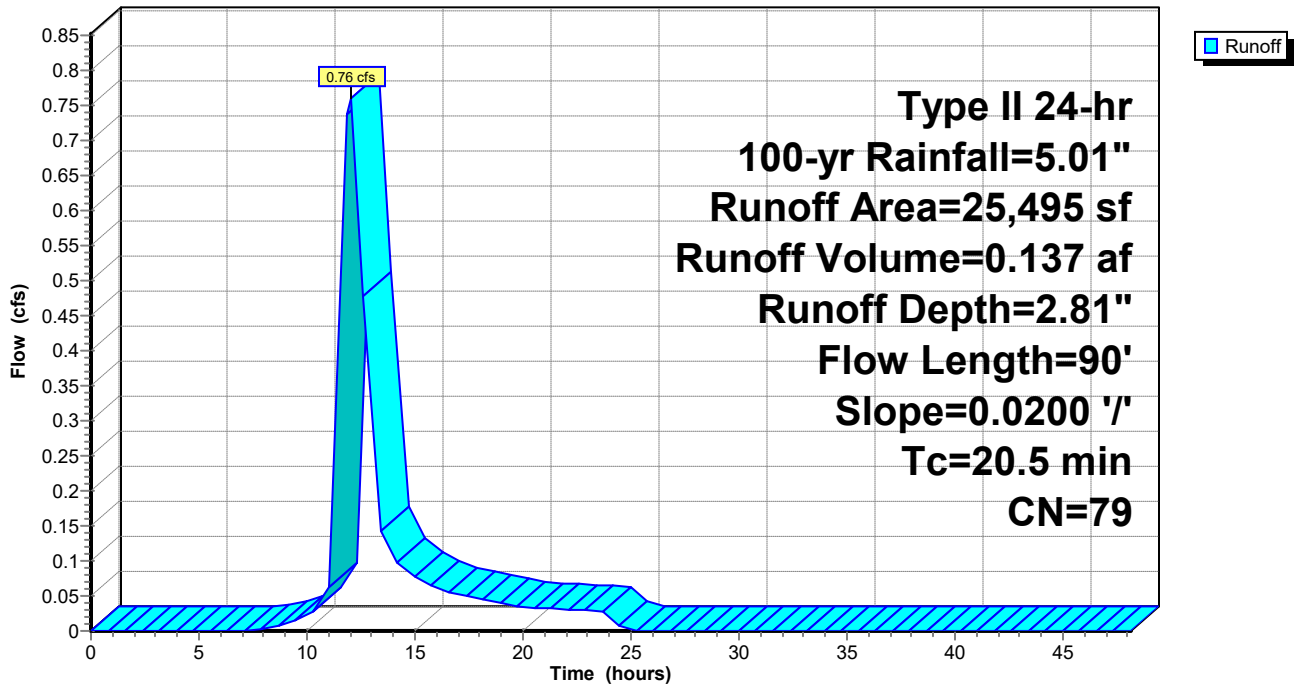

Plug Power - Proposed Conditions 5-15-21

Type II 24-hr 100-yr Rainfall=5.01"

Prepared by {enter your company name here}

Printed 5/20/2021

HydroCAD® 10.10-5a s/n 11585 © 2020 HydroCAD Software Solutions LLC

Page 13

Summary for Subcatchment 2S: Prop. Area to SE Property Line

Runoff = 0.38 cfs @ 12.00 hrs, Volume= 0.067 af, Depth= 2.81"

Runoff by SCS TR-20 method, UH=SCS, Weighted-CN, Time Span= 0.00-48.19 hrs, dt= 0.79 hrs
Type II 24-hr 100-yr Rainfall=5.01"

Area (sf)	CN	Description
12,470	79	Woods/grass comb., Good, HSG D
12,470		100.00% Pervious Area

Tc (min)	Length (feet)	Slope (ft/ft)	Velocity (ft/sec)	Capacity (cfs)	Description
19.6	100	0.0150	0.09		Sheet Flow, 100' Overland Flow Grass: Dense n= 0.240 P2= 2.14"

Subcatchment 2S: Prop. Area to SE Property Line

Hydrograph

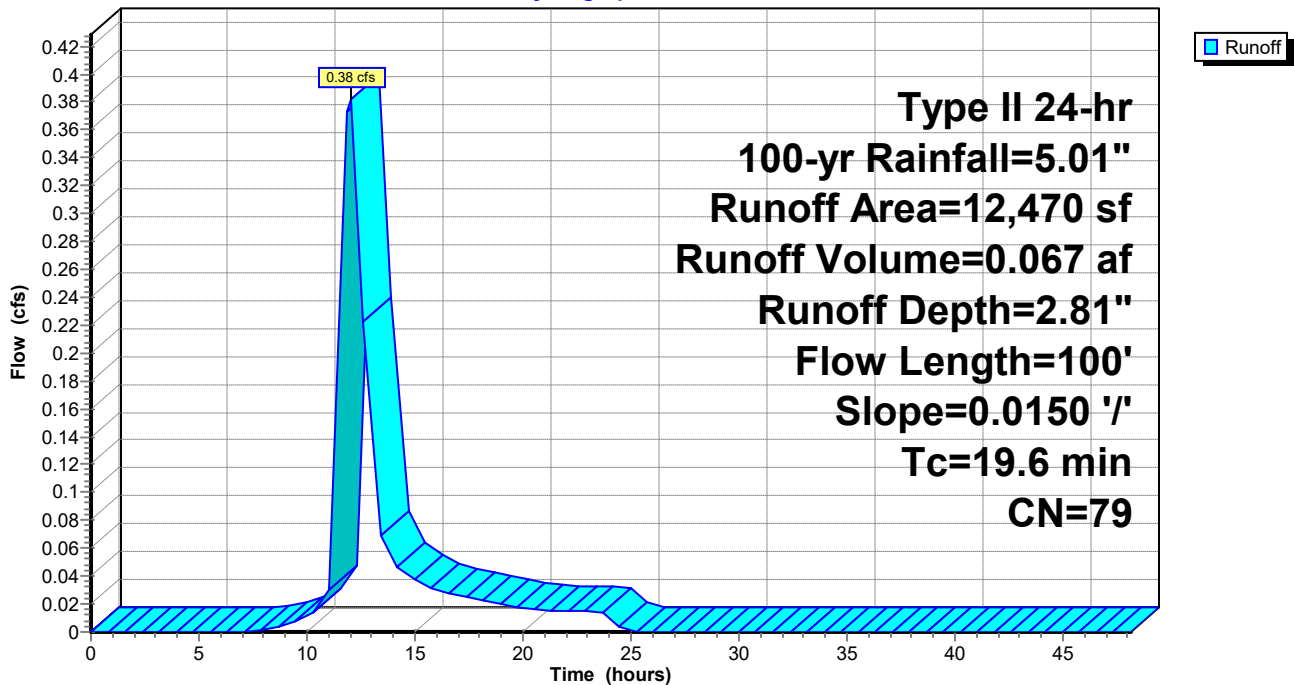

Plug Power - Proposed Conditions 5-15-21

Type II 24-hr 100-yr Rainfall=5.01"

Prepared by {enter your company name here}

Printed 5/20/2021

HydroCAD® 10.10-5a s/n 11585 © 2020 HydroCAD Software Solutions LLC

Page 14

Summary for Subcatchment 3S: Prop. Area to West Property Line (Wetland)

Runoff = 1.22 cfs @ 11.98 hrs, Volume= 0.205 af, Depth= 2.81"

Runoff by SCS TR-20 method, UH=SCS, Weighted-CN, Time Span= 0.00-48.19 hrs, dt= 0.79 hrs
 Type II 24-hr 100-yr Rainfall=5.01"

Area (sf)	CN	Description
20,080	80	>75% Grass cover, Good, HSG D
18,110	78	Meadow, non-grazed, HSG D
38,190	79	Weighted Average
38,190		100.00% Pervious Area

Tc (min)	Length (feet)	Slope (ft/ft)	Velocity (ft/sec)	Capacity (cfs)	Description
16.0	100	0.0250	0.10		Sheet Flow, 100' Overland Flow Grass: Dense n= 0.240 P2= 2.14"
2.2	250	0.0160	1.90		Shallow Concentrated Flow, 250' Shallow Conc. Flow Grassed Waterway Kv= 15.0 fps
18.2	350	Total			

Subcatchment 3S: Prop. Area to West Property Line (Wetland)

Hydrograph

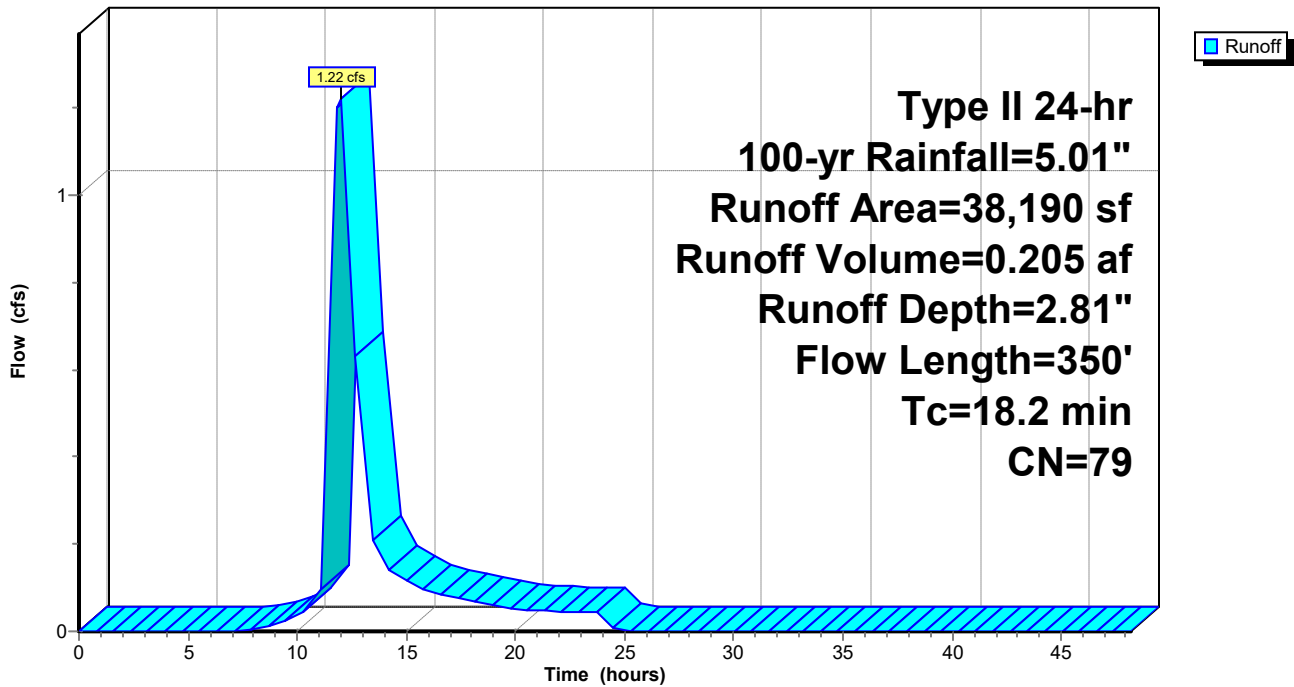

Plug Power - Proposed Conditions 5-15-21

Type II 24-hr 100-yr Rainfall=5.01"

Prepared by {enter your company name here}

Printed 5/20/2021

HydroCAD® 10.10-5a s/n 11585 © 2020 HydroCAD Software Solutions LLC

Page 15

Summary for Subcatchment 4S: Prop. Area to Crosby Road Ditch

Runoff = 0.28 cfs @ 12.12 hrs, Volume= 0.054 af, Depth= 2.81"

Runoff by SCS TR-20 method, UH=SCS, Weighted-CN, Time Span= 0.00-48.19 hrs, dt= 0.79 hrs
Type II 24-hr 100-yr Rainfall=5.01"

Area (sf)	CN	Description
10,015	79	Woods/grass comb., Good, HSG D
10,015		100.00% Pervious Area

Tc (min)	Length (feet)	Slope (ft/ft)	Velocity (ft/sec)	Capacity (cfs)	Description
23.0	100	0.0100	0.07		Sheet Flow, 100' Overland Flow Grass: Dense n= 0.240 P2= 2.14"
0.3	25	0.0100	1.50		Shallow Concentrated Flow, 25' Shallow Conc. Flow Grassed Waterway Kv= 15.0 fps
23.3	125	Total			

Subcatchment 4S: Prop. Area to Crosby Road Ditch

Hydrograph

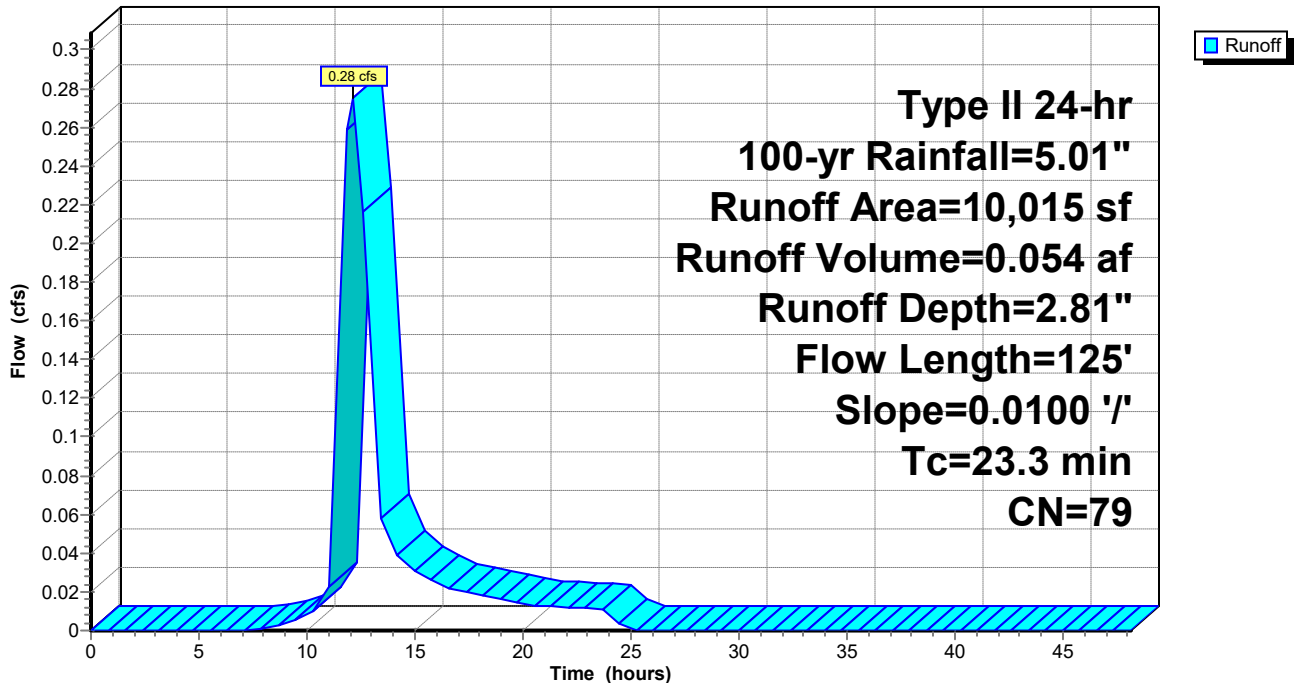

Plug Power - Proposed Conditions 5-15-21

Type II 24-hr 100-yr Rainfall=5.01"

Prepared by {enter your company name here}

Printed 5/20/2021

HydroCAD® 10.10-5a s/n 11585 © 2020 HydroCAD Software Solutions LLC

Page 16

Summary for Subcatchment 8S: Area Overland to North Prop. Line and Wetland Ditch (East)

Runoff = 1.77 cfs @ 11.91 hrs, Volume= 0.257 af, Depth= 2.63"

Runoff by SCS TR-20 method, UH=SCS, Weighted-CN, Time Span= 0.00-48.19 hrs, dt= 0.79 hrs
 Type II 24-hr 100-yr Rainfall=5.01"

Area (sf)	CN	Description
51,085	77	Brush, Fair, HSG D
51,085		100.00% Pervious Area

Tc (min)	Length (feet)	Slope (ft/ft)	Velocity (ft/sec)	Capacity (cfs)	Description
10.7	100	0.0200	0.16		Sheet Flow, 100' Overland Flow Range n= 0.130 P2= 2.14"
1.0	40	0.0100	0.70		Shallow Concentrated Flow, 40' Shallow Conc. Flow Short Grass Pasture Kv= 7.0 fps
11.7	140	Total			

Subcatchment 8S: Area Overland to North Prop. Line and Wetland Ditch (East)

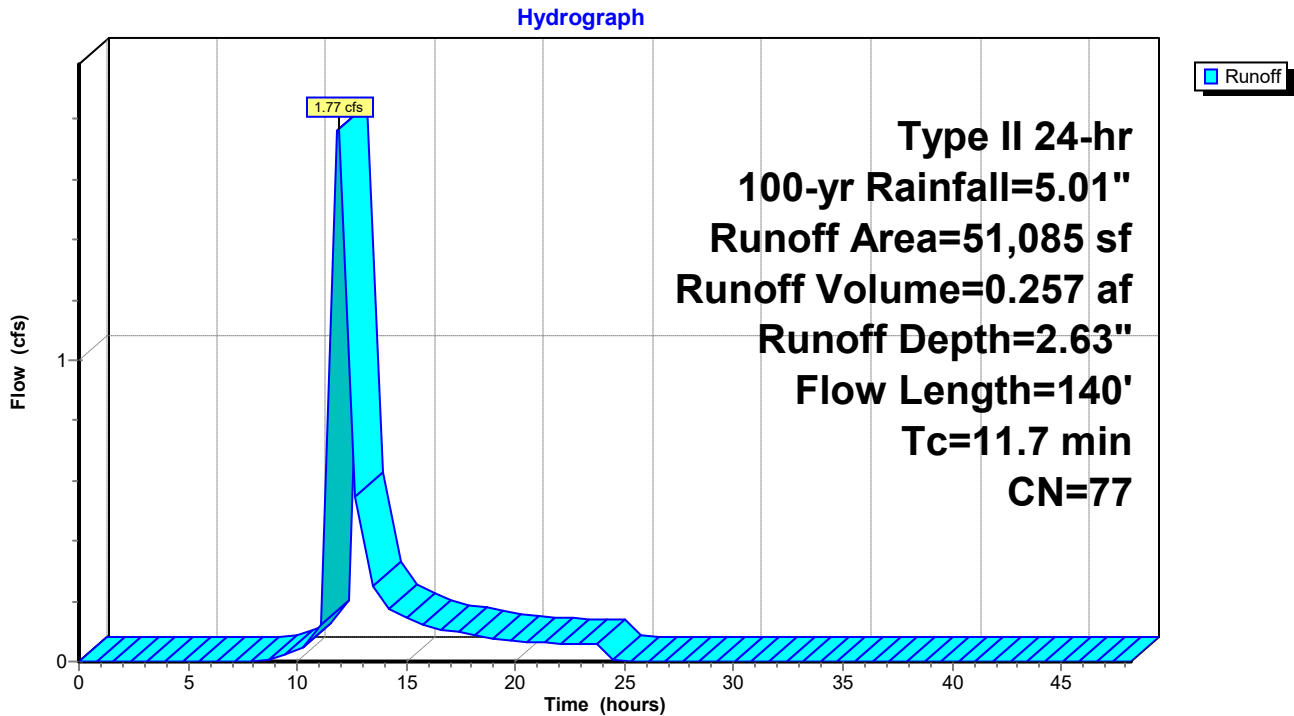

Plug Power - Proposed Conditions 5-15-21

Type II 24-hr 100-yr Rainfall=5.01"

Prepared by {enter your company name here}

Printed 5/20/2021

HydroCAD® 10.10-5a s/n 11585 © 2020 HydroCAD Software Solutions LLC

Page 17

Summary for Subcatchment 10S: Area to CB#1

Runoff = 1.02 cfs @ 11.89 hrs, Volume= 0.151 af, Depth= 4.10"

Runoff by SCS TR-20 method, UH=SCS, Weighted-CN, Time Span= 0.00-48.19 hrs, dt= 0.79 hrs
 Type II 24-hr 100-yr Rainfall=5.01"

Area (sf)	CN	Description
4,063	98	Roofs, HSG D
8,840	98	Paved parking, HSG D
6,337	80	>75% Grass cover, Good, HSG D
19,240	92	Weighted Average
6,337		32.94% Pervious Area
12,903		67.06% Impervious Area

Tc (min)	Length (feet)	Slope (ft/ft)	Velocity (ft/sec)	Capacity (cfs)	Description
12.4	65	0.0200	0.09		Sheet Flow, 65' Overland Flow Grass: Dense n= 0.240 P2= 2.14"
0.4	15	0.0100	0.58		Sheet Flow, 15' Overland Flow Smooth surfaces n= 0.011 P2= 2.14"
12.8	80	Total			

Subcatchment 10S: Area to CB#1

Hydrograph

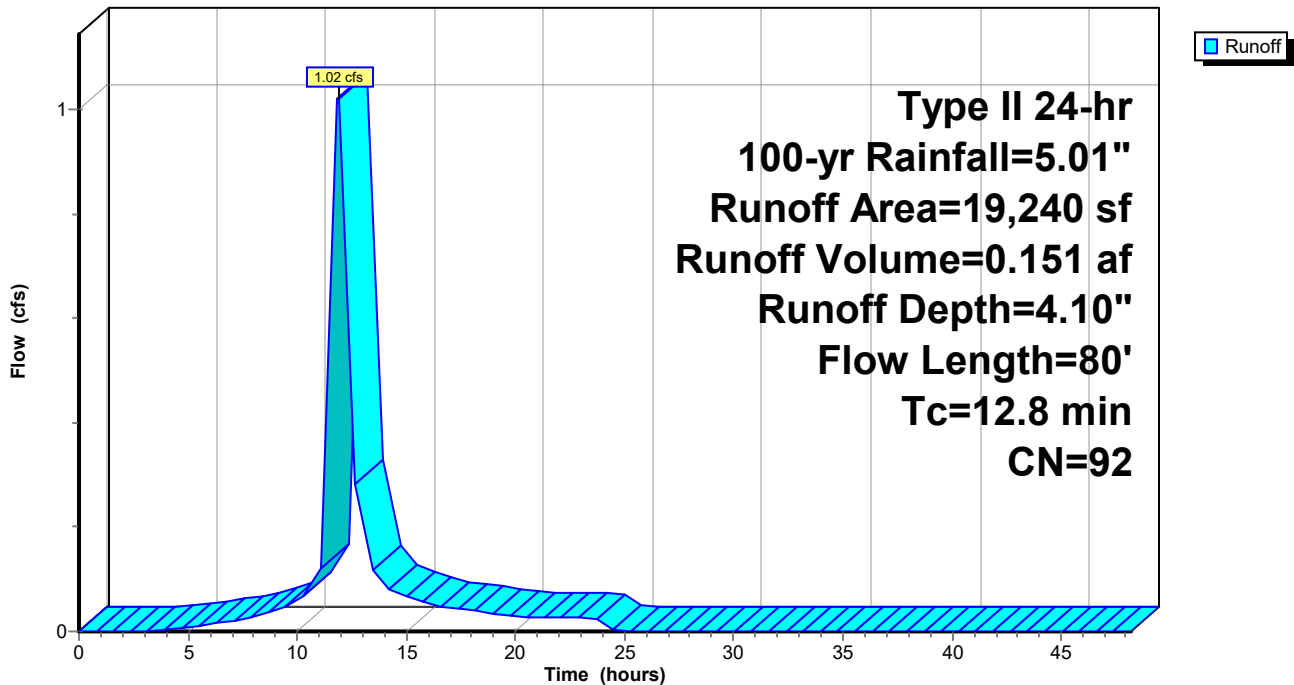

Plug Power - Proposed Conditions 5-15-21

Type II 24-hr 100-yr Rainfall=5.01"

Prepared by {enter your company name here}

Printed 5/20/2021

HydroCAD® 10.10-5a s/n 11585 © 2020 HydroCAD Software Solutions LLC

Page 18

Summary for Subcatchment 12S: Area to CB#2

Runoff = 0.61 cfs @ 11.89 hrs, Volume= 0.089 af, Depth= 3.78"

Runoff by SCS TR-20 method, UH=SCS, Weighted-CN, Time Span= 0.00-48.19 hrs, dt= 0.79 hrs
Type II 24-hr 100-yr Rainfall=5.01"

Area (sf)	CN	Description
4,063	98	Roofs, HSG D
1,800	98	Paved parking, HSG D
6,452	80	>75% Grass cover, Good, HSG D
12,315	89	Weighted Average
6,452		52.39% Pervious Area
5,863		47.61% Impervious Area

Tc (min)	Length (feet)	Slope (ft/ft)	Velocity (ft/sec)	Capacity (cfs)	Description
12.4	65	0.0200	0.09		Sheet Flow, 65' Overland Flow Grass: Dense n= 0.240 P2= 2.14"
0.4	15	0.0100	0.58		Sheet Flow, 15' Overland Flow Smooth surfaces n= 0.011 P2= 2.14"
12.8	80	Total			

Subcatchment 12S: Area to CB#2

Hydrograph

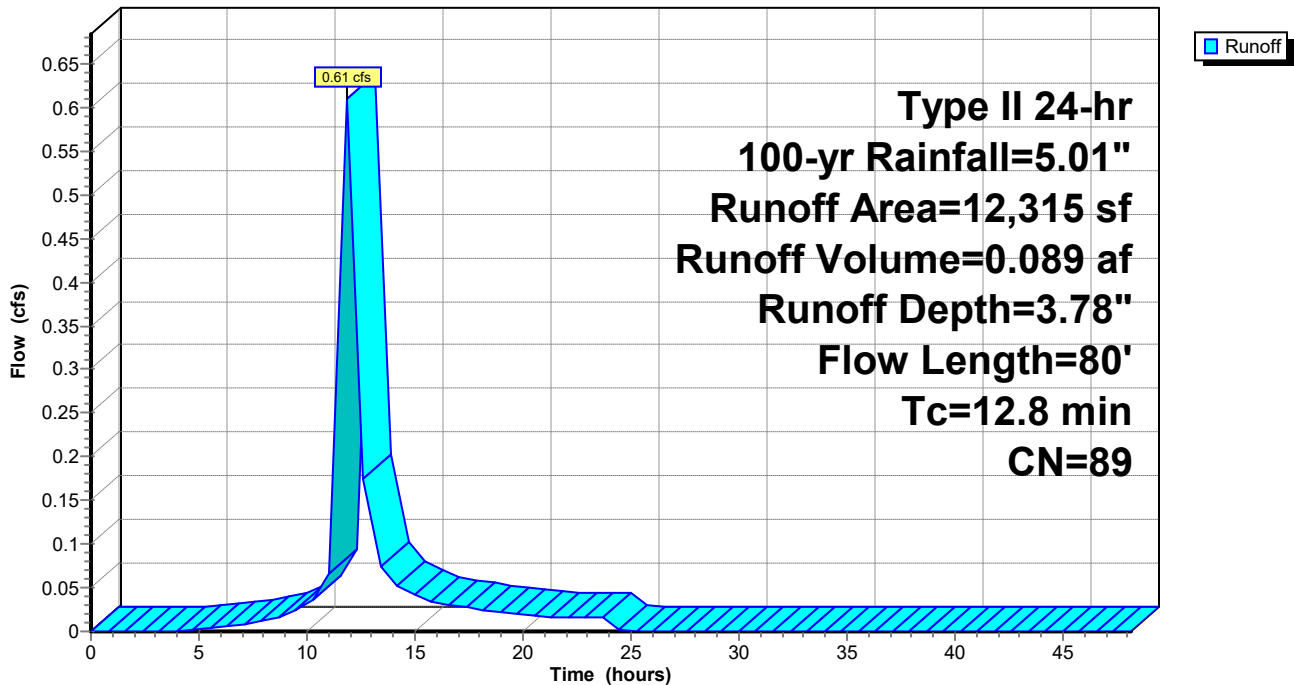

Plug Power - Proposed Conditions 5-15-21

Type II 24-hr 100-yr Rainfall=5.01"

Prepared by {enter your company name here}

Printed 5/20/2021

HydroCAD® 10.10-5a s/n 11585 © 2020 HydroCAD Software Solutions LLC

Page 19

Summary for Subcatchment 14S: Area to CB#3

Runoff = 0.76 cfs @ 11.96 hrs, Volume= 0.129 af, Depth= 3.68"

Runoff by SCS TR-20 method, UH=SCS, Weighted-CN, Time Span= 0.00-48.19 hrs, dt= 0.79 hrs
Type II 24-hr 100-yr Rainfall=5.01"

Area (sf)	CN	Description
8,620	98	Paved parking, HSG D
9,725	80	>75% Grass cover, Good, HSG D
18,345	88	Weighted Average
9,725		53.01% Pervious Area
8,620		46.99% Impervious Area

Tc (min)	Length (feet)	Slope (ft/ft)	Velocity (ft/sec)	Capacity (cfs)	Description
17.5	100	0.0200	0.10		Sheet Flow, 100' Overland Flow Grass: Dense n= 0.240 P2= 2.14"
1.4	130	0.0100	1.50		Shallow Concentrated Flow, 130' Shallow Conc. Flow Grassed Waterway Kv= 15.0 fps
0.2	30	0.0200	2.87		Shallow Concentrated Flow, 30' Shallow Conc. Flow Paved Kv= 20.3 fps
19.1	260	Total			

Subcatchment 14S: Area to CB#3

Hydrograph

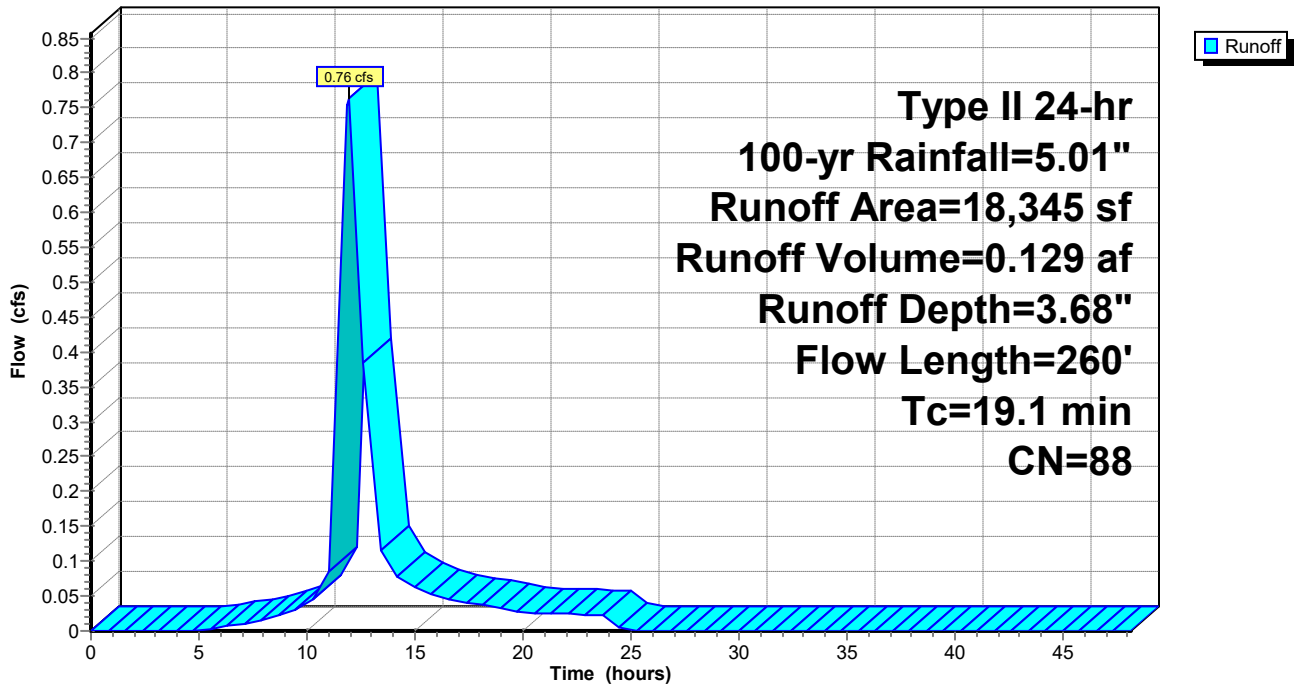

Plug Power - Proposed Conditions 5-15-21

Type II 24-hr 100-yr Rainfall=5.01"

Prepared by {enter your company name here}

Printed 5/20/2021

HydroCAD® 10.10-5a s/n 11585 © 2020 HydroCAD Software Solutions LLC

Page 20

Summary for Subcatchment 18S: Area to YD#2

Runoff = 0.83 cfs @ 12.11 hrs, Volume= 0.161 af, Depth= 3.09"

Runoff by SCS TR-20 method, UH=SCS, Weighted-CN, Time Span= 0.00-48.19 hrs, dt= 0.79 hrs
Type II 24-hr 100-yr Rainfall=5.01"

Area (sf)	CN	Adj	Description
19,675	80		>75% Grass cover, Good, HSG D
7,525	98		Unconnected pavement, HSG D
27,200	85	82	Weighted Average, UI Adjusted
19,675			72.33% Pervious Area
7,525			27.67% Impervious Area
7,525			100.00% Unconnected

Tc (min)	Length (feet)	Slope (ft/ft)	Velocity (ft/sec)	Capacity (cfs)	Description
23.0	100	0.0100	0.07		Sheet Flow, 100' Overland Flow Grass: Dense n= 0.240 P2= 2.14"
0.4	40	0.0100	1.50		Shallow Concentrated Flow, 40' Shallow Conc. Flow Grassed Waterway Kv= 15.0 fps
23.4	140	Total			

Subcatchment 18S: Area to YD#2

Hydrograph

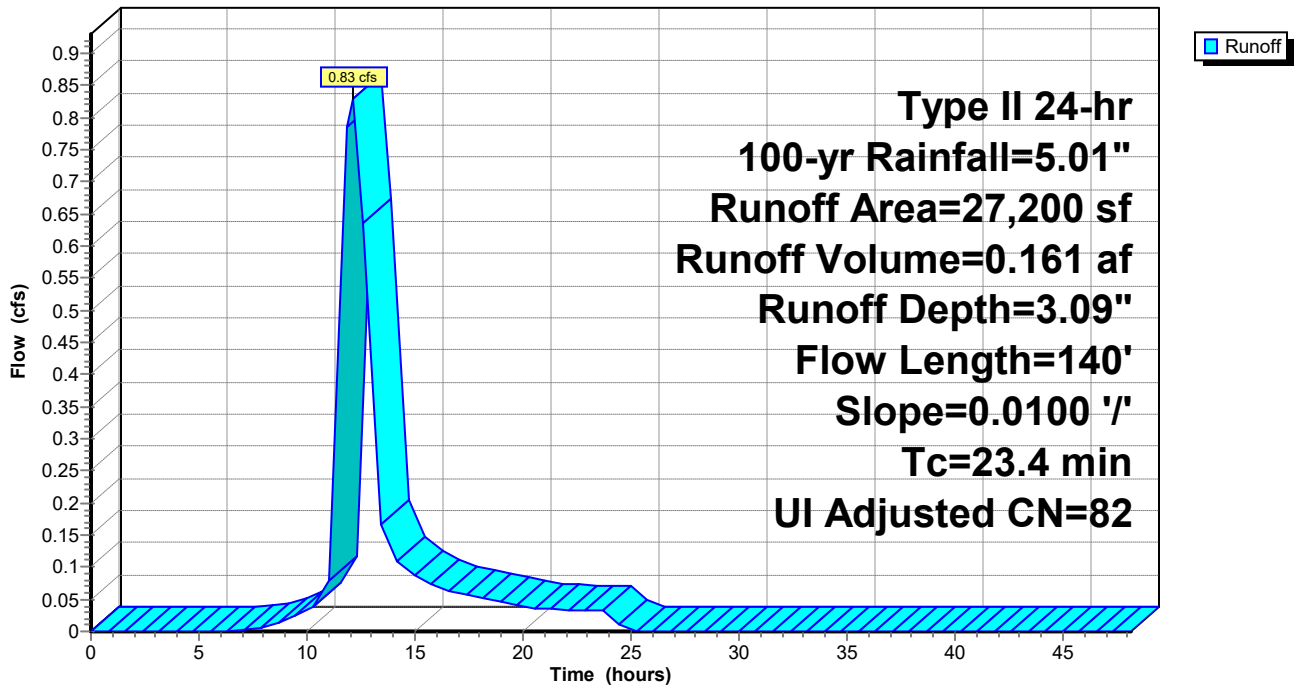

Plug Power - Proposed Conditions 5-15-21

Type II 24-hr 100-yr Rainfall=5.01"

Prepared by {enter your company name here}

Printed 5/20/2021

HydroCAD® 10.10-5a s/n 11585 © 2020 HydroCAD Software Solutions LLC

Page 21

Summary for Subcatchment 20S: Eastern Area Overland to Gravel Storage

Runoff = 12.36 cfs @ 12.40 hrs, Volume= 2.515 af, Depth= 3.99"

Runoff by SCS TR-20 method, UH=SCS, Weighted-CN, Time Span= 0.00-48.19 hrs, dt= 0.79 hrs
 Type II 24-hr 100-yr Rainfall=5.01"

Area (sf)	CN	Description
* 77,480	80	Gravel Storage Area, Good, HSG D
80,190	98	Paved parking, HSG D
77,985	98	Roofs, HSG D
47,575	98	Unconnected pavement, HSG D
46,080	80	>75% Grass cover, Good, HSG D
329,310	91	Weighted Average
123,560		37.52% Pervious Area
205,750		62.48% Impervious Area
47,575		23.12% Unconnected

Tc (min)	Length (feet)	Slope (ft/ft)	Velocity (ft/sec)	Capacity (cfs)	Description
16.5	75	0.0130	0.08		Sheet Flow, 75' Overland Flow Grass: Dense n= 0.240 P2= 2.14"
12.3	25	0.0030	0.03		Sheet Flow, 25' Overland Flow Grass: Dense n= 0.240 P2= 2.14"
0.2	30	0.0300	2.60		Shallow Concentrated Flow, 30' Shallow Conc. Flow Grassed Waterway Kv= 15.0 fps
1.2	200	0.0200	2.87		Shallow Concentrated Flow, 200' Shallow Conc. Flow Paved Kv= 20.3 fps
30.2	330	Total			

Subcatchment 20S: Eastern Area Overland to Gravel Storage

Hydrograph

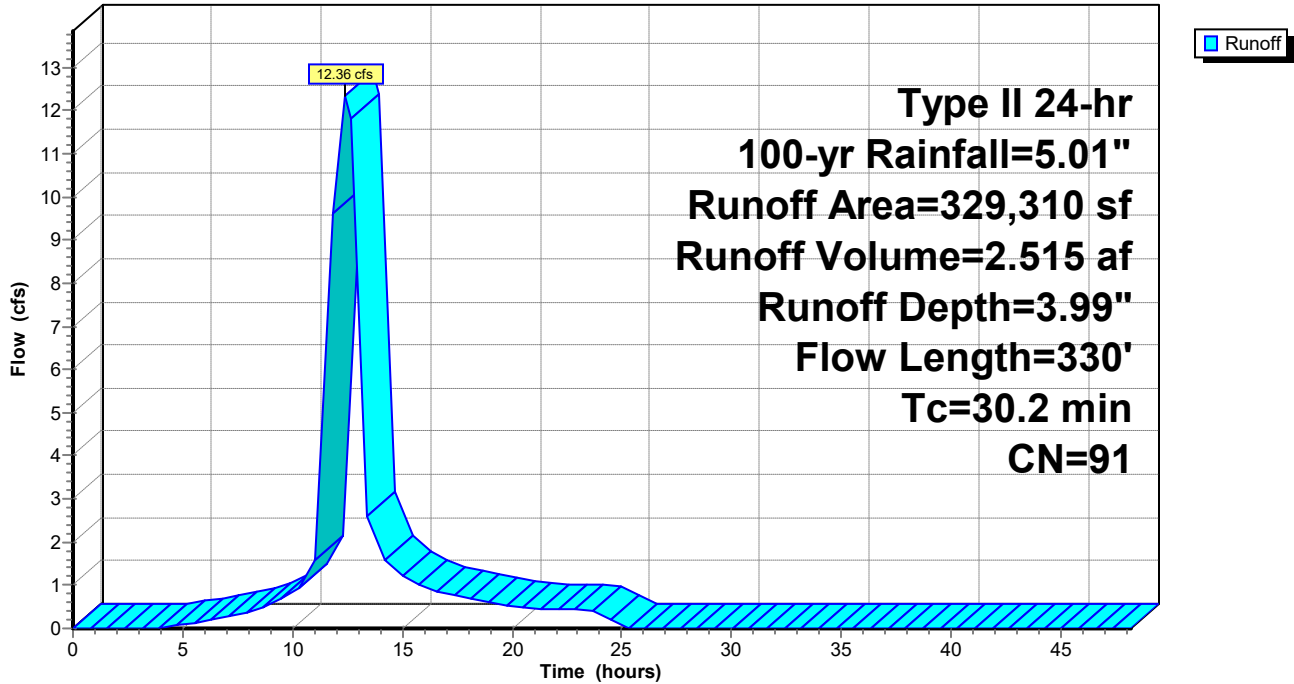

Plug Power - Proposed Conditions 5-15-21

Type II 24-hr 100-yr Rainfall=5.01"

Prepared by {enter your company name here}

Printed 5/20/2021

HydroCAD® 10.10-5a s/n 11585 © 2020 HydroCAD Software Solutions LLC

Page 23

Summary for Subcatchment 24S: Area to YD#11

Runoff = 1.79 cfs @ 11.93 hrs, Volume= 0.289 af, Depth= 3.89"

Runoff by SCS TR-20 method, UH=SCS, Weighted-CN, Time Span= 0.00-48.19 hrs, dt= 0.79 hrs
Type II 24-hr 100-yr Rainfall=5.01"

Area (sf)	CN	Description
3,925	98	Paved parking, HSG D
17,935	80	>75% Grass cover, Good, HSG D
17,040	98	Roofs, HSG D
38,900	90	Weighted Average
17,935		46.11% Pervious Area
20,965		53.89% Impervious Area

Tc (min)	Length (feet)	Slope (ft/ft)	Velocity (ft/sec)	Capacity (cfs)	Description
17.3	70	0.0100	0.07		Sheet Flow, 70' Overland Flow Grass: Dense n= 0.240 P2= 2.14"

Subcatchment 24S: Area to YD#11

Hydrograph

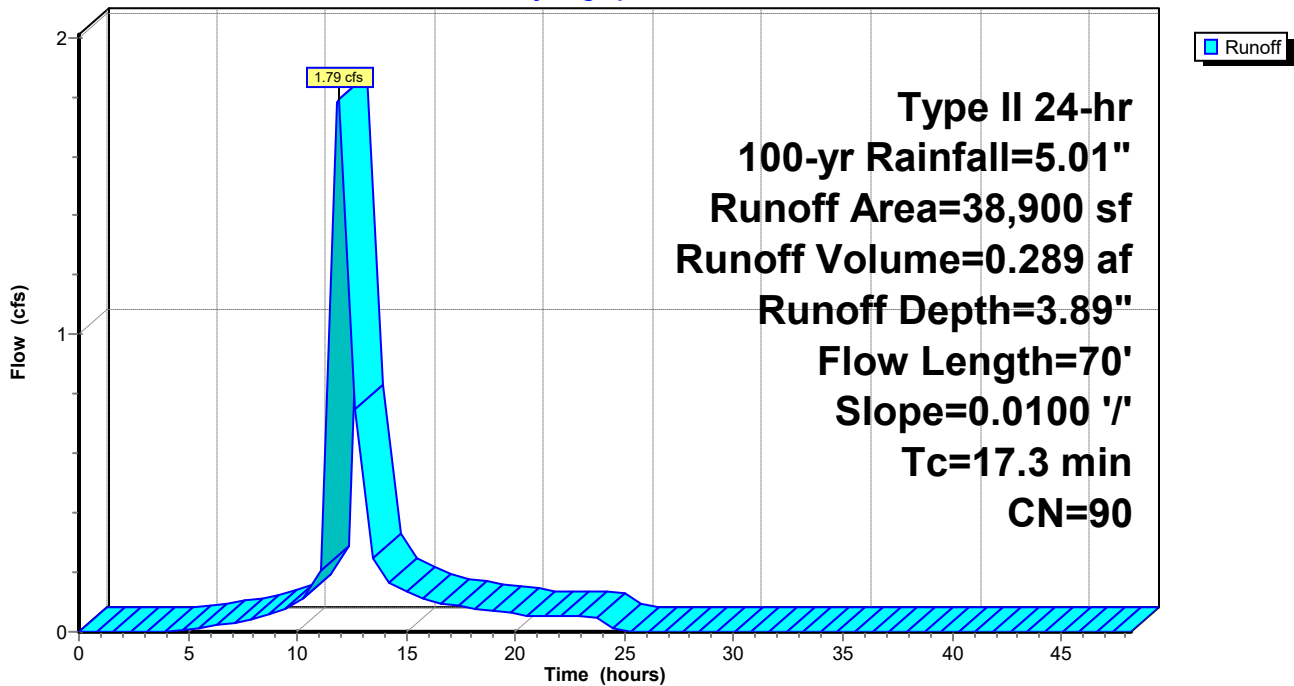

Plug Power - Proposed Conditions 5-15-21

Type II 24-hr 100-yr Rainfall=5.01"

Prepared by {enter your company name here}

Printed 5/20/2021

HydroCAD® 10.10-5a s/n 11585 © 2020 HydroCAD Software Solutions LLC

Page 24

Summary for Subcatchment 26S: Area to CB#4

Runoff = 1.97 cfs @ 11.93 hrs, Volume= 0.315 af, Depth= 3.99"

Runoff by SCS TR-20 method, UH=SCS, Weighted-CN, Time Span= 0.00-48.19 hrs, dt= 0.79 hrs
Type II 24-hr 100-yr Rainfall=5.01"

Area (sf)	CN	Description
510	98	Roofs, HSG D
25,120	98	Paved parking, HSG D
15,575	80	>75% Grass cover, Good, HSG D
41,205	91	Weighted Average
15,575		37.80% Pervious Area
25,630		62.20% Impervious Area

Tc (min)	Length (feet)	Slope (ft/ft)	Velocity (ft/sec)	Capacity (cfs)	Description
16.3	65	0.0100	0.07		Sheet Flow, 65' Overland Flow Grass: Dense n= 0.240 P2= 2.14"
0.6	35	0.0200	0.91		Sheet Flow, 35' Overland Flow Smooth surfaces n= 0.011 P2= 2.14"
16.9	100	Total			

Subcatchment 26S: Area to CB#4

Hydrograph

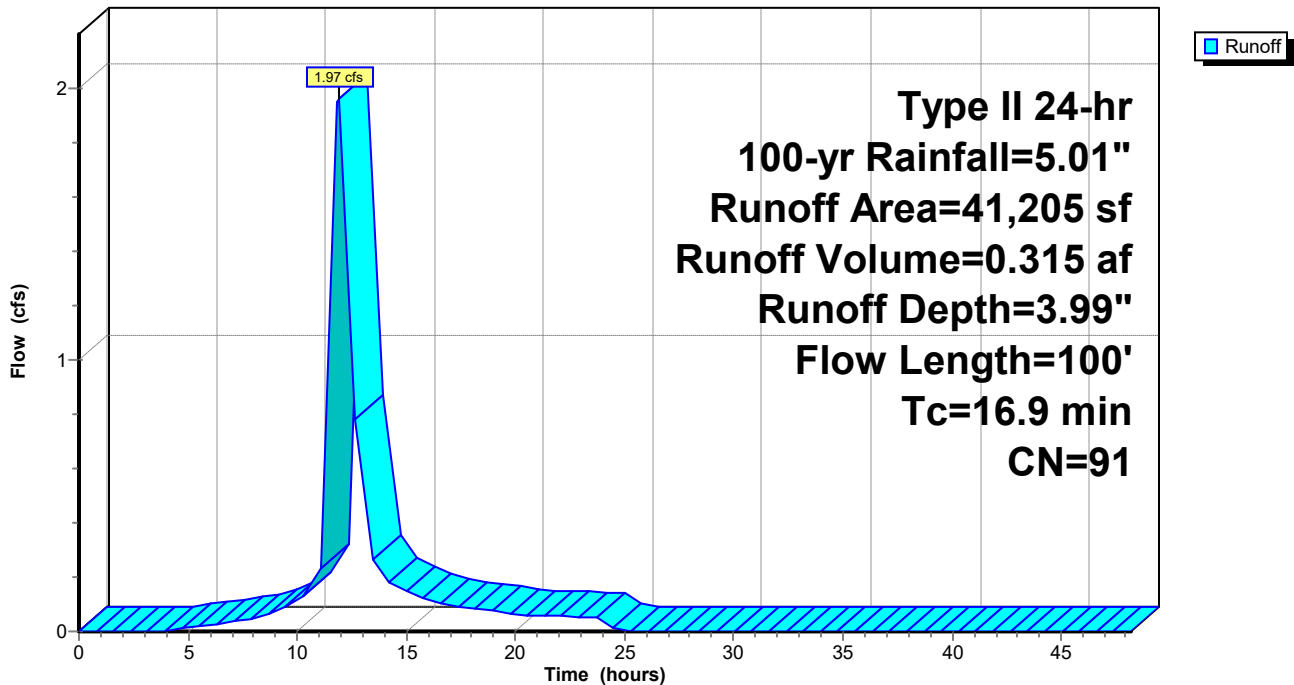

Plug Power - Proposed Conditions 5-15-21

Type II 24-hr 100-yr Rainfall=5.01"

Prepared by {enter your company name here}

Printed 5/20/2021

HydroCAD® 10.10-5a s/n 11585 © 2020 HydroCAD Software Solutions LLC

Page 25

Summary for Subcatchment 29S: Area to CB#15

Runoff = 1.05 cfs @ 11.86 hrs, Volume= 0.156 af, Depth= 4.77"

Runoff by SCS TR-20 method, UH=SCS, Weighted-CN, Time Span= 0.00-48.19 hrs, dt= 0.79 hrs
Type II 24-hr 100-yr Rainfall=5.01"

Area (sf)	CN	Description
17,040	98	Roofs, HSG D
17,040		100.00% Impervious Area

Tc (min)	Length (feet)	Slope (ft/ft)	Velocity (ft/sec)	Capacity (cfs)	Description
5.0					Direct Entry,

Subcatchment 29S: Area to CB#15

Hydrograph

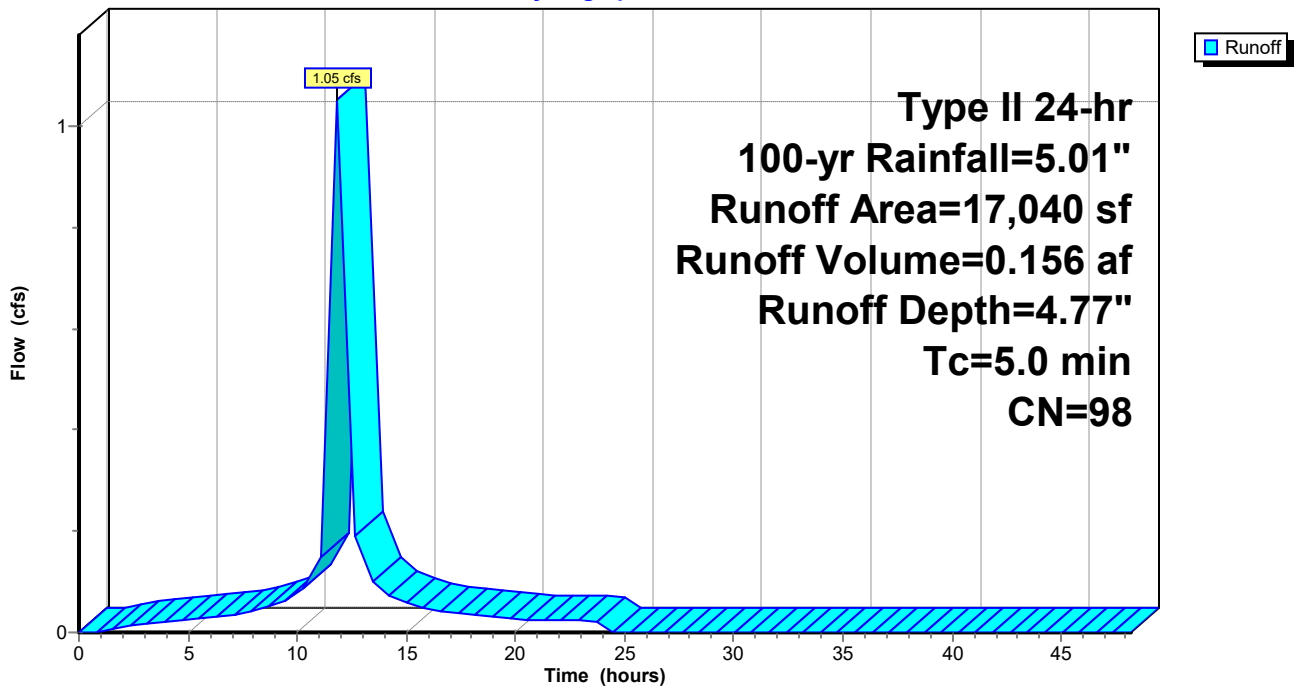

Plug Power - Proposed Conditions 5-15-21

Type II 24-hr 100-yr Rainfall=5.01"

Prepared by {enter your company name here}

Printed 5/20/2021

HydroCAD® 10.10-5a s/n 11585 © 2020 HydroCAD Software Solutions LLC

Page 26

Summary for Subcatchment 30S: Area to CB#18

Runoff = 0.59 cfs @ 12.11 hrs, Volume= 0.115 af, Depth= 2.99"

Runoff by SCS TR-20 method, UH=SCS, Weighted-CN, Time Span= 0.00-48.19 hrs, dt= 0.79 hrs
Type II 24-hr 100-yr Rainfall=5.01"

Area (sf)	CN	Adj	Description
3,025	98		Unconnected pavement, HSG D
17,075	80		>75% Grass cover, Good, HSG D
20,100	83	81	Weighted Average, UI Adjusted
17,075			84.95% Pervious Area
3,025			15.05% Impervious Area
3,025			100.00% Unconnected

Tc (min)	Length (feet)	Slope (ft/ft)	Velocity (ft/sec)	Capacity (cfs)	Description
23.0	100	0.0100	0.07		Sheet Flow, 100' Overland Flow
					Grass: Dense n= 0.240 P2= 2.14"
0.4	40	0.0100	1.50		Shallow Concentrated Flow, 40' Shallow Conc. Flow
					Grassed Waterway Kv= 15.0 fps
23.4	140	Total			

Subcatchment 30S: Area to CB#18

Hydrograph

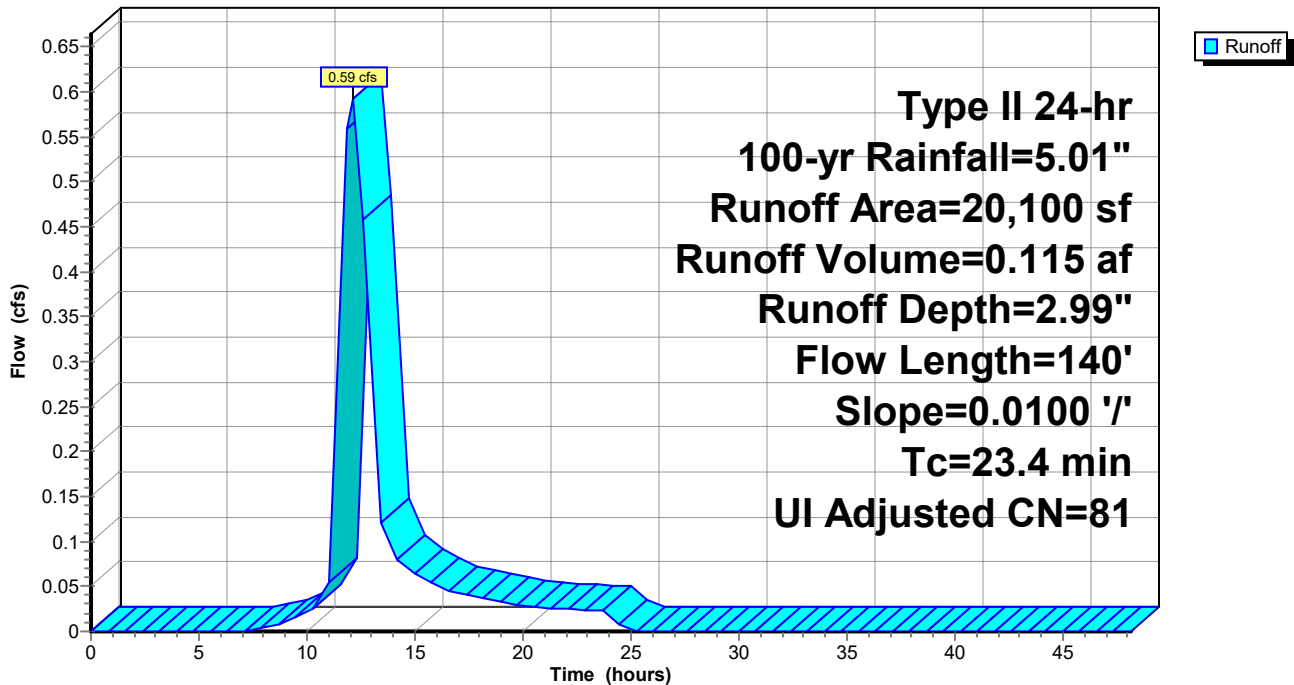

Plug Power - Proposed Conditions 5-15-21

Type II 24-hr 100-yr Rainfall=5.01"

Prepared by {enter your company name here}

Printed 5/20/2021

HydroCAD® 10.10-5a s/n 11585 © 2020 HydroCAD Software Solutions LLC

Page 27

Summary for Subcatchment 32S: Area to CB#7

Runoff = 1.77 cfs @ 11.92 hrs, Volume= 0.284 af, Depth= 4.10"

Runoff by SCS TR-20 method, UH=SCS, Weighted-CN, Time Span= 0.00-48.19 hrs, dt= 0.79 hrs
Type II 24-hr 100-yr Rainfall=5.01"

Area (sf)	CN	Description
25,120	98	Paved parking, HSG D
11,100	80	>75% Grass cover, Good, HSG D
36,220	92	Weighted Average
11,100		30.65% Pervious Area
25,120		69.35% Impervious Area

Tc (min)	Length (feet)	Slope (ft/ft)	Velocity (ft/sec)	Capacity (cfs)	Description
16.3	65	0.0100	0.07		Sheet Flow, 65' Overland Flow Grass: Dense n= 0.240 P2= 2.14"
0.6	35	0.0200	0.91		Sheet Flow, 35' Overland Flow Smooth surfaces n= 0.011 P2= 2.14"
16.9	100	Total			

Subcatchment 32S: Area to CB#7

Hydrograph

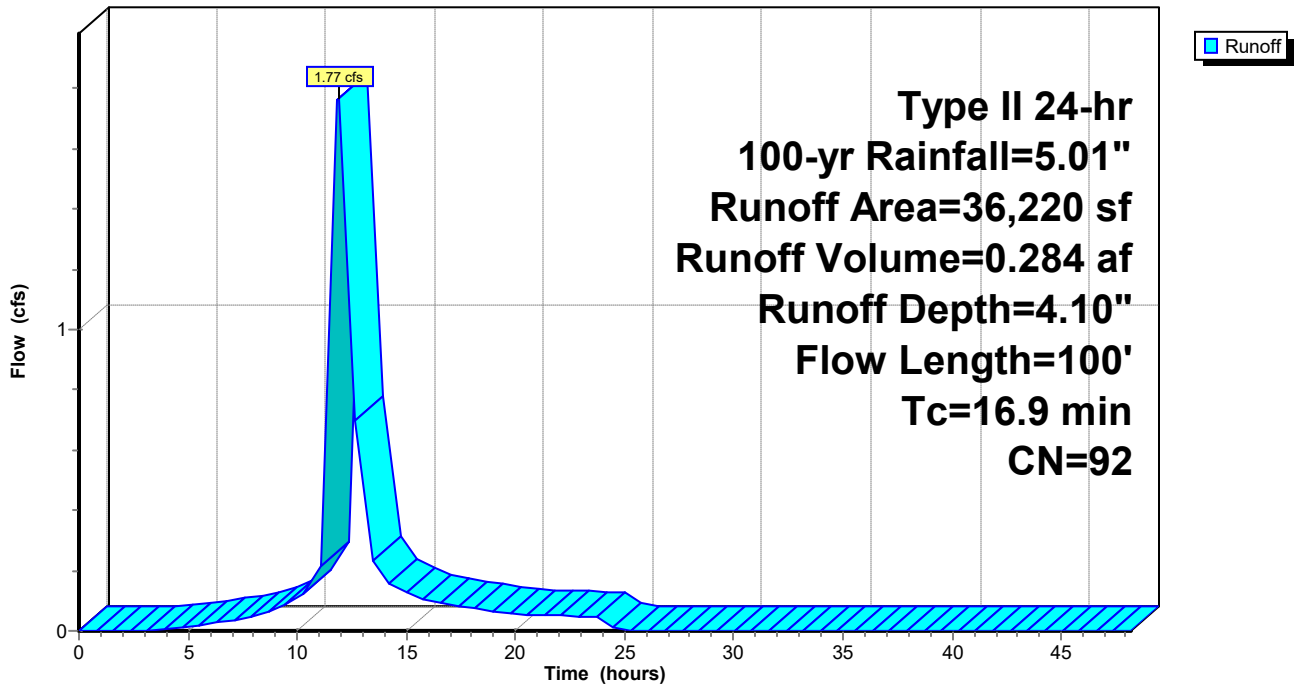

Plug Power - Proposed Conditions 5-15-21

Type II 24-hr 100-yr Rainfall=5.01"

Prepared by {enter your company name here}

Printed 5/20/2021

HydroCAD® 10.10-5a s/n 11585 © 2020 HydroCAD Software Solutions LLC

Page 28

Summary for Subcatchment 36S: Area to CB#9

Runoff = 0.77 cfs @ 11.97 hrs, Volume= 0.130 af, Depth= 3.68"

Runoff by SCS TR-20 method, UH=SCS, Weighted-CN, Time Span= 0.00-48.19 hrs, dt= 0.79 hrs
Type II 24-hr 100-yr Rainfall=5.01"

Area (sf)	CN	Description
5,755	98	Paved parking, HSG D
2,520	98	Unconnected pavement, HSG D
10,200	80	>75% Grass cover, Good, HSG D
18,475	88	Weighted Average
10,200		55.21% Pervious Area
8,275		44.79% Impervious Area
2,520		30.45% Unconnected

Tc (min)	Length (feet)	Slope (ft/ft)	Velocity (ft/sec)	Capacity (cfs)	Description
19.3	80	0.0100	0.07		Sheet Flow, 80' Overland Flow Grass: Dense n= 0.240 P2= 2.14"

Subcatchment 36S: Area to CB#9

Hydrograph

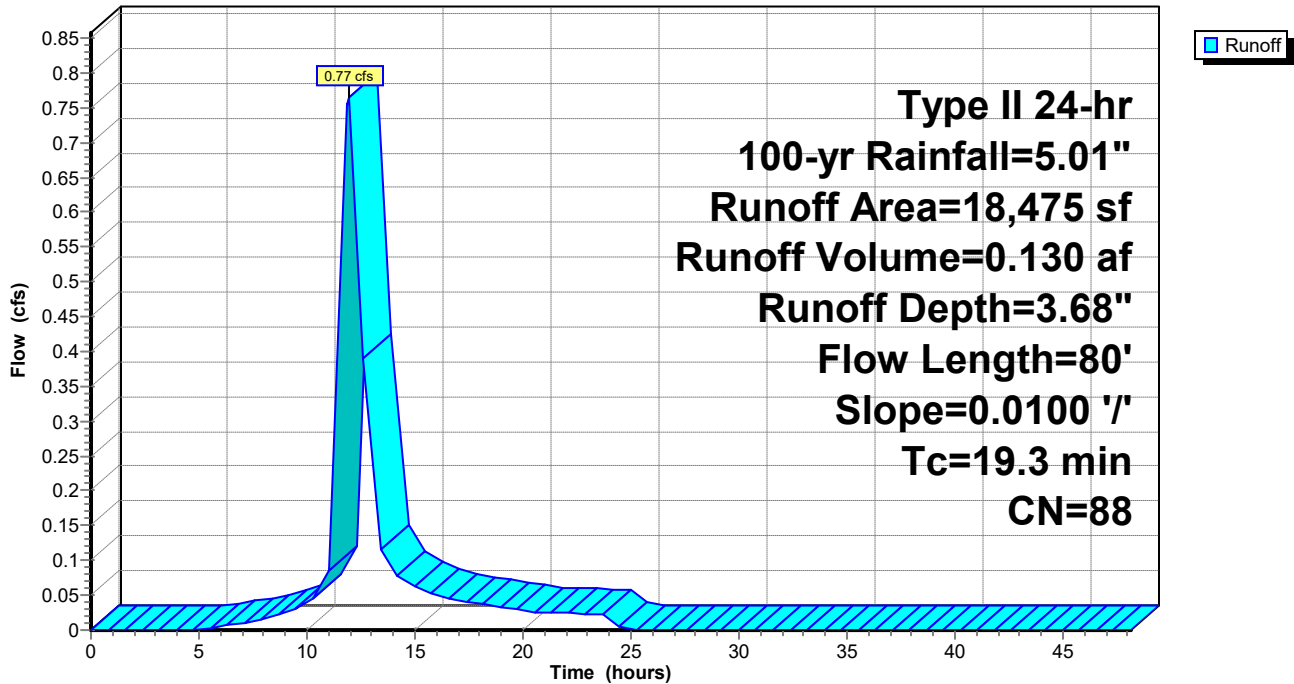

Plug Power - Proposed Conditions 5-15-21

Type II 24-hr 100-yr Rainfall=5.01"

Prepared by {enter your company name here}

Printed 5/20/2021

HydroCAD® 10.10-5a s/n 11585 © 2020 HydroCAD Software Solutions LLC

Page 29

Summary for Subcatchment 38S: Area to CB#10

Runoff = 1.36 cfs @ 12.01 hrs, Volume= 0.241 af, Depth= 3.18"

Runoff by SCS TR-20 method, UH=SCS, Weighted-CN, Time Span= 0.00-48.19 hrs, dt= 0.79 hrs
Type II 24-hr 100-yr Rainfall=5.01"

Area (sf)	CN	Description
8,155	79	Woods, Fair, HSG D
5,920	78	Meadow, non-grazed, HSG D
6,730	98	Paved parking, HSG D
18,845	80	>75% Grass cover, Good, HSG D
39,650	83	Weighted Average
32,920		83.03% Pervious Area
6,730		16.97% Impervious Area

Tc (min)	Length (feet)	Slope (ft/ft)	Velocity (ft/sec)	Capacity (cfs)	Description
20.1	100	0.0140	0.08		Sheet Flow, 100' Overland Flow Grass: Dense n= 0.240 P2= 2.14"
0.5	50	0.0140	1.77		Shallow Concentrated Flow, 50' Shallow Conc. Flow Grassed Waterway Kv= 15.0 fps
20.6	150	Total			

Subcatchment 38S: Area to CB#10

Hydrograph

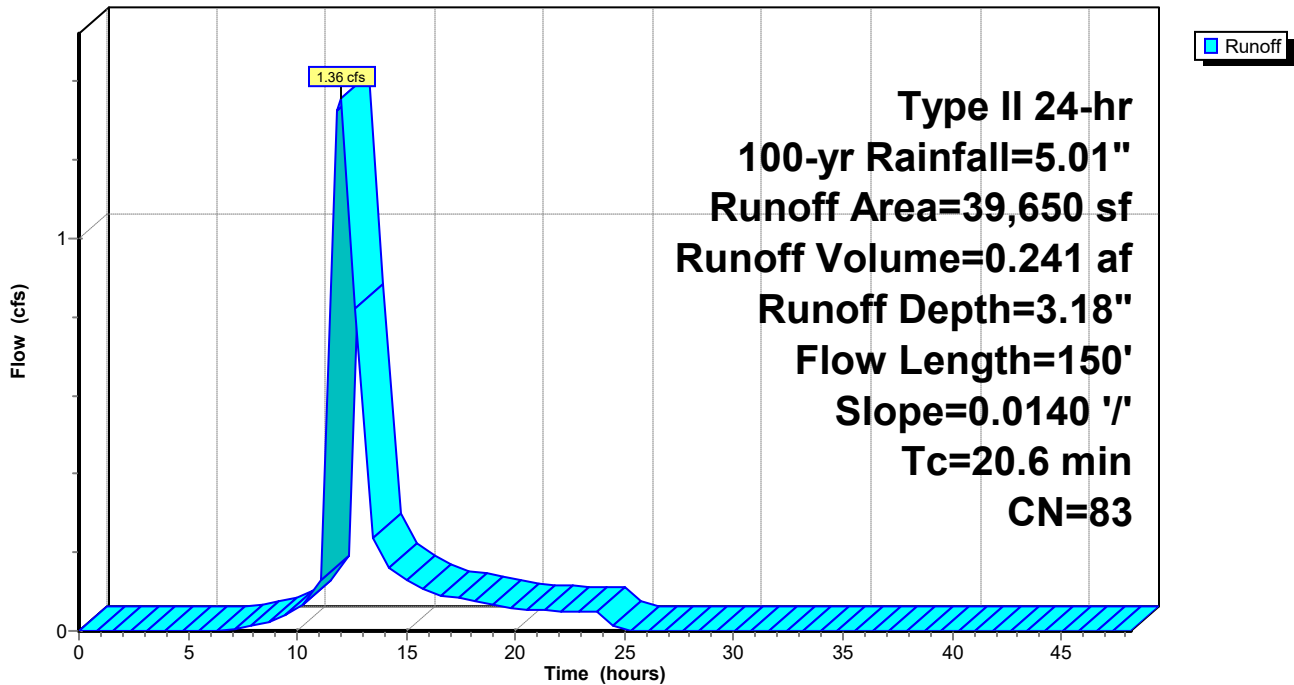

Plug Power - Proposed Conditions 5-15-21

Type II 24-hr 100-yr Rainfall=5.01"

Prepared by {enter your company name here}

Printed 5/20/2021

HydroCAD® 10.10-5a s/n 11585 © 2020 HydroCAD Software Solutions LLC

Page 30

Summary for Subcatchment 40S: Area to CB#11

Runoff = 1.47 cfs @ 12.00 hrs, Volume= 0.288 af, Depth= 4.77"

Runoff by SCS TR-20 method, UH=SCS, Weighted-CN, Time Span= 0.00-48.19 hrs, dt= 0.79 hrs
Type II 24-hr 100-yr Rainfall=5.01"

Area (sf)	CN	Description
4,960	98	Paved parking, HSG D
26,535	98	Paved parking, HSG D
31,495	98	Weighted Average
31,495		100.00% Impervious Area

Tc (min)	Length (feet)	Slope (ft/ft)	Velocity (ft/sec)	Capacity (cfs)	Description
21.4	100	0.0120	0.08		Sheet Flow, 100' Overland Flow Grass: Dense n= 0.240 P2= 2.14"
0.7	70	0.0120	1.64		Shallow Concentrated Flow, 70' Shallow Conc. Flow Grassed Waterway Kv= 15.0 fps
22.1	170	Total			

Subcatchment 40S: Area to CB#11

Hydrograph

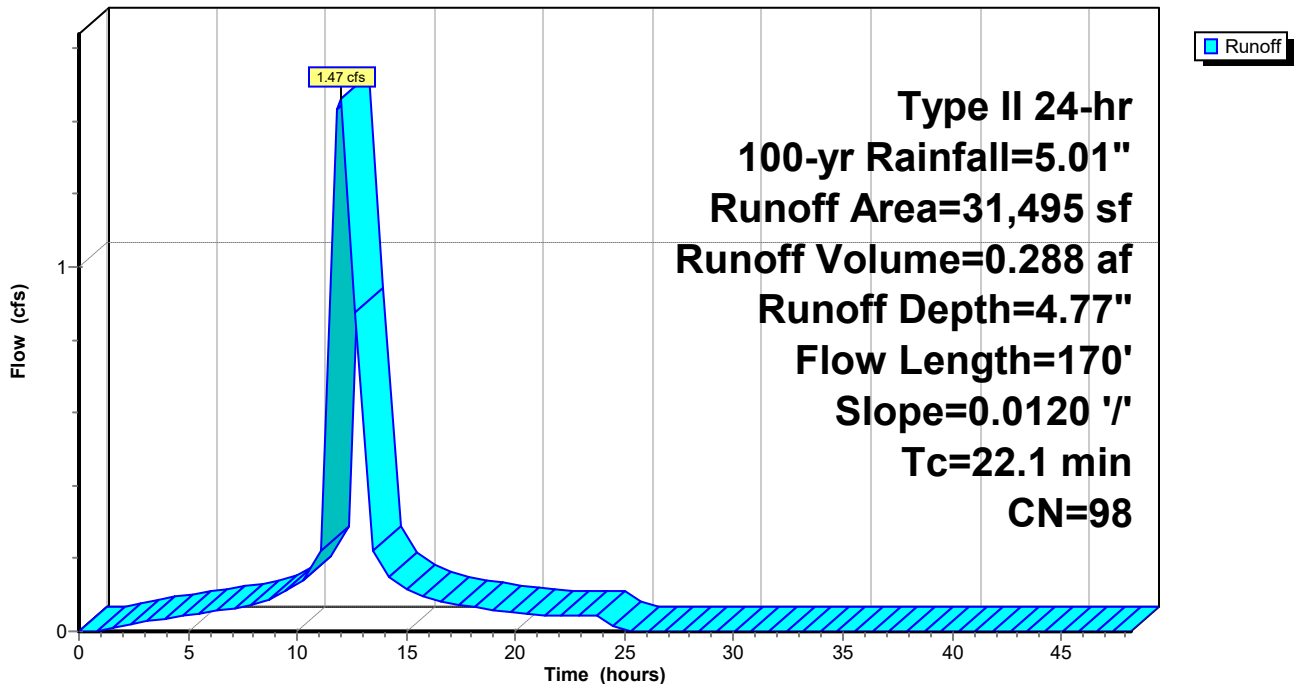

Plug Power - Proposed Conditions 5-15-21

Type II 24-hr 100-yr Rainfall=5.01"

Prepared by {enter your company name here}

Printed 5/20/2021

HydroCAD® 10.10-5a s/n 11585 © 2020 HydroCAD Software Solutions LLC

Page 31

Summary for Subcatchment 42S: Western Area Overland to Gravel Storage

Runoff = 7.21 cfs @ 11.87 hrs, Volume= 0.983 af, Depth= 3.68"

Runoff by SCS TR-20 method, UH=SCS, Weighted-CN, Time Span= 0.00-48.19 hrs, dt= 0.79 hrs
Type II 24-hr 100-yr Rainfall=5.01"

Area (sf)	CN	Description
* 53,390	80	Gravel Storage Area, Good, HSG D
31,080	98	Paved parking, HSG D
2,460	98	Unconnected pavement, HSG D
26,630	80	>75% Grass cover, Good, HSG D
26,105	98	Roofs, HSG D
139,665	88	Weighted Average
80,020		57.29% Pervious Area
59,645		42.71% Impervious Area
2,460		4.12% Unconnected

Tc (min)	Length (feet)	Slope (ft/ft)	Velocity (ft/sec)	Capacity (cfs)	Description
5.8	25	0.0200	0.07		Sheet Flow, 25' Overland Flow Grass: Dense n= 0.240 P2= 2.14"
0.5	25	0.0200	0.85		Sheet Flow, 25' Overland Flow Smooth surfaces n= 0.011 P2= 2.14"
6.3	50	Total			

Subcatchment 42S: Western Area Overland to Gravel Storage

Hydrograph

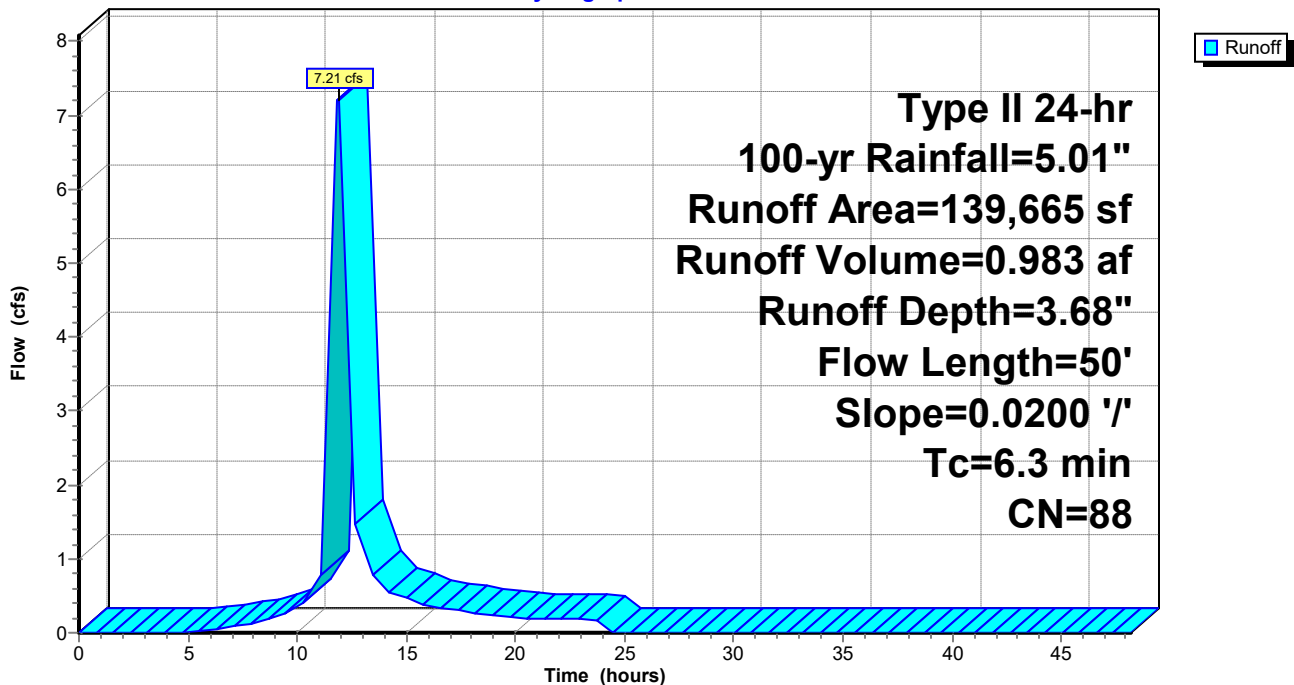

Plug Power - Proposed Conditions 5-15-21

Type II 24-hr 100-yr Rainfall=5.01"

Prepared by {enter your company name here}

Printed 5/20/2021

HydroCAD® 10.10-5a s/n 11585 © 2020 HydroCAD Software Solutions LLC

Page 32

Summary for Subcatchment 43S: North Half of Phase 2 Building

Runoff = 2.26 cfs @ 11.86 hrs, Volume= 0.333 af, Depth= 4.77"

Runoff by SCS TR-20 method, UH=SCS, Weighted-CN, Time Span= 0.00-48.19 hrs, dt= 0.79 hrs
Type II 24-hr 100-yr Rainfall=5.01"

Area (sf)	CN	Description
36,505	98	Roofs, HSG D
36,505		100.00% Impervious Area

Tc (min)	Length (feet)	Slope (ft/ft)	Velocity (ft/sec)	Capacity (cfs)	Description
5.0					Direct Entry,

Subcatchment 43S: North Half of Phase 2 Building

Hydrograph

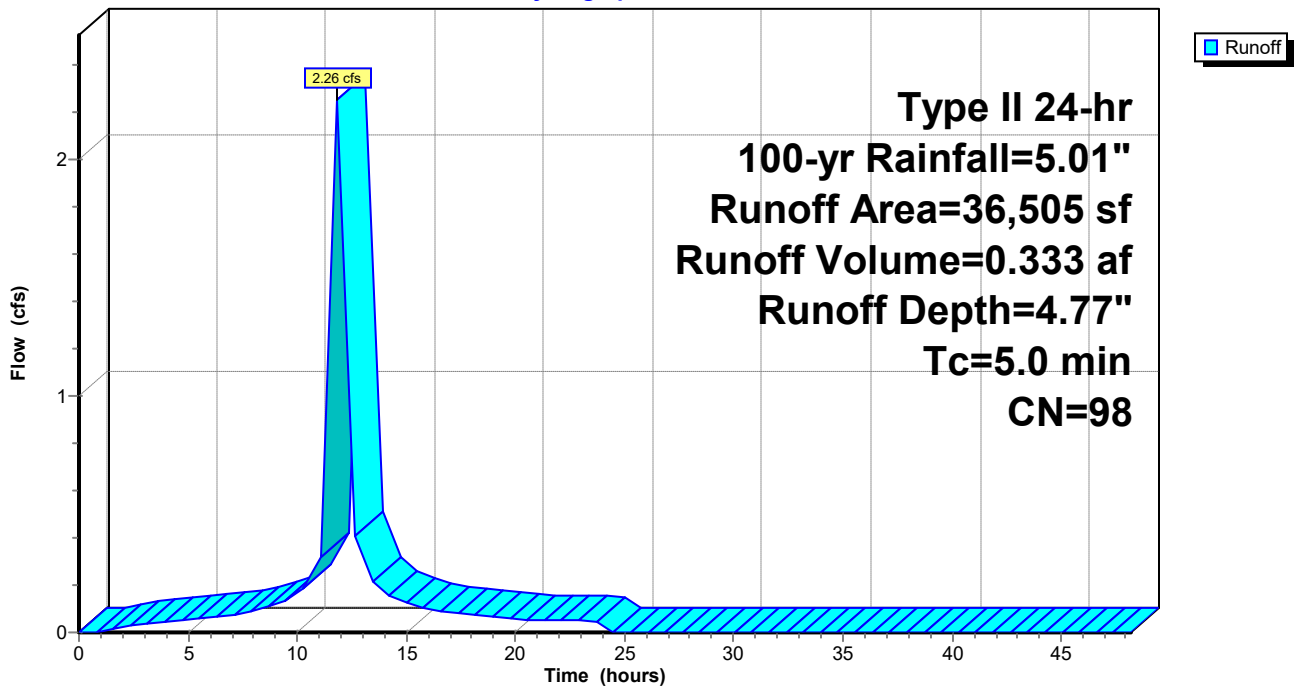

Plug Power - Proposed Conditions 5-15-21

Type II 24-hr 100-yr Rainfall=5.01"

Prepared by {enter your company name here}

Printed 5/20/2021

HydroCAD® 10.10-5a s/n 11585 © 2020 HydroCAD Software Solutions LLC

Page 33

Summary for Subcatchment 45S: South Half of Phase 2 Building

Runoff = 2.00 cfs @ 11.86 hrs, Volume= 0.295 af, Depth= 4.77"

Runoff by SCS TR-20 method, UH=SCS, Weighted-CN, Time Span= 0.00-48.19 hrs, dt= 0.79 hrs
Type II 24-hr 100-yr Rainfall=5.01"

Area (sf)	CN	Description
32,290	98	Roofs, HSG D
32,290		100.00% Impervious Area

Tc (min)	Length (feet)	Slope (ft/ft)	Velocity (ft/sec)	Capacity (cfs)	Description
5.0					Direct Entry,

Subcatchment 45S: South Half of Phase 2 Building

Hydrograph

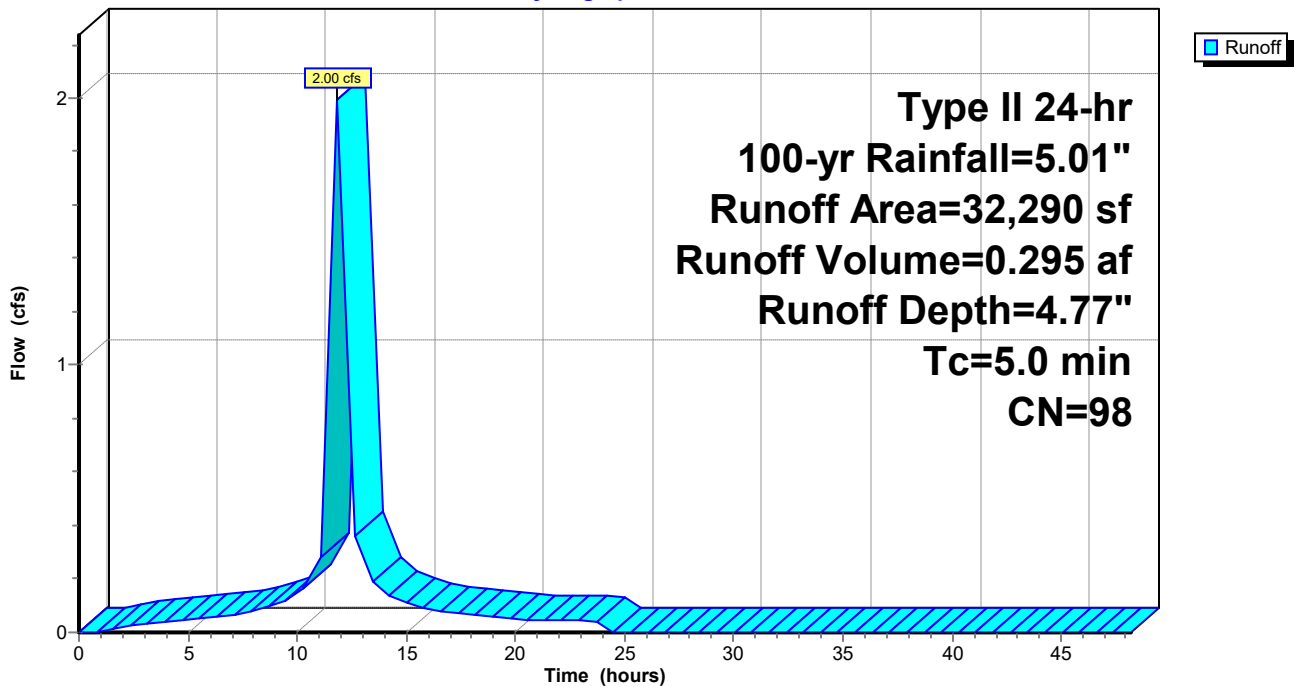

Plug Power - Proposed Conditions 5-15-21

Type II 24-hr 100-yr Rainfall=5.01"

Prepared by {enter your company name here}

Printed 5/20/2021

HydroCAD® 10.10-5a s/n 11585 © 2020 HydroCAD Software Solutions LLC

Page 34

Summary for Subcatchment 48S: Area to YD#1

Runoff = 1.21 cfs @ 12.08 hrs, Volume= 0.233 af, Depth= 3.58"

Runoff by SCS TR-20 method, UH=SCS, Weighted-CN, Time Span= 0.00-48.19 hrs, dt= 0.79 hrs
Type II 24-hr 100-yr Rainfall=5.01"

Area (sf)	CN	Description
2,610	98	Roofs, HSG D
21,165	80	>75% Grass cover, Good, HSG D
10,255	98	Paved parking, HSG D
34,030	87	Weighted Average
21,165		62.20% Pervious Area
12,865		37.80% Impervious Area

Tc (min)	Length (feet)	Slope (ft/ft)	Velocity (ft/sec)	Capacity (cfs)	Description
23.0	100	0.0100	0.07		Sheet Flow, 100' Overland Flow
					Grass: Dense n= 0.240 P2= 2.14"
0.6	50	0.0100	1.50		Shallow Concentrated Flow, 50' Shallow Conc. Flow
					Grassed Waterway Kv= 15.0 fps
23.6	150	Total			

Subcatchment 48S: Area to YD#1

Hydrograph

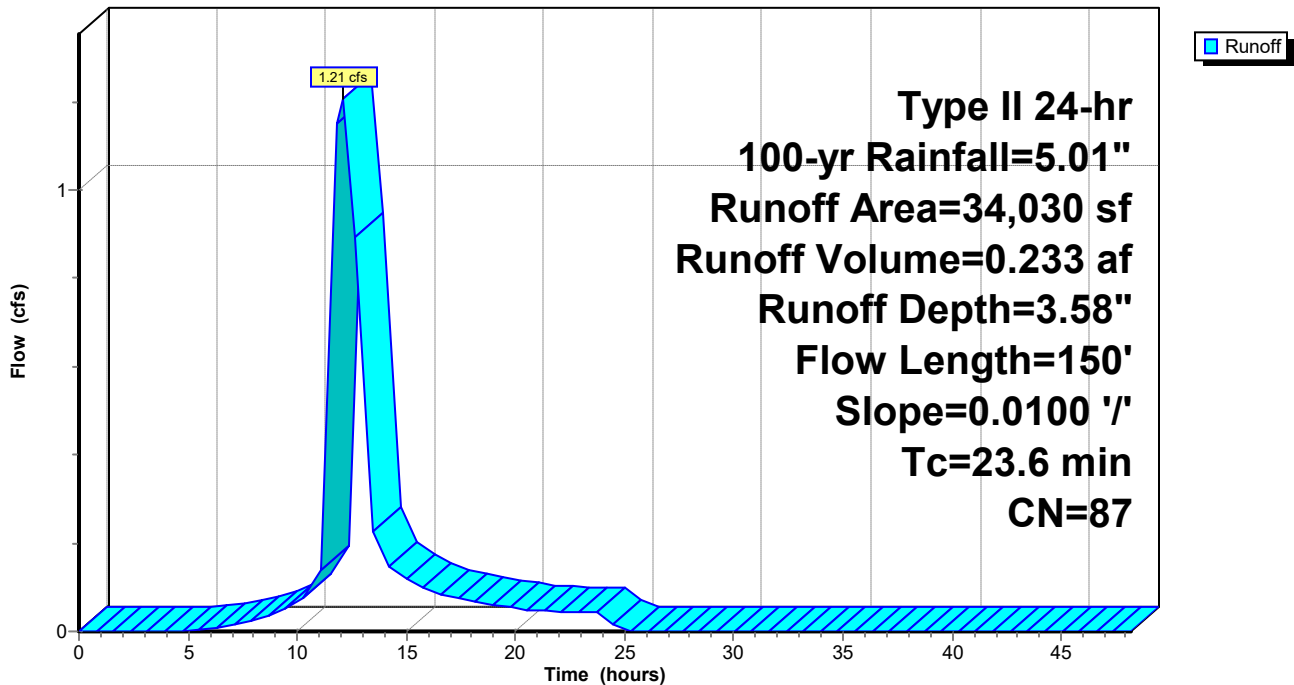

Plug Power - Proposed Conditions 5-15-21

Type II 24-hr 100-yr Rainfall=5.01"

Prepared by {enter your company name here}

Printed 5/20/2021

HydroCAD® 10.10-5a s/n 11585 © 2020 HydroCAD Software Solutions LLC

Page 35

Summary for Subcatchment 49S: Area to YD#3

Runoff = 2.63 cfs @ 12.17 hrs, Volume= 0.529 af, Depth= 3.38"

Runoff by SCS TR-20 method, UH=SCS, Weighted-CN, Time Span= 0.00-48.19 hrs, dt= 0.79 hrs
Type II 24-hr 100-yr Rainfall=5.01"

Area (sf)	CN	Description
20,040	98	Paved parking, HSG D
57,195	80	>75% Grass cover, Good, HSG D
4,600	98	Roofs, HSG D
81,835	85	Weighted Average
57,195		69.89% Pervious Area
24,640		30.11% Impervious Area

Tc (min)	Length (feet)	Slope (ft/ft)	Velocity (ft/sec)	Capacity (cfs)	Description
23.0	100	0.0100	0.07		Sheet Flow, 100' Overland Flow Grass: Dense n= 0.240 P2= 2.14"
0.3	60	0.0200	2.87		Shallow Concentrated Flow, 60' Shallow Conc. Flow Paved Kv= 20.3 fps
2.0	180	0.0100	1.50		Shallow Concentrated Flow, 180' Shallow Conc. Flow Grassed Waterway Kv= 15.0 fps
25.3	340	Total			

Subcatchment 49S: Area to YD#3

Hydrograph

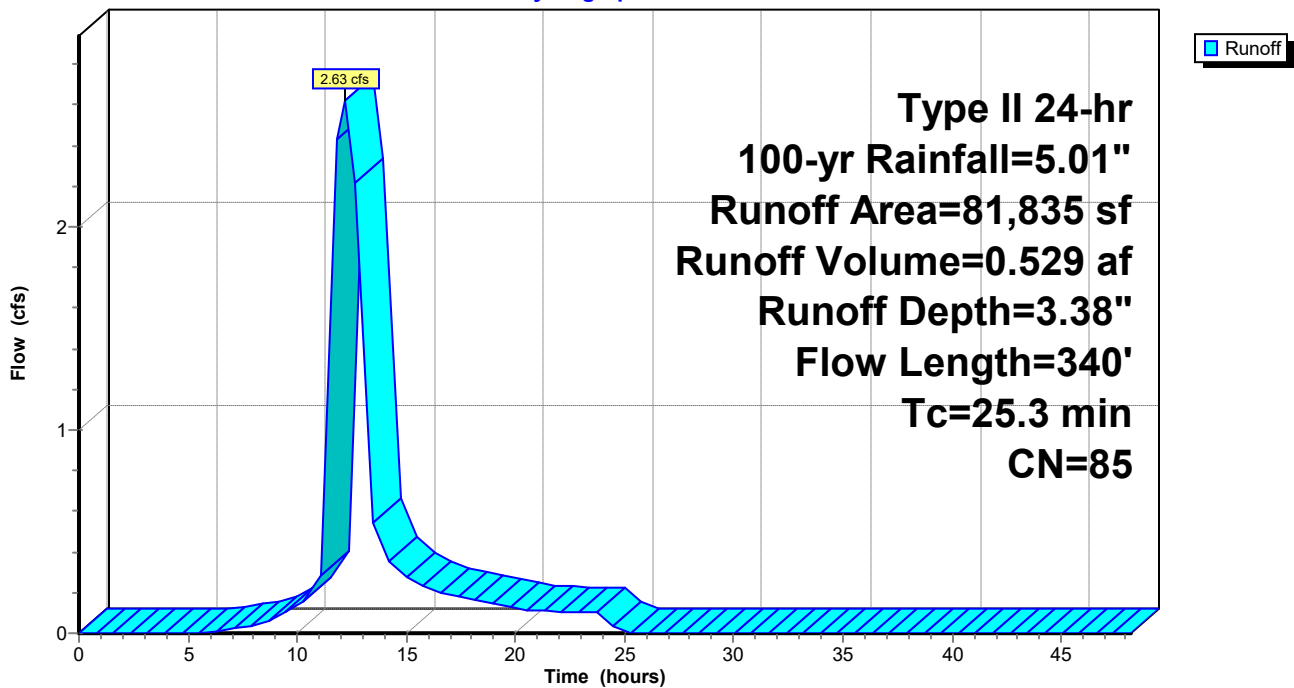

Plug Power - Proposed Conditions 5-15-21

Type II 24-hr 100-yr Rainfall=5.01"

Prepared by {enter your company name here}

Printed 5/20/2021

HydroCAD® 10.10-5a s/n 11585 © 2020 HydroCAD Software Solutions LLC

Page 36

Summary for Subcatchment 52S: Area Overland to Bio-Retention Area

Runoff = 2.93 cfs @ 11.88 hrs, Volume= 0.396 af, Depth= 2.90"

Runoff by SCS TR-20 method, UH=SCS, Weighted-CN, Time Span= 0.00-48.19 hrs, dt= 0.79 hrs
 Type II 24-hr 100-yr Rainfall=5.01"

Area (sf)	CN	Description
71,325	80	>75% Grass cover, Good, HSG D
71,325		100.00% Pervious Area

Tc (min)	Length (feet)	Slope (ft/ft)	Velocity (ft/sec)	Capacity (cfs)	Description
3.6	10	0.0100	0.05		Sheet Flow, 10' Overland Flow Grass: Dense n= 0.240 P2= 2.14"
1.8	20	0.2500	0.19		Sheet Flow, 20' Overland Flow Grass: Dense n= 0.240 P2= 2.14"
5.4	30	Total			

Subcatchment 52S: Area Overland to Bio-Retention Area

Hydrograph

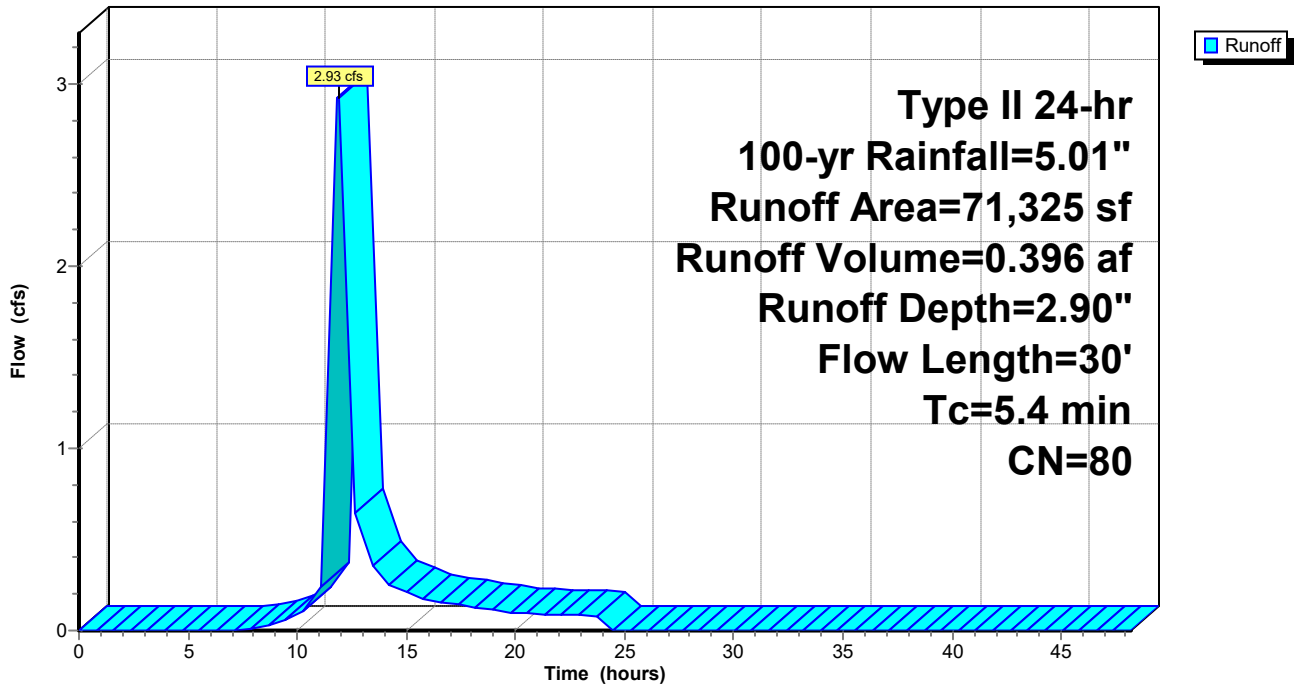

Plug Power - Proposed Conditions 5-15-21

Type II 24-hr 100-yr Rainfall=5.01"

Prepared by {enter your company name here}

Printed 5/20/2021

HydroCAD® 10.10-5a s/n 11585 © 2020 HydroCAD Software Solutions LLC

Page 37

Summary for Subcatchment 53S: Area Overland to Western Swale to Bio-Retention Area

Runoff = 0.24 cfs @ 11.88 hrs, Volume= 0.033 af, Depth= 2.90"

Runoff by SCS TR-20 method, UH=SCS, Weighted-CN, Time Span= 0.00-48.19 hrs, dt= 0.79 hrs
 Type II 24-hr 100-yr Rainfall=5.01"

Area (sf)	CN	Description
5,925	80	>75% Grass cover, Good, HSG D
5,925		100.00% Pervious Area

Tc (min)	Length (feet)	Slope (ft/ft)	Velocity (ft/sec)	Capacity (cfs)	Description
5.0					Direct Entry,

Subcatchment 53S: Area Overland to Western Swale to Bio-Retention Area

Hydrograph

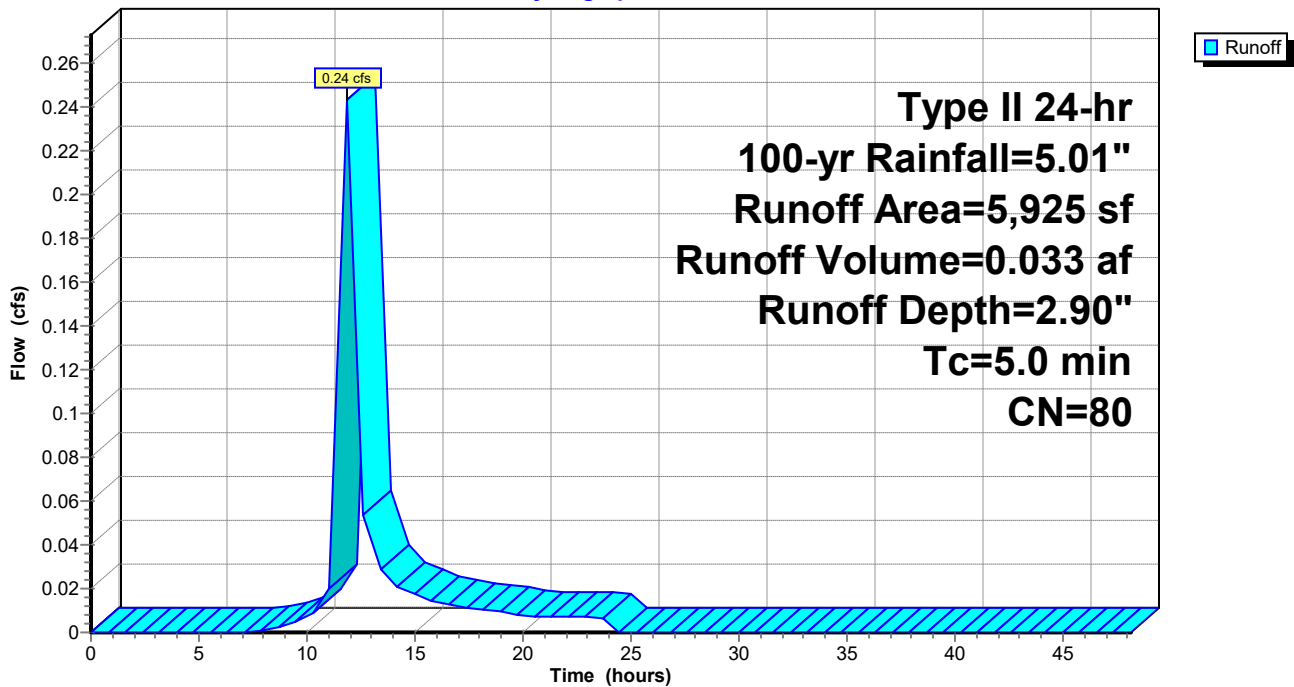

Plug Power - Proposed Conditions 5-15-21

Type II 24-hr 100-yr Rainfall=5.01"

Prepared by {enter your company name here}

Printed 5/20/2021

HydroCAD® 10.10-5a s/n 11585 © 2020 HydroCAD Software Solutions LLC

Page 38

Summary for Subcatchment 54S: Area Overland to Northern Swale to Bio-Retention Area

Runoff = 0.25 cfs @ 11.88 hrs, Volume= 0.034 af, Depth= 2.90"

Runoff by SCS TR-20 method, UH=SCS, Weighted-CN, Time Span= 0.00-48.19 hrs, dt= 0.79 hrs
 Type II 24-hr 100-yr Rainfall=5.01"

Area (sf)	CN	Description
6,040	80	>75% Grass cover, Good, HSG D
6,040		100.00% Pervious Area

Tc (min)	Length (feet)	Slope (ft/ft)	Velocity (ft/sec)	Capacity (cfs)	Description
5.0					Direct Entry,

Subcatchment 54S: Area Overland to Northern Swale to Bio-Retention Area

Hydrograph

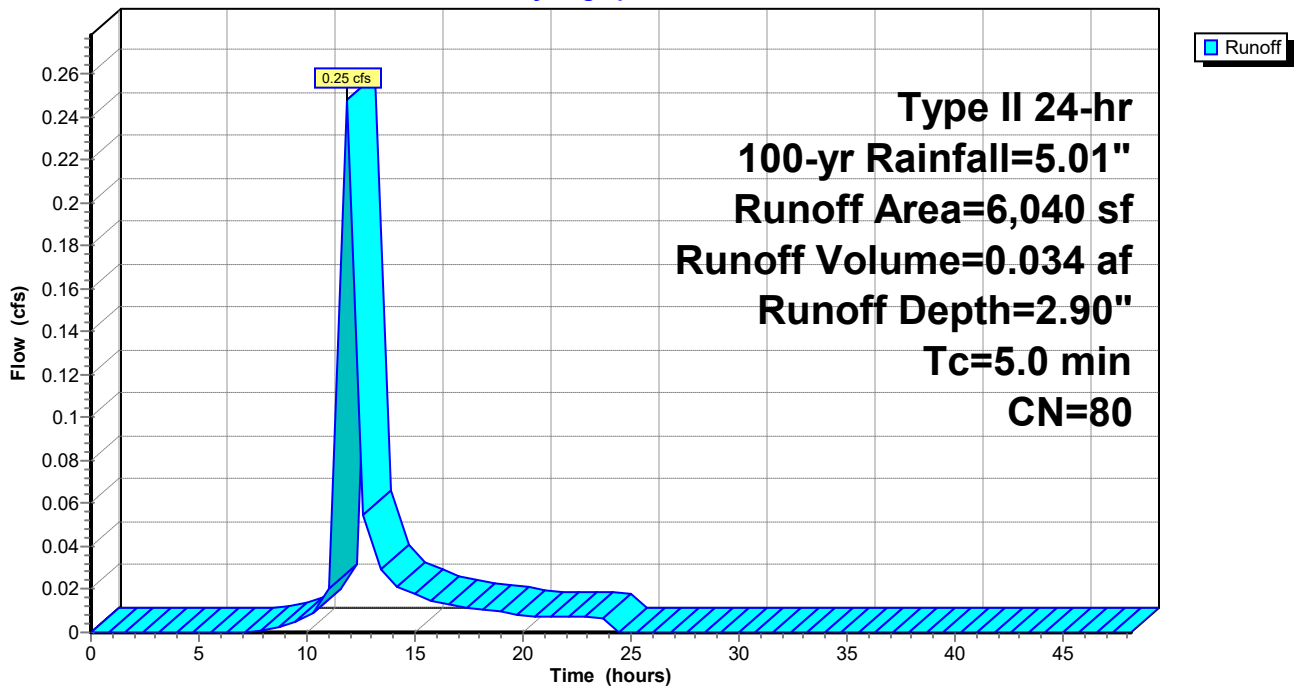

Plug Power - Proposed Conditions 5-15-21

Type II 24-hr 100-yr Rainfall=5.01"

Prepared by {enter your company name here}

Printed 5/20/2021

HydroCAD® 10.10-5a s/n 11585 © 2020 HydroCAD Software Solutions LLC

Page 39

Summary for Subcatchment 55S: Area Overland to Swales to Dry Pond

Runoff = 0.53 cfs @ 11.89 hrs, Volume= 0.073 af, Depth= 2.90"

Runoff by SCS TR-20 method, UH=SCS, Weighted-CN, Time Span= 0.00-48.19 hrs, dt= 0.79 hrs
Type II 24-hr 100-yr Rainfall=5.01"

Area (sf)	CN	Description
13,210	80	>75% Grass cover, Good, HSG D
13,210		100.00% Pervious Area

Tc (min)	Length (feet)	Slope (ft/ft)	Velocity (ft/sec)	Capacity (cfs)	Description
7.6	25	0.0100	0.05		Sheet Flow, 25' Overland Flow Grass: Dense n= 0.240 P2= 2.14"

Subcatchment 55S: Area Overland to Swales to Dry Pond

Hydrograph

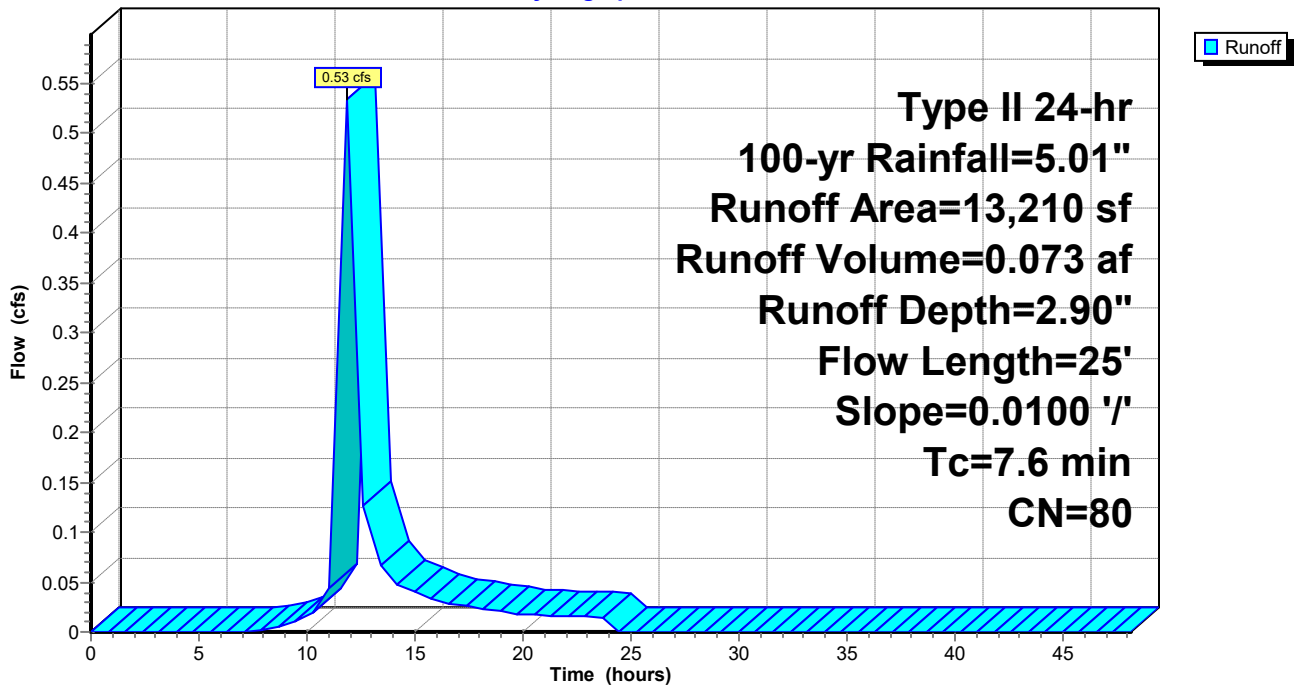

Plug Power - Proposed Conditions 5-15-21

Type II 24-hr 100-yr Rainfall=5.01"

Prepared by {enter your company name here}

Printed 5/20/2021

HydroCAD® 10.10-5a s/n 11585 © 2020 HydroCAD Software Solutions LLC

Page 40

Summary for Subcatchment 56S: Area Overland to Dry Pond

Runoff = 0.79 cfs @ 11.88 hrs, Volume= 0.107 af, Depth= 2.90"

Runoff by SCS TR-20 method, UH=SCS, Weighted-CN, Time Span= 0.00-48.19 hrs, dt= 0.79 hrs
 Type II 24-hr 100-yr Rainfall=5.01"

Area (sf)	CN	Description
19,245	80	>75% Grass cover, Good, HSG D
19,245		100.00% Pervious Area

Tc (min)	Length (feet)	Slope (ft/ft)	Velocity (ft/sec)	Capacity (cfs)	Description
5.0					Direct Entry,

Subcatchment 56S: Area Overland to Dry Pond

Hydrograph

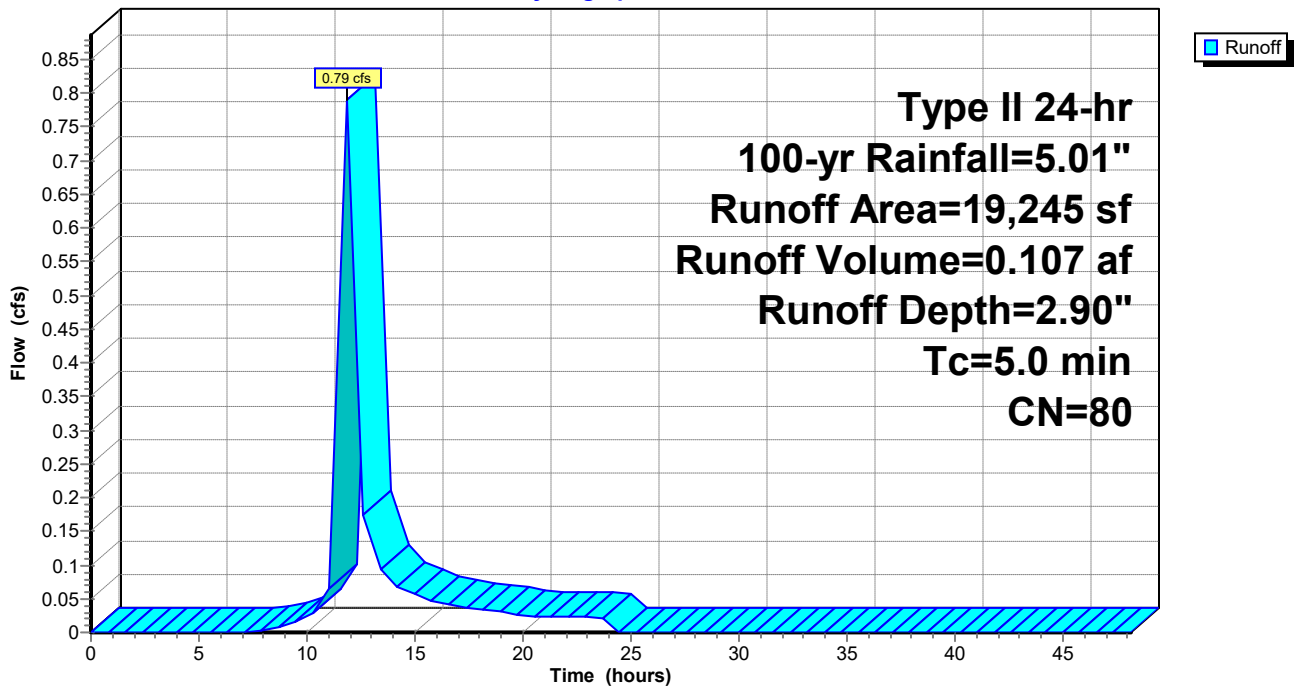

Plug Power - Proposed Conditions 5-15-21

Type II 24-hr 100-yr Rainfall=5.01"

Prepared by {enter your company name here}

Printed 5/20/2021

HydroCAD® 10.10-5a s/n 11585 © 2020 HydroCAD Software Solutions LLC

Page 41

Summary for Subcatchment 57S: Area Overland to North Prop. Line and Wetland Ditch (Central)

Runoff = 0.83 cfs @ 11.90 hrs, Volume= 0.119 af, Depth= 2.63"

Runoff by SCS TR-20 method, UH=SCS, Weighted-CN, Time Span= 0.00-48.19 hrs, dt= 0.79 hrs
 Type II 24-hr 100-yr Rainfall=5.01"

Area (sf)	CN	Description
23,585	77	Brush, Fair, HSG D
23,585		100.00% Pervious Area

Tc (min)	Length (feet)	Slope (ft/ft)	Velocity (ft/sec)	Capacity (cfs)	Description
10.6	70	0.0100	0.11		Sheet Flow, 70' Overland Flow Range n= 0.130 P2= 2.14"
0.2	30	0.1000	2.21		Shallow Concentrated Flow, 30' Shallow Conc. Flow Short Grass Pasture Kv= 7.0 fps
10.8	100	Total			

Subcatchment 57S: Area Overland to North Prop. Line and Wetland Ditch (Central)

Hydrograph

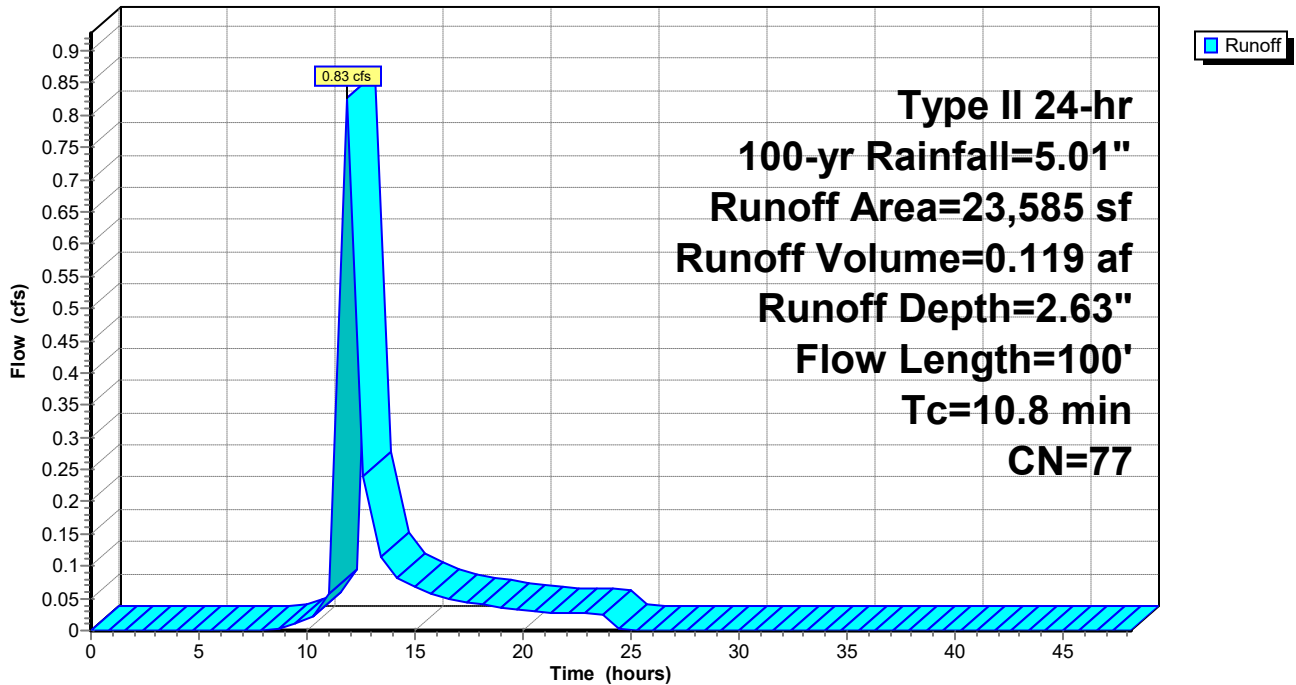

Plug Power - Proposed Conditions 5-15-21

Type II 24-hr 100-yr Rainfall=5.01"

Prepared by {enter your company name here}

Printed 5/20/2021

HydroCAD® 10.10-5a s/n 11585 © 2020 HydroCAD Software Solutions LLC

Page 42

Summary for Subcatchment 58S: Area Overland to North Prop. Line and Wetland Ditch (West)

Runoff = 0.55 cfs @ 11.93 hrs, Volume= 0.086 af, Depth= 2.63"

Runoff by SCS TR-20 method, UH=SCS, Weighted-CN, Time Span= 0.00-48.19 hrs, dt= 0.79 hrs
 Type II 24-hr 100-yr Rainfall=5.01"

Area (sf)	CN	Description
17,005	77	Brush, Fair, HSG D
17,005		100.00% Pervious Area

Tc (min)	Length (feet)	Slope (ft/ft)	Velocity (ft/sec)	Capacity (cfs)	Description
14.1	100	0.0100	0.12		Sheet Flow, 100' Overland Flow Range n= 0.130 P2= 2.14"
0.8	70	0.0400	1.40		Shallow Concentrated Flow, 70' Shallow Conc. Flow Short Grass Pasture Kv= 7.0 fps
14.9	170	Total			

Subcatchment 58S: Area Overland to North Prop. Line and Wetland Ditch (West)

Hydrograph

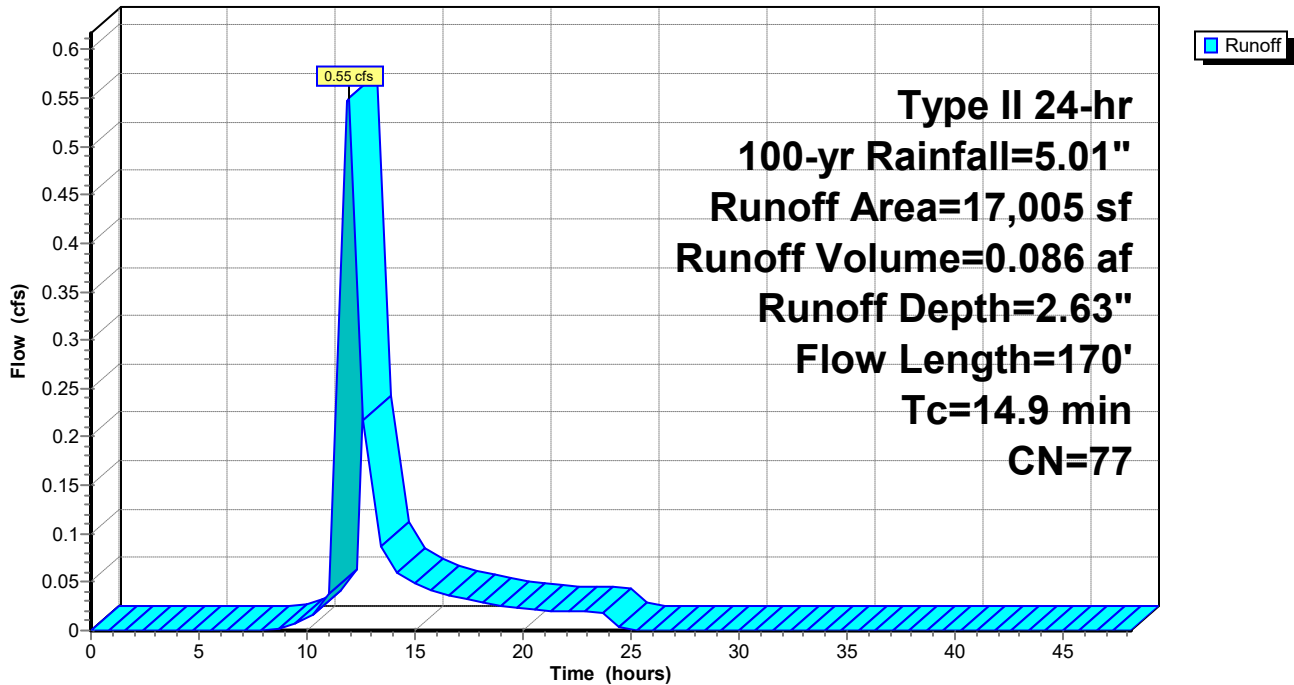

Plug Power - Proposed Conditions 5-15-21

Type II 24-hr 100-yr Rainfall=5.01"

Prepared by {enter your company name here}

Printed 5/20/2021

HydroCAD® 10.10-5a s/n 11585 © 2020 HydroCAD Software Solutions LLC

Page 43

Summary for Reach 7R: Crosby Road Ditch

Inflow Area = 0.230 ac, 0.00% Impervious, Inflow Depth = 2.81" for 100-yr event
Inflow = 0.28 cfs @ 12.12 hrs, Volume= 0.054 af
Outflow = 0.27 cfs @ 12.41 hrs, Volume= 0.054 af, Atten= 3%, Lag= 17.4 min

Routing by Dyn-Stor-Ind method, Time Span= 0.00-48.19 hrs, dt= 0.79 hrs / 2
Max. Velocity= 0.96 fps, Min. Travel Time= 7.8 min
Avg. Velocity = 0.43 fps, Avg. Travel Time= 17.5 min

Peak Storage= 125 cf @ 12.40 hrs
Average Depth at Peak Storage= 0.11' , Surface Width= 2.91'
Bank-Full Depth= 2.00' Flow Area= 20.0 sf, Capacity= 98.41 cfs

2.00' x 2.00' deep channel, n= 0.030
Side Slope Z-value= 4.0 ' / ' Top Width= 18.00'
Length= 450.0' Slope= 0.0089 ' / '
Inlet Invert= 673.00', Outlet Invert= 669.00'

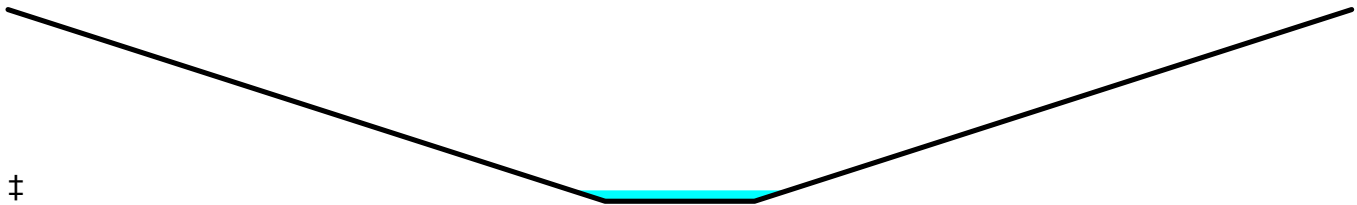

Reach 7R: Crosby Road Ditch

Hydrograph

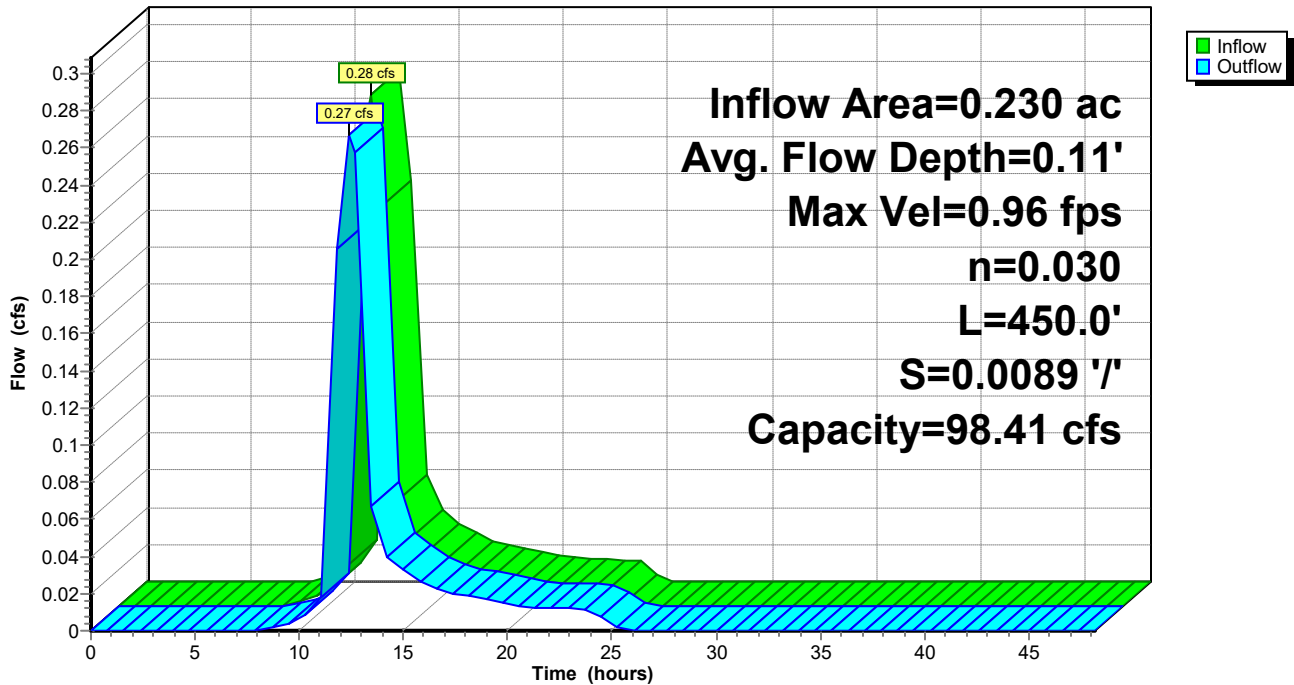

Plug Power - Proposed Conditions 5-15-21

Type II 24-hr 100-yr Rainfall=5.01"

Prepared by {enter your company name here}

Printed 5/20/2021

HydroCAD® 10.10-5a s/n 11585 © 2020 HydroCAD Software Solutions LLC

Page 44

Summary for Reach 9R: North Property Line Ditch (East)

Inflow Area = 1.403 ac, 0.00% Impervious, Inflow Depth = 2.66" for 100-yr event
Inflow = 1.98 cfs @ 11.94 hrs, Volume= 0.311 af
Outflow = 1.66 cfs @ 12.12 hrs, Volume= 0.311 af, Atten= 16%, Lag= 10.7 min

Routing by Dyn-Stor-Ind method, Time Span= 0.00-48.19 hrs, dt= 0.79 hrs / 2
Max. Velocity= 1.44 fps, Min. Travel Time= 7.7 min
Avg. Velocity = 0.68 fps, Avg. Travel Time= 16.4 min

Peak Storage= 771 cf @ 12.14 hrs
Average Depth at Peak Storage= 0.26' , Surface Width= 7.18'
Bank-Full Depth= 3.00' Flow Area= 96.0 sf, Capacity= 634.40 cfs

2.00' x 3.00' deep channel, n= 0.030 Earth, grassed & winding
Side Slope Z-value= 10.0 ' / ' Top Width= 62.00'
Length= 670.0' Slope= 0.0100 ' / '
Inlet Invert= 669.00', Outlet Invert= 662.30'

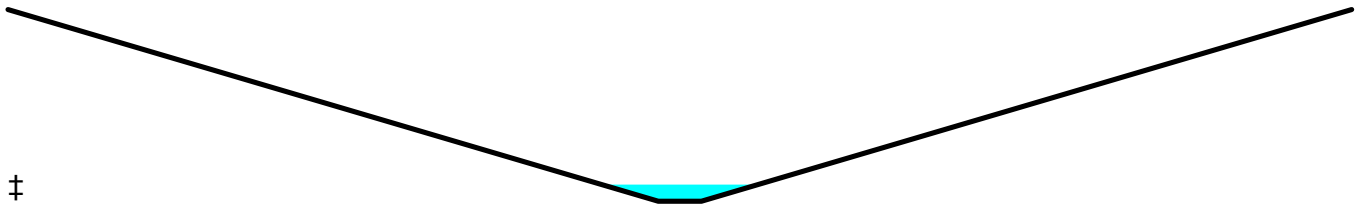

Reach 9R: North Property Line Ditch (East)

Hydrograph

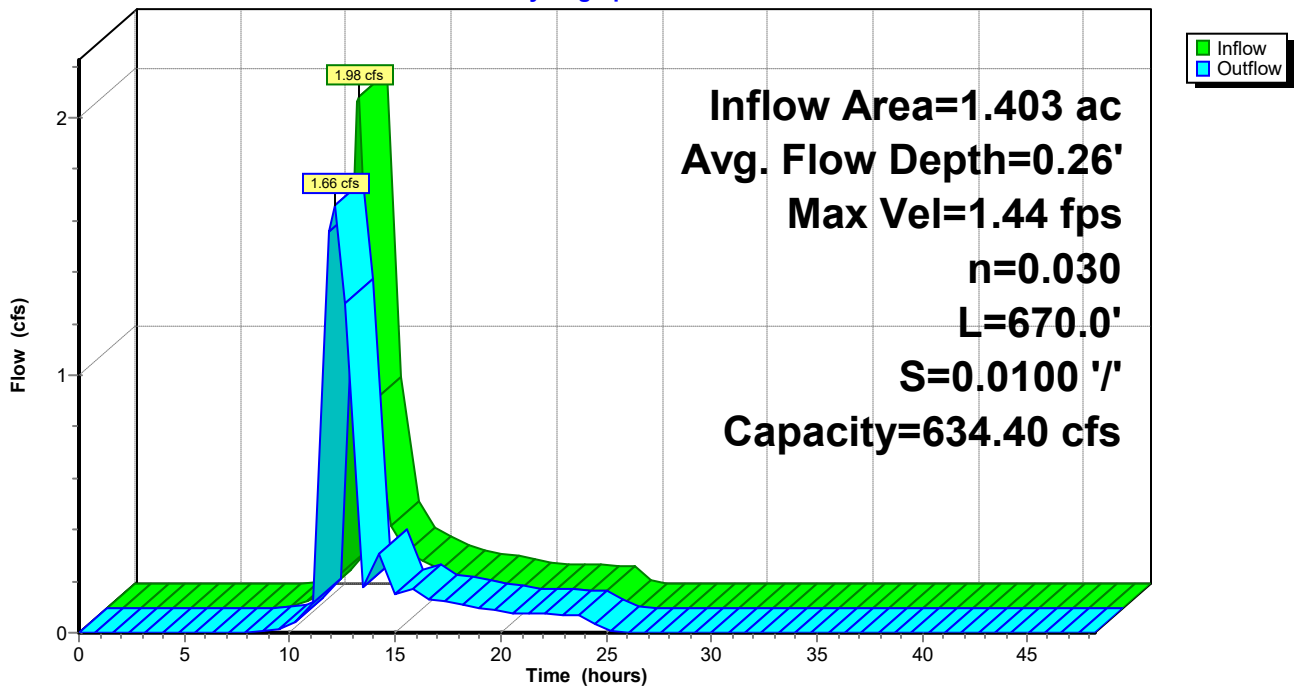

Plug Power - Proposed Conditions 5-15-21

Type II 24-hr 100-yr Rainfall=5.01"

Prepared by {enter your company name here}

Printed 5/20/2021

HydroCAD® 10.10-5a s/n 11585 © 2020 HydroCAD Software Solutions LLC

Page 45

Summary for Reach 23R: North Swale to Bio-Retention Area

Inflow Area = 0.139 ac, 0.00% Impervious, Inflow Depth =264.44" for 100-yr event
Inflow = 10.14 cfs @ 12.15 hrs, Volume= 3.056 af
Outflow = 9.97 cfs @ 12.38 hrs, Volume= 3.056 af, Atten= 2%, Lag= 14.2 min

Routing by Dyn-Stor-Ind method, Time Span= 0.00-48.19 hrs, dt= 0.79 hrs / 2
Max. Velocity= 0.39 fps, Min. Travel Time= 7.6 min
Avg. Velocity = 0.14 fps, Avg. Travel Time= 22.1 min

Peak Storage= 4,552 cf @ 12.37 hrs
Average Depth at Peak Storage= 2.07' , Surface Width= 20.58'
Bank-Full Depth= 3.00' Flow Area= 48.0 sf, Capacity= 23.67 cfs

4.00' x 3.00' deep channel, n= 0.300
Side Slope Z-value= 4.0 ' / ' Top Width= 28.00'
Length= 180.0' Slope= 0.0050 ' / '
Inlet Invert= 663.90', Outlet Invert= 663.00'



Reach 23R: North Swale to Bio-Retention Area

Hydrograph

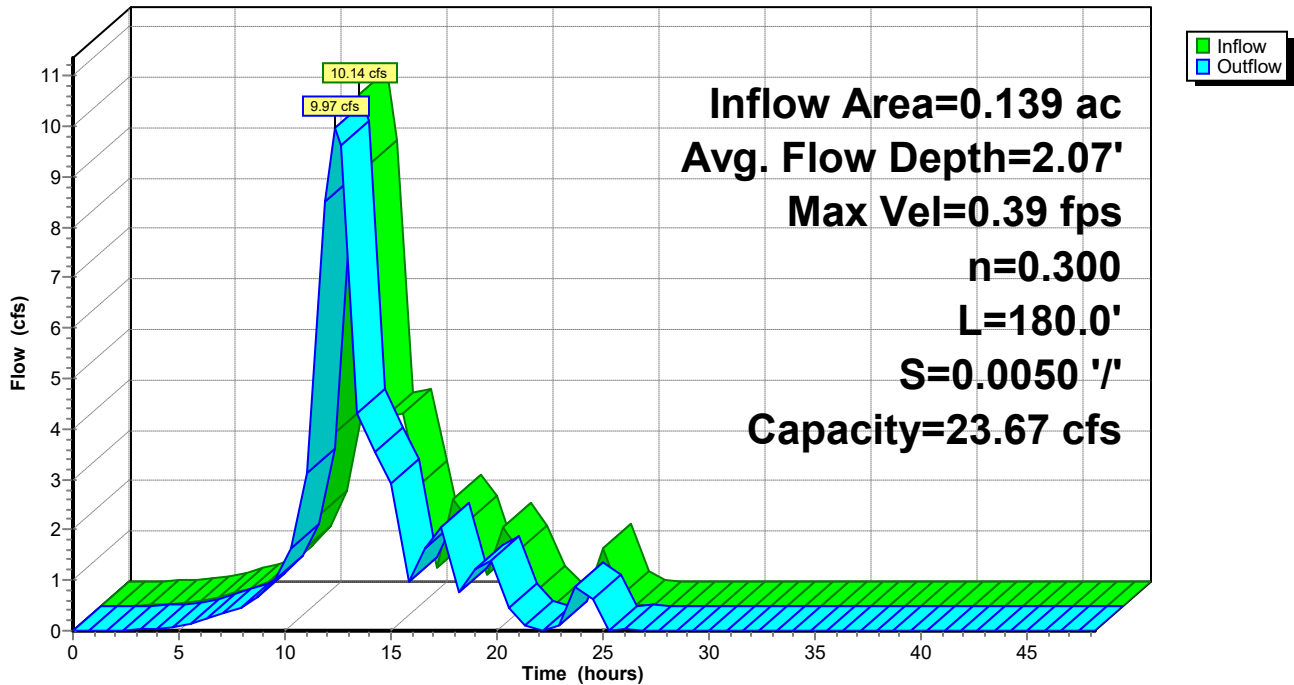

Plug Power - Proposed Conditions 5-15-21

Prepared by {enter your company name here}

HydroCAD® 10.10-5a s/n 11585 © 2020 HydroCAD Software Solutions LLC

Type II 24-hr 100-yr Rainfall=5.01"

Printed 5/20/2021

Page 46

Summary for Reach 25R: North Property Line Ditch (Central0)

Inflow Area = 2.689 ac, 0.00% Impervious, Inflow Depth = 8.28" for 100-yr event
Inflow = 11.69 cfs @ 12.60 hrs, Volume= 1.856 af
Outflow = 11.30 cfs @ 12.66 hrs, Volume= 1.856 af, Atten= 3%, Lag= 3.8 min

Routing by Dyn-Stor-Ind method, Time Span= 0.00-48.19 hrs, dt= 0.79 hrs / 2
Max. Velocity= 1.71 fps, Min. Travel Time= 4.9 min
Avg. Velocity = 0.55 fps, Avg. Travel Time= 15.2 min

Peak Storage= 3,312 cf @ 12.67 hrs
Average Depth at Peak Storage= 0.72' , Surface Width= 16.40'
Bank-Full Depth= 3.00' Flow Area= 96.0 sf, Capacity= 401.23 cfs

2.00' x 3.00' deep channel, n= 0.030 Earth, grassed & winding
Side Slope Z-value= 10.0 ' / ' Top Width= 62.00'
Length= 500.0' Slope= 0.0040 ' / '
Inlet Invert= 662.30', Outlet Invert= 660.30'

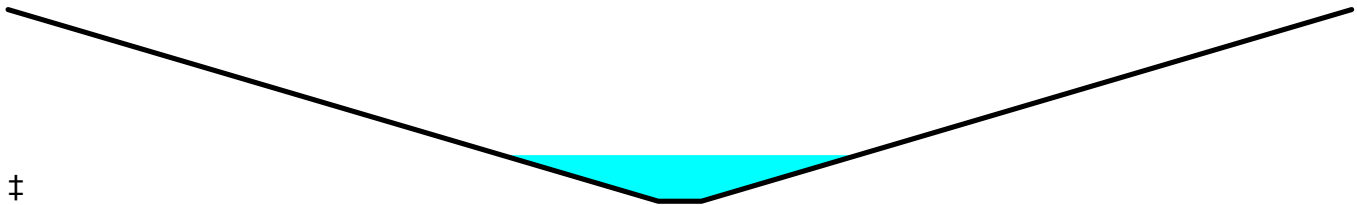

Reach 25R: North Property Line Ditch (Central0)

Hydrograph

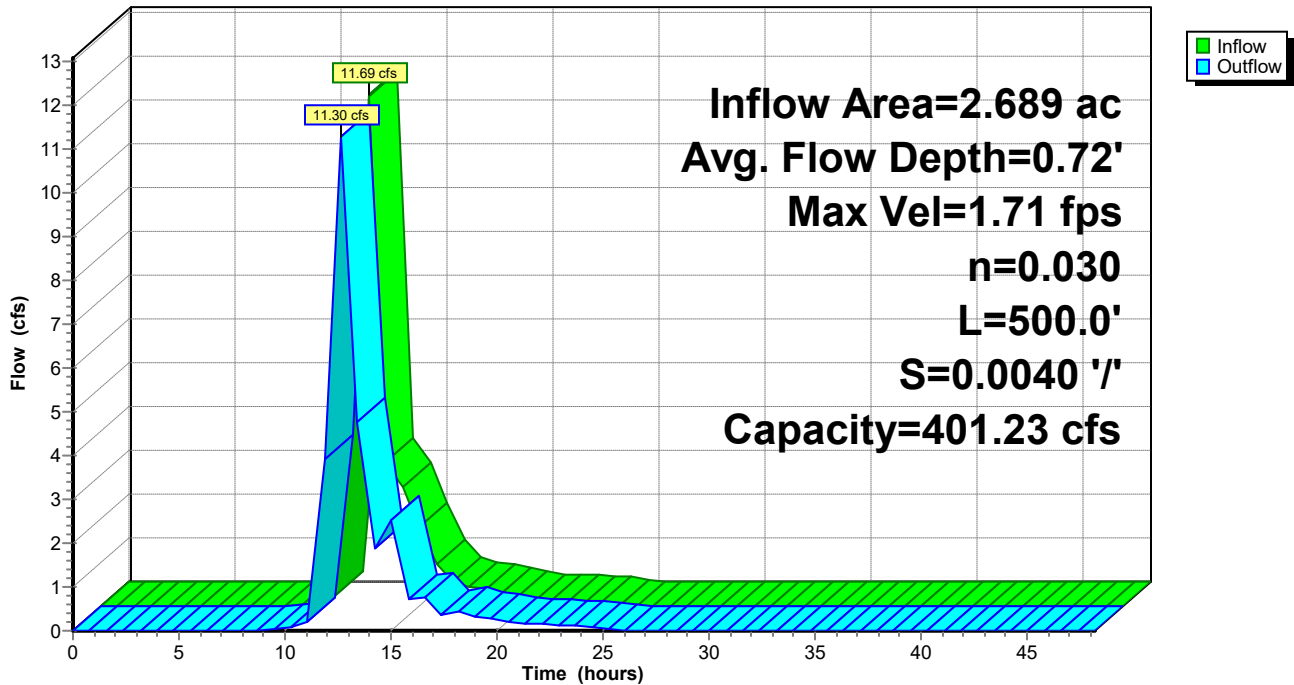

Plug Power - Proposed Conditions 5-15-21

Type II 24-hr 100-yr Rainfall=5.01"

Prepared by {enter your company name here}

Printed 5/20/2021

HydroCAD® 10.10-5a s/n 11585 © 2020 HydroCAD Software Solutions LLC

Page 47

Summary for Reach 26R: North Property Line Ditch (West)

Inflow Area = 27.347 ac, 45.74% Impervious, Inflow Depth = 4.20" for 100-yr event
Inflow = 35.65 cfs @ 12.77 hrs, Volume= 9.566 af
Outflow = 33.08 cfs @ 12.88 hrs, Volume= 9.568 af, Atten= 7%, Lag= 6.4 min

Routing by Dyn-Stor-Ind method, Time Span= 0.00-48.19 hrs, dt= 0.79 hrs / 2
Max. Velocity= 1.83 fps, Min. Travel Time= 4.6 min
Avg. Velocity = 0.79 fps, Avg. Travel Time= 10.6 min

Peak Storage= 9,058 cf @ 12.90 hrs
Average Depth at Peak Storage= 1.27' , Surface Width= 27.35'
Bank-Full Depth= 3.00' Flow Area= 96.0 sf, Capacity= 310.79 cfs

2.00' x 3.00' deep channel, n= 0.030 Earth, grassed & winding
Side Slope Z-value= 10.0 ' / ' Top Width= 62.00'
Length= 500.0' Slope= 0.0024 ' / '
Inlet Invert= 660.30', Outlet Invert= 659.10'

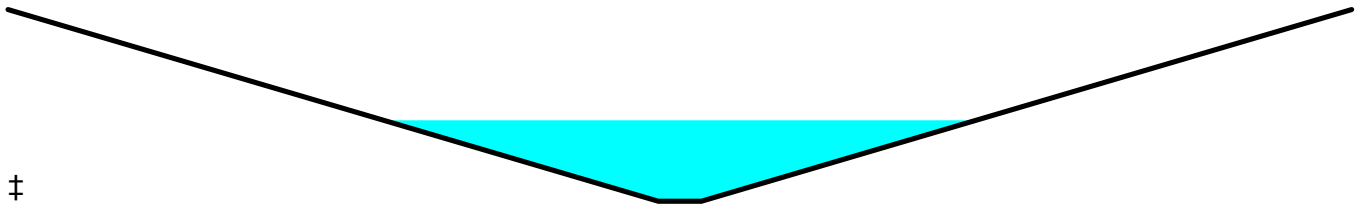

Reach 26R: North Property Line Ditch (West)

Hydrograph

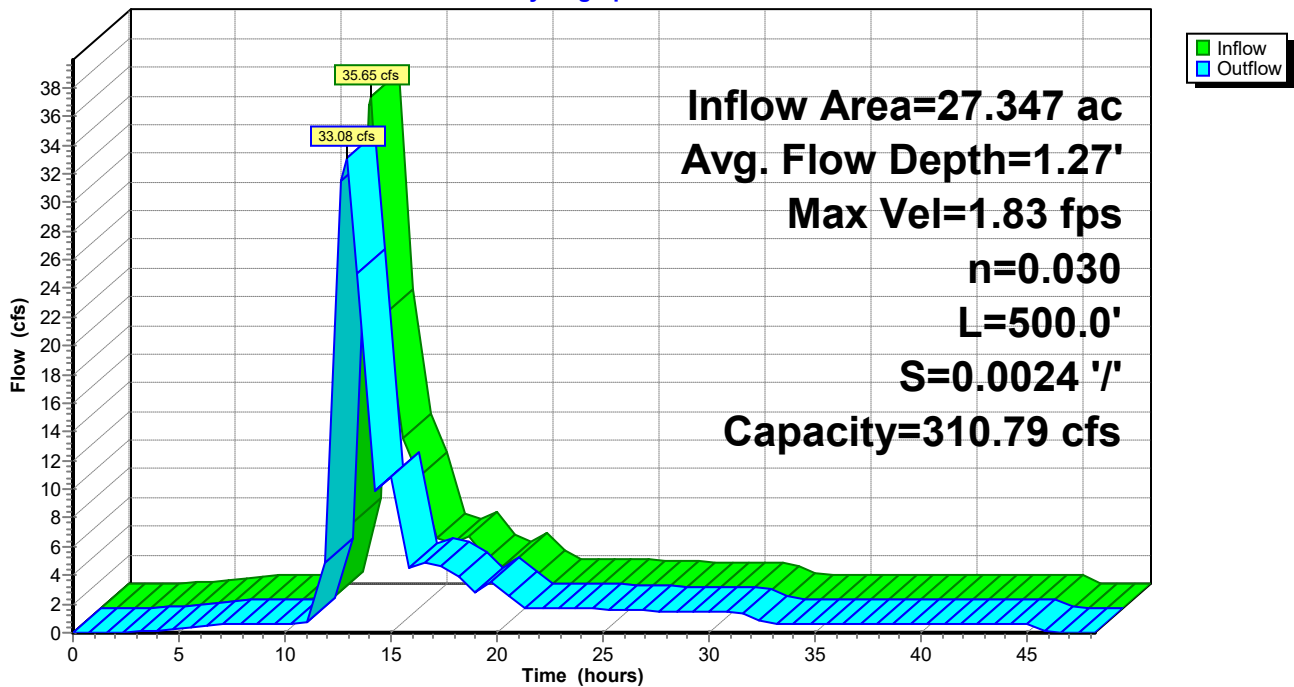

Plug Power - Proposed Conditions 5-15-21

Type II 24-hr 100-yr Rainfall=5.01"

Prepared by {enter your company name here}

Printed 5/20/2021

HydroCAD® 10.10-5a s/n 11585 © 2020 HydroCAD Software Solutions LLC

Page 48

Summary for Reach 27R: Swale to Dry Pond

Inflow Area = 0.303 ac, 0.00% Impervious, Inflow Depth = 52.19" for 100-yr event
Inflow = 11.83 cfs @ 12.10 hrs, Volume= 1.319 af
Outflow = 11.53 cfs @ 12.14 hrs, Volume= 1.320 af, Atten= 3%, Lag= 2.8 min

Routing by Dyn-Stor-Ind method, Time Span= 0.00-48.19 hrs, dt= 0.79 hrs / 2
Max. Velocity= 2.00 fps, Min. Travel Time= 1.1 min
Avg. Velocity = 0.43 fps, Avg. Travel Time= 5.0 min

Peak Storage= 756 cf @ 12.16 hrs
Average Depth at Peak Storage= 0.73' , Surface Width= 12.78'
Bank-Full Depth= 2.00' Flow Area= 32.0 sf, Capacity= 118.87 cfs

A factor of 2.00 has been applied to the storage and discharge capacity
2.00' x 2.00' deep channel, n= 0.030
Side Slope Z-value= 3.0 '/' Top Width= 14.00'
Length= 130.0' Slope= 0.0050 '/'
Inlet Invert= 665.85', Outlet Invert= 665.20'



Reach 27R: Swale to Dry Pond

Hydrograph

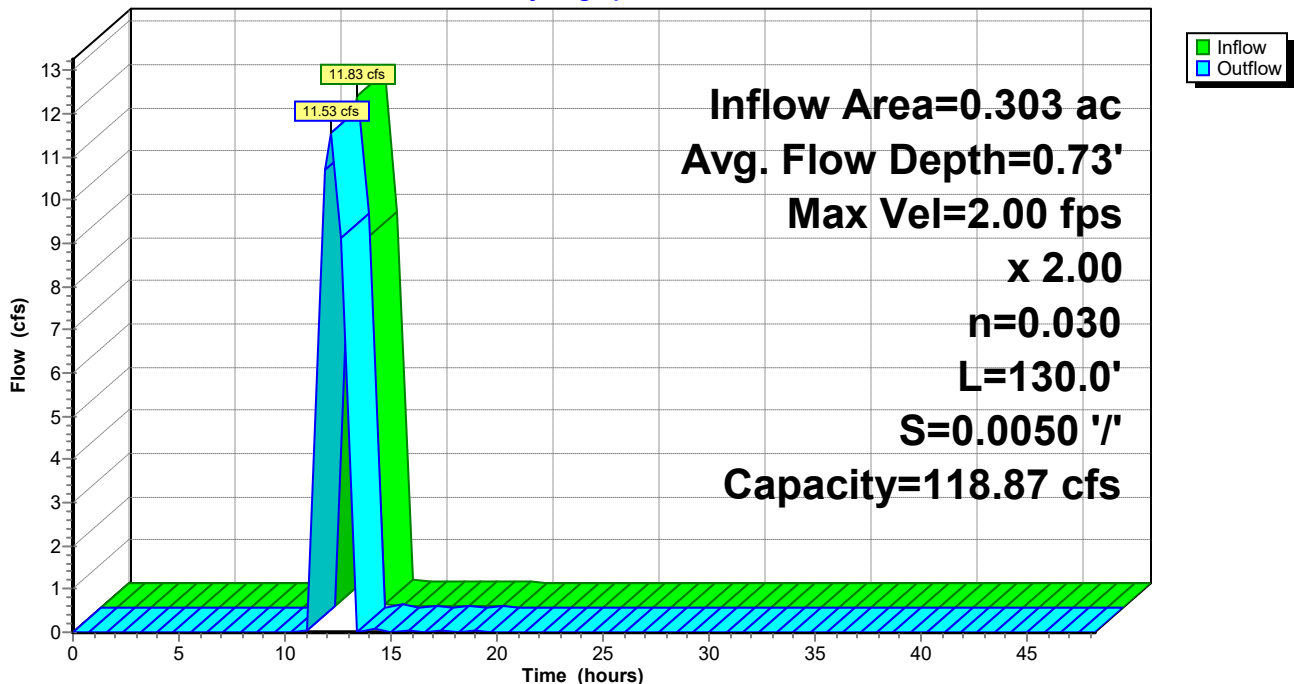

Plug Power - Proposed Conditions 5-15-21

Type II 24-hr 100-yr Rainfall=5.01"

Prepared by {enter your company name here}

Printed 5/20/2021

HydroCAD® 10.10-5a s/n 11585 © 2020 HydroCAD Software Solutions LLC

Page 49

Summary for Reach 52R: West Swale to Bio-Retention Area

Inflow Area = 22.492 ac, 55.62% Impervious, Inflow Depth = 2.22" for 100-yr event
 Inflow = 14.63 cfs @ 12.16 hrs, Volume= 4.160 af
 Outflow = 14.26 cfs @ 12.47 hrs, Volume= 4.160 af, Atten= 3%, Lag= 18.6 min

Routing by Dyn-Stor-Ind method, Time Span= 0.00-48.19 hrs, dt= 0.79 hrs / 2
 Max. Velocity= 0.43 fps, Min. Travel Time= 7.0 min
 Avg. Velocity = 0.15 fps, Avg. Travel Time= 19.4 min

Peak Storage= 5,935 cf @ 12.46 hrs
 Average Depth at Peak Storage= 2.42' , Surface Width= 23.37'
 Bank-Full Depth= 3.00' Flow Area= 48.0 sf, Capacity= 23.67 cfs

4.00' x 3.00' deep channel, n= 0.300
 Side Slope Z-value= 4.0 '/' Top Width= 28.00'
 Length= 180.0' Slope= 0.0050 '/'
 Inlet Invert= 663.90', Outlet Invert= 663.00'



Reach 52R: West Swale to Bio-Retention Area

Hydrograph

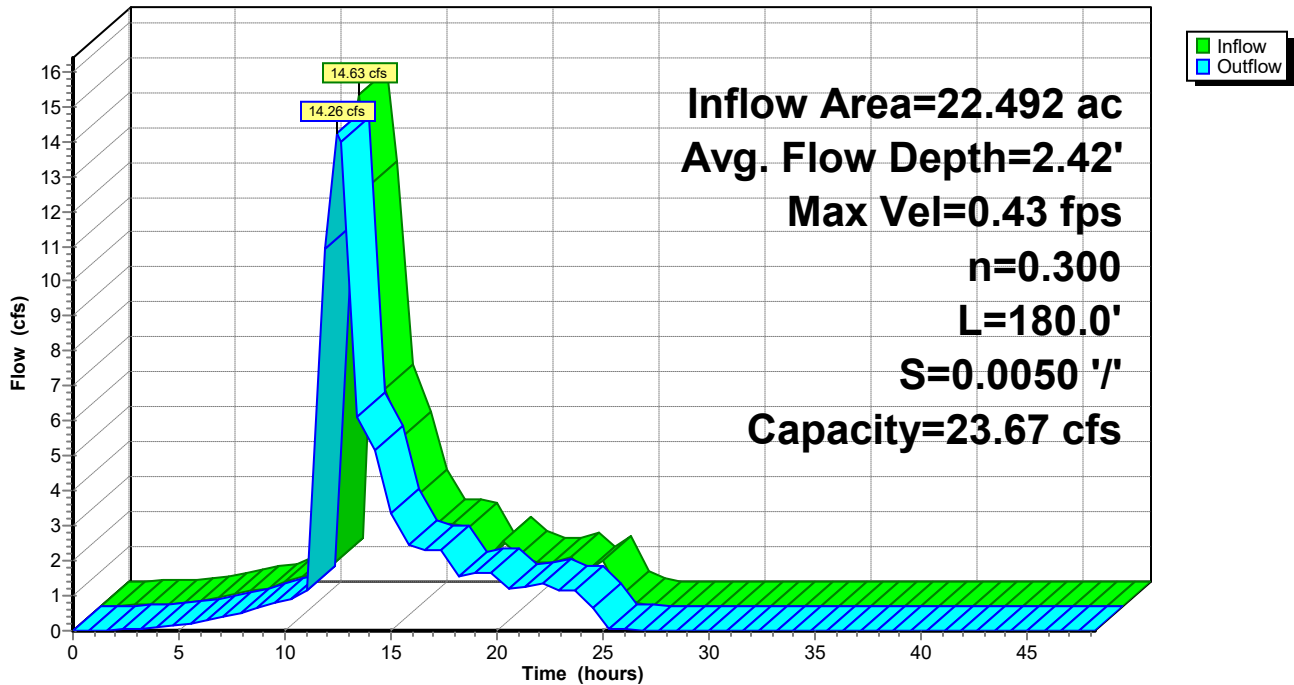

Plug Power - Proposed Conditions 5-15-21

Type II 24-hr 100-yr Rainfall=5.01"

Prepared by {enter your company name here}

Printed 5/20/2021

HydroCAD® 10.10-5a s/n 11585 © 2020 HydroCAD Software Solutions LLC

Page 50

Summary for Pond 11P: CB#1

Inflow Area = 0.442 ac, 67.06% Impervious, Inflow Depth = 4.10" for 100-yr event
Inflow = 1.02 cfs @ 11.89 hrs, Volume= 0.151 af
Outflow = 1.02 cfs @ 11.89 hrs, Volume= 0.151 af, Atten= 0%, Lag= 0.0 min
Primary = 1.02 cfs @ 11.89 hrs, Volume= 0.151 af

Routing by Dyn-Stor-Ind method, Time Span= 0.00-48.19 hrs, dt= 0.79 hrs / 2

Peak Elev= 668.36' @ 12.09 hrs

Flood Elev= 672.65'

Device	Routing	Invert	Outlet Devices
#1	Primary	667.41'	12.0" Round Culvert L= 137.0' CPP, square edge headwall, Ke= 0.500 Inlet / Outlet Invert= 667.41' / 667.14' S= 0.0020 '/ Cc= 0.900 n= 0.012, Flow Area= 0.79 sf

Primary OutFlow Max=0.00 cfs @ 11.89 hrs HW=668.31' TW=668.53' (Dynamic Tailwater)
↑1=Culvert (Controls 0.00 cfs)

Pond 11P: CB#1

Hydrograph

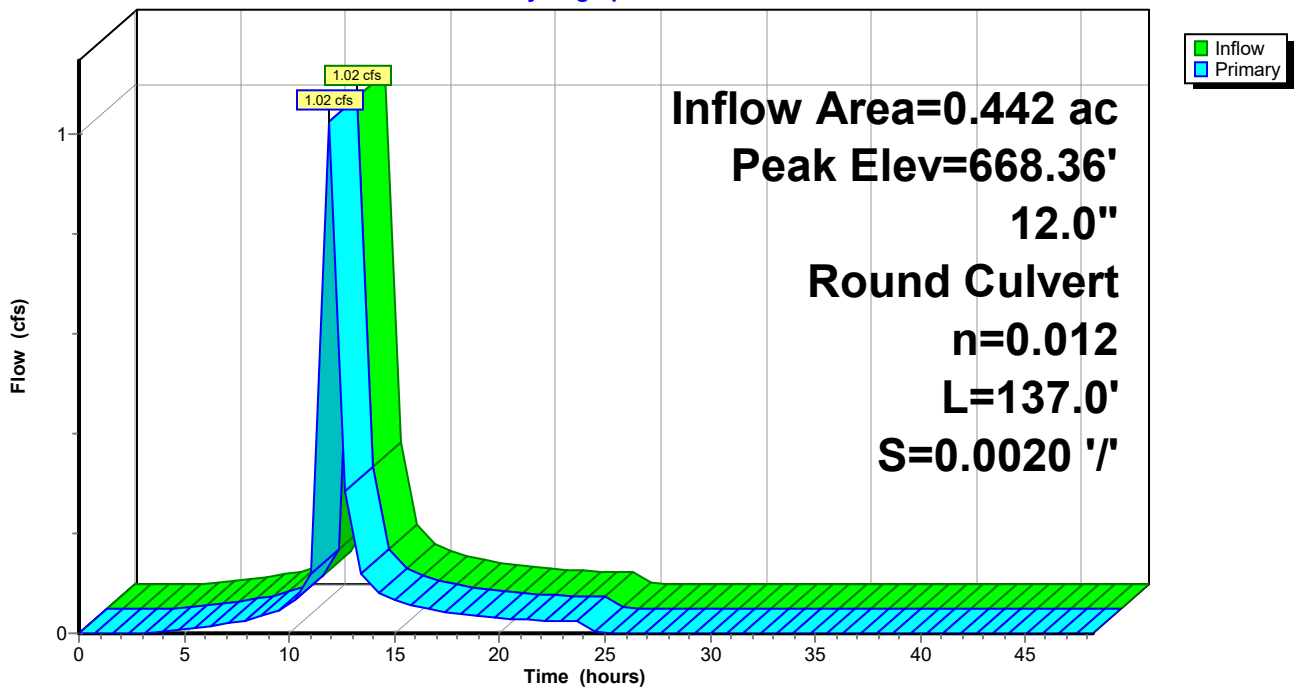

Plug Power - Proposed Conditions 5-15-21

Type II 24-hr 100-yr Rainfall=5.01"

Prepared by {enter your company name here}

Printed 5/20/2021

HydroCAD® 10.10-5a s/n 11585 © 2020 HydroCAD Software Solutions LLC

Page 51

Summary for Pond 13P: CB#3

Inflow Area = 0.724 ac, 59.47% Impervious, Inflow Depth = 3.98" for 100-yr event
Inflow = 1.63 cfs @ 11.89 hrs, Volume= 0.240 af
Outflow = 1.63 cfs @ 11.89 hrs, Volume= 0.240 af, Atten= 0%, Lag= 0.0 min
Primary = 1.63 cfs @ 11.89 hrs, Volume= 0.240 af

Routing by Dyn-Stor-Ind method, Time Span= 0.00-48.19 hrs, dt= 0.79 hrs / 2

Peak Elev= 668.58' @ 11.95 hrs

Flood Elev= 672.65'

Device	Routing	Invert	Outlet Devices
#1	Primary	667.14'	12.0" Round Culvert L= 213.0' CPP, square edge headwall, Ke= 0.500 Inlet / Outlet Invert= 667.14' / 666.71' S= 0.0020 '/ Cc= 0.900 n= 0.012, Flow Area= 0.79 sf

Primary OutFlow Max=1.60 cfs @ 11.89 hrs HW=668.53' TW=668.07' (Dynamic Tailwater)
↑1=Culvert (Outlet Controls 1.60 cfs @ 2.03 fps)

Pond 13P: CB#3

Hydrograph

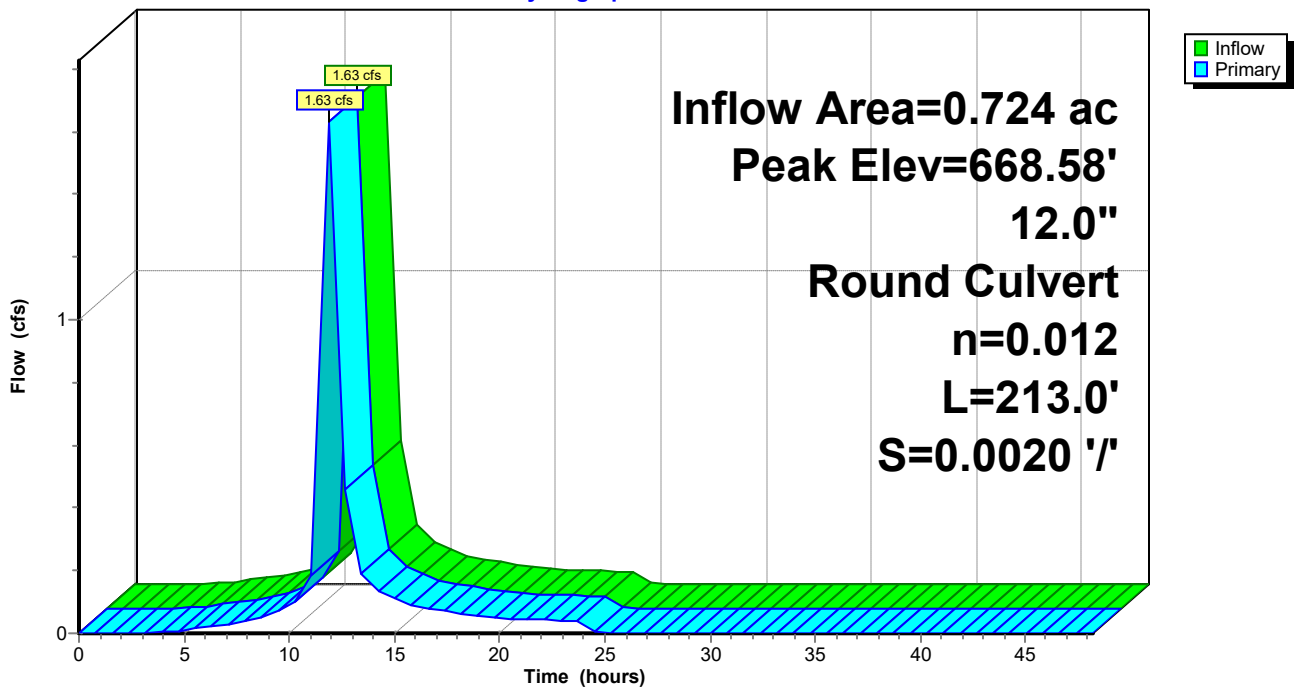

Plug Power - Proposed Conditions 5-15-21

Type II 24-hr 100-yr Rainfall=5.01"

Prepared by {enter your company name here}

Printed 5/20/2021

HydroCAD® 10.10-5a s/n 11585 © 2020 HydroCAD Software Solutions LLC

Page 52

Summary for Pond 15P: CB#5

Inflow Area = 3.805 ac, 39.15% Impervious, Inflow Depth = 3.57" for 100-yr event
 Inflow = 6.15 cfs @ 12.03 hrs, Volume= 1.131 af
 Outflow = 6.15 cfs @ 12.03 hrs, Volume= 1.131 af, Atten= 0%, Lag= 0.0 min
 Primary = 6.15 cfs @ 12.03 hrs, Volume= 1.131 af

Routing by Dyn-Stor-Ind method, Time Span= 0.00-48.19 hrs, dt= 0.79 hrs / 2
 Peak Elev= 668.12' @ 12.06 hrs
 Flood Elev= 670.95'

Device #	Routing	Invert	Outlet Devices
#1	Primary	666.71'	24.0" Round Culvert L= 180.0' CPP, square edge headwall, Ke= 0.500 Inlet / Outlet Invert= 666.71' / 666.35' S= 0.0020 '/ Cc= 0.900 n= 0.012, Flow Area= 3.14 sf

Primary OutFlow Max=5.50 cfs @ 12.03 hrs HW=668.02' TW=667.07' (Dynamic Tailwater)
 ↑1=Culvert (Barrel Controls 5.50 cfs @ 3.58 fps)

Pond 15P: CB#5

Hydrograph

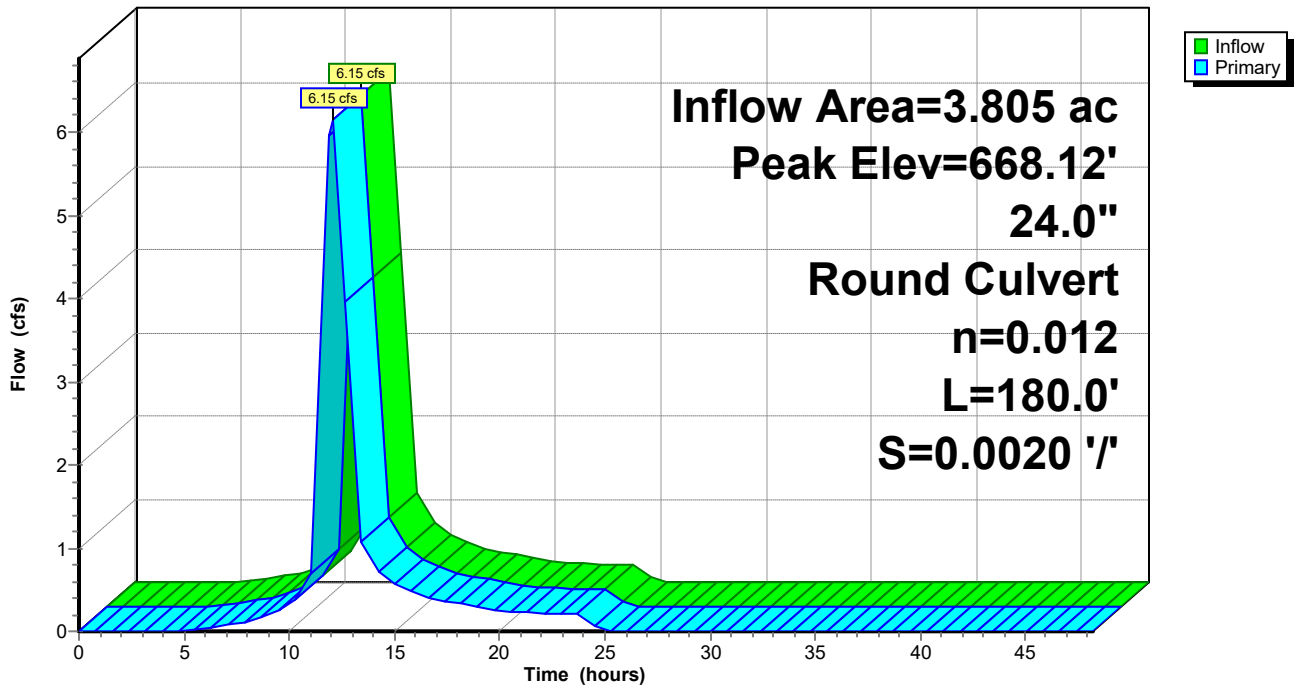

Plug Power - Proposed Conditions 5-15-21

Type II 24-hr 100-yr Rainfall=5.01"

Prepared by {enter your company name here}

Printed 5/20/2021

HydroCAD® 10.10-5a s/n 11585 © 2020 HydroCAD Software Solutions LLC

Page 53

Summary for Pond 19P: YD#22

Inflow Area = 0.624 ac, 27.67% Impervious, Inflow Depth = 3.09" for 100-yr event
Inflow = 0.83 cfs @ 12.11 hrs, Volume= 0.161 af
Outflow = 0.83 cfs @ 12.11 hrs, Volume= 0.161 af, Atten= 0%, Lag= 0.1 min
Primary = 0.83 cfs @ 12.11 hrs, Volume= 0.161 af

Routing by Dyn-Stor-Ind method, Time Span= 0.00-48.19 hrs, dt= 0.79 hrs / 2
Peak Elev= 667.26' @ 12.45 hrs Surf.Area= 1 sf Storage= 2 cf
Flood Elev= 669.45' Surf.Area= 17,680 sf Storage= 5,217 cf

Plug-Flow detention time= (not calculated: outflow precedes inflow)
Center-of-Mass det. time= 0.3 min (828.3 - 828.0)

Volume	Invert	Avail.Storage	Storage Description
#1	665.26'	5,217 cf	Custom Stage Data (Prismatic) Listed below (Recalc)

Elevation (feet)	Surf.Area (sq-ft)	Inc.Store (cubic-feet)	Cum.Store (cubic-feet)
665.26	1	0	0
668.55	1	3	3
669.00	2,745	618	621
669.45	17,680	4,596	5,217

Device	Routing	Invert	Outlet Devices
#1	Primary	665.26'	10.0" Round Culvert L= 70.0' CPP, square edge headwall, Ke= 0.500 Inlet / Outlet Invert= 665.26' / 665.12' S= 0.0020 '/' Cc= 0.900 n= 0.012, Flow Area= 0.55 sf

Primary OutFlow Max=0.62 cfs @ 12.11 hrs HW=667.19' TW=667.11' (Dynamic Tailwater)
↑**1=Culvert** (Outlet Controls 0.62 cfs @ 1.13 fps)

Pond 19P: YD#22

Hydrograph

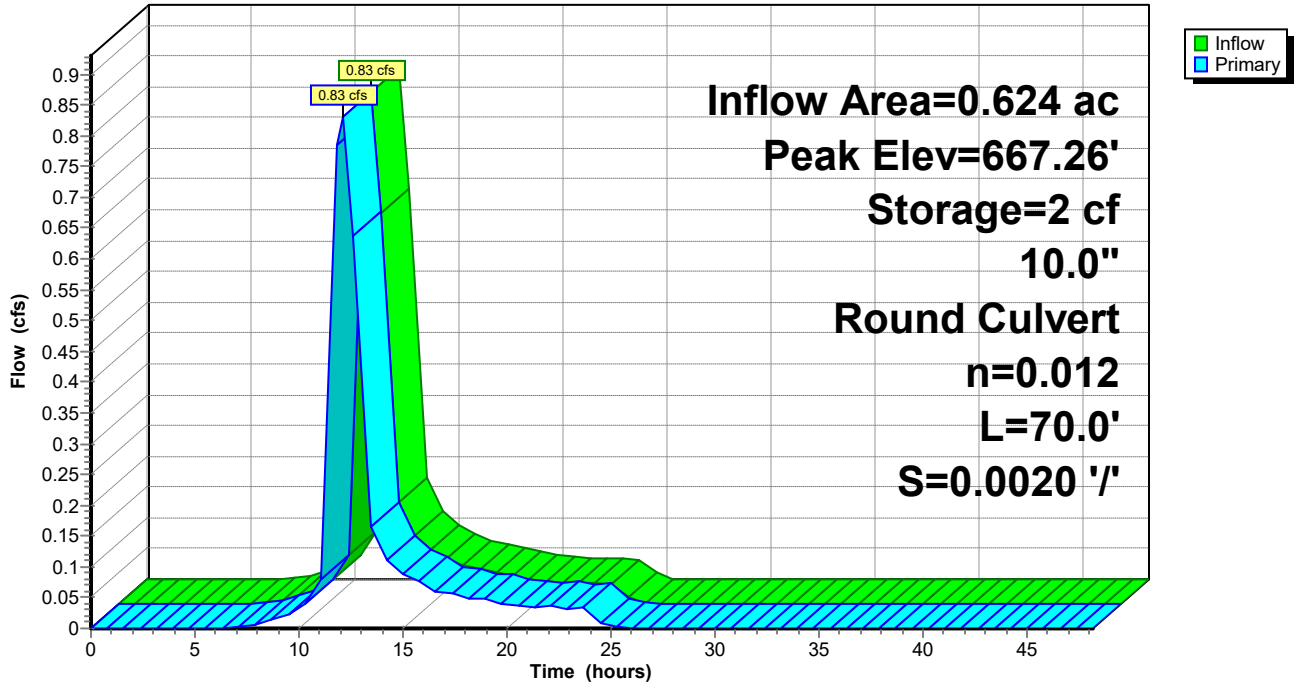

Plug Power - Proposed Conditions 5-15-21

Type II 24-hr 100-yr Rainfall=5.01"

Prepared by {enter your company name here}

Printed 5/20/2021

HydroCAD® 10.10-5a s/n 11585 © 2020 HydroCAD Software Solutions LLC

Page 55

Summary for Pond 21P: Subsurface Detention within Gravel Area

Inflow Area = 22.356 ac, 55.95% Impervious, Inflow Depth = 3.88" for 100-yr event
 Inflow = 39.32 cfs @ 12.00 hrs, Volume= 7.235 af
 Outflow = 35.64 cfs @ 12.14 hrs, Volume= 7.238 af, Atten= 9%, Lag= 8.4 min
 Primary = 14.42 cfs @ 12.16 hrs, Volume= 4.127 af
 Secondary = 9.91 cfs @ 12.16 hrs, Volume= 3.022 af
 Tertiary = 11.33 cfs @ 12.11 hrs, Volume= 1.246 af

Routing by Dyn-Stor-Ind method, Time Span= 0.00-48.19 hrs, dt= 0.79 hrs / 2
 Peak Elev= 667.30' @ 12.19 hrs Surf.Area= 8,430 sf Storage= 9,815 cf
 Flood Elev= 668.95' Surf.Area= 129,465 sf Storage= 49,282 cf

Plug-Flow detention time= 4.2 min calculated for 7.121 af (98% of inflow)
 Center-of-Mass det. time= 4.5 min (800.2 - 795.7)

Volume	Invert	Avail.Storage	Storage Description
#1	664.01'	9,879 cf	Custom Stage Data (Prismatic) Listed below (Recalc) 30,436 cf Overall - 5,739 cf Embedded = 24,697 cf x 40.0% Voids
#2	664.01'	126 cf	24.0" Round Pipe Storage Inside #1 L= 40.0'
#3	664.01'	3,657 cf	24.0" Round Pipe Storage Inside #1 L= 1,164.0' S= 0.0020 '/'
#4	664.01'	1,421 cf	18.0" Round Pipe Storage Inside #1 L= 804.0' S= 0.0020 '/'
#5	665.61'	209 cf	15.0" Round Pipe Storage Inside #1 L= 170.0' S= 0.0020 '/'
#6	665.95'	202 cf	12.0" Round Pipe Storage Inside #1 L= 257.0' S= 0.0020 '/'
#7	666.46'	38 cf	10.0" Round Pipe Storage Inside #1 L= 69.0' S= 0.0020 '/'
#8	666.35'	88 cf	10.0" Round Pipe Storage Inside #1 L= 161.0' S= 0.0020 '/'
#9	668.02'	33,664 cf	Custom Stage Data (Prismatic) Listed below (Recalc) 84,161 cf Overall x 40.0% Voids
		49,282 cf	Total Available Storage

Elevation (feet)	Surf.Area (sq-ft)	Inc.Store (cubic-feet)	Cum.Store (cubic-feet)
664.01	3	0	0
666.67	8,430	11,216	11,216
668.95	8,430	19,220	30,436

Elevation (feet)	Surf.Area (sq-ft)	Inc.Store (cubic-feet)	Cum.Store (cubic-feet)
668.02	0	0	0
668.18	33,970	2,718	2,718
668.45	121,035	20,926	23,643
668.95	121,035	60,518	84,161

Plug Power - Proposed Conditions 5-15-21

Type II 24-hr 100-yr Rainfall=5.01"

Prepared by {enter your company name here}

Printed 5/20/2021

HydroCAD® 10.10-5a s/n 11585 © 2020 HydroCAD Software Solutions LLC

Page 56

Device	Routing	Invert	Outlet Devices
#1	Primary	664.01'	18.0" Round Culvert X 2.00 L= 57.0' CPP, square edge headwall, Ke= 0.500 Inlet / Outlet Invert= 664.01' / 663.90' S= 0.0019' / Cc= 0.900 n= 0.012, Flow Area= 1.77 sf
#2	Secondary	664.01'	18.0" Round Culvert L= 57.0' CPP, square edge headwall, Ke= 0.500 Inlet / Outlet Invert= 664.01' / 663.90' S= 0.0019' / Cc= 0.900 n= 0.012, Flow Area= 1.77 sf
#3	Tertiary	665.95'	18.0" Round Culvert X 3.00 L= 50.0' CPP, square edge headwall, Ke= 0.500 Inlet / Outlet Invert= 665.95' / 665.85' S= 0.0020' / Cc= 0.900 n= 0.012, Flow Area= 1.77 sf

Primary OutFlow Max=16.15 cfs @ 12.16 hrs HW=667.04' TW=666.14' (Dynamic Tailwater)

←1=Culvert (Inlet Controls 16.15 cfs @ 4.57 fps)

Secondary OutFlow Max=9.25 cfs @ 12.16 hrs HW=667.04' TW=665.86' (Dynamic Tailwater)

←2=Culvert (Inlet Controls 9.25 cfs @ 5.24 fps)

Tertiary OutFlow Max=9.90 cfs @ 12.11 hrs HW=667.05' TW=666.50' (Dynamic Tailwater)

←3=Culvert (Barrel Controls 9.90 cfs @ 3.30 fps)

Pond 21P: Subsurface Detention within Gravel Area

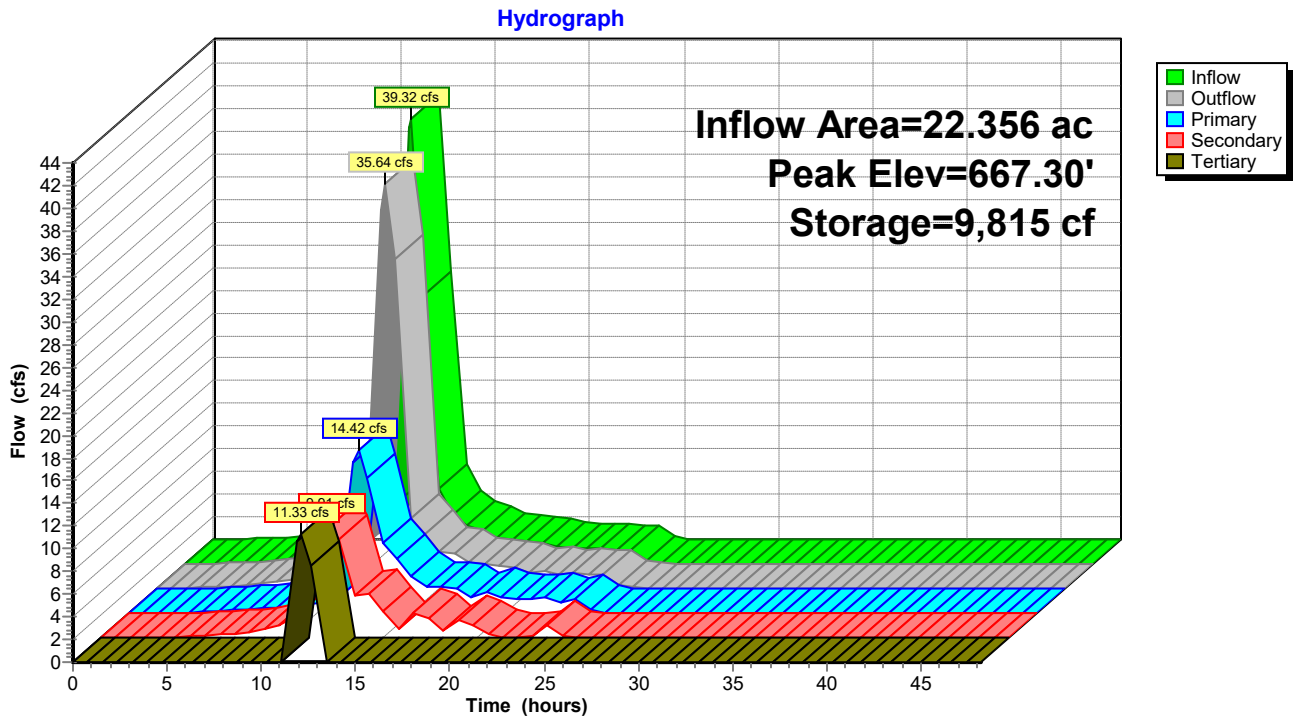

Plug Power - Proposed Conditions 5-15-21

Type II 24-hr 100-yr Rainfall=5.01"

Prepared by {enter your company name here}

Printed 5/20/2021

HydroCAD® 10.10-5a s/n 11585 © 2020 HydroCAD Software Solutions LLC

Page 57

Summary for Pond 22P: Bio-Retention Area

Inflow Area = 24.268 ac, 51.54% Impervious, Inflow Depth = 3.76" for 100-yr event
 Inflow = 25.35 cfs @ 12.34 hrs, Volume= 7.611 af
 Outflow = 24.37 cfs @ 12.83 hrs, Volume= 7.624 af, Atten= 4%, Lag= 29.1 min
 Primary = 19.92 cfs @ 12.92 hrs, Volume= 7.307 af
 Secondary = 4.85 cfs @ 12.64 hrs, Volume= 0.317 af

Routing by Dyn-Stor-Ind method, Time Span= 0.00-48.19 hrs, dt= 0.79 hrs / 2
 Peak Elev= 664.61' @ 12.91 hrs Surf.Area= 59,947 sf Storage= 87,088 cf

Plug-Flow detention time= 249.9 min calculated for 7.501 af (99% of inflow)
 Center-of-Mass det. time= 265.8 min (1,114.2 - 848.4)

Volume	Invert	Avail.Storage	Storage Description
#1	663.00'	95,677 cf	Custom Stage Data (Prismatic) Listed below (Recalc)
Elevation (feet)	Surf.Area (sq-ft)	Inc.Store (cubic-feet)	Cum.Store (cubic-feet)
663.00	48,935	0	0
663.25	50,025	12,370	12,370
663.50	51,115	12,643	25,013
664.00	56,110	26,806	51,819
664.75	60,845	43,858	95,677

Device	Routing	Invert	Outlet Devices
#1	Primary	660.55'	15.0" Round Culvert L= 25.0' CPP, square edge headwall, Ke= 0.500 Inlet / Outlet Invert= 660.55' / 660.50' S= 0.0020 '/' Cc= 0.900 n= 0.012, Flow Area= 1.23 sf
#2	Primary	660.55'	15.0" Round Culvert L= 25.0' CPP, square edge headwall, Ke= 0.500 Inlet / Outlet Invert= 660.55' / 660.50' S= 0.0020 '/' Cc= 0.900 n= 0.012, Flow Area= 1.23 sf
#3	Device 1	660.56'	4.0" Round Culvert L= 5.0' CPP, square edge headwall, Ke= 0.500 Inlet / Outlet Invert= 660.56' / 660.55' S= 0.0020 '/' Cc= 0.900 n= 0.012, Flow Area= 0.09 sf
#4	Device 2	660.56'	4.0" Round Culvert L= 5.0' CPP, square edge headwall, Ke= 0.500 Inlet / Outlet Invert= 660.56' / 660.55' S= 0.0020 '/' Cc= 0.900 n= 0.012, Flow Area= 0.09 sf
#5	Device 3	663.00'	0.500 in/hr Exfiltration X 0.50 over Surface area
#6	Device 4	663.00'	0.500 in/hr Exfiltration X 0.50 over Surface area
#7	Device 3	663.50'	4.0" Horiz. Orifice/Grate X 4.00 C= 0.600 Limited to weir flow at low heads
#8	Device 4	663.50'	4.0" Horiz. Orifice/Grate X 3.00 C= 0.600 Limited to weir flow at low heads
#9	Device 1	664.25'	1.4" x 4.5" Horiz. Orifice/Grate X 72.00 C= 0.600 Limited to weir flow at low heads
#10	Device 2	664.25'	1.4" x 4.5" Horiz. Orifice/Grate X 72.00 C= 0.600 Limited to weir flow at low heads
#11	Secondary	664.50'	100.0' long x 2.0' breadth Broad-Crested Rectangular Weir

Plug Power - Proposed Conditions 5-15-21

Type II 24-hr 100-yr Rainfall=5.01"

Prepared by {enter your company name here}

Printed 5/20/2021

HydroCAD® 10.10-5a s/n 11585 © 2020 HydroCAD Software Solutions LLC

Page 58

Head (feet)	0.20	0.40	0.60	0.80	1.00	1.20	1.40	1.60	1.80	2.00
	2.50	3.00	3.50							
Coef. (English)	2.54	2.61	2.61	2.60	2.66	2.70	2.77	2.89	2.88	
	2.85	3.07	3.20	3.32						

Primary OutFlow Max=17.69 cfs @ 12.92 hrs HW=664.54' TW=661.48' (Dynamic Tailwater)

- 1=Culvert (Passes 8.84 cfs of 10.33 cfs potential flow)
- 3=Culvert (Inlet Controls 0.73 cfs @ 8.42 fps)
- 5=Exfiltration (Passes < 0.34 cfs potential flow)
- 7=Orifice/Grate (Passes < 1.71 cfs potential flow)
- 9=Orifice/Grate (Orifice Controls 8.11 cfs @ 2.57 fps)
- 2=Culvert (Passes 8.84 cfs of 10.33 cfs potential flow)
- 4=Culvert (Inlet Controls 0.73 cfs @ 8.42 fps)
- 6=Exfiltration (Passes < 0.34 cfs potential flow)
- 8=Orifice/Grate (Passes < 1.28 cfs potential flow)
- 10=Orifice/Grate (Orifice Controls 8.11 cfs @ 2.57 fps)

Secondary OutFlow Max=4.85 cfs @ 12.64 hrs HW=664.57' TW=661.52' (Dynamic Tailwater)

- 11=Broad-Crested Rectangular Weir (Weir Controls 4.85 cfs @ 0.68 fps)

Pond 22P: Bio-Retention Area

Hydrograph

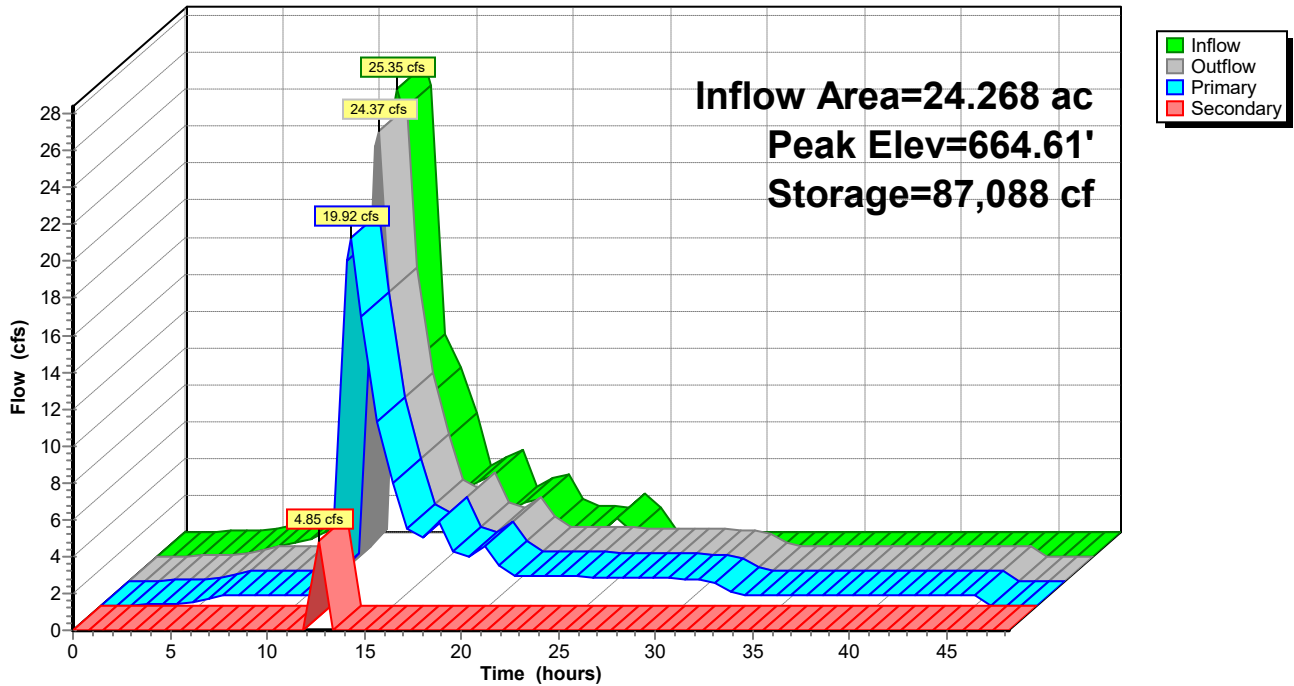

Plug Power - Proposed Conditions 5-15-21

Type II 24-hr 100-yr Rainfall=5.01"

Prepared by {enter your company name here}

Printed 5/20/2021

HydroCAD® 10.10-5a s/n 11585 © 2020 HydroCAD Software Solutions LLC

Page 59

Summary for Pond 25P: YD#11

Inflow Area = 0.893 ac, 53.89% Impervious, Inflow Depth = 3.89" for 100-yr event
Inflow = 1.79 cfs @ 11.93 hrs, Volume= 0.289 af
Outflow = 1.79 cfs @ 11.93 hrs, Volume= 0.289 af, Atten= 0%, Lag= 0.0 min
Primary = 1.79 cfs @ 11.93 hrs, Volume= 0.289 af

Routing by Dyn-Stor-Ind method, Time Span= 0.00-48.19 hrs, dt= 0.79 hrs / 2
Peak Elev= 667.89' @ 12.09 hrs Surf.Area= 1 sf Storage= 2 cf
Flood Elev= 669.70' Surf.Area= 3,725 sf Storage= 1,028 cf

Plug-Flow detention time= (not calculated: outflow precedes inflow)
Center-of-Mass det. time= 0.1 min (795.5 - 795.4)

Volume	Invert	Avail.Storage	Storage Description
#1	666.25'	1,028 cf	Custom Stage Data (Prismatic) Listed below (Recalc)

Elevation (feet)	Surf.Area (sq-ft)	Inc.Store (cubic-feet)	Cum.Store (cubic-feet)
666.25	1	0	0
669.15	1	3	3
669.70	3,725	1,025	1,028

Device	Routing	Invert	Outlet Devices
#1	Primary	666.25'	12.0" Round Culvert L= 170.0' CPP, square edge headwall, Ke= 0.500 Inlet / Outlet Invert= 666.25' / 665.91' S= 0.0020 '/' Cc= 0.900 n= 0.012, Flow Area= 0.79 sf

Primary OutFlow Max=1.18 cfs @ 11.93 hrs HW=667.79' TW=667.58' (Dynamic Tailwater)
1=Culvert (Outlet Controls 1.18 cfs @ 1.50 fps)

Pond 25P: YD#11

Hydrograph

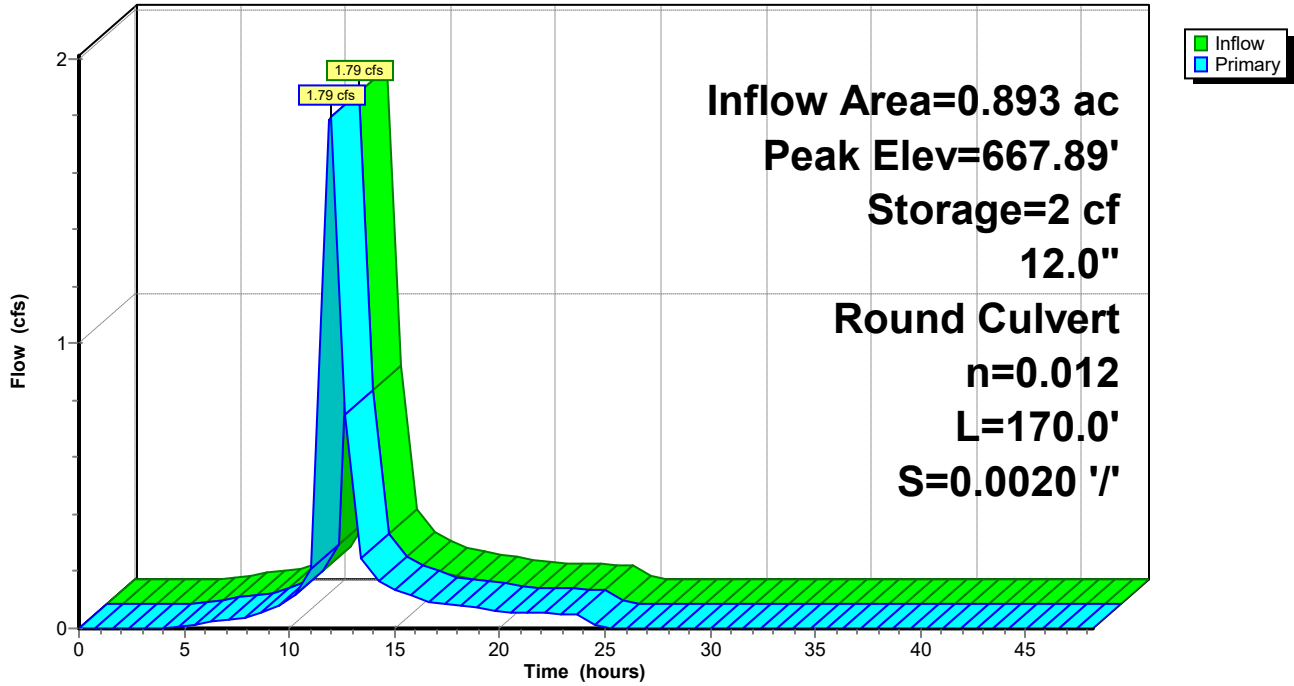

Plug Power - Proposed Conditions 5-15-21

Type II 24-hr 100-yr Rainfall=5.01"

Prepared by {enter your company name here}

Printed 5/20/2021

HydroCAD® 10.10-5a s/n 11585 © 2020 HydroCAD Software Solutions LLC

Page 61

Summary for Pond 27P: CB#4

Inflow Area = 0.946 ac, 62.20% Impervious, Inflow Depth = 3.99" for 100-yr event
Inflow = 1.97 cfs @ 11.93 hrs, Volume= 0.315 af
Outflow = 1.96 cfs @ 11.93 hrs, Volume= 0.315 af, Atten= 0%, Lag= 0.0 min
Primary = 1.96 cfs @ 11.93 hrs, Volume= 0.315 af

Routing by Dyn-Stor-Ind method, Time Span= 0.00-48.19 hrs, dt= 0.79 hrs / 2
Peak Elev= 667.72' @ 12.18 hrs Surf.Area= 4 sf Storage= 7 cf
Flood Elev= 669.15' Surf.Area= 5,345 sf Storage= 1,597 cf

Plug-Flow detention time= (not calculated: outflow precedes inflow)
Center-of-Mass det. time= 0.3 min (791.4 - 791.1)

Volume	Invert	Avail.Storage	Storage Description
#1	665.99'	1,597 cf	Custom Stage Data (Prismatic) Listed below (Recalc)
Elevation (feet)	Surf.Area (sq-ft)	Inc.Store (cubic-feet)	Cum.Store (cubic-feet)
665.99	4	0	0
668.40	4	10	10
669.00	3,160	949	959
669.15	5,345	638	1,597

Device	Routing	Invert	Outlet Devices
#1	Primary	665.99'	12.0" Round Culvert L= 40.0' CPP, square edge headwall, Ke= 0.500 Inlet / Outlet Invert= 665.99' / 665.91' S= 0.0020 '/' Cc= 0.900 n= 0.012, Flow Area= 0.79 sf

Primary OutFlow Max=0.47 cfs @ 11.93 hrs HW=667.60' TW=667.58' (Dynamic Tailwater)
↑**1=Culvert** (Inlet Controls 0.47 cfs @ 0.59 fps)

Pond 27P: CB#4

Hydrograph

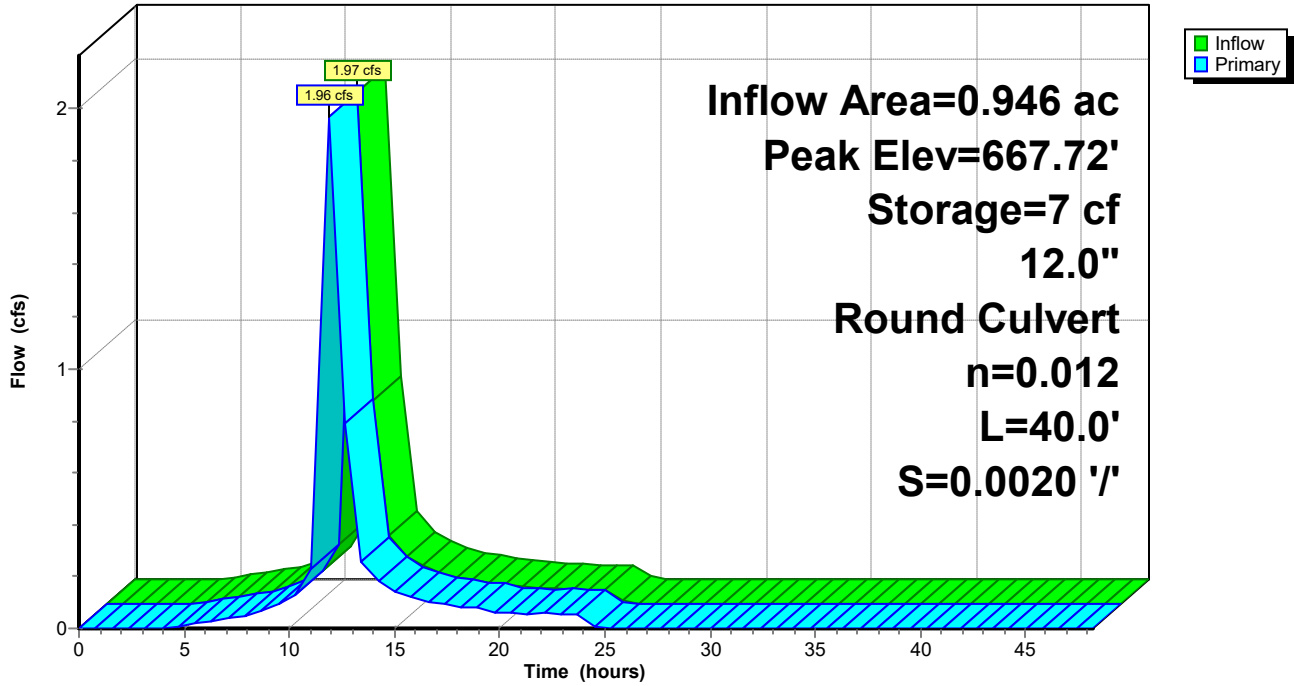

Plug Power - Proposed Conditions 5-15-21

Type II 24-hr 100-yr Rainfall=5.01"

Prepared by {enter your company name here}

Printed 5/20/2021

HydroCAD® 10.10-5a s/n 11585 © 2020 HydroCAD Software Solutions LLC

Page 63

Summary for Pond 28P: CB#15

Inflow Area = 2.230 ac, 65.51% Impervious, Inflow Depth = 4.09" for 100-yr event
 Inflow = 4.81 cfs @ 11.91 hrs, Volume= 0.760 af
 Outflow = 4.80 cfs @ 11.91 hrs, Volume= 0.760 af, Atten= 0%, Lag= 0.0 min
 Primary = 4.80 cfs @ 11.91 hrs, Volume= 0.760 af

Routing by Dyn-Stor-Ind method, Time Span= 0.00-48.19 hrs, dt= 0.79 hrs / 2
 Peak Elev= 667.72' @ 12.21 hrs Surf.Area= 4 sf Storage= 7 cf
 Flood Elev= 669.20' Surf.Area= 4 sf Storage= 13 cf

Plug-Flow detention time= (not calculated: outflow precedes inflow)
 Center-of-Mass det. time= 0.1 min (782.9 - 782.8)

Volume	Invert	Avail.Storage	Storage Description
#1	665.91'	13 cf	Custom Stage Data (Prismatic) Listed below (Recalc)

Elevation (feet)	Surf.Area (sq-ft)	Inc.Store (cubic-feet)	Cum.Store (cubic-feet)
665.91	4	0	0
669.20	4	13	13

Device	Routing	Invert	Outlet Devices
#1	Primary	665.91'	18.0" Round Culvert L= 157.0' CPP, square edge headwall, Ke= 0.500 Inlet / Outlet Invert= 665.91' / 665.60' S= 0.0020 '/' Cc= 0.900 n= 0.012, Flow Area= 1.77 sf

Primary OutFlow Max=3.11 cfs @ 11.91 hrs HW=667.58' TW=667.38' (Dynamic Tailwater)

↑**1=Culvert** (Outlet Controls 3.11 cfs @ 1.97 fps)

Pond 28P: CB#15

Hydrograph

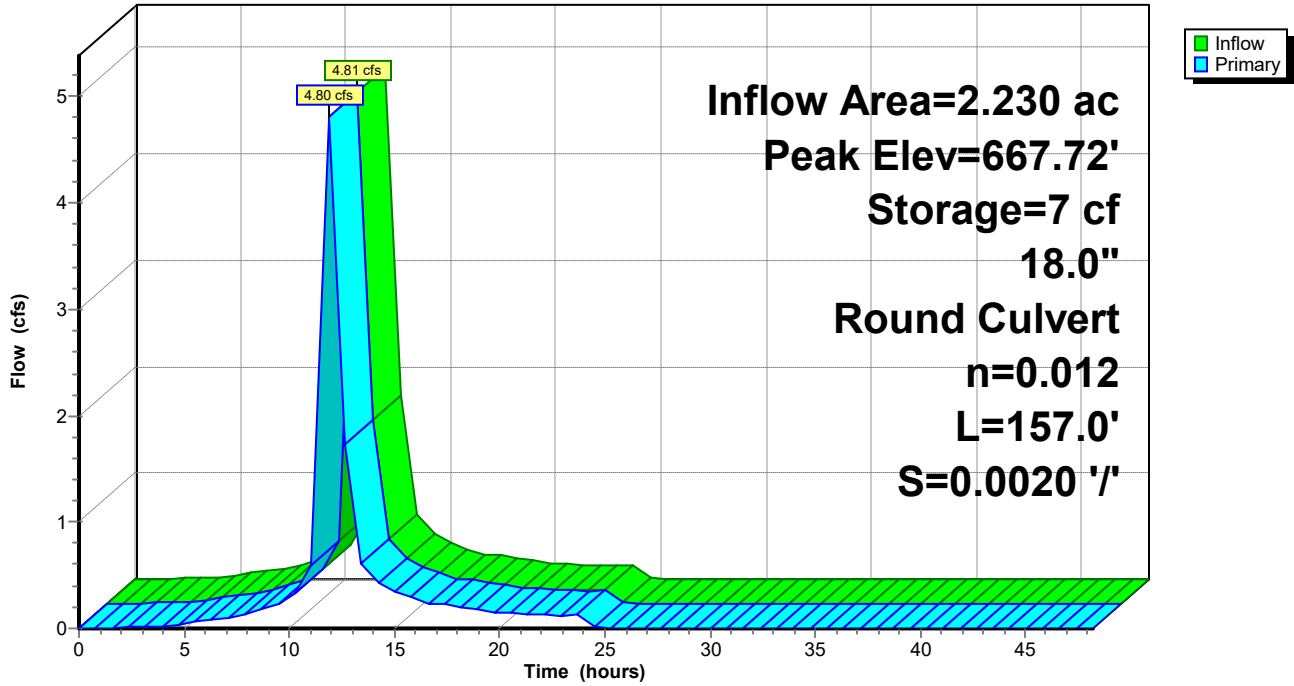

Plug Power - Proposed Conditions 5-15-21

Type II 24-hr 100-yr Rainfall=5.01"

Prepared by {enter your company name here}

Printed 5/20/2021

HydroCAD® 10.10-5a s/n 11585 © 2020 HydroCAD Software Solutions LLC

Page 65

Summary for Pond 29P: Dry Pond

Inflow Area = 0.745 ac, 0.00% Impervious, Inflow Depth = 22.98" for 100-yr event
 Inflow = 12.25 cfs @ 12.12 hrs, Volume= 1.427 af
 Outflow = 10.15 cfs @ 12.65 hrs, Volume= 1.427 af, Atten= 17%, Lag= 32.3 min
 Primary = 10.15 cfs @ 12.65 hrs, Volume= 1.427 af
 Tertiary = 0.00 cfs @ 0.00 hrs, Volume= 0.000 af

Routing by Dyn-Stor-Ind method, Time Span= 0.00-48.19 hrs, dt= 0.79 hrs / 2
 Peak Elev= 665.29' @ 12.79 hrs Surf.Area= 14,188 sf Storage= 25,056 cf

Plug-Flow detention time= 65.7 min calculated for 1.404 af (98% of inflow)
 Center-of-Mass det. time= 66.1 min (810.0 - 743.9)

Volume	Invert	Avail.Storage	Storage Description
#1	662.56'	37,071 cf	Custom Stage Data (Prismatic) Listed below (Recalc)
Elevation (feet)	Surf.Area (sq-ft)	Inc.Store (cubic-feet)	Cum.Store (cubic-feet)
662.56	300	0	0
663.00	6,155	1,420	1,420
663.35	8,635	2,588	4,008
664.00	10,250	6,138	10,146
665.00	12,040	11,145	21,291
666.00	19,520	15,780	37,071

Device	Routing	Invert	Outlet Devices
#1	Primary	662.56'	12.0" Round Culvert L= 30.0' CPP, square edge headwall, Ke= 0.500 Inlet / Outlet Invert= 662.56' / 662.50' S= 0.0020 '/' Cc= 0.900 n= 0.012, Flow Area= 0.79 sf
#2	Primary	662.56'	12.0" Round Culvert L= 30.0' CPP, square edge headwall, Ke= 0.500 Inlet / Outlet Invert= 662.56' / 662.50' S= 0.0020 '/' Cc= 0.900 n= 0.012, Flow Area= 0.79 sf
#3	Device 1	662.56'	3.0" Vert. Orifice/Grate C= 0.600 Limited to weir flow at low heads
#4	Device 2	662.56'	3.0" Vert. Orifice/Grate C= 0.600 Limited to weir flow at low heads
#5	Device 1	663.06'	6.0" Vert. Orifice/Grate C= 0.600 Limited to weir flow at low heads
#6	Device 2	663.06'	6.0" Vert. Orifice/Grate C= 0.600 Limited to weir flow at low heads
#7	Device 1	665.20'	1.4" x 4.5" Horiz. Orifice/Grate X 72.00 C= 0.600 Limited to weir flow at low heads
#8	Device 2	665.20'	1.4" x 4.5" Horiz. Orifice/Grate X 72.00 C= 0.600 Limited to weir flow at low heads
#9	Tertiary	665.70'	100.0' long x 2.0' breadth Broad-Crested Rectangular Weir Head (feet) 0.20 0.40 0.60 0.80 1.00 1.20 1.40 1.60 1.80 2.00 2.50 3.00 3.50 Coef. (English) 2.54 2.61 2.61 2.60 2.66 2.70 2.77 2.89 2.88 2.85 3.07 3.20 3.32

Plug Power - Proposed Conditions 5-15-21

Prepared by {enter your company name here}

HydroCAD® 10.10-5a s/n 11585 © 2020 HydroCAD Software Solutions LLC

Type II 24-hr 100-yr Rainfall=5.01"

Printed 5/20/2021

Page 66

Primary OutFlow Max=8.81 cfs @ 12.65 hrs HW=665.25' TW=663.02' (Dynamic Tailwater)

- 1=Culvert (Passes 4.40 cfs of 5.50 cfs potential flow)
- 3=Orifice/Grate (Orifice Controls 0.35 cfs @ 7.20 fps)
- 5=Orifice/Grate (Orifice Controls 1.32 cfs @ 6.71 fps)
- 7=Orifice/Grate (Weir Controls 2.73 cfs @ 0.74 fps)
- 2=Culvert (Passes 4.40 cfs of 5.50 cfs potential flow)
- 4=Orifice/Grate (Orifice Controls 0.35 cfs @ 7.20 fps)
- 6=Orifice/Grate (Orifice Controls 1.32 cfs @ 6.71 fps)
- 8=Orifice/Grate (Weir Controls 2.73 cfs @ 0.74 fps)

Tertiary OutFlow Max=0.00 cfs @ 0.00 hrs HW=662.56' TW=662.30' (Dynamic Tailwater)

- 9=Broad-Crested Rectangular Weir (Controls 0.00 cfs)

Pond 29P: Dry Pond

Hydrograph

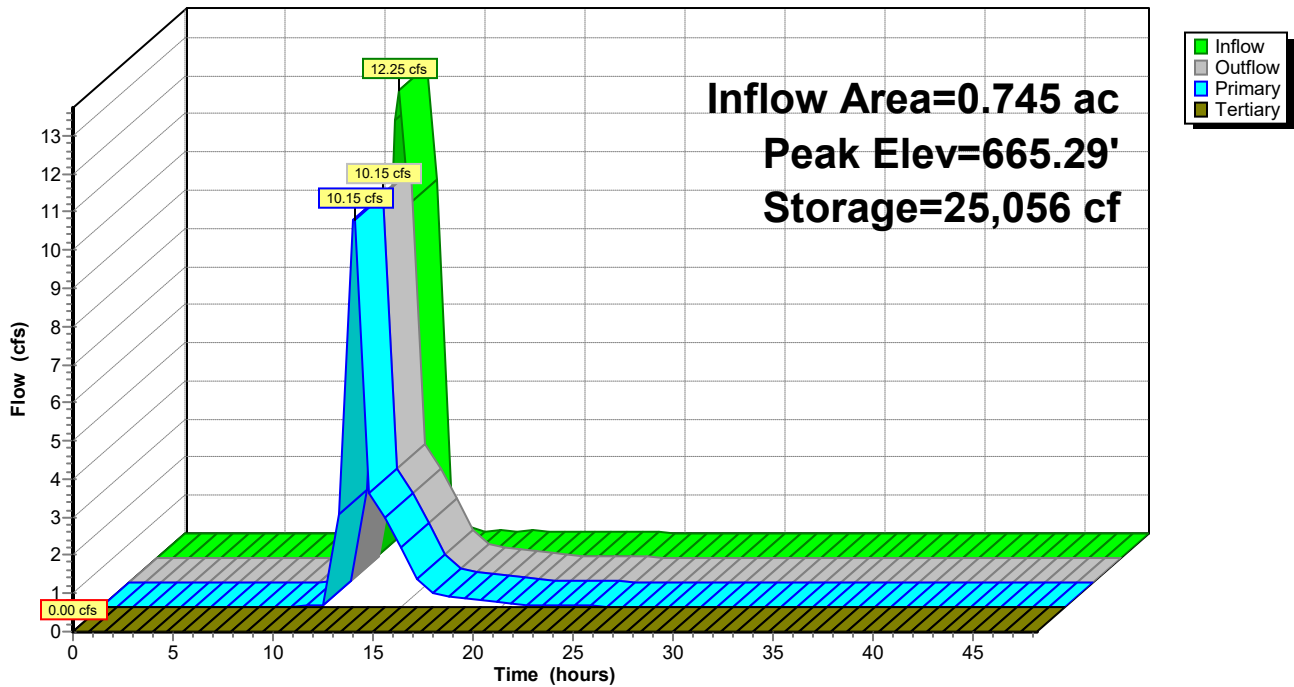

Plug Power - Proposed Conditions 5-15-21

Type II 24-hr 100-yr Rainfall=5.01"

Prepared by {enter your company name here}

Printed 5/20/2021

HydroCAD® 10.10-5a s/n 11585 © 2020 HydroCAD Software Solutions LLC

Page 67

Summary for Pond 31P: CB#18

Inflow Area = 2.692 ac, 56.86% Impervious, Inflow Depth = 3.90" for 100-yr event
 Inflow = 5.38 cfs @ 11.93 hrs, Volume= 0.875 af
 Outflow = 5.38 cfs @ 11.93 hrs, Volume= 0.875 af, Atten= 0%, Lag= 0.0 min
 Primary = 5.38 cfs @ 11.93 hrs, Volume= 0.875 af

Routing by Dyn-Stor-Ind method, Time Span= 0.00-48.19 hrs, dt= 0.79 hrs / 2
 Peak Elev= 667.52' @ 12.21 hrs Surf.Area= 4 sf Storage= 8 cf
 Flood Elev= 669.45' Surf.Area= 9,895 sf Storage= 3,378 cf

Plug-Flow detention time= (not calculated: outflow precedes inflow)
 Center-of-Mass det. time= 0.1 min (789.4 - 789.2)

Volume	Invert	Avail.Storage	Storage Description
#1	665.60'	3,378 cf	Custom Stage Data (Prismatic) Listed below (Recalc)
Elevation (feet)	Surf.Area (sq-ft)	Inc.Store (cubic-feet)	Cum.Store (cubic-feet)
665.60	4	0	0
668.55	4	12	12
669.00	2,530	570	582
669.45	9,895	2,796	3,378

Device	Routing	Invert	Outlet Devices
#1	Primary	665.60'	18.0" Round Culvert L= 83.0' CPP, square edge headwall, Ke= 0.500 Inlet / Outlet Invert= 665.60' / 665.43' S= 0.0020 '/' Cc= 0.900 n= 0.012, Flow Area= 1.77 sf

Primary OutFlow Max=0.00 cfs @ 11.93 hrs HW=667.38' TW=667.39' (Dynamic Tailwater)
 ↑1=Culvert (Controls 0.00 cfs)

Pond 31P: CB#18

Hydrograph

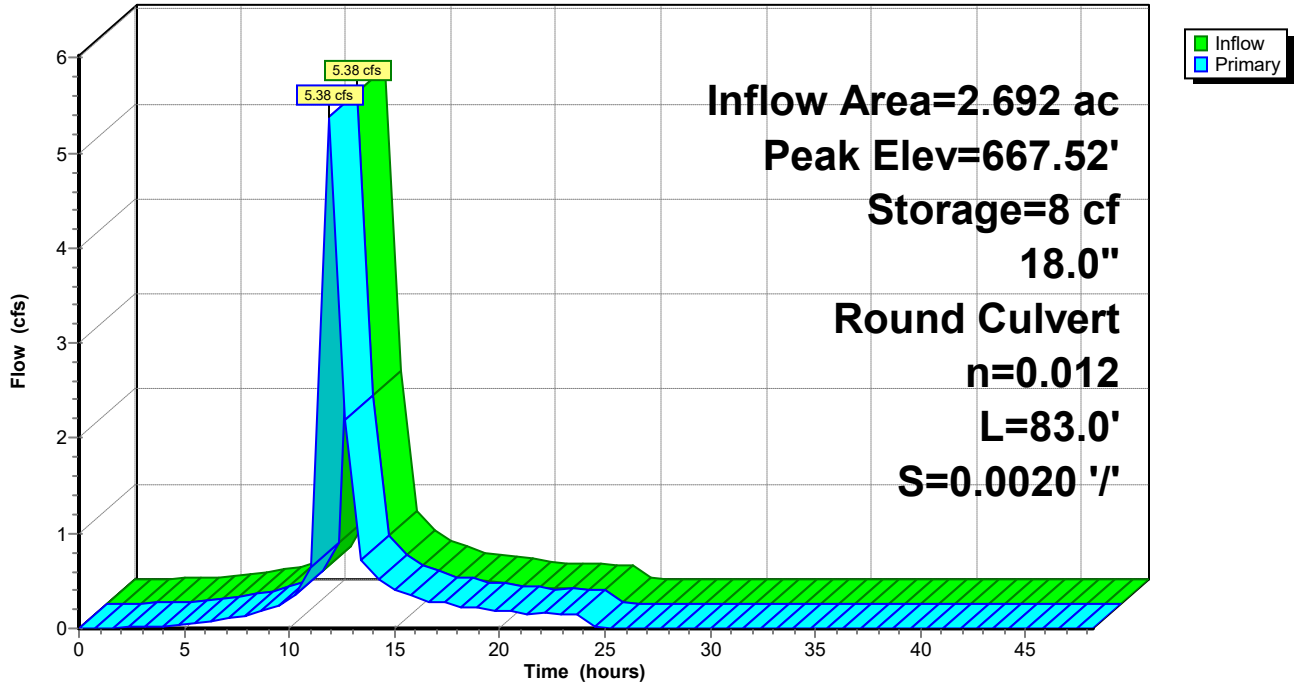

Plug Power - Proposed Conditions 5-15-21

Type II 24-hr 100-yr Rainfall=5.01"

Prepared by {enter your company name here}

Printed 5/20/2021

HydroCAD® 10.10-5a s/n 11585 © 2020 HydroCAD Software Solutions LLC

Page 69

Summary for Pond 33P: CB#26

Inflow Area = 0.831 ac, 69.35% Impervious, Inflow Depth = 4.10" for 100-yr event
 Inflow = 1.77 cfs @ 11.92 hrs, Volume= 0.284 af
 Outflow = 1.77 cfs @ 11.92 hrs, Volume= 0.284 af, Atten= 0%, Lag= 0.0 min
 Primary = 1.77 cfs @ 11.92 hrs, Volume= 0.284 af

Routing by Dyn-Stor-Ind method, Time Span= 0.00-48.19 hrs, dt= 0.79 hrs / 2
 Peak Elev= 667.27' @ 13.65 hrs Surf.Area= 4 sf Storage= 7 cf
 Flood Elev= 669.00' Surf.Area= 3,160 sf Storage= 961 cf

Plug-Flow detention time= (not calculated: outflow precedes inflow)
 Center-of-Mass det. time= 0.3 min (787.3 - 786.9)

Volume	Invert	Avail.Storage	Storage Description
#1	665.42'	1,599 cf	Custom Stage Data (Prismatic) Listed below (Recalc)
Elevation (feet)	Surf.Area (sq-ft)	Inc.Store (cubic-feet)	Cum.Store (cubic-feet)
665.42	4	0	0
668.40	4	12	12
669.00	3,160	949	961
669.15	5,345	638	1,599

Device	Routing	Invert	Outlet Devices
#1	Primary	665.42'	12.0" Round Culvert L= 175.0' CPP, square edge headwall, Ke= 0.500 Inlet / Outlet Invert= 665.42' / 665.07' S= 0.0020 '/' Cc= 0.900 n= 0.012, Flow Area= 0.79 sf

Primary OutFlow Max=1.10 cfs @ 11.92 hrs HW=666.58' TW=666.39' (Dynamic Tailwater)
 ↑**1=Culvert** (Outlet Controls 1.10 cfs @ 1.52 fps)

Pond 33P: CB#26

Hydrograph

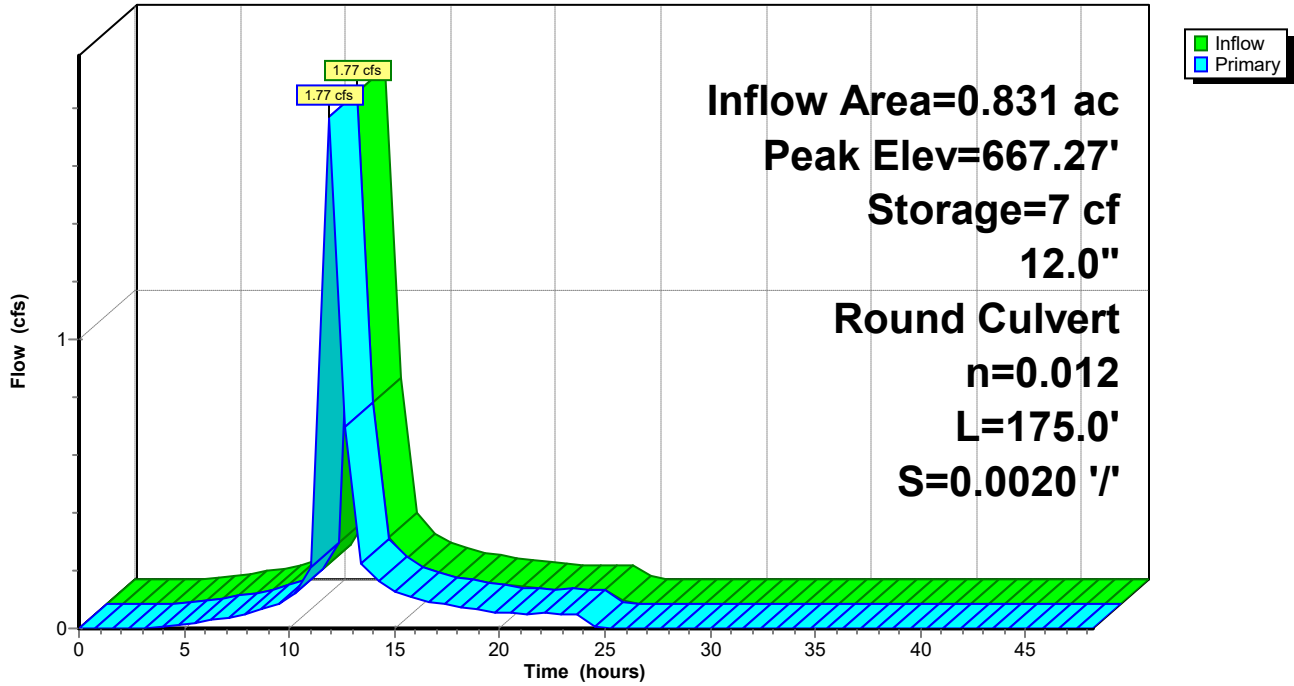

Plug Power - Proposed Conditions 5-15-21

Type II 24-hr 100-yr Rainfall=5.01"

Prepared by {enter your company name here}

Printed 5/20/2021

HydroCAD® 10.10-5a s/n 11585 © 2020 HydroCAD Software Solutions LLC

Page 71

Summary for Pond 37P: CB#28

Inflow Area = 1.256 ac, 61.06% Impervious, Inflow Depth = 3.96" for 100-yr event
 Inflow = 2.53 cfs @ 11.94 hrs, Volume= 0.414 af
 Outflow = 2.53 cfs @ 11.94 hrs, Volume= 0.414 af, Atten= 0%, Lag= 0.0 min
 Primary = 2.53 cfs @ 11.94 hrs, Volume= 0.414 af

Routing by Dyn-Stor-Ind method, Time Span= 0.00-48.19 hrs, dt= 0.79 hrs / 2
 Peak Elev= 666.97' @ 12.97 hrs Surf.Area= 4 sf Storage= 8 cf
 Flood Elev= 669.75' Surf.Area= 5,170 sf Storage= 1,569 cf

Plug-Flow detention time= (not calculated: outflow precedes inflow)
 Center-of-Mass det. time= 0.2 min (792.9 - 792.8)

Volume	Invert	Avail.Storage	Storage Description
#1	665.07'	1,569 cf	Custom Stage Data (Prismatic) Listed below (Recalc)
Elevation (feet)	Surf.Area (sq-ft)	Inc.Store (cubic-feet)	Cum.Store (cubic-feet)
665.07	4	0	0
669.15	4	16	16
669.75	5,170	1,552	1,569

Device	Routing	Invert	Outlet Devices
#1	Primary	665.07'	15.0" Round Culvert L= 214.0' CPP, square edge headwall, Ke= 0.500 Inlet / Outlet Invert= 665.07' / 664.64' S= 0.0020 '/' Cc= 0.900 n= 0.012, Flow Area= 1.23 sf

Primary OutFlow Max=1.67 cfs @ 11.94 hrs HW=666.40' TW=666.21' (Dynamic Tailwater)
 ↑**1=Culvert** (Outlet Controls 1.67 cfs @ 1.59 fps)

Pond 37P: CB#28

Hydrograph

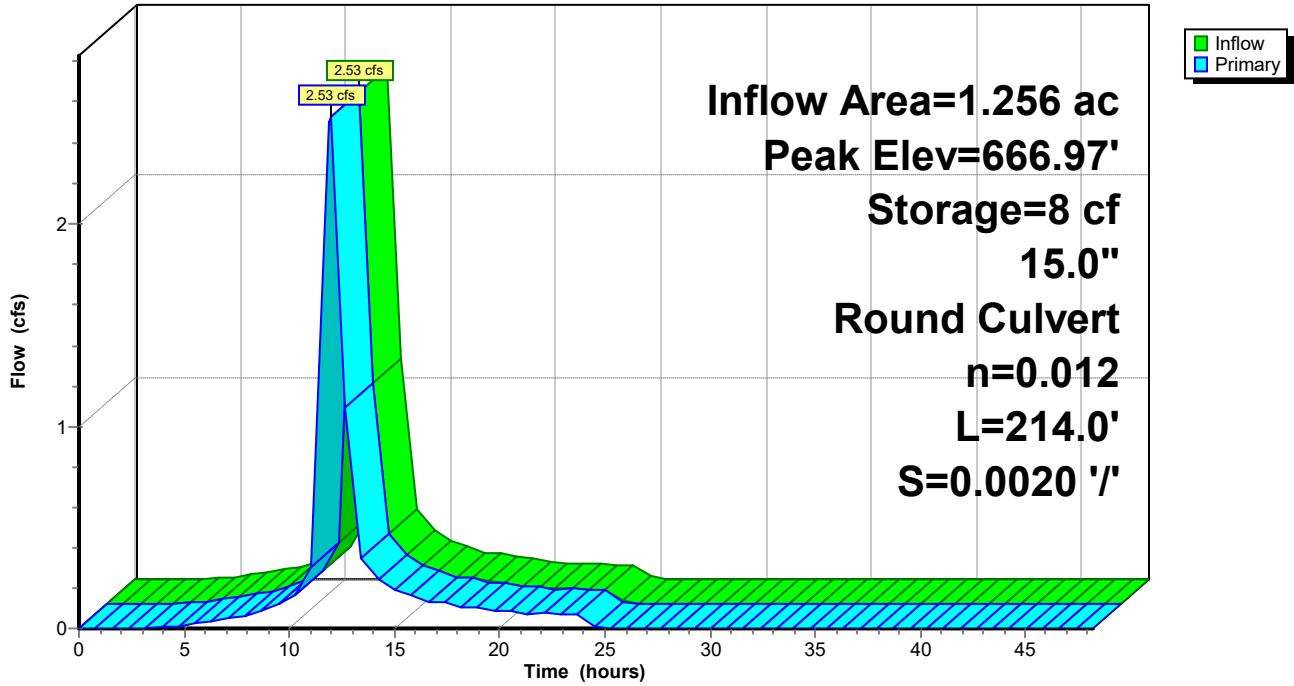

Plug Power - Proposed Conditions 5-15-21

Type II 24-hr 100-yr Rainfall=5.01"

Prepared by {enter your company name here}

Printed 5/20/2021

HydroCAD® 10.10-5a s/n 11585 © 2020 HydroCAD Software Solutions LLC

Page 73

Summary for Pond 39P: CB#30

Inflow Area = 2.166 ac, 42.53% Impervious, Inflow Depth = 3.63" for 100-yr event
 Inflow = 3.88 cfs @ 11.96 hrs, Volume= 0.656 af
 Outflow = 3.88 cfs @ 11.96 hrs, Volume= 0.656 af, Atten= 0%, Lag= 0.0 min
 Primary = 3.88 cfs @ 11.96 hrs, Volume= 0.656 af

Routing by Dyn-Stor-Ind method, Time Span= 0.00-48.19 hrs, dt= 0.79 hrs / 2
 Peak Elev= 667.28' @ 12.89 hrs Surf.Area= 4 sf Storage= 11 cf
 Flood Elev= 668.00' Surf.Area= 220 sf Storage= 19 cf

Plug-Flow detention time= (not calculated: outflow precedes inflow)
 Center-of-Mass det. time= 0.2 min (803.8 - 803.6)

Volume	Invert	Avail.Storage	Storage Description
#1	664.64'	19 cf	Custom Stage Data (Prismatic) Listed below (Recalc)
Elevation (feet)	Surf.Area (sq-ft)	Inc.Store (cubic-feet)	Cum.Store (cubic-feet)
664.64	4	0	0
667.95	4	13	13
668.00	220	6	19

Device	Routing	Invert	Outlet Devices
#1	Primary	664.64'	18.0" Round Culvert L= 150.0' CPP, square edge headwall, Ke= 0.500 Inlet / Outlet Invert= 664.64' / 664.34' S= 0.0020 '/' Cc= 0.900 n= 0.012, Flow Area= 1.77 sf

Primary OutFlow Max=0.00 cfs @ 11.96 hrs HW=666.25' TW=666.79' (Dynamic Tailwater)
 ↑1=Culvert (Controls 0.00 cfs)

Plug Power - Proposed Conditions 5-15-21

Prepared by {enter your company name here}

HydroCAD® 10.10-5a s/n 11585 © 2020 HydroCAD Software Solutions LLC

Type II 24-hr 100-yr Rainfall=5.01"

Printed 5/20/2021

Page 74

Pond 39P: CB#30

Hydrograph

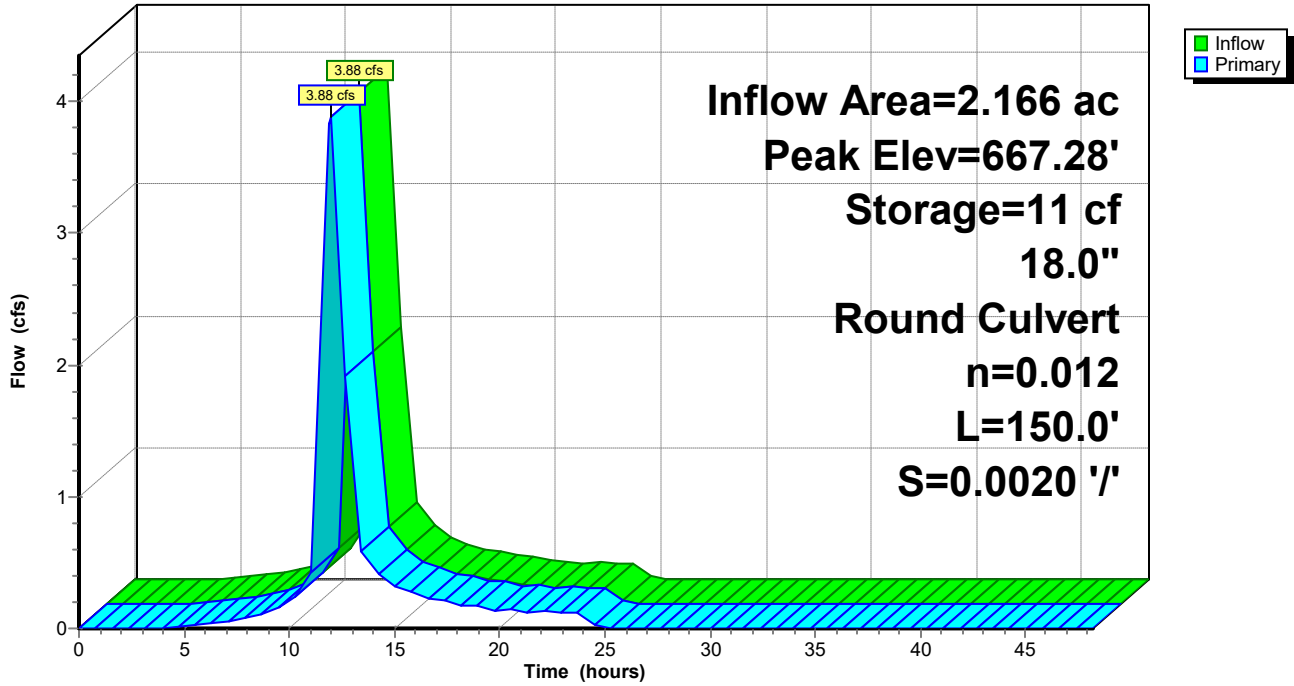

Plug Power - Proposed Conditions 5-15-21

Type II 24-hr 100-yr Rainfall=5.01"

Prepared by {enter your company name here}

Printed 5/20/2021

HydroCAD® 10.10-5a s/n 11585 © 2020 HydroCAD Software Solutions LLC

Page 75

Summary for Pond 41P: CB#32

Inflow Area = 2.889 ac, 56.91% Impervious, Inflow Depth = 3.92" for 100-yr event
 Inflow = 5.35 cfs @ 11.97 hrs, Volume= 0.943 af
 Outflow = 5.34 cfs @ 11.97 hrs, Volume= 0.943 af, Atten= 0%, Lag= 0.0 min
 Primary = 5.34 cfs @ 11.97 hrs, Volume= 0.943 af

Routing by Dyn-Stor-Ind method, Time Span= 0.00-48.19 hrs, dt= 0.79 hrs / 2
 Peak Elev= 666.92' @ 12.32 hrs Surf.Area= 4 sf Storage= 10 cf
 Flood Elev= 668.00' Surf.Area= 5 sf Storage= 15 cf

Plug-Flow detention time= (not calculated: outflow precedes inflow)
 Center-of-Mass det. time= 0.1 min (789.8 - 789.6)

Volume	Invert	Avail.Storage	Storage Description
#1	664.34'	3,522 cf	Custom Stage Data (Prismatic) Listed below (Recalc)

Elevation (feet)	Surf.Area (sq-ft)	Inc.Store (cubic-feet)	Cum.Store (cubic-feet)
664.34	4	0	0
667.95	4	14	14
688.05	345	3,507	3,522

Device	Routing	Invert	Outlet Devices
#1	Primary	664.34'	24.0" Round Culvert L= 166.0' CPP, square edge headwall, Ke= 0.500 Inlet / Outlet Invert= 664.34' / 664.01' S= 0.0020 '/' Cc= 0.900 n= 0.012, Flow Area= 3.14 sf

Primary OutFlow Max=0.00 cfs @ 11.97 hrs HW=666.79' TW=667.08' (Dynamic Tailwater)
 ↑1=Culvert (Controls 0.00 cfs)

Plug Power - Proposed Conditions 5-15-21

Prepared by {enter your company name here}

HydroCAD® 10.10-5a s/n 11585 © 2020 HydroCAD Software Solutions LLC

Type II 24-hr 100-yr Rainfall=5.01"

Printed 5/20/2021

Page 76

Pond 41P: CB#32

Hydrograph

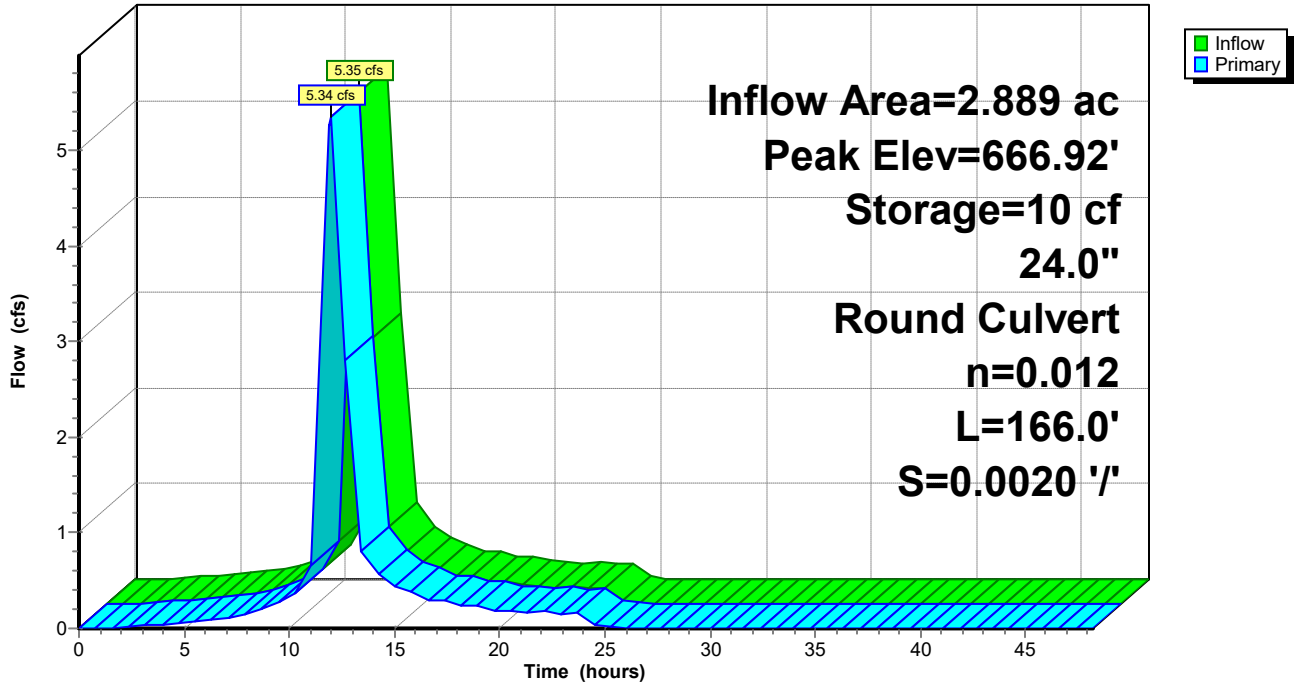

Plug Power - Proposed Conditions 5-15-21

Type II 24-hr 100-yr Rainfall=5.01"

Prepared by {enter your company name here}

Printed 5/20/2021

HydroCAD® 10.10-5a s/n 11585 © 2020 HydroCAD Software Solutions LLC

Page 77

Summary for Pond 44P: CB#24

Inflow Area = 4.895 ac, 67.05% Impervious, Inflow Depth = 4.08" for 100-yr event
Inflow = 10.41 cfs @ 11.91 hrs, Volume= 1.664 af
Outflow = 10.41 cfs @ 11.91 hrs, Volume= 1.664 af, Atten= 0%, Lag= 0.0 min
Primary = 10.41 cfs @ 11.91 hrs, Volume= 1.664 af

Routing by Dyn-Stor-Ind method, Time Span= 0.00-48.19 hrs, dt= 0.79 hrs / 2

Peak Elev= 667.30' @ 12.11 hrs

Flood Elev= 669.85'

Device	Routing	Invert	Outlet Devices
#1	Primary	665.12'	24.0" Round Culvert L= 105.0' CPP, square edge headwall, Ke= 0.500 Inlet / Outlet Invert= 665.12' / 664.91' S= 0.0020 '/ Cc= 0.900 n= 0.012, Flow Area= 3.14 sf

Primary OutFlow Max=4.20 cfs @ 11.91 hrs HW=667.18' TW=667.09' (Dynamic Tailwater)
↑1=Culvert (Outlet Controls 4.20 cfs @ 1.61 fps)

Pond 44P: CB#24

Hydrograph

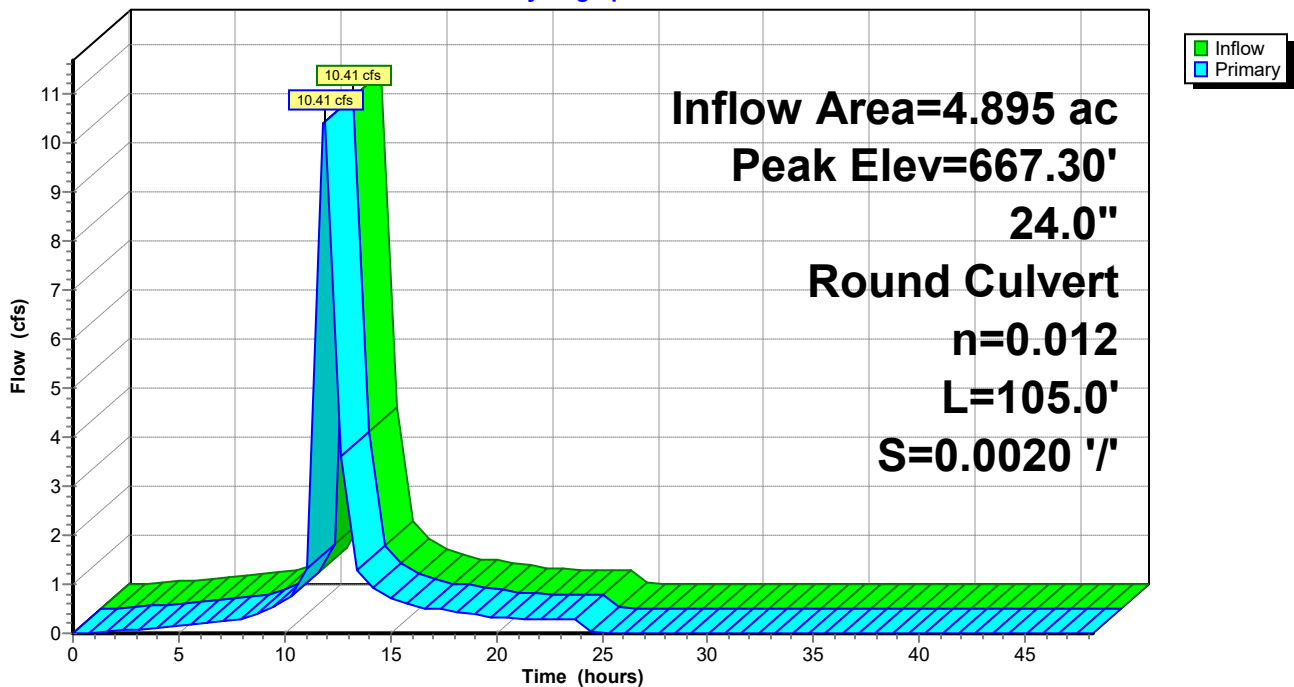

Plug Power - Proposed Conditions 5-15-21

Type II 24-hr 100-yr Rainfall=5.01"

Prepared by {enter your company name here}

Printed 5/20/2021

HydroCAD® 10.10-5a s/n 11585 © 2020 HydroCAD Software Solutions LLC

Page 78

Summary for Pond 46P: CB#20

Inflow Area = 3.433 ac, 66.17% Impervious, Inflow Depth = 4.09" for 100-yr event
Inflow = 7.36 cfs @ 11.91 hrs, Volume= 1.170 af
Outflow = 7.36 cfs @ 11.91 hrs, Volume= 1.170 af, Atten= 0%, Lag= 0.0 min
Primary = 7.36 cfs @ 11.91 hrs, Volume= 1.170 af

Routing by Dyn-Stor-Ind method, Time Span= 0.00-48.19 hrs, dt= 0.79 hrs / 2

Peak Elev= 667.52' @ 12.16 hrs

Flood Elev= 669.85'

Device	Routing	Invert	Outlet Devices
#1	Primary	665.43'	24.0" Round Culvert L= 157.0' CPP, square edge headwall, Ke= 0.500 Inlet / Outlet Invert= 665.43' / 665.12' S= 0.0020 '/ Cc= 0.900 n= 0.012, Flow Area= 3.14 sf

Primary OutFlow Max=5.41 cfs @ 11.91 hrs HW=667.39' TW=667.18' (Dynamic Tailwater)
↑1=Culvert (Outlet Controls 5.41 cfs @ 2.18 fps)

Pond 46P: CB#20

Hydrograph

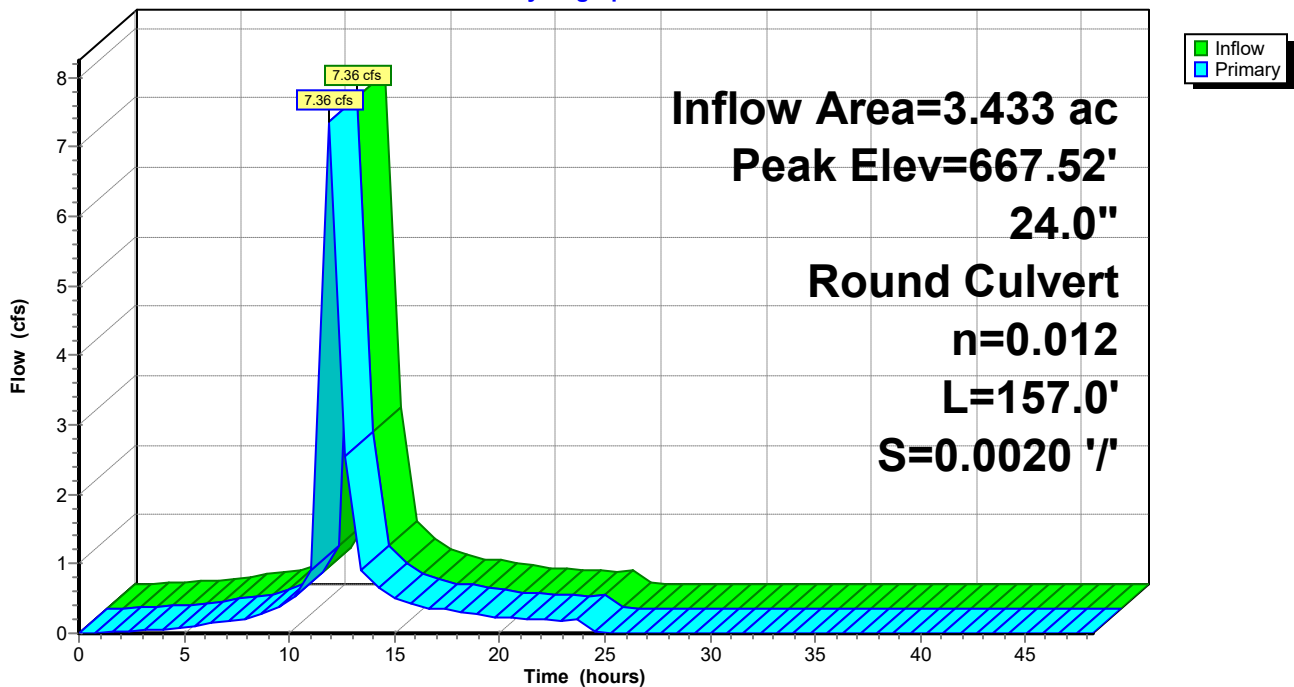

Plug Power - Proposed Conditions 5-15-21

Type II 24-hr 100-yr Rainfall=5.01"

Prepared by {enter your company name here}

Printed 5/20/2021

HydroCAD® 10.10-5a s/n 11585 © 2020 HydroCAD Software Solutions LLC

Page 79

Summary for Pond 50P: YD#8

Inflow Area = 2.660 ac, 32.37% Impervious, Inflow Depth = 3.44" for 100-yr event
 Inflow = 3.83 cfs @ 12.14 hrs, Volume= 0.762 af
 Outflow = 3.83 cfs @ 12.14 hrs, Volume= 0.762 af, Atten= 0%, Lag= 0.0 min
 Primary = 3.83 cfs @ 12.14 hrs, Volume= 0.762 af

Routing by Dyn-Stor-Ind method, Time Span= 0.00-48.19 hrs, dt= 0.79 hrs / 2
 Peak Elev= 668.46' @ 12.10 hrs Surf.Area= 1 sf Storage= 2 cf
 Flood Elev= 669.90' Surf.Area= 8,385 sf Storage= 3,357 cf

Plug-Flow detention time= (not calculated: outflow precedes inflow)
 Center-of-Mass det. time= 0.0 min (818.9 - 818.8)

Volume	Invert	Avail.Storage	Storage Description
#1	666.95'	3,357 cf	Custom Stage Data (Prismatic) Listed below (Recalc)

Elevation (feet)	Surf.Area (sq-ft)	Inc.Store (cubic-feet)	Cum.Store (cubic-feet)
666.95	1	0	0
669.10	1	2	2
669.90	8,385	3,354	3,357

Device	Routing	Invert	Outlet Devices
#1	Primary	666.95'	18.0" Round Culvert L= 122.0' CPP, square edge headwall, Ke= 0.500 Inlet / Outlet Invert= 666.95' / 666.71' S= 0.0020 '/' Cc= 0.900 n= 0.012, Flow Area= 1.77 sf

Primary OutFlow Max=3.43 cfs @ 12.14 hrs HW=668.31' TW=667.98' (Dynamic Tailwater)
 ↑**1=Culvert** (Outlet Controls 3.43 cfs @ 2.67 fps)

Pond 50P: YD#8

Hydrograph

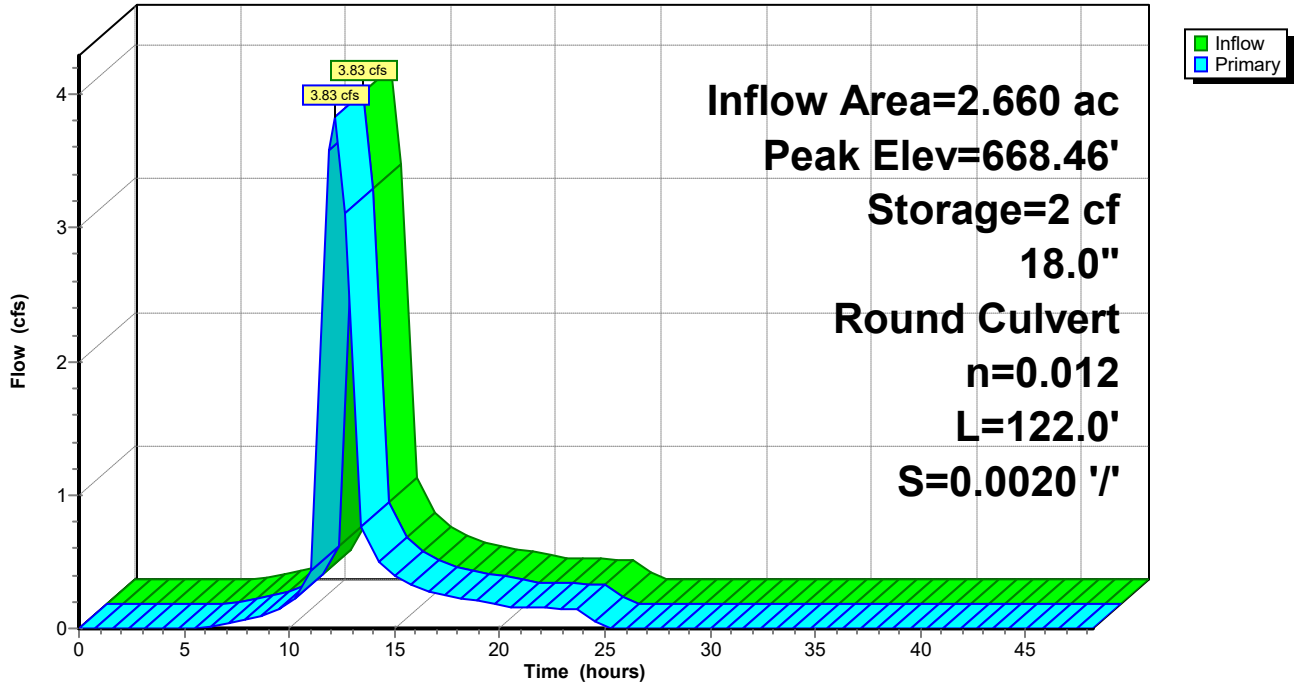

Plug Power - Proposed Conditions 5-15-21

Type II 24-hr 100-yr Rainfall=5.01"

Prepared by {enter your company name here}

Printed 5/20/2021

HydroCAD® 10.10-5a s/n 11585 © 2020 HydroCAD Software Solutions LLC

Page 81

Summary for Pond 51P: YD#6

Inflow Area = 1.879 ac, 30.11% Impervious, Inflow Depth = 3.38" for 100-yr event
 Inflow = 2.63 cfs @ 12.17 hrs, Volume= 0.529 af
 Outflow = 2.63 cfs @ 12.17 hrs, Volume= 0.529 af, Atten= 0%, Lag= 0.0 min
 Primary = 2.63 cfs @ 12.17 hrs, Volume= 0.529 af

Routing by Dyn-Stor-Ind method, Time Span= 0.00-48.19 hrs, dt= 0.79 hrs / 2
 Peak Elev= 668.63' @ 12.36 hrs Surf.Area= 1 sf Storage= 1 cf
 Flood Elev= 669.70' Surf.Area= 7,065 sf Storage= 1,592 cf

Plug-Flow detention time= 0.0 min calculated for 0.520 af (98% of inflow)
 Center-of-Mass det. time= 0.0 min (821.4 - 821.3)

Volume	Invert	Avail.Storage	Storage Description
#1	667.23'	1,592 cf	Custom Stage Data (Prismatic) Listed below (Recalc)

Elevation (feet)	Surf.Area (sq-ft)	Inc.Store (cubic-feet)	Cum.Store (cubic-feet)
667.23	1	0	0
669.25	1	2	2
669.70	7,065	1,590	1,592

Device	Routing	Invert	Outlet Devices
#1	Primary	667.23'	15.0" Round Culvert L= 138.0' CPP, square edge headwall, Ke= 0.500 Inlet / Outlet Invert= 667.23' / 666.95' S= 0.0020 '/' Cc= 0.900 n= 0.012, Flow Area= 1.23 sf

Primary OutFlow Max=2.00 cfs @ 12.17 hrs HW=668.52' TW=668.30' (Dynamic Tailwater)
 ↑**1=Culvert** (Outlet Controls 2.00 cfs @ 1.96 fps)

Pond 51P: YD#6

Hydrograph

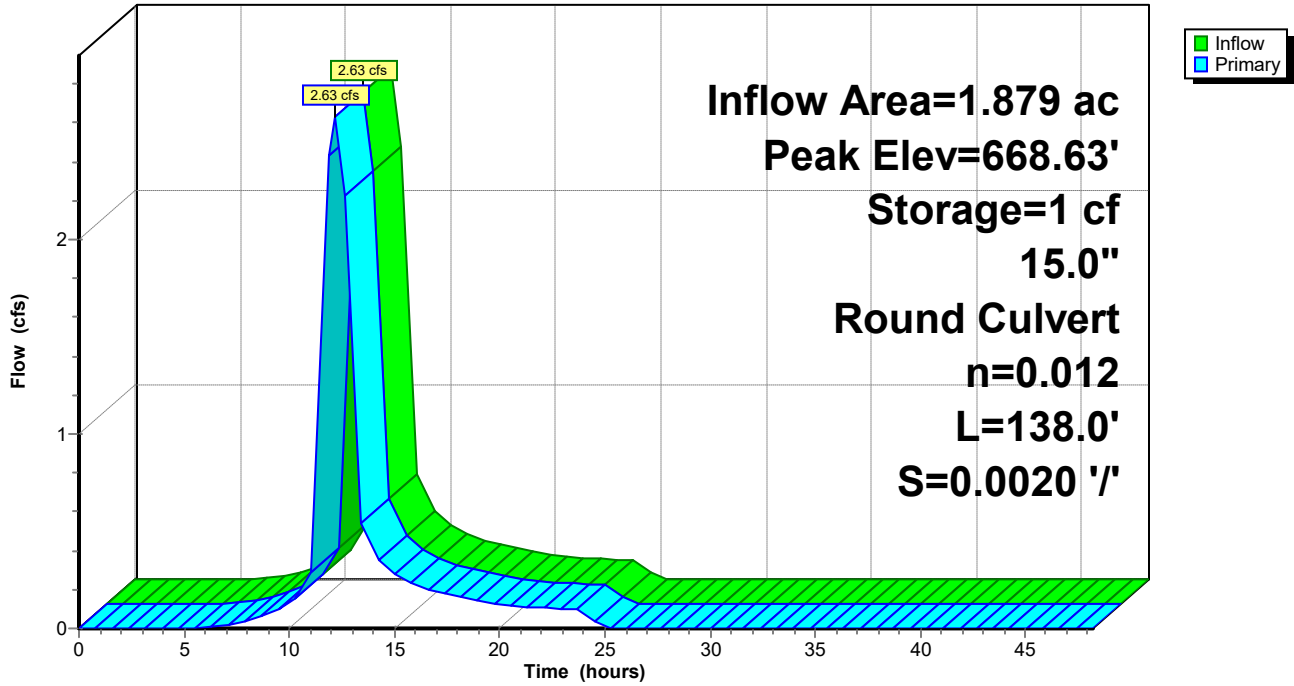

Summary for Link 52L: Total Site Discharge

Inflow Area = 29.096 ac, 42.99% Impervious, Inflow Depth = 4.11" for 100-yr event
Inflow = 34.14 cfs @ 12.86 hrs, Volume= 9.977 af
Primary = 34.14 cfs @ 12.86 hrs, Volume= 9.977 af, Atten= 0%, Lag= 0.0 min

Primary outflow = Inflow, Time Span= 0.00-48.19 hrs, dt= 0.79 hrs

Link 52L: Total Site Discharge

Hydrograph

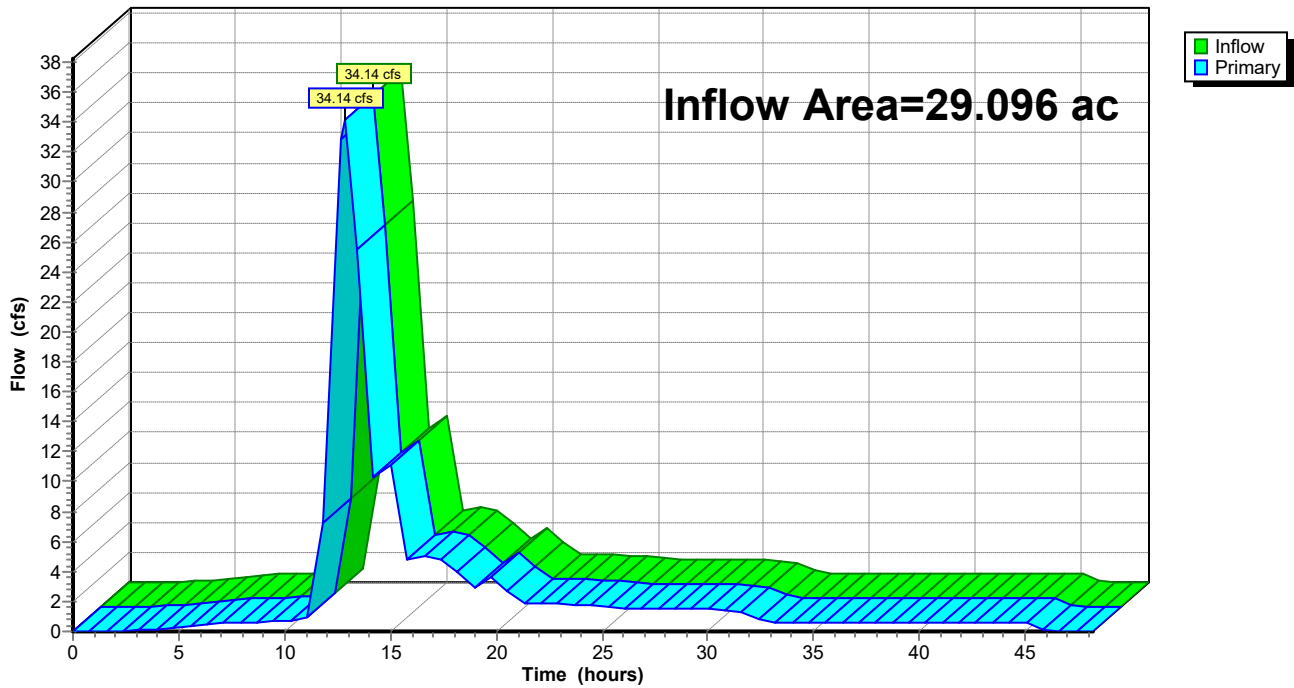

Appendix A-3

Drainage Calculations

WQ_v, RR_v & CP_v Calculations

WATER QUALITY VOLUME (WQV) CALCS:

$$\text{SITE DRAINAGE AREA (ENCL. R.O.W.)} = 29.096 \text{ AC.}$$

$$\text{TOTAL PROP. IMPERVIOUS} = 15.513 \text{ AC.}$$

$$WQV = \frac{(P)(R_v)(A)}{12} \quad \text{WHERE } P = 90\% \text{ ANNUAL RAINFALL EVENTS NO.} = 1.00$$

$$= \frac{(1.00)(0.530)(29.096)}{12}$$

$$R_v = 0.05 + 0.009(I) \quad I = \frac{15.513}{29.096} = 53.3\%$$

$$= 0.05 + 0.009(53.3)$$

$$= 0.530$$

$$= \boxed{1.285 \text{ AC-FT}} \quad A = 29.096 \text{ AC. } I = 15.513 \text{ AC.}$$

RUNOFF REDUCTION VOLUME (RRV)

$$RRV = \frac{(P)(R_v)(A_i)}{12} \quad \text{WHERE } P = 100$$

$$= \frac{(1.00)(0.95)(3.045)}{12}$$

$$R_v = 0.05 + 0.009(I) \quad I = 100\%$$

$$= 0.05 + 0.009(100)$$

$$= 0.95$$

$$= \boxed{0.241 \text{ AC-FT}}$$

$$A_i = (S)(A_{ic}) = (0.2)(15.227) = 3.045 \text{ AC.}$$

S = SPECIFIC REDUCTION FACTOR = 0.2 FOR "D" SOILS
 A_{ic} = AREA OF NEW IMPERVIOUS = 15.227 AC.

EXIST. IMPERVIOUS = 0.280 AC
 PROP. IMPERVIOUS = 15.513 AC.

PERIMETER VEGETATED AREAS OF THE SITE DO NOT RECEIVE RUNOFF FROM THE DEVELOPED SITE AND DRAIN OVERLAND TO EXISTING WETLAND AREAS TO THE NORTH, SOUTH AND WEST OF THE SITE. THESE AREAS CAN THEREFORE BE SUBTRACTED FROM THE CONTRIBUTING AREA FOR THE WQV CALCULATIONS.

$$\text{TOTAL AREA DRAINING OVERLAND OFF SITE} = 4.083 \text{ AC.}$$

∴ THE CONTRIBUTING AREA IS REDUCED TO $29.096 \text{ AC} - 4.083 \text{ AC} = \boxed{25.013 \text{ AC}}$, AND THE WQV IS RECALCULATED:

$$WQ_v = \frac{(P)(R_v)(A)}{12} \quad P = 1.00$$

$$= \frac{(1.00)(0.608)(25,013)}{12}$$

$$= \boxed{1.267 \text{ AC-Ft}}$$

$$R_v = 0.05 + 0.009(T) \\ = 0.05 + 0.009(62.0) \\ = 0.608$$

$$I = \frac{15,513}{25,013} = 62.0\%$$

$$A = 25,013 \text{ AC IMPERVIOUS} = 15,513 \text{ AC}$$

BIO-RETENTION AREA SIZING:

$$A_f = \frac{(WQ_v)(d_f)}{[K](h_f + d_f)(L_f)}$$

$$A_f = \frac{55191(2.5)}{[0.5](0.25 + 2.5)(2)}$$

$$A_f = \frac{137977.5}{2.75} = \boxed{50,174 \text{ Ft}^2}$$

WHERE: $WQ_v = 1.267 \text{ AC-Ft} = 55191 \text{ Ft}^3$

$d_f = \text{DEPTH OF SOIL MEDIA} = 2.5 \text{ Ft}$

$K = \text{HYDRAULIC CONDUCTIVITY} = 0.5 \text{ Ft/DAY}$

$h_f = \text{AVE. HEIGHT OF PONDING} = 0.25 \text{ Ft}$

$L_f = \text{TIME TO FILTER} = 2 \text{ DAYS}$

$A_f = \text{AREA OF BIO-RETENTION REQUIRED}$

BIO-RETENTION AREA PROVIDED = $\boxed{50,275 \text{ Ft}^2}$

WQ_v PROVIDED:

$$A_f = \frac{(WQ_v)(d_f)}{[K](h_f + d_f)(L_f)}$$

$$50,275 = \frac{(WQ_v)(2.5)}{[0.5](0.25 + 2.5)(2)}$$

$$WQ_v = 55,302.5 \text{ Ft}^3 = \boxed{1,270 \text{ AC-Ft}}$$

PER TABLE 3.5 IN THE N.Y.S. STORMWATER MANAGEMENT DESIGN MANUAL, A BIO-RETENTION PRACTICE CAN UTILIZE 40% OF THE WQ_v PROVIDED BY THE TECHNIQUE TOWARDS MEETING THE RR_v REQUIREMENT.

$$\therefore \text{RR}_v \text{ PROVIDED} = (0.40)(1,270 \text{ AC-Ft}) = \boxed{0,508 \text{ AC-Ft}}$$

Gateway - Proposed Conditions Updated Layout 5-8-21

Prepared by {enter your company name here}

HydroCAD® 10.10-5a s/n 11585 © 2020 HydroCAD Software Solutions LLC

Printed 5/14/2021

Area Listing (all nodes)

Area (acres)	CN	Description (subcatchment-numbers)
9.685	80	>75% Grass cover, Good, HSG D (1S, 3S, 10S, 12S, 14S, 18S, 20S, 24S, 26S, 30S, 32S, 36S, 38S, 42S, 48S, 49S, 52S, 53S, 54S, 55S, 56S)
2.105	77	Brush, Fair, HSG D (8S, 57S, 58S)
3.004	80	Gravel Storage Area, Good, HSG D (20S, 42S)
0.867	78	Meadow, non-grazed, HSG D (1S, 3S, 38S)
5.945	98	Paved parking, HSG D (10S, 12S, 14S, 20S, 24S, 26S, 32S, 36S, 38S, 40S, 42S, 48S, 49S)
5.115	98	Roofs, HSG D (10S, 12S, 20S, 24S, 26S, 29S, 42S, 43S, 45S, 48S, 49S)
1.449	98	Unconnected pavement, HSG D (18S, 20S, 30S, 36S, 42S)
0.610	79	Woods, Fair, HSG D (1S, 38S)
0.516	79	Woods/grass comb., Good, HSG D (2S, 4S)
29.096	87	TOTAL AREA

(IMPERVIOUS FOR WQV)

TOTAL IMPERVIOUS = 15,513 AC

STREAM CHANNEL PROTECTION VOLUME (CPV)

AREA = 29.096 AC. $P_{1yr} = 1.82 IN.$ CN = 87

$I_a = \frac{200}{CN} - 2 = \frac{200}{87} - 2 = 0.299$ $I_a/p = \frac{0.299}{1.82} = 0.164$

$CN = \frac{1000}{10+S}$ $87 = \frac{1000}{10+S}$ $870 + 87S = 1000$ $87S = 130$ $S = 1.49$

$Q_{INCHES} = \frac{(P - 0.2S)^2}{(P + 0.8S)} = \frac{[1.82 - 0.2(1.49)]^2}{1.82 + (0.8)(1.49)} = \frac{2.316}{3.612} = 0.77 IN.$

$T_c = 17.3 \text{ MIN (CN \#11)} + 672' \text{ PIPE FLOW (5.6 MIN)} + 4.0 \text{ MIN CENTER OF MASS GRAVEL} + 32.2 \text{ MIN AVE. TRAVEL TIME SWALE} + 407.4 \text{ MIN. CENTER OF MASS BIO-RETENTION}$

$T_{c \text{ PIPE}} = \frac{672'}{(2' / \text{SEC} \times 60 \text{ SEC} / \text{MIN})} = 5.6 \text{ MIN.}$

$T_c = 466.5 \text{ MIN.} = 7.78 \text{ HR.}$

⇒ USING EXHIBIT 4-11 FROM TR-55 w/ $I_a/p = 0.164$ & $T_c = 7.78 \text{ HR}$
FIND $g_u = 70 \text{ CSM/IN.}$

⇒ USING FIGURE 8.5 FROM THE NYS STORMWATER MANAGEMENT DESIGN MANUAL FOR $T = 24 \text{ HRS.}$ & $g_u = 70$, FIND $g_o/g_i = 0.225$

⇒ DETERMINE CHANNEL PROTECTION STORAGE (V_s) OR (CPV):

$V_s/V_r = 0.682 - 1.43(g_o/g_i) + 1.64(g_o/g_i)^2 - 0.804(g_o/g_i)^3$

$= 0.682 - 1.43(0.225) + 1.64(0.225)^2 - 0.804(0.225)^3$

$= 0.682 - 0.322 + 0.083 - 0.009 = 0.434$

SOLVE FOR $V_s = CPV = 0.434 V_r$ WHERE $V_r = 0.77 IN$

$CPV = (0.434)(0.77 IN)(1 \text{ FT} / 12 IN)(43560 \text{ FT}^2 / \text{AC})(29.096 \text{ AC}) = 32,296 \text{ FT}^3$

$CPV \text{ PROVIDED} = 3,785 \text{ FT}^3 \text{ (GRAVEL)} + 3118 \text{ FT}^3 \text{ M. SWALE} + 3,888 \text{ FT}^3 \text{ W. SWALE} + 42,072 \text{ FT}^3 \text{ BIO-RET} = 52,863 \text{ FT}^3$

$= 1,214 \text{ AC-FT}$

Exhibit 4-II: Unit peak discharge (q_u) for SCS type II rainfall distribution

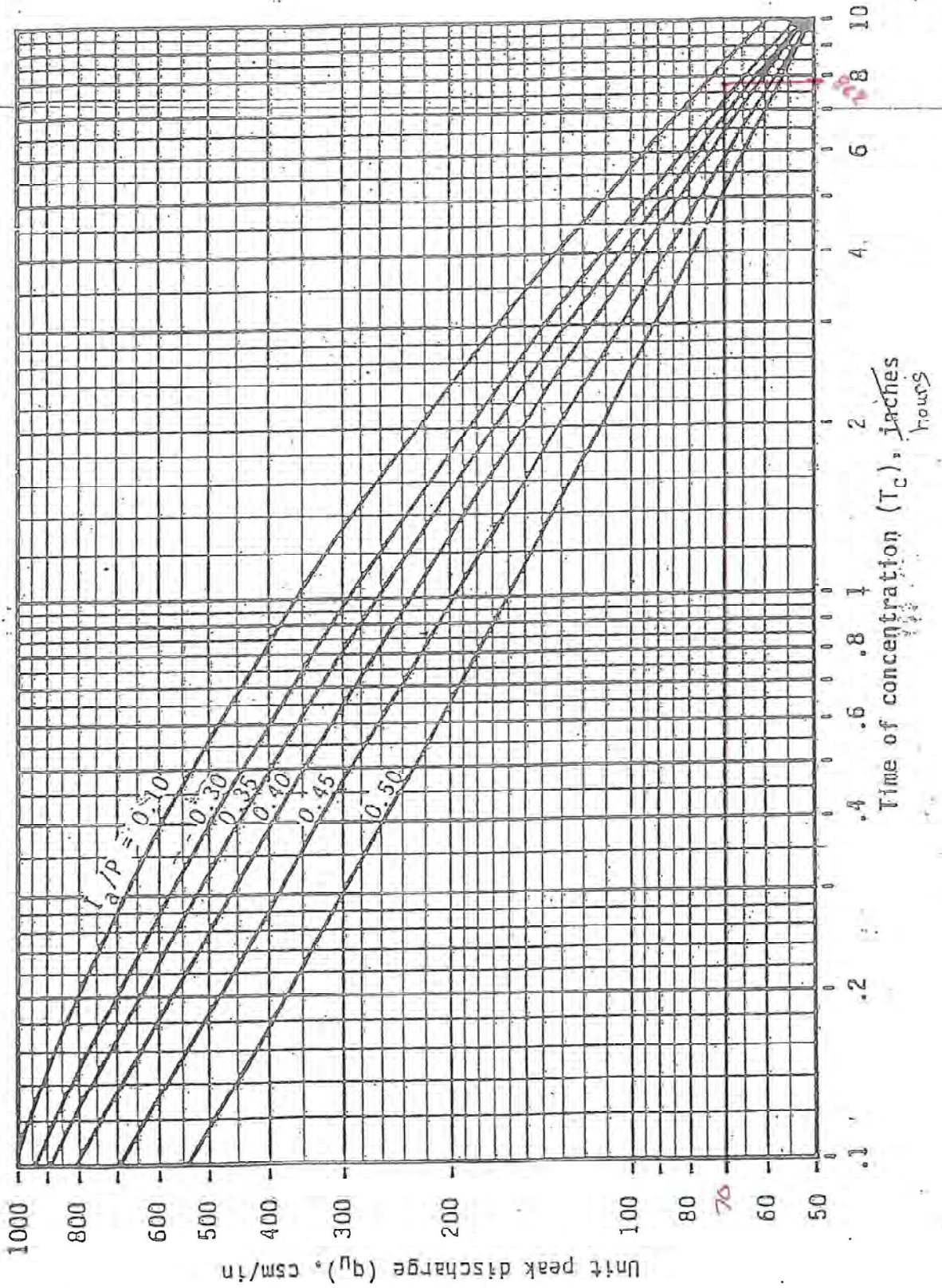
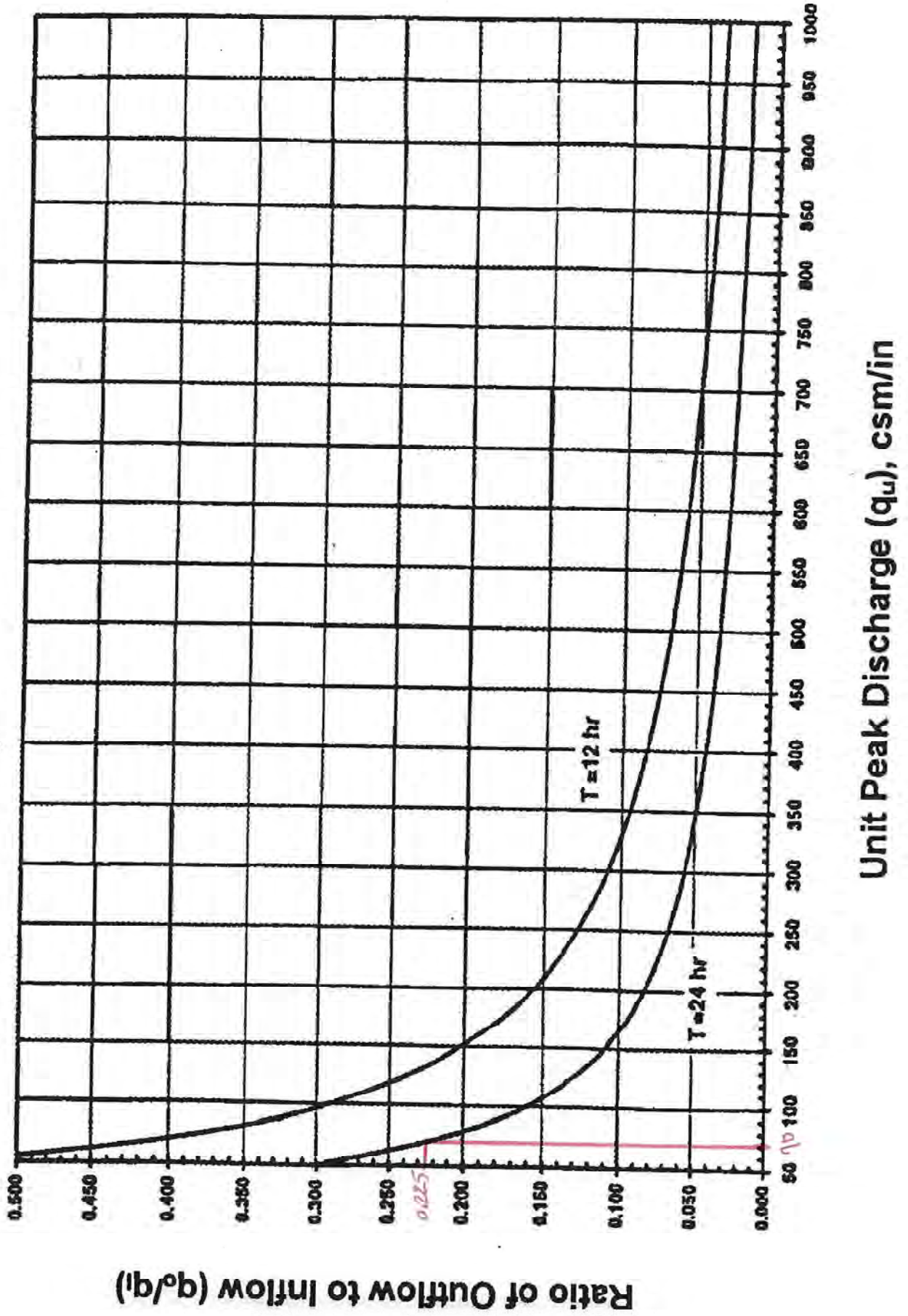

Figure 8.5 Detention Time vs. Discharge Ratios (Source: MDE, 2000)



Appendix B

General Permit No. GP-0-20-001



Department of
Environmental
Conservation

NEW YORK STATE
DEPARTMENT OF ENVIRONMENTAL CONSERVATION

SPDES GENERAL PERMIT
FOR STORMWATER DISCHARGES

From

CONSTRUCTION ACTIVITY

Permit No. GP- 0-20-001

Issued Pursuant to Article 17, Titles 7, 8 and Article 70
of the Environmental Conservation Law

Effective Date: January 29, 2020

Expiration Date: January 28, 2025

John J. Ferguson

Chief Permit Administrator



Authorized Signature

1-23-20

Date

Address: NYS DEC
Division of Environmental Permits
625 Broadway, 4th Floor
Albany, N.Y. 12233-1750

PREFACE

Pursuant to Section 402 of the Clean Water Act (“CWA”), stormwater *discharges* from certain *construction activities* are unlawful unless they are authorized by a *National Pollutant Discharge Elimination System (“NPDES”)* permit or by a state permit program. New York administers the approved State Pollutant Discharge Elimination System (SPDES) program with permits issued in accordance with the New York State Environmental Conservation Law (ECL) Article 17, Titles 7, 8 and Article 70.

An *owner or operator* of a *construction activity* that is eligible for coverage under this permit must obtain coverage prior to the *commencement of construction activity*. Activities that fit the definition of “*construction activity*”, as defined under 40 CFR 122.26(b)(14)(x), (15)(i), and (15)(ii), constitute construction of a *point source* and therefore, pursuant to ECL section 17-0505 and 17-0701, the *owner or operator* must have coverage under a SPDES permit prior to *commencing construction activity*. The *owner or operator* cannot wait until there is an actual *discharge* from the *construction site* to obtain permit coverage.

***Note: The italicized words/phrases within this permit are defined in Appendix A.**

**NEW YORK STATE DEPARTMENT OF ENVIRONMENTAL CONSERVATION
SPDES GENERAL PERMIT FOR STORMWATER DISCHARGES FROM
CONSTRUCTION ACTIVITIES**

Table of Contents

Part 1. PERMIT COVERAGE AND LIMITATIONS	1
A. Permit Application	1
B. Effluent Limitations Applicable to Discharges from Construction Activities	1
C. Post-construction Stormwater Management Practice Requirements	4
D. Maintaining Water Quality	8
E. Eligibility Under This General Permit.....	9
F. Activities Which Are Ineligible for Coverage Under This General Permit	9
Part II. PERMIT COVERAGE	12
A. How to Obtain Coverage	12
B. Notice of Intent (NOI) Submittal	13
C. Permit Authorization	13
D. General Requirements For Owners or Operators With Permit Coverage	15
E. Permit Coverage for Discharges Authorized Under GP-0-15-002.....	17
F. Change of Owner or Operator	17
Part III. STORMWATER POLLUTION PREVENTION PLAN (SWPPP).....	18
A. General SWPPP Requirements	18
B. Required SWPPP Contents	20
C. Required SWPPP Components by Project Type.....	24
Part IV. INSPECTION AND MAINTENANCE REQUIREMENTS	24
A. General Construction Site Inspection and Maintenance Requirements	24
B. Contractor Maintenance Inspection Requirements	24
C. Qualified Inspector Inspection Requirements	25
Part V. TERMINATION OF PERMIT COVERAGE	29
A. Termination of Permit Coverage	29
Part VI. REPORTING AND RETENTION RECORDS	31
A. Record Retention	31
B. Addresses	31
Part VII. STANDARD PERMIT CONDITIONS.....	31
A. Duty to Comply.....	31
B. Continuation of the Expired General Permit.....	32
C. Enforcement.....	32
D. Need to Halt or Reduce Activity Not a Defense.....	32
E. Duty to Mitigate	33
F. Duty to Provide Information.....	33
G. Other Information	33
H. Signatory Requirements.....	33
I. Property Rights	35
J. Severability.....	35

K.	Requirement to Obtain Coverage Under an Alternative Permit.....	35
L.	Proper Operation and Maintenance	36
M.	Inspection and Entry	36
N.	Permit Actions	37
O.	Definitions	37
P.	Re-Opener Clause	37
Q.	Penalties for Falsification of Forms and Reports	37
R.	Other Permits	38
APPENDIX A – Acronyms and Definitions		39
	Acronyms.....	39
	Definitions.....	40
APPENDIX B – Required SWPPP Components by Project Type		48
	Table 1.....	48
	Table 2.....	50
APPENDIX C – Watersheds Requiring Enhanced Phosphorus Removal.....		52
APPENDIX D – Watersheds with Lower Disturbance Threshold		58
APPENDIX E – 303(d) Segments Impaired by Construction Related Pollutant(s)		59
APPENDIX F – List of NYS DEC Regional Offices		65

Part 1. PERMIT COVERAGE AND LIMITATIONS

A. Permit Application

This permit authorizes stormwater *discharges* to *surface waters of the State* from the following *construction activities* identified within 40 CFR Parts 122.26(b)(14)(x), 122.26(b)(15)(i) and 122.26(b)(15)(ii), provided all of the eligibility provisions of this permit are met:

1. *Construction activities* involving soil disturbances of one (1) or more acres; including disturbances of less than one acre that are part of a *larger common plan of development or sale* that will ultimately disturb one or more acres of land; excluding *routine maintenance activity* that is performed to maintain the original line and grade, hydraulic capacity or original purpose of a facility;
2. *Construction activities* involving soil disturbances of less than one (1) acre where the Department has determined that a *SPDES* permit is required for stormwater *discharges* based on the potential for contribution to a violation of a *water quality standard* or for significant contribution of *pollutants* to *surface waters of the State*.
3. *Construction activities* located in the watershed(s) identified in Appendix D that involve soil disturbances between five thousand (5,000) square feet and one (1) acre of land.

B. Effluent Limitations Applicable to Discharges from Construction Activities

Discharges authorized by this permit must achieve, at a minimum, the effluent limitations in Part I.B.1. (a) – (f) of this permit. These limitations represent the degree of effluent reduction attainable by the application of best practicable technology currently available.

1. Erosion and Sediment Control Requirements - The *owner or operator* must select, design, install, implement and maintain control measures to *minimize* the *discharge of pollutants* and prevent a violation of the *water quality standards*. The selection, design, installation, implementation, and maintenance of these control measures must meet the non-numeric effluent limitations in Part I.B.1.(a) – (f) of this permit and be in accordance with the New York State Standards and Specifications for Erosion and Sediment Control, dated November 2016, using sound engineering judgment. Where control measures are not designed in conformance with the design criteria included in the technical standard, the *owner or operator* must include in the *Stormwater Pollution Prevention Plan* (“SWPPP”) the reason(s) for the

deviation or alternative design and provide information which demonstrates that the deviation or alternative design is *equivalent* to the technical standard.

- a. **Erosion and Sediment Controls.** Design, install and maintain effective erosion and sediment controls to *minimize the discharge of pollutants* and prevent a violation of the *water quality standards*. At a minimum, such controls must be designed, installed and maintained to:
- (i) *Minimize* soil erosion through application of runoff control and soil stabilization control measure to *minimize pollutant discharges*;
 - (ii) Control stormwater *discharges*, including both peak flowrates and total stormwater volume, to *minimize* channel and *streambank* erosion and scour in the immediate vicinity of the *discharge* points;
 - (iii) *Minimize* the amount of soil exposed during *construction activity*;
 - (iv) *Minimize* the disturbance of *steep slopes*;
 - (v) *Minimize* sediment *discharges* from the site;
 - (vi) Provide and maintain *natural buffers* around surface waters, direct stormwater to vegetated areas and maximize stormwater infiltration to reduce *pollutant discharges*, unless *infeasible*;
 - (vii) *Minimize* soil compaction. Minimizing soil compaction is not required where the intended function of a specific area of the site dictates that it be compacted;
 - (viii) Unless *infeasible*, preserve a sufficient amount of topsoil to complete soil restoration and establish a uniform, dense vegetative cover; and
 - (ix) *Minimize* dust. On areas of exposed soil, *minimize* dust through the appropriate application of water or other dust suppression techniques to control the generation of pollutants that could be discharged from the site.
- b. **Soil Stabilization.** In areas where soil disturbance activity has temporarily or permanently ceased, the application of soil stabilization measures must be initiated by the end of the next business day and completed within fourteen (14) days from the date the current soil disturbance activity ceased. For construction sites that *directly discharge* to one of the 303(d) segments

listed in Appendix E or is located in one of the watersheds listed in Appendix C, the application of soil stabilization measures must be initiated by the end of the next business day and completed within seven (7) days from the date the current soil disturbance activity ceased. See Appendix A for definition of *Temporarily Ceased*.

- c. **Dewatering.** *Discharges* from *dewatering* activities, including *discharges* from *dewatering* of trenches and excavations, must be managed by appropriate control measures.

- d. **Pollution Prevention Measures.** Design, install, implement, and maintain effective pollution prevention measures to *minimize* the *discharge* of *pollutants* and prevent a violation of the *water quality standards*. At a minimum, such measures must be designed, installed, implemented and maintained to:
 - (i) *Minimize* the *discharge* of *pollutants* from equipment and vehicle washing, wheel wash water, and other wash waters. This applies to washing operations that use clean water only. Soaps, detergents and solvents cannot be used;

 - (ii) *Minimize* the exposure of building materials, building products, construction wastes, trash, landscape materials, fertilizers, pesticides, herbicides, detergents, sanitary waste, hazardous and toxic waste, and other materials present on the site to precipitation and to stormwater. Minimization of exposure is not required in cases where the exposure to precipitation and to stormwater will not result in a *discharge* of *pollutants*, or where exposure of a specific material or product poses little risk of stormwater contamination (such as final products and materials intended for outdoor use) ; and

 - (iii) Prevent the *discharge* of *pollutants* from spills and leaks and implement chemical spill and leak prevention and response procedures.

- e. **Prohibited Discharges.** The following *discharges* are prohibited:
 - (i) Wastewater from washout of concrete;

 - (ii) Wastewater from washout and cleanout of stucco, paint, form release oils, curing compounds and other construction materials;

- (iii) Fuels, oils, or other *pollutants* used in vehicle and equipment operation and maintenance;
 - (iv) Soaps or solvents used in vehicle and equipment washing; and
 - (v) Toxic or hazardous substances from a spill or other release.
- f. Surface Outlets. When discharging from basins and impoundments, the outlets shall be designed, constructed and maintained in such a manner that sediment does not leave the basin or impoundment and that erosion at or below the outlet does not occur.

C. Post-construction Stormwater Management Practice Requirements

1. The *owner or operator of a construction activity* that requires post-construction stormwater management practices pursuant to Part III.C. of this permit must select, design, install, and maintain the practices to meet the *performance criteria* in the New York State Stormwater Management Design Manual (“Design Manual”), dated January 2015, using sound engineering judgment. Where post-construction stormwater management practices (“SMPs”) are not designed in conformance with the *performance criteria* in the Design Manual, the *owner or operator* must include in the SWPPP the reason(s) for the deviation or alternative design and provide information which demonstrates that the deviation or alternative design is *equivalent* to the technical standard.
2. The *owner or operator of a construction activity* that requires post-construction stormwater management practices pursuant to Part III.C. of this permit must design the practices to meet the applicable *sizing criteria* in Part I.C.2.a., b., c. or d. of this permit.

a. Sizing Criteria for New Development

- (i) Runoff Reduction Volume (“RRv”): Reduce the total Water Quality Volume (“WQv”) by application of RR techniques and standard SMPs with RRv capacity. The total WQv shall be calculated in accordance with the criteria in Section 4.2 of the Design Manual.
- (ii) Minimum RRv and Treatment of Remaining Total WQv: Construction activities that cannot meet the criteria in Part I.C.2.a.(i) of this permit due to site limitations shall direct runoff from all newly constructed impervious areas to a RR technique or standard SMP with RRv capacity unless infeasible. The specific site limitations that prevent the reduction of 100% of the WQv shall be documented in the SWPPP.

For each impervious area that is not directed to a RR technique or standard SMP with RRv capacity, the SWPPP must include documentation which demonstrates that all options were considered and for each option explains why it is considered infeasible.

In no case shall the runoff reduction achieved from the newly constructed impervious areas be less than the Minimum RRv as calculated using the criteria in Section 4.3 of the Design Manual.

The remaining portion of the total WQv that cannot be reduced shall be treated by application of standard SMPs.

- (iii) Channel Protection Volume (“Cpv”): Provide 24 hour extended detention of the post-developed 1-year, 24-hour storm event; remaining after runoff reduction. The Cpv requirement does not apply when:
 - (1) Reduction of the entire Cpv is achieved by application of runoff reduction techniques or infiltration systems, or
 - (2) The site discharges directly to tidal waters, or fifth order or larger streams.

- (iv) *Overbank* Flood Control Criteria (“Qp”): Requires storage to attenuate the post-development 10-year, 24-hour peak discharge rate (Qp) to predevelopment rates. The Qp requirement does not apply when:
 - (1) the site discharges directly to tidal waters or fifth order or larger streams, or
 - (2) A downstream analysis reveals that *overbank* control is not required.

- (v) Extreme Flood Control Criteria (“Qf”): Requires storage to attenuate the post-development 100-year, 24-hour peak discharge rate (Qf) to predevelopment rates. The Qf requirement does not apply when:
 - (1) the site discharges directly to tidal waters or fifth order or larger streams, or
 - (2) A downstream analysis reveals that *overbank* control is not required.

b. Sizing Criteria for New Development in Enhanced Phosphorus Removal Watershed

- (i) Runoff Reduction Volume (RRv): Reduce the total Water Quality Volume (WQv) by application of RR techniques and standard SMPs with RRv capacity. The total WQv is the runoff volume from the 1-year, 24 hour design storm over the post-developed watershed and shall be

calculated in accordance with the criteria in Section 10.3 of the Design Manual.

- (ii) Minimum RRv and Treatment of Remaining Total WQv: *Construction activities* that cannot meet the criteria in Part I.C.2.b.(i) of this permit due to *site limitations* shall direct runoff from all newly constructed *impervious areas* to a RR technique or standard SMP with RRv capacity unless *infeasible*. The specific *site limitations* that prevent the reduction of 100% of the WQv shall be documented in the SWPPP. For each *impervious area* that is not directed to a RR technique or standard SMP with RRv capacity, the SWPPP must include documentation which demonstrates that all options were considered and for each option explains why it is considered *infeasible*.

In no case shall the runoff reduction achieved from the newly constructed *impervious areas* be less than the Minimum RRv as calculated using the criteria in Section 10.3 of the Design Manual. The remaining portion of the total WQv that cannot be reduced shall be treated by application of standard SMPs.

- (iii) Channel Protection Volume (Cpv): Provide 24 hour extended detention of the post-developed 1-year, 24-hour storm event; remaining after runoff reduction. The Cpv requirement does not apply when:
 - (1) Reduction of the entire Cpv is achieved by application of runoff reduction techniques or infiltration systems, or
 - (2) The site *discharges* directly to tidal waters, or fifth order or larger streams.
- (iv) *Overbank* Flood Control Criteria (Qp): Requires storage to attenuate the post-development 10-year, 24-hour peak *discharge* rate (Qp) to predevelopment rates. The Qp requirement does not apply when:
 - (1) the site *discharges* directly to tidal waters or fifth order or larger streams, or
 - (2) A downstream analysis reveals that *overbank* control is not required.
- (v) Extreme Flood Control Criteria (Qf): Requires storage to attenuate the post-development 100-year, 24-hour peak *discharge* rate (Qf) to predevelopment rates. The Qf requirement does not apply when:
 - (1) the site *discharges* directly to tidal waters or fifth order or larger streams, or
 - (2) A downstream analysis reveals that *overbank* control is not required.

c. Sizing Criteria for Redevelopment Activity

- (i) Water Quality Volume (WQv): The WQv treatment objective for *redevelopment activity* shall be addressed by one of the following options. *Redevelopment activities* located in an Enhanced Phosphorus Removal Watershed (see Part III.B.3. and Appendix C of this permit) shall calculate the WQv in accordance with Section 10.3 of the Design Manual. All other *redevelopment activities* shall calculate the WQv in accordance with Section 4.2 of the Design Manual.
- (1) Reduce the existing *impervious cover* by a minimum of 25% of the total disturbed, *impervious area*. The Soil Restoration criteria in Section 5.1.6 of the Design Manual must be applied to all newly created pervious areas, or
 - (2) Capture and treat a minimum of 25% of the WQv from the disturbed, *impervious area* by the application of standard SMPs; or reduce 25% of the WQv from the disturbed, *impervious area* by the application of RR techniques or standard SMPs with RRv capacity., or
 - (3) Capture and treat a minimum of 75% of the WQv from the disturbed, *impervious area* as well as any additional runoff from tributary areas by application of the alternative practices discussed in Sections 9.3 and 9.4 of the Design Manual., or
 - (4) Application of a combination of 1, 2 and 3 above that provide a weighted average of at least two of the above methods. Application of this method shall be in accordance with the criteria in Section 9.2.1(B) (IV) of the Design Manual.

If there is an existing post-construction stormwater management practice located on the site that captures and treats runoff from the *impervious area* that is being disturbed, the WQv treatment option selected must, at a minimum, provide treatment equal to the treatment that was being provided by the existing practice(s) if that treatment is greater than the treatment required by options 1 – 4 above.

- (ii) Channel Protection Volume (Cpv): Not required if there are no changes to hydrology that increase the *discharge* rate from the project site.
- (iii) *Overbank* Flood Control Criteria (Qp): Not required if there are no changes to hydrology that increase the *discharge* rate from the project site.
- (iv) Extreme Flood Control Criteria (Qf): Not required if there are no changes to hydrology that increase the *discharge* rate from the project site

d. Sizing Criteria for Combination of Redevelopment Activity and New Development

Construction projects that include both New Development and Redevelopment Activity shall provide post-construction stormwater management controls that meet the sizing criteria calculated as an aggregate of the Sizing Criteria in Part I.C.2.a. or b. of this permit for the New Development portion of the project and Part I.C.2.c of this permit for Redevelopment Activity portion of the project.

D. Maintaining Water Quality

The Department expects that compliance with the conditions of this permit will control *discharges* necessary to meet applicable *water quality standards*. It shall be a violation of the *ECL* for any discharge to either cause or contribute to a violation of *water quality standards* as contained in Parts 700 through 705 of Title 6 of the Official Compilation of Codes, Rules and Regulations of the State of New York, such as:

1. There shall be no increase in turbidity that will cause a substantial visible contrast to natural conditions;
2. There shall be no increase in suspended, colloidal or settleable solids that will cause deposition or impair the waters for their best usages; and
3. There shall be no residue from oil and floating substances, nor visible oil film, nor globules of grease.

If there is evidence indicating that the stormwater *discharges* authorized by this permit are causing, have the reasonable potential to cause, or are contributing to a violation of the *water quality standards*; the *owner or operator* must take appropriate corrective action in accordance with Part IV.C.5. of this general permit and document in accordance with Part IV.C.4. of this general permit. To address the *water quality standard* violation the *owner or operator* may need to provide additional information, include and implement appropriate controls in the SWPPP to correct the problem, or obtain an individual SPDES permit.

If there is evidence indicating that despite compliance with the terms and conditions of this general permit it is demonstrated that the stormwater *discharges* authorized by this permit are causing or contributing to a violation of *water quality standards*, or if the Department determines that a modification of the permit is necessary to prevent a violation of *water quality standards*, the authorized *discharges* will no longer be eligible for coverage under this permit. The Department may require the *owner or operator* to obtain an individual SPDES permit to continue discharging.

E. Eligibility Under This General Permit

1. This permit may authorize all *discharges* of stormwater from *construction activity to surface waters of the State* and *groundwaters* except for ineligible *discharges* identified under subparagraph F. of this Part.
2. Except for non-stormwater *discharges* explicitly listed in the next paragraph, this permit only authorizes stormwater *discharges*; including stormwater runoff, snowmelt runoff, and surface runoff and drainage, from *construction activities*.
3. Notwithstanding paragraphs E.1 and E.2 above, the following non-stormwater discharges are authorized by this permit: those listed in 6 NYCRR 750-1.2(a)(29)(vi), with the following exception: “Discharges from firefighting activities are authorized only when the firefighting activities are emergencies/unplanned”; waters to which other components have not been added that are used to control dust in accordance with the SWPPP; and uncontaminated *discharges* from *construction site* de-watering operations. All non-stormwater discharges must be identified in the SWPPP. Under all circumstances, the *owner or operator* must still comply with *water quality standards* in Part I.D of this permit.
4. The *owner or operator* must maintain permit eligibility to *discharge* under this permit. Any *discharges* that are not compliant with the eligibility conditions of this permit are not authorized by the permit and the *owner or operator* must either apply for a separate permit to cover those ineligible *discharges* or take steps necessary to make the *discharge* eligible for coverage.

F. Activities Which Are Ineligible for Coverage Under This General Permit

All of the following are **not** authorized by this permit:

1. *Discharges after construction activities* have been completed and the site has undergone *final stabilization*;
2. *Discharges* that are mixed with sources of non-stormwater other than those expressly authorized under subsection E.3. of this Part and identified in the SWPPP required by this permit;
3. *Discharges* that are required to obtain an individual SPDES permit or another SPDES general permit pursuant to Part VII.K. of this permit;
4. *Construction activities or discharges from construction activities* that may adversely affect an *endangered or threatened species* unless the *owner or*

operator has obtained a permit issued pursuant to 6 NYCRR Part 182 for the project or the Department has issued a letter of non-jurisdiction for the project. All documentation necessary to demonstrate eligibility shall be maintained on site in accordance with Part II.D.2 of this permit;

5. *Discharges* which either cause or contribute to a violation of *water quality standards* adopted pursuant to the *ECL* and its accompanying regulations;
6. *Construction activities* for residential, commercial and institutional projects:
 - a. Where the *discharges* from the *construction activities* are tributary to waters of the state classified as AA or AA-s; and
 - b. Which are undertaken on land with no existing *impervious cover*; and
 - c. Which disturb one (1) or more acres of land designated on the current United States Department of Agriculture (“USDA”) Soil Survey as Soil Slope Phase “D”, (provided the map unit name is inclusive of slopes greater than 25%), or Soil Slope Phase “E” or “F” (regardless of the map unit name), or a combination of the three designations.
7. *Construction activities* for linear transportation projects and linear utility projects:
 - a. Where the *discharges* from the *construction activities* are tributary to waters of the state classified as AA or AA-s; and
 - b. Which are undertaken on land with no existing *impervious cover*; and
 - c. Which disturb two (2) or more acres of land designated on the current USDA Soil Survey as Soil Slope Phase “D” (provided the map unit name is inclusive of slopes greater than 25%), or Soil Slope Phase “E” or “F” (regardless of the map unit name), or a combination of the three designations.

8. *Construction activities* that have the potential to affect an *historic property*, unless there is documentation that such impacts have been resolved. The following documentation necessary to demonstrate eligibility with this requirement shall be maintained on site in accordance with Part II.D.2 of this permit and made available to the Department in accordance with Part VII.F of this permit:
- a. Documentation that the *construction activity* is not within an archeologically sensitive area indicated on the sensitivity map, and that the *construction activity* is not located on or immediately adjacent to a property listed or determined to be eligible for listing on the National or State Registers of Historic Places, and that there is no new permanent building on the *construction site* within the following distances from a building, structure, or object that is more than 50 years old, or if there is such a new permanent building on the *construction site* within those parameters that NYS Office of Parks, Recreation and Historic Preservation (OPRHP), a Historic Preservation Commission of a Certified Local Government, or a qualified preservation professional has determined that the building, structure, or object more than 50 years old is not historically/archeologically significant.
 - 1-5 acres of disturbance - 20 feet
 - 5-20 acres of disturbance - 50 feet
 - 20+ acres of disturbance - 100 feet, or
 - b. DEC consultation form sent to OPRHP, and copied to the NYS DEC Agency Historic Preservation Officer (APO), and
 - (i) the State Environmental Quality Review (SEQR) Environmental Assessment Form (EAF) with a negative declaration or the Findings Statement, with documentation of OPRHP's agreement with the resolution; or
 - (ii) documentation from OPRHP that the *construction activity* will result in No Impact; or
 - (iii) documentation from OPRHP providing a determination of No Adverse Impact; or
 - (iv) a Letter of Resolution signed by the owner/operator, OPRHP and the DEC APO which allows for this *construction activity* to be eligible for coverage under the general permit in terms of the State Historic Preservation Act (SHPA); or
 - c. Documentation of satisfactory compliance with Section 106 of the National Historic Preservation Act for a coterminous project area:

- (i) No Affect
- (ii) No Adverse Affect
- (iii) Executed Memorandum of Agreement, or

d. Documentation that:

- (i) SHPA Section 14.09 has been completed by NYS DEC or another state agency.
9. *Discharges from construction activities* that are subject to an existing SPDES individual or general permit where a SPDES permit for *construction activity* has been terminated or denied; or where the *owner or operator* has failed to renew an expired individual permit.

Part II. PERMIT COVERAGE

A. How to Obtain Coverage

1. An *owner or operator* of a *construction activity* that is not subject to the requirements of a regulated, traditional land use control MS4 must first prepare a SWPPP in accordance with all applicable requirements of this permit and then submit a completed Notice of Intent (NOI) to the Department to be authorized to discharge under this permit.
2. An *owner or operator* of a *construction activity* that is subject to the requirements of a *regulated, traditional land use control MS4* must first prepare a SWPPP in accordance with all applicable requirements of this permit and then have the SWPPP reviewed and accepted by the *regulated, traditional land use control MS4* prior to submitting the NOI to the Department. The *owner or operator* shall have the “MS4 SWPPP Acceptance” form signed in accordance with Part VII.H., and then submit that form along with a completed NOI to the Department.
3. The requirement for an *owner or operator* to have its SWPPP reviewed and accepted by the *regulated, traditional land use control MS4* prior to submitting the NOI to the Department does not apply to an *owner or operator* that is obtaining permit coverage in accordance with the requirements in Part II.F. (Change of Owner or Operator) or where the *owner or operator* of the *construction activity* is the *regulated, traditional land use control MS4* . This exemption does not apply to *construction activities* subject to the New York City Administrative Code.

B. Notice of Intent (NOI) Submittal

1. Prior to December 21, 2020, an owner or operator shall use either the electronic (eNOI) or paper version of the NOI that the Department prepared. Both versions of the NOI are located on the Department's website (<http://www.dec.ny.gov/>). The paper version of the NOI shall be signed in accordance with Part VII.H. of this permit and submitted to the following address:

**NOTICE OF INTENT
NYS DEC, Bureau of Water Permits
625 Broadway, 4th Floor
Albany, New York 12233-3505**

2. Beginning December 21, 2020 and in accordance with EPA's 2015 NPDES Electronic Reporting Rule (40 CFR Part 127), the *owner or operator* must submit the NOI electronically using the *Department's* online NOI.
3. The *owner or operator* shall have the SWPPP preparer sign the "SWPPP Preparer Certification" statement on the NOI prior to submitting the form to the Department.
4. As of the date the NOI is submitted to the Department, the *owner or operator* shall make the NOI and SWPPP available for review and copying in accordance with the requirements in Part VII.F. of this permit.

C. Permit Authorization

1. An *owner or operator* shall not *commence construction activity* until their authorization to *discharge* under this permit goes into effect.
2. Authorization to *discharge* under this permit will be effective when the *owner or operator* has satisfied all of the following criteria:
 - a. project review pursuant to the State Environmental Quality Review Act ("SEQRA") have been satisfied, when SEQRA is applicable. See the Department's website (<http://www.dec.ny.gov/>) for more information,
 - b. where required, all necessary Department permits subject to the *Uniform Procedures Act ("UPA")* (see 6 NYCRR Part 621), or the equivalent from another New York State agency, have been obtained, unless otherwise notified by the Department pursuant to 6 NYCRR 621.3(a)(4). *Owners or operators of construction activities* that are required to obtain *UPA* permits

must submit a preliminary SWPPP to the appropriate DEC Permit Administrator at the Regional Office listed in Appendix F at the time all other necessary *UPA* permit applications are submitted. The preliminary SWPPP must include sufficient information to demonstrate that the *construction activity* qualifies for authorization under this permit,

- c. the final SWPPP has been prepared, and
 - d. a complete NOI has been submitted to the Department in accordance with the requirements of this permit.
3. An *owner or operator* that has satisfied the requirements of Part II.C.2 above will be authorized to *discharge* stormwater from their *construction activity* in accordance with the following schedule:
- a. For *construction activities* that are not subject to the requirements of a *regulated, traditional land use control MS4*:
 - (i) Five (5) business days from the date the Department receives a complete electronic version of the NOI (eNOI) for *construction activities* with a SWPPP that has been prepared in conformance with the design criteria in the technical standard referenced in Part III.B.1 and the *performance criteria* in the technical standard referenced in Parts III.B., 2 or 3, for *construction activities* that require post-construction stormwater management practices pursuant to Part III.C.; or
 - (ii) Sixty (60) business days from the date the Department receives a complete NOI (electronic or paper version) for *construction activities* with a SWPPP that has not been prepared in conformance with the design criteria in technical standard referenced in Part III.B.1. or, for *construction activities* that require post-construction stormwater management practices pursuant to Part III.C., the *performance criteria* in the technical standard referenced in Parts III.B., 2 or 3, or;
 - (iii) Ten (10) business days from the date the Department receives a complete paper version of the NOI for *construction activities* with a SWPPP that has been prepared in conformance with the design criteria in the technical standard referenced in Part III.B.1 and the *performance criteria* in the technical standard referenced in Parts III.B., 2 or 3, for *construction activities* that require post-construction stormwater management practices pursuant to Part III.C.

- b. For *construction activities* that are subject to the requirements of a *regulated, traditional land use control MS4*:
 - (i) Five (5) business days from the date the Department receives both a complete electronic version of the NOI (eNOI) and signed “MS4 SWPPP Acceptance” form, or
 - (ii) Ten (10) business days from the date the Department receives both a complete paper version of the NOI and signed “MS4 SWPPP Acceptance” form.
4. Coverage under this permit authorizes stormwater *discharges* from only those areas of disturbance that are identified in the NOI. If an *owner or operator* wishes to have stormwater *discharges* from future or additional areas of disturbance authorized, they must submit a new NOI that addresses that phase of the development, unless otherwise notified by the Department. The *owner or operator* shall not *commence construction activity* on the future or additional areas until their authorization to *discharge* under this permit goes into effect in accordance with Part II.C. of this permit.

D. General Requirements For Owners or Operators With Permit Coverage

1. The *owner or operator* shall ensure that the provisions of the SWPPP are implemented from the *commencement of construction activity* until all areas of disturbance have achieved *final stabilization* and the Notice of Termination (“NOT”) has been submitted to the Department in accordance with Part V. of this permit. This includes any changes made to the SWPPP pursuant to Part III.A.4. of this permit.
2. The *owner or operator* shall maintain a copy of the General Permit (GP-0-20-001), NOI, *NOI Acknowledgment Letter*, SWPPP, MS4 SWPPP Acceptance form, inspection reports, responsible contractor’s or subcontractor’s certification statement (see Part III.A.6.), and all documentation necessary to demonstrate eligibility with this permit at the *construction site* until all disturbed areas have achieved *final stabilization* and the NOT has been submitted to the Department. The documents must be maintained in a secure location, such as a job trailer, on-site construction office, or mailbox with lock. The secure location must be accessible during normal business hours to an individual performing a compliance inspection.
3. The *owner or operator of a construction activity* shall not disturb greater than five (5) acres of soil at any one time without prior written authorization from the Department or, in areas under the jurisdiction of a *regulated, traditional land*

- use control MS4, the regulated, traditional land use control MS4 (provided the regulated, traditional land use control MS4 is not the owner or operator of the construction activity). At a minimum, the owner or operator must comply with the following requirements in order to be authorized to disturb greater than five (5) acres of soil at any one time:*
- a. The *owner or operator* shall have a *qualified inspector* conduct **at least two** (2) site inspections in accordance with Part IV.C. of this permit every seven (7) calendar days, for as long as greater than five (5) acres of soil remain disturbed. The two (2) inspections shall be separated by a minimum of two (2) full calendar days.
 - b. In areas where soil disturbance activity has temporarily or permanently ceased, the application of soil stabilization measures must be initiated by the end of the next business day and completed within seven (7) days from the date the current soil disturbance activity ceased. The soil stabilization measures selected shall be in conformance with the technical standard, New York State Standards and Specifications for Erosion and Sediment Control, dated November 2016.
 - c. The *owner or operator* shall prepare a phasing plan that defines maximum disturbed area per phase and shows required cuts and fills.
 - d. The *owner or operator* shall install any additional site-specific practices needed to protect water quality.
 - e. The *owner or operator* shall include the requirements above in their SWPPP.
4. In accordance with statute, regulations, and the terms and conditions of this permit, the Department may suspend or revoke an *owner's or operator's* coverage under this permit at any time if the Department determines that the SWPPP does not meet the permit requirements or consistent with Part VII.K..
 5. Upon a finding of significant non-compliance with the practices described in the SWPPP or violation of this permit, the Department may order an immediate stop to all activity at the site until the non-compliance is remedied. The stop work order shall be in writing, describe the non-compliance in detail, and be sent to the *owner or operator*.
 6. For *construction activities* that are subject to the requirements of a *regulated, traditional land use control MS4*, the *owner or operator* shall notify the

regulated, traditional land use control MS4 in writing of any planned amendments or modifications to the post-construction stormwater management practice component of the SWPPP required by Part III.A. 4. and 5. of this permit. Unless otherwise notified by the *regulated, traditional land use control MS4*, the *owner or operator* shall have the SWPPP amendments or modifications reviewed and accepted by the *regulated, traditional land use control MS4* prior to commencing construction of the post-construction stormwater management practice.

E. Permit Coverage for Discharges Authorized Under GP-0-15-002

1. Upon renewal of SPDES General Permit for Stormwater Discharges from *Construction Activity* (Permit No. GP-0-15-002), an *owner or operator* of a *construction activity* with coverage under GP-0-15-002, as of the effective date of GP- 0-20-001, shall be authorized to *discharge* in accordance with GP- 0-20-001, unless otherwise notified by the Department.

An *owner or operator* may continue to implement the technical/design components of the post-construction stormwater management controls provided that such design was done in conformance with the technical standards in place at the time of initial project authorization. However, they must comply with the other, non-design provisions of GP-0-20-001.

F. Change of Owner or Operator

1. When property ownership changes or when there is a change in operational control over the construction plans and specifications, the original *owner or operator* must notify the new *owner or operator*, in writing, of the requirement to obtain permit coverage by submitting a NOI with the Department. For *construction activities* subject to the requirements of a *regulated, traditional land use control MS4*, the original *owner or operator* must also notify the MS4, in writing, of the change in ownership at least 30 calendar days prior to the change in ownership.
2. Once the new *owner or operator* obtains permit coverage, the original *owner or operator* shall then submit a completed NOT with the name and permit identification number of the new *owner or operator* to the Department at the address in Part II.B.1. of this permit. If the original *owner or operator* maintains ownership of a portion of the *construction activity* and will disturb soil, they must maintain their coverage under the permit.
3. Permit coverage for the new *owner or operator* will be effective as of the date the Department receives a complete NOI, provided the original *owner or*

operator was not subject to a sixty (60) business day authorization period that has not expired as of the date the Department receives the NOI from the new *owner or operator*.

Part III. STORMWATER POLLUTION PREVENTION PLAN (SWPPP)

A. General SWPPP Requirements

1. A SWPPP shall be prepared and implemented by the *owner or operator* of each *construction activity* covered by this permit. The SWPPP must document the selection, design, installation, implementation and maintenance of the control measures and practices that will be used to meet the effluent limitations in Part I.B. of this permit and where applicable, the post-construction stormwater management practice requirements in Part I.C. of this permit. The SWPPP shall be prepared prior to the submittal of the NOI. The NOI shall be submitted to the Department prior to the *commencement of construction activity*. A copy of the completed, final NOI shall be included in the SWPPP.
2. The SWPPP shall describe the erosion and sediment control practices and where required, post-construction stormwater management practices that will be used and/or constructed to reduce the *pollutants* in stormwater *discharges* and to assure compliance with the terms and conditions of this permit. In addition, the SWPPP shall identify potential sources of pollution which may reasonably be expected to affect the quality of stormwater *discharges*.
3. All SWPPPs that require the post-construction stormwater management practice component shall be prepared by a *qualified professional* that is knowledgeable in the principles and practices of stormwater management and treatment.
4. The *owner or operator* must keep the SWPPP current so that it at all times accurately documents the erosion and sediment controls practices that are being used or will be used during construction, and all post-construction stormwater management practices that will be constructed on the site. At a minimum, the *owner or operator* shall amend the SWPPP, including construction drawings:
 - a. whenever the current provisions prove to be ineffective in minimizing *pollutants* in stormwater *discharges* from the site;

- b. whenever there is a change in design, construction, or operation at the *construction site* that has or could have an effect on the *discharge* of *pollutants*;
 - c. to address issues or deficiencies identified during an inspection by the *qualified inspector*, the Department or other regulatory authority; and
 - d. to document the final construction conditions.
5. The Department may notify the *owner or operator* at any time that the SWPPP does not meet one or more of the minimum requirements of this permit. The notification shall be in writing and identify the provisions of the SWPPP that require modification. Within fourteen (14) calendar days of such notification, or as otherwise indicated by the Department, the *owner or operator* shall make the required changes to the SWPPP and submit written notification to the Department that the changes have been made. If the *owner or operator* does not respond to the Department's comments in the specified time frame, the Department may suspend the *owner's or operator's* coverage under this permit or require the *owner or operator* to obtain coverage under an individual SPDES permit in accordance with Part II.D.4. of this permit.
6. Prior to the *commencement of construction activity*, the *owner or operator* must identify the contractor(s) and subcontractor(s) that will be responsible for installing, constructing, repairing, replacing, inspecting and maintaining the erosion and sediment control practices included in the SWPPP; and the contractor(s) and subcontractor(s) that will be responsible for constructing the post-construction stormwater management practices included in the SWPPP. The *owner or operator* shall have each of the contractors and subcontractors identify at least one person from their company that will be responsible for implementation of the SWPPP. This person shall be known as the *trained contractor*. The *owner or operator* shall ensure that at least one *trained contractor* is on site on a daily basis when soil disturbance activities are being performed.

The *owner or operator* shall have each of the contractors and subcontractors identified above sign a copy of the following certification statement below before they commence any *construction activity*:

"I hereby certify under penalty of law that I understand and agree to comply with the terms and conditions of the SWPPP and agree to implement any corrective actions identified by the *qualified inspector* during a site inspection. I also understand that the *owner or operator* must comply with

the terms and conditions of the most current version of the New York State Pollutant Discharge Elimination System ("SPDES") general permit for stormwater *discharges* from *construction activities* and that it is unlawful for any person to cause or contribute to a violation of *water quality standards*. Furthermore, I am aware that there are significant penalties for submitting false information, that I do not believe to be true, including the possibility of fine and imprisonment for knowing violations"

In addition to providing the certification statement above, the certification page must also identify the specific elements of the SWPPP that each contractor and subcontractor will be responsible for and include the name and title of the person providing the signature; the name and title of the *trained contractor* responsible for SWPPP implementation; the name, address and telephone number of the contracting firm; the address (or other identifying description) of the site; and the date the certification statement is signed. The *owner or operator* shall attach the certification statement(s) to the copy of the SWPPP that is maintained at the *construction site*. If new or additional contractors are hired to implement measures identified in the SWPPP after construction has commenced, they must also sign the certification statement and provide the information listed above.

7. For projects where the Department requests a copy of the SWPPP or inspection reports, the *owner or operator* shall submit the documents in both electronic (PDF only) and paper format within five (5) business days, unless otherwise notified by the Department.

B. Required SWPPP Contents

1. Erosion and sediment control component - All SWPPPs prepared pursuant to this permit shall include erosion and sediment control practices designed in conformance with the technical standard, New York State Standards and Specifications for Erosion and Sediment Control, dated November 2016. Where erosion and sediment control practices are not designed in conformance with the design criteria included in the technical standard, the *owner or operator* must demonstrate *equivalence* to the technical standard. At a minimum, the erosion and sediment control component of the SWPPP shall include the following:
 - a. Background information about the scope of the project, including the location, type and size of project

- b. A site map/construction drawing(s) for the project, including a general location map. At a minimum, the site map shall show the total site area; all improvements; areas of disturbance; areas that will not be disturbed; existing vegetation; on-site and adjacent off-site surface water(s); floodplain/floodway boundaries; wetlands and drainage patterns that could be affected by the *construction activity*; existing and final contours ; locations of different soil types with boundaries; material, waste, borrow or equipment storage areas located on adjacent properties; and location(s) of the stormwater *discharge(s)*;
- c. A description of the soil(s) present at the site, including an identification of the Hydrologic Soil Group (HSG);
- d. A construction phasing plan and sequence of operations describing the intended order of *construction activities*, including clearing and grubbing, excavation and grading, utility and infrastructure installation and any other activity at the site that results in soil disturbance;
- e. A description of the minimum erosion and sediment control practices to be installed or implemented for each *construction activity* that will result in soil disturbance. Include a schedule that identifies the timing of initial placement or implementation of each erosion and sediment control practice and the minimum time frames that each practice should remain in place or be implemented;
- f. A temporary and permanent soil stabilization plan that meets the requirements of this general permit and the technical standard, New York State Standards and Specifications for Erosion and Sediment Control, dated November 2016, for each stage of the project, including initial land clearing and grubbing to project completion and achievement of *final stabilization*;
- g. A site map/construction drawing(s) showing the specific location(s), size(s), and length(s) of each erosion and sediment control practice;
- h. The dimensions, material specifications, installation details, and operation and maintenance requirements for all erosion and sediment control practices. Include the location and sizing of any temporary sediment basins and structural practices that will be used to divert flows from exposed soils;
- i. A maintenance inspection schedule for the contractor(s) identified in Part III.A.6. of this permit, to ensure continuous and effective operation of the erosion and sediment control practices. The maintenance inspection

schedule shall be in accordance with the requirements in the technical standard, New York State Standards and Specifications for Erosion and Sediment Control, dated November 2016;

- j. A description of the pollution prevention measures that will be used to control litter, construction chemicals and construction debris from becoming a *pollutant* source in the stormwater *discharges*;
 - k. A description and location of any stormwater *discharges* associated with industrial activity other than construction at the site, including, but not limited to, stormwater *discharges* from asphalt plants and concrete plants located on the *construction site*; and
 - l. Identification of any elements of the design that are not in conformance with the design criteria in the technical standard, New York State Standards and Specifications for Erosion and Sediment Control, dated November 2016. Include the reason for the deviation or alternative design and provide information which demonstrates that the deviation or alternative design is *equivalent* to the technical standard.
2. Post-construction stormwater management practice component – The *owner or operator* of any construction project identified in Table 2 of Appendix B as needing post-construction stormwater management practices shall prepare a SWPPP that includes practices designed in conformance with the applicable *sizing criteria* in Part I.C.2.a., c. or d. of this permit and the *performance criteria* in the technical standard, New York State Stormwater Management Design Manual dated January 2015

Where post-construction stormwater management practices are not designed in conformance with the *performance criteria* in the technical standard, the *owner or operator* must include in the SWPPP the reason(s) for the deviation or alternative design and provide information which demonstrates that the deviation or alternative design is *equivalent* to the technical standard.

The post-construction stormwater management practice component of the SWPPP shall include the following:

- a. Identification of all post-construction stormwater management practices to be constructed as part of the project. Include the dimensions, material specifications and installation details for each post-construction stormwater management practice;

- b. A site map/construction drawing(s) showing the specific location and size of each post-construction stormwater management practice;
- c. A Stormwater Modeling and Analysis Report that includes:
 - (i) Map(s) showing pre-development conditions, including watershed/subcatchments boundaries, flow paths/routing, and design points;
 - (ii) Map(s) showing post-development conditions, including watershed/subcatchments boundaries, flow paths/routing, design points and post-construction stormwater management practices;
 - (iii) Results of stormwater modeling (i.e. hydrology and hydraulic analysis) for the required storm events. Include supporting calculations (model runs), methodology, and a summary table that compares pre and post-development runoff rates and volumes for the different storm events;
 - (iv) Summary table, with supporting calculations, which demonstrates that each post-construction stormwater management practice has been designed in conformance with the *sizing criteria* included in the Design Manual;
 - (v) Identification of any *sizing criteria* that is not required based on the requirements included in Part I.C. of this permit; and
 - (vi) Identification of any elements of the design that are not in conformance with the *performance criteria* in the Design Manual. Include the reason(s) for the deviation or alternative design and provide information which demonstrates that the deviation or alternative design is *equivalent* to the Design Manual;
- d. Soil testing results and locations (test pits, borings);
- e. Infiltration test results, when required; and
- f. An operations and maintenance plan that includes inspection and maintenance schedules and actions to ensure continuous and effective operation of each post-construction stormwater management practice. The plan shall identify the entity that will be responsible for the long term operation and maintenance of each practice.

3. Enhanced Phosphorus Removal Standards - All construction projects identified in Table 2 of Appendix B that are located in the watersheds identified in Appendix C shall prepare a SWPPP that includes post-construction stormwater management practices designed in conformance with the applicable *sizing criteria* in Part I.C.2. b., c. or d. of this permit and the *performance criteria*, Enhanced Phosphorus Removal Standards included in the Design Manual. At a minimum, the post-construction stormwater management practice component of the SWPPP shall include items 2.a - 2.f. above.

C. Required SWPPP Components by Project Type

Unless otherwise notified by the Department, *owners or operators of construction activities* identified in Table 1 of Appendix B are required to prepare a SWPPP that only includes erosion and sediment control practices designed in conformance with Part III.B.1 of this permit. *Owners or operators of the construction activities* identified in Table 2 of Appendix B shall prepare a SWPPP that also includes post-construction stormwater management practices designed in conformance with Part III.B.2 or 3 of this permit.

Part IV. INSPECTION AND MAINTENANCE REQUIREMENTS

A. General Construction Site Inspection and Maintenance Requirements

1. The *owner or operator* must ensure that all erosion and sediment control practices (including pollution prevention measures) and all post-construction stormwater management practices identified in the SWPPP are inspected and maintained in accordance with Part IV.B. and C. of this permit.
2. The terms of this permit shall not be construed to prohibit the State of New York from exercising any authority pursuant to the ECL, common law or federal law, or prohibit New York State from taking any measures, whether civil or criminal, to prevent violations of the laws of the State of New York or protect the public health and safety and/or the environment.

B. Contractor Maintenance Inspection Requirements

1. The *owner or operator* of each *construction activity* identified in Tables 1 and 2 of Appendix B shall have a *trained contractor* inspect the erosion and sediment control practices and pollution prevention measures being implemented within the active work area daily to ensure that they are being maintained in effective operating condition at all times. If deficiencies are identified, the contractor shall

begin implementing corrective actions within one business day and shall complete the corrective actions in a reasonable time frame.

2. For construction sites where soil disturbance activities have been temporarily suspended (e.g. winter shutdown) and *temporary stabilization* measures have been applied to all disturbed areas, the *trained contractor* can stop conducting the maintenance inspections. The *trained contractor* shall begin conducting the maintenance inspections in accordance with Part IV.B.1. of this permit as soon as soil disturbance activities resume.
3. For construction sites where soil disturbance activities have been shut down with partial project completion, the *trained contractor* can stop conducting the maintenance inspections if all areas disturbed as of the project shutdown date have achieved *final stabilization* and all post-construction stormwater management practices required for the completed portion of the project have been constructed in conformance with the SWPPP and are operational.

C. Qualified Inspector Inspection Requirements

The *owner or operator* shall have a *qualified inspector* conduct site inspections in conformance with the following requirements:

[Note: The *trained contractor* identified in Part III.A.6. and IV.B. of this permit **cannot** conduct the *qualified inspector* site inspections unless they meet the *qualified inspector* qualifications included in Appendix A. In order to perform these inspections, the *trained contractor* would have to be a:

- licensed Professional Engineer,
 - Certified Professional in Erosion and Sediment Control (CPESC),
 - New York State Erosion and Sediment Control Certificate Program holder
 - Registered Landscape Architect, or
 - someone working under the direct supervision of, and at the same company as, the licensed Professional Engineer or Registered Landscape Architect, provided they have received four (4) hours of Department endorsed training in proper erosion and sediment control principles from a Soil and Water Conservation District, or other Department endorsed entity].
1. A *qualified inspector* shall conduct site inspections for all *construction activities* identified in Tables 1 and 2 of Appendix B, with the exception of:
 - a. the construction of a single family residential subdivision with 25% or less *impervious cover* at total site build-out that involves a soil disturbance of one (1) or more acres of land but less than five (5) acres and is not located

in one of the watersheds listed in Appendix C and not directly discharging to one of the 303(d) segments listed in Appendix E;

- b. the construction of a single family home that involves a soil disturbance of one (1) or more acres of land but less than five (5) acres and is not located in one of the watersheds listed in Appendix C and not directly discharging to one of the 303(d) segments listed in Appendix E;
 - c. construction on agricultural property that involves a soil disturbance of one (1) or more acres of land but less than five (5) acres; and
 - d. *construction activities* located in the watersheds identified in Appendix D that involve soil disturbances between five thousand (5,000) square feet and one (1) acre of land.
2. Unless otherwise notified by the Department, the *qualified inspector* shall conduct site inspections in accordance with the following timetable:
- a. For construction sites where soil disturbance activities are on-going, the *qualified inspector* shall conduct a site inspection at least once every seven (7) calendar days.
 - b. For construction sites where soil disturbance activities are on-going and the *owner or operator* has received authorization in accordance with Part II.D.3 to disturb greater than five (5) acres of soil at any one time, the *qualified inspector* shall conduct at least two (2) site inspections every seven (7) calendar days. The two (2) inspections shall be separated by a minimum of two (2) full calendar days.
 - c. For construction sites where soil disturbance activities have been temporarily suspended (e.g. winter shutdown) and *temporary stabilization* measures have been applied to all disturbed areas, the *qualified inspector* shall conduct a site inspection at least once every thirty (30) calendar days. The *owner or operator* shall notify the DOW Water (SPDES) Program contact at the Regional Office (see contact information in Appendix F) or, in areas under the jurisdiction of a *regulated, traditional land use control MS4*, the *regulated, traditional land use control MS4* (provided the *regulated, traditional land use control MS4* is not the *owner or operator* of the *construction activity*) in writing prior to reducing the frequency of inspections.

- d. For construction sites where soil disturbance activities have been shut down with partial project completion, the *qualified inspector* can stop conducting inspections if all areas disturbed as of the project shutdown date have achieved *final stabilization* and all post-construction stormwater management practices required for the completed portion of the project have been constructed in conformance with the SWPPP and are operational. The *owner or operator* shall notify the DOW Water (SPDES) Program contact at the Regional Office (see contact information in Appendix F) or, in areas under the jurisdiction of a *regulated, traditional land use control MS4*, the *regulated, traditional land use control MS4* (provided the *regulated, traditional land use control MS4* is not the *owner or operator* of the *construction activity*) in writing prior to the shutdown. If soil disturbance activities are not resumed within 2 years from the date of shutdown, the *owner or operator* shall have the *qualified inspector* perform a final inspection and certify that all disturbed areas have achieved *final stabilization*, and all temporary, structural erosion and sediment control measures have been removed; and that all post-construction stormwater management practices have been constructed in conformance with the SWPPP by signing the “*Final Stabilization*” and “*Post-Construction Stormwater Management Practice*” certification statements on the NOT. The *owner or operator* shall then submit the completed NOT form to the address in Part II.B.1 of this permit.
 - e. For construction sites that directly *discharge* to one of the 303(d) segments listed in Appendix E or is located in one of the watersheds listed in Appendix C, the *qualified inspector* shall conduct at least two (2) site inspections every seven (7) calendar days. The two (2) inspections shall be separated by a minimum of two (2) full calendar days.
3. At a minimum, the *qualified inspector* shall inspect all erosion and sediment control practices and pollution prevention measures to ensure integrity and effectiveness, all post-construction stormwater management practices under construction to ensure that they are constructed in conformance with the SWPPP, all areas of disturbance that have not achieved *final stabilization*, all points of *discharge* to natural surface waterbodies located within, or immediately adjacent to, the property boundaries of the *construction site*, and all points of *discharge* from the *construction site*.
 4. The *qualified inspector* shall prepare an inspection report subsequent to each and every inspection. At a minimum, the inspection report shall include and/or address the following:

- a. Date and time of inspection;
- b. Name and title of person(s) performing inspection;
- c. A description of the weather and soil conditions (e.g. dry, wet, saturated) at the time of the inspection;
- d. A description of the condition of the runoff at all points of *discharge* from the *construction site*. This shall include identification of any *discharges* of sediment from the *construction site*. Include *discharges* from conveyance systems (i.e. pipes, culverts, ditches, etc.) and overland flow;
- e. A description of the condition of all natural surface waterbodies located within, or immediately adjacent to, the property boundaries of the *construction site* which receive runoff from disturbed areas. This shall include identification of any *discharges* of sediment to the surface waterbody;
- f. Identification of all erosion and sediment control practices and pollution prevention measures that need repair or maintenance;
- g. Identification of all erosion and sediment control practices and pollution prevention measures that were not installed properly or are not functioning as designed and need to be reinstalled or replaced;
- h. Description and sketch of areas with active soil disturbance activity, areas that have been disturbed but are inactive at the time of the inspection, and areas that have been stabilized (temporary and/or final) since the last inspection;
- i. Current phase of construction of all post-construction stormwater management practices and identification of all construction that is not in conformance with the SWPPP and technical standards;
- j. Corrective action(s) that must be taken to install, repair, replace or maintain erosion and sediment control practices and pollution prevention measures; and to correct deficiencies identified with the construction of the post-construction stormwater management practice(s);
- k. Identification and status of all corrective actions that were required by previous inspection; and

- I. Digital photographs, with date stamp, that clearly show the condition of all practices that have been identified as needing corrective actions. The *qualified inspector* shall attach paper color copies of the digital photographs to the inspection report being maintained onsite within seven (7) calendar days of the date of the inspection. The *qualified inspector* shall also take digital photographs, with date stamp, that clearly show the condition of the practice(s) after the corrective action has been completed. The *qualified inspector* shall attach paper color copies of the digital photographs to the inspection report that documents the completion of the corrective action work within seven (7) calendar days of that inspection.
5. Within one business day of the completion of an inspection, the *qualified inspector* shall notify the *owner or operator* and appropriate contractor or subcontractor identified in Part III.A.6. of this permit of any corrective actions that need to be taken. The contractor or subcontractor shall begin implementing the corrective actions within one business day of this notification and shall complete the corrective actions in a reasonable time frame.
6. All inspection reports shall be signed by the *qualified inspector*. Pursuant to Part II.D.2. of this permit, the inspection reports shall be maintained on site with the SWPPP.

Part V. TERMINATION OF PERMIT COVERAGE

A. Termination of Permit Coverage

1. An *owner or operator* that is eligible to terminate coverage under this permit must submit a completed NOT form to the address in Part II.B.1 of this permit. The NOT form shall be one which is associated with this permit, signed in accordance with Part VII.H of this permit.
2. An *owner or operator* may terminate coverage when one or more the following conditions have been met:
 - a. Total project completion - All *construction activity* identified in the SWPPP has been completed; and all areas of disturbance have achieved *final stabilization*; and all temporary, structural erosion and sediment control measures have been removed; and all post-construction stormwater management practices have been constructed in conformance with the SWPPP and are operational;

- b. Planned shutdown with partial project completion - All soil disturbance activities have ceased; and all areas disturbed as of the project shutdown date have achieved *final stabilization*; and all temporary, structural erosion and sediment control measures have been removed; and all post-construction stormwater management practices required for the completed portion of the project have been constructed in conformance with the SWPPP and are operational;
 - c. A new *owner or operator* has obtained coverage under this permit in accordance with Part II.F. of this permit.
 - d. The *owner or operator* obtains coverage under an alternative SPDES general permit or an individual SPDES permit.
3. For *construction activities* meeting subdivision 2a. or 2b. of this Part, the *owner or operator* shall have the *qualified inspector* perform a final site inspection prior to submitting the NOT. The *qualified inspector* shall, by signing the “*Final Stabilization*” and “Post-Construction Stormwater Management Practice certification statements on the NOT, certify that all the requirements in Part V.A.2.a. or b. of this permit have been achieved.
4. For *construction activities* that are subject to the requirements of a *regulated, traditional land use control MS4* and meet subdivision 2a. or 2b. of this Part, the *owner or operator* shall have the *regulated, traditional land use control MS4* sign the “MS4 Acceptance” statement on the NOT in accordance with the requirements in Part VII.H. of this permit. The *regulated, traditional land use control MS4* official, by signing this statement, has determined that it is acceptable for the *owner or operator* to submit the NOT in accordance with the requirements of this Part. The *regulated, traditional land use control MS4* can make this determination by performing a final site inspection themselves or by accepting the *qualified inspector’s* final site inspection certification(s) required in Part V.A.3. of this permit.
5. For *construction activities* that require post-construction stormwater management practices and meet subdivision 2a. of this Part, the *owner or operator* must, prior to submitting the NOT, ensure one of the following:
 - a. the post-construction stormwater management practice(s) and any right-of-way(s) needed to maintain such practice(s) have been deeded to the municipality in which the practice(s) is located,

- b. an executed maintenance agreement is in place with the municipality that will maintain the post-construction stormwater management practice(s),
- c. for post-construction stormwater management practices that are privately owned, the *owner or operator* has a mechanism in place that requires operation and maintenance of the practice(s) in accordance with the operation and maintenance plan, such as a deed covenant in the *owner or operator's* deed of record,
- d. for post-construction stormwater management practices that are owned by a public or private institution (e.g. school, university, hospital), government agency or authority, or public utility; the *owner or operator* has policy and procedures in place that ensures operation and maintenance of the practices in accordance with the operation and maintenance plan.

Part VI. REPORTING AND RETENTION RECORDS

A. Record Retention

The *owner or operator* shall retain a copy of the NOI, NOI Acknowledgment Letter, SWPPP, MS4 SWPPP Acceptance form and any inspection reports that were prepared in conjunction with this permit for a period of at least five (5) years from the date that the Department receives a complete NOT submitted in accordance with Part V. of this general permit.

B. Addresses

With the exception of the NOI, NOT, and MS4 SWPPP Acceptance form (which must be submitted to the address referenced in Part II.B.1 of this permit), all written correspondence requested by the Department, including individual permit applications, shall be sent to the address of the appropriate DOW Water (SPDES) Program contact at the Regional Office listed in Appendix F.

Part VII. STANDARD PERMIT CONDITIONS

A. Duty to Comply

The *owner or operator* must comply with all conditions of this permit. All contractors and subcontractors associated with the project must comply with the terms of the SWPPP. Any non-compliance with this permit constitutes a violation of the Clean Water

Act (CWA) and the ECL and is grounds for an enforcement action against the *owner or operator* and/or the contractor/subcontractor; permit revocation, suspension or modification; or denial of a permit renewal application. Upon a finding of significant non-compliance with this permit or the applicable SWPPP, the Department may order an immediate stop to all *construction activity* at the site until the non-compliance is remedied. The stop work order shall be in writing, shall describe the non-compliance in detail, and shall be sent to the *owner or operator*.

If any human remains or archaeological remains are encountered during excavation, the *owner or operator* must immediately cease, or cause to cease, all *construction activity* in the area of the remains and notify the appropriate Regional Water Engineer (RWE). *Construction activity* shall not resume until written permission to do so has been received from the RWE.

B. Continuation of the Expired General Permit

This permit expires five (5) years from the effective date. If a new general permit is not issued prior to the expiration of this general permit, an *owner or operator* with coverage under this permit may continue to operate and *discharge* in accordance with the terms and conditions of this general permit, if it is extended pursuant to the State Administrative Procedure Act and 6 NYCRR Part 621, until a new general permit is issued.

C. Enforcement

Failure of the *owner or operator*, its contractors, subcontractors, agents and/or assigns to strictly adhere to any of the permit requirements contained herein shall constitute a violation of this permit. There are substantial criminal, civil, and administrative penalties associated with violating the provisions of this permit. Fines of up to \$37,500 per day for each violation and imprisonment for up to fifteen (15) years may be assessed depending upon the nature and degree of the offense.

D. Need to Halt or Reduce Activity Not a Defense

It shall not be a defense for an *owner or operator* in an enforcement action that it would have been necessary to halt or reduce the *construction activity* in order to maintain compliance with the conditions of this permit.

E. Duty to Mitigate

The *owner or operator* and its contractors and subcontractors shall take all reasonable steps to *minimize* or prevent any *discharge* in violation of this permit which has a reasonable likelihood of adversely affecting human health or the environment.

F. Duty to Provide Information

The *owner or operator* shall furnish to the Department, within a reasonable specified time period of a written request, all documentation necessary to demonstrate eligibility and any information to determine compliance with this permit or to determine whether cause exists for modifying or revoking this permit, or suspending or denying coverage under this permit, in accordance with the terms and conditions of this permit. The NOI, SWPPP and inspection reports required by this permit are public documents that the *owner or operator* must make available for review and copying by any person within five (5) business days of the *owner or operator* receiving a written request by any such person to review these documents. Copying of documents will be done at the requester's expense.

G. Other Information

When the *owner or operator* becomes aware that they failed to submit any relevant facts, or submitted incorrect information in the NOI or in any of the documents required by this permit, or have made substantive revisions to the SWPPP (e.g. the scope of the project changes significantly, the type of post-construction stormwater management practice(s) changes, there is a reduction in the sizing of the post-construction stormwater management practice, or there is an increase in the disturbance area or *impervious area*), which were not reflected in the original NOI submitted to the Department, they shall promptly submit such facts or information to the Department using the contact information in Part II.A. of this permit. Failure of the *owner or operator* to correct or supplement any relevant facts within five (5) business days of becoming aware of the deficiency shall constitute a violation of this permit.

H. Signatory Requirements

1. All NOIs and NOTs shall be signed as follows:
 - a. For a corporation these forms shall be signed by a responsible corporate officer. For the purpose of this section, a responsible corporate officer means:

- (i) a president, secretary, treasurer, or vice-president of the corporation in charge of a principal business function, or any other person who performs similar policy or decision-making functions for the corporation; or
 - (ii) the manager of one or more manufacturing, production or operating facilities, provided the manager is authorized to make management decisions which govern the operation of the regulated facility including having the explicit or implicit duty of making major capital investment recommendations, and initiating and directing other comprehensive measures to assure long term environmental compliance with environmental laws and regulations; the manager can ensure that the necessary systems are established or actions taken to gather complete and accurate information for permit application requirements; and where authority to sign documents has been assigned or delegated to the manager in accordance with corporate procedures;
 - b. For a partnership or sole proprietorship these forms shall be signed by a general partner or the proprietor, respectively; or
 - c. For a municipality, State, Federal, or other public agency these forms shall be signed by either a principal executive officer or ranking elected official. For purposes of this section, a principal executive officer of a Federal agency includes:
 - (i) the chief executive officer of the agency, or
 - (ii) a senior executive officer having responsibility for the overall operations of a principal geographic unit of the agency (e.g., Regional Administrators of EPA).
2. The SWPPP and other information requested by the Department shall be signed by a person described in Part VII.H.1. of this permit or by a duly authorized representative of that person. A person is a duly authorized representative only if:
- a. The authorization is made in writing by a person described in Part VII.H.1. of this permit;
 - b. The authorization specifies either an individual or a position having responsibility for the overall operation of the regulated facility or activity, such as the position of plant manager, operator of a well or a well field,

superintendent, position of *equivalent* responsibility, or an individual or position having overall responsibility for environmental matters for the company. (A duly authorized representative may thus be either a named individual or any individual occupying a named position) and,

- c. The written authorization shall include the name, title and signature of the authorized representative and be attached to the SWPPP.
3. All inspection reports shall be signed by the *qualified inspector* that performs the inspection.
4. The MS4 SWPPP Acceptance form shall be signed by the principal executive officer or ranking elected official from the *regulated, traditional land use control MS4*, or by a duly authorized representative of that person.

It shall constitute a permit violation if an incorrect and/or improper signatory authorizes any required forms, SWPPP and/or inspection reports.

I. Property Rights

The issuance of this permit does not convey any property rights of any sort, nor any exclusive privileges, nor does it authorize any injury to private property nor any invasion of personal rights, nor any infringement of Federal, State or local laws or regulations. *Owners or operators* must obtain any applicable conveyances, easements, licenses and/or access to real property prior to *commencing construction activity*.

J. Severability

The provisions of this permit are severable, and if any provision of this permit, or the application of any provision of this permit to any circumstance, is held invalid, the application of such provision to other circumstances, and the remainder of this permit shall not be affected thereby.

K. Requirement to Obtain Coverage Under an Alternative Permit

1. The Department may require any owner or operator authorized by this permit to apply for and/or obtain either an individual SPDES permit or another SPDES general permit. When the Department requires any discharger authorized by a general permit to apply for an individual SPDES permit, it shall notify the discharger in writing that a permit application is required. This notice shall

include a brief statement of the reasons for this decision, an application form, a statement setting a time frame for the owner or operator to file the application for an individual SPDES permit, and a deadline, not sooner than 180 days from owner or operator receipt of the notification letter, whereby the authorization to discharge under this general permit shall be terminated. Applications must be submitted to the appropriate Permit Administrator at the Regional Office. The Department may grant additional time upon demonstration, to the satisfaction of the Department, that additional time to apply for an alternative authorization is necessary or where the Department has not provided a permit determination in accordance with Part 621 of this Title.

2. When an individual SPDES permit is issued to a discharger authorized to *discharge* under a general SPDES permit for the same *discharge(s)*, the general permit authorization for outfalls authorized under the individual SPDES permit is automatically terminated on the effective date of the individual permit unless termination is earlier in accordance with 6 NYCRR Part 750.

L. Proper Operation and Maintenance

The *owner or operator* shall at all times properly operate and maintain all facilities and systems of treatment and control (and related appurtenances) which are installed or used by the *owner or operator* to achieve compliance with the conditions of this permit and with the requirements of the SWPPP.

M. Inspection and Entry

The *owner or operator* shall allow an authorized representative of the Department, EPA, applicable county health department, or, in the case of a *construction site* which *discharges* through an *MS4*, an authorized representative of the *MS4* receiving the discharge, upon the presentation of credentials and other documents as may be required by law, to:

1. Enter upon the owner's or operator's premises where a regulated facility or activity is located or conducted or where records must be kept under the conditions of this permit;
2. Have access to and copy at reasonable times, any records that must be kept under the conditions of this permit; and

3. Inspect at reasonable times any facilities or equipment (including monitoring and control equipment), practices or operations regulated or required by this permit.
4. Sample or monitor at reasonable times, for purposes of assuring permit compliance or as otherwise authorized by the Act or ECL, any substances or parameters at any location.

N. Permit Actions

This permit may, at any time, be modified, suspended, revoked, or renewed by the Department in accordance with 6 NYCRR Part 621. The filing of a request by the *owner or operator* for a permit modification, revocation and reissuance, termination, a notification of planned changes or anticipated noncompliance does not limit, diminish and/or stay compliance with any terms of this permit.

O. Definitions

Definitions of key terms are included in Appendix A of this permit.

P. Re-Opener Clause

1. If there is evidence indicating potential or realized impacts on water quality due to any stormwater discharge associated with construction activity covered by this permit, the owner or operator of such discharge may be required to obtain an individual permit or alternative general permit in accordance with Part VII.K. of this permit or the permit may be modified to include different limitations and/or requirements.
2. Any Department initiated permit modification, suspension or revocation will be conducted in accordance with 6 NYCRR Part 621, 6 NYCRR 750-1.18, and 6 NYCRR 750-1.20.

Q. Penalties for Falsification of Forms and Reports

In accordance with 6NYCRR Part 750-2.4 and 750-2.5, any person who knowingly makes any false material statement, representation, or certification in any application, record, report or other document filed or required to be maintained under this permit, including reports of compliance or noncompliance shall, upon conviction, be punished in accordance with ECL §71-1933 and or Articles 175 and 210 of the New York State Penal Law.

R. Other Permits

Nothing in this permit relieves the *owner or operator* from a requirement to obtain any other permits required by law.

APPENDIX A – Acronyms and Definitions

Acronyms

APO – Agency Preservation Officer

BMP – Best Management Practice

CPESC – Certified Professional in Erosion and Sediment Control

Cpv – Channel Protection Volume

CWA – Clean Water Act (or the Federal Water Pollution Control Act, 33 U.S.C. §1251 et seq)

DOW – Division of Water

EAF – Environmental Assessment Form

ECL - Environmental Conservation Law

EPA – U. S. Environmental Protection Agency

HSG – Hydrologic Soil Group

MS4 – Municipal Separate Storm Sewer System

NOI – Notice of Intent

NOT – Notice of Termination

NPDES – National Pollutant Discharge Elimination System

OPRHP – Office of Parks, Recreation and Historic Places

Qf – Extreme Flood

Qp – Overbank Flood

RRv – Runoff Reduction Volume

RWE – Regional Water Engineer

SEQR – State Environmental Quality Review

SEQRA - State Environmental Quality Review Act

SHPA – State Historic Preservation Act

SPDES – State Pollutant Discharge Elimination System

SWPPP – Stormwater Pollution Prevention Plan

TMDL – Total Maximum Daily Load

UPA – Uniform Procedures Act

USDA – United States Department of Agriculture

WQv – Water Quality Volume

Definitions

All definitions in this section are solely for the purposes of this permit.

Agricultural Building – a structure designed and constructed to house farm implements, hay, grain, poultry, livestock or other horticultural products; excluding any structure designed, constructed or used, in whole or in part, for human habitation, as a place of employment where agricultural products are processed, treated or packaged, or as a place used by the public.

Agricultural Property – means the land for construction of a barn, *agricultural building*, silo, stockyard, pen or other structural practices identified in Table II in the “Agricultural Management Practices Catalog for Nonpoint Source Pollution in New York State” prepared by the Department in cooperation with agencies of New York Nonpoint Source Coordinating Committee (dated June 2007).

Alter Hydrology from Pre to Post-Development Conditions - means the post-development peak flow rate(s) has increased by more than 5% of the pre-developed condition for the design storm of interest (e.g. 10 yr and 100 yr).

Combined Sewer - means a sewer that is designed to collect and convey both “sewage” and “stormwater”.

Commence (Commencement of) Construction Activities - means the initial disturbance of soils associated with clearing, grading or excavation activities; or other construction related activities that disturb or expose soils such as demolition, stockpiling of fill material, and the initial installation of erosion and sediment control practices required in the SWPPP. See definition for “*Construction Activity(ies)*” also.

Construction Activity(ies) - means any clearing, grading, excavation, filling, demolition or stockpiling activities that result in soil disturbance. Clearing activities can include, but are not limited to, logging equipment operation, the cutting and skidding of trees, stump removal and/or brush root removal. Construction activity does not include routine maintenance that is performed to maintain the original line and grade, hydraulic capacity, or original purpose of a facility.

Construction Site – means the land area where *construction activity(ies)* will occur. See definition for “*Commence (Commencement of) Construction Activities*” and “*Larger Common Plan of Development or Sale*” also.

Dewatering – means the act of draining rainwater and/or groundwater from building foundations, vaults or excavations/trenches.

Direct Discharge (to a specific surface waterbody) - means that runoff flows from a *construction site* by overland flow and the first point of discharge is the specific surface waterbody, or runoff flows from a *construction site* to a separate storm sewer system

and the first point of discharge from the separate storm sewer system is the specific surface waterbody.

Discharge(s) - means any addition of any pollutant to waters of the State through an outlet or *point source*.

Embankment –means an earthen or rock slope that supports a road/highway.

Endangered or Threatened Species – see 6 NYCRR Part 182 of the Department’s rules and regulations for definition of terms and requirements.

Environmental Conservation Law (ECL) - means chapter 43-B of the Consolidated Laws of the State of New York, entitled the Environmental Conservation Law.

Equivalent (Equivalence) – means that the practice or measure meets all the performance, longevity, maintenance, and safety objectives of the technical standard and will provide an equal or greater degree of water quality protection.

Final Stabilization - means that all soil disturbance activities have ceased and a uniform, perennial vegetative cover with a density of eighty (80) percent over the entire pervious surface has been established; or other equivalent stabilization measures, such as permanent landscape mulches, rock rip-rap or washed/crushed stone have been applied on all disturbed areas that are not covered by permanent structures, concrete or pavement.

General SPDES permit - means a SPDES permit issued pursuant to 6 NYCRR Part 750-1.21 and Section 70-0117 of the ECL authorizing a category of discharges.

Groundwater(s) - means waters in the saturated zone. The saturated zone is a subsurface zone in which all the interstices are filled with water under pressure greater than that of the atmosphere. Although the zone may contain gas-filled interstices or interstices filled with fluids other than water, it is still considered saturated.

Historic Property – means any building, structure, site, object or district that is listed on the State or National Registers of Historic Places or is determined to be eligible for listing on the State or National Registers of Historic Places.

Impervious Area (Cover) - means all impermeable surfaces that cannot effectively infiltrate rainfall. This includes paved, concrete and gravel surfaces (i.e. parking lots, driveways, roads, runways and sidewalks); building rooftops and miscellaneous impermeable structures such as patios, pools, and sheds.

Infeasible – means not technologically possible, or not economically practicable and achievable in light of best industry practices.

Larger Common Plan of Development or Sale - means a contiguous area where multiple separate and distinct *construction activities* are occurring, or will occur, under one plan. The term “plan” in “larger common plan of development or sale” is broadly defined as any announcement or piece of documentation (including a sign, public notice or hearing, marketing plan, advertisement, drawing, permit application, State Environmental Quality Review Act (SEQRA) environmental assessment form or other documents, zoning request, computer design, etc.) or physical demarcation (including boundary signs, lot stakes, surveyor markings, etc.) indicating that *construction activities* may occur on a specific plot.

For discrete construction projects that are located within a larger common plan of development or sale that are at least 1/4 mile apart, each project can be treated as a separate plan of development or sale provided any interconnecting road, pipeline or utility project that is part of the same “common plan” is not concurrently being disturbed.

Minimize – means reduce and/or eliminate to the extent achievable using control measures (including best management practices) that are technologically available and economically practicable and achievable in light of best industry practices.

Municipal Separate Storm Sewer (MS4) - a conveyance or system of conveyances (including roads with drainage systems, municipal streets, catch basins, curbs, gutters, ditches, man-made channels, or storm drains):

- (i) Owned or operated by a State, city, town, borough, county, parish, district, association, or other public body (created by or pursuant to State law) having jurisdiction over disposal of sewage, industrial wastes, stormwater, or other wastes, including special districts under State law such as a sewer district, flood control district or drainage district, or similar entity, or an Indian tribe or an authorized Indian tribal organization, or a designated and approved management agency under section 208 of the CWA that discharges to surface waters of the State;
- (ii) Designed or used for collecting or conveying stormwater;
- (iii) Which is not a *combined sewer*; and
- (iv) Which is not part of a Publicly Owned Treatment Works (POTW) as defined at 40 CFR 122.2.

National Pollutant Discharge Elimination System (NPDES) - means the national system for the issuance of wastewater and stormwater permits under the Federal Water Pollution Control Act (Clean Water Act).

Natural Buffer –means an undisturbed area with natural cover running along a surface water (e.g. wetland, stream, river, lake, etc.).

New Development – means any land disturbance that does not meet the definition of Redevelopment Activity included in this appendix.

New York State Erosion and Sediment Control Certificate Program – a certificate program that establishes and maintains a process to identify and recognize individuals who are capable of developing, designing, inspecting and maintaining erosion and sediment control plans on projects that disturb soils in New York State. The certificate program is administered by the New York State Conservation District Employees Association.

NOI Acknowledgment Letter - means the letter that the Department sends to an owner or operator to acknowledge the Department's receipt and acceptance of a complete Notice of Intent. This letter documents the owner's or operator's authorization to discharge in accordance with the general permit for stormwater discharges from *construction activity*.

Nonpoint Source - means any source of water pollution or pollutants which is not a discrete conveyance or *point source* permitted pursuant to Title 7 or 8 of Article 17 of the Environmental Conservation Law (see ECL Section 17-1403).

Overbank –means flow events that exceed the capacity of the stream channel and spill out into the adjacent floodplain.

Owner or Operator - means the person, persons or legal entity which owns or leases the property on which the *construction activity* is occurring; an entity that has operational control over the construction plans and specifications, including the ability to make modifications to the plans and specifications; and/or an entity that has day-to-day operational control of those activities at a project that are necessary to ensure compliance with the permit conditions.

Performance Criteria – means the design criteria listed under the “Required Elements” sections in Chapters 5, 6 and 10 of the technical standard, New York State Stormwater Management Design Manual, dated January 2015. It does not include the Sizing Criteria (i.e. WQv, RRv, Cpv, Qp and Qf) in Part I.C.2. of the permit.

Point Source - means any discernible, confined and discrete conveyance, including but not limited to any pipe, ditch, channel, tunnel, conduit, well, discrete fissure, container, rolling stock, concentrated animal feeding operation, vessel or other floating craft, or landfill leachate collection system from which *pollutants* are or may be discharged.

Pollutant - means dredged spoil, filter backwash, solid waste, incinerator residue, sewage, garbage, sewage sludge, munitions, chemical wastes, biological materials, radioactive materials, heat, wrecked or discarded equipment, rock, sand and industrial, municipal, agricultural waste and ballast discharged into water; which may cause or might reasonably be expected to cause pollution of the waters of the state in contravention of the standards or guidance values adopted as provided in 6 NYCRR Parts 700 et seq .

Qualified Inspector - means a person that is knowledgeable in the principles and practices of erosion and sediment control, such as a licensed Professional Engineer, Certified Professional in Erosion and Sediment Control (CPESC), Registered Landscape Architect, New York State Erosion and Sediment Control Certificate Program holder or other Department endorsed individual(s).

It can also mean someone working under the direct supervision of, and at the same company as, the licensed Professional Engineer or Registered Landscape Architect, provided that person has training in the principles and practices of erosion and sediment control. Training in the principles and practices of erosion and sediment control means that the individual working under the direct supervision of the licensed Professional Engineer or Registered Landscape Architect has received four (4) hours of Department endorsed training in proper erosion and sediment control principles from a Soil and Water Conservation District, or other Department endorsed entity. After receiving the initial training, the individual working under the direct supervision of the licensed Professional Engineer or Registered Landscape Architect shall receive four (4) hours of training every three (3) years.

It can also mean a person that meets the *Qualified Professional* qualifications in addition to the *Qualified Inspector* qualifications.

Note: Inspections of any post-construction stormwater management practices that include structural components, such as a dam for an impoundment, shall be performed by a licensed Professional Engineer.

Qualified Professional - means a person that is knowledgeable in the principles and practices of stormwater management and treatment, such as a licensed Professional Engineer, Registered Landscape Architect or other Department endorsed individual(s). Individuals preparing SWPPPs that require the post-construction stormwater management practice component must have an understanding of the principles of hydrology, water quality management practice design, water quantity control design, and, in many cases, the principles of hydraulics. All components of the SWPPP that involve the practice of engineering, as defined by the NYS Education Law (see Article 145), shall be prepared by, or under the direct supervision of, a professional engineer licensed to practice in the State of New York.

Redevelopment Activity(ies) – means the disturbance and reconstruction of existing impervious area, including impervious areas that were removed from a project site within five (5) years of preliminary project plan submission to the local government (i.e. site plan, subdivision, etc.).

Regulated, Traditional Land Use Control MS4 - means a city, town or village with land use control authority that is authorized to discharge under New York State DEC's

SPDES General Permit For Stormwater Discharges from Municipal Separate Stormwater Sewer Systems (MS4s) or the City of New York's Individual SPDES Permit for their Municipal Separate Storm Sewer Systems (NY-0287890).

Routine Maintenance Activity - means *construction activity* that is performed to maintain the original line and grade, hydraulic capacity, or original purpose of a facility, including, but not limited to:

- Re-grading of gravel roads or parking lots,
- Cleaning and shaping of existing roadside ditches and culverts that maintains the approximate original line and grade, and hydraulic capacity of the ditch,
- Cleaning and shaping of existing roadside ditches that does not maintain the approximate original grade, hydraulic capacity and purpose of the ditch if the changes to the line and grade, hydraulic capacity or purpose of the ditch are installed to improve water quality and quantity controls (e.g. installing grass lined ditch),
- Placement of aggregate shoulder backing that stabilizes the transition between the road shoulder and the ditch or *embankment*,
- Full depth milling and filling of existing asphalt pavements, replacement of concrete pavement slabs, and similar work that does not expose soil or disturb the bottom six (6) inches of subbase material,
- Long-term use of equipment storage areas at or near highway maintenance facilities,
- Removal of sediment from the edge of the highway to restore a previously existing sheet-flow drainage connection from the highway surface to the highway ditch or *embankment*,
- Existing use of Canal Corp owned upland disposal sites for the canal, and
- Replacement of curbs, gutters, sidewalks and guide rail posts.

Site limitations – means site conditions that prevent the use of an infiltration technique and or infiltration of the total WQv. Typical site limitations include: seasonal high groundwater, shallow depth to bedrock, and soils with an infiltration rate less than 0.5 inches/hour. The existence of site limitations shall be confirmed and documented using actual field testing (i.e. test pits, soil borings, and infiltration test) or using information from the most current United States Department of Agriculture (USDA) Soil Survey for the County where the project is located.

Sizing Criteria – means the criteria included in Part I.C.2 of the permit that are used to size post-construction stormwater management control practices. The criteria include; Water Quality Volume (WQv), Runoff Reduction Volume (RRv), Channel Protection Volume (Cpv), *Overbank Flood* (Qp), and Extreme Flood (Qf).

State Pollutant Discharge Elimination System (SPDES) - means the system established pursuant to Article 17 of the ECL and 6 NYCRR Part 750 for issuance of permits authorizing discharges to the waters of the state.

Steep Slope – means land area designated on the current United States Department of Agriculture (“USDA”) Soil Survey as Soil Slope Phase “D”, (provided the map unit name is inclusive of slopes greater than 25%) , or Soil Slope Phase E or F, (regardless of the map unit name), or a combination of the three designations.

Streambank – as used in this permit, means the terrain alongside the bed of a creek or stream. The bank consists of the sides of the channel, between which the flow is confined.

Stormwater Pollution Prevention Plan (SWPPP) – means a project specific report, including construction drawings, that among other things: describes the construction activity(ies), identifies the potential sources of pollution at the *construction site*; describes and shows the stormwater controls that will be used to control the pollutants (i.e. erosion and sediment controls; for many projects, includes post-construction stormwater management controls); and identifies procedures the *owner or operator* will implement to comply with the terms and conditions of the permit. See Part III of the permit for a complete description of the information that must be included in the SWPPP.

Surface Waters of the State - shall be construed to include lakes, bays, sounds, ponds, impounding reservoirs, springs, rivers, streams, creeks, estuaries, marshes, inlets, canals, the Atlantic ocean within the territorial seas of the state of New York and all other bodies of surface water, natural or artificial, inland or coastal, fresh or salt, public or private (except those private waters that do not combine or effect a junction with natural surface waters), which are wholly or partially within or bordering the state or within its jurisdiction. Waters of the state are further defined in 6 NYCRR Parts 800 to 941.

Temporarily Ceased – means that an existing disturbed area will not be disturbed again within 14 calendar days of the previous soil disturbance.

Temporary Stabilization - means that exposed soil has been covered with material(s) as set forth in the technical standard, New York Standards and Specifications for Erosion and Sediment Control, to prevent the exposed soil from eroding. The materials can include, but are not limited to, mulch, seed and mulch, and erosion control mats (e.g. jute twisted yarn, excelsior wood fiber mats).

Total Maximum Daily Loads (TMDLs) - A TMDL is the sum of the allowable loads of a single pollutant from all contributing point and *nonpoint sources*. It is a calculation of the maximum amount of a pollutant that a waterbody can receive on a daily basis and still meet *water quality standards*, and an allocation of that amount to the pollutant's sources. A TMDL stipulates wasteload allocations (WLAs) for *point source* discharges, load allocations (LAs) for *nonpoint sources*, and a margin of safety (MOS).

Trained Contractor - means an employee from the contracting (construction) company, identified in Part III.A.6., that has received four (4) hours of Department endorsed

training in proper erosion and sediment control principles from a Soil and Water Conservation District, or other Department endorsed entity. After receiving the initial training, the *trained contractor* shall receive four (4) hours of training every three (3) years.

It can also mean an employee from the contracting (construction) company, identified in Part III.A.6., that meets the *qualified inspector* qualifications (e.g. licensed Professional Engineer, Certified Professional in Erosion and Sediment Control (CPESC), Registered Landscape Architect, New York State Erosion and Sediment Control Certificate Program holder, or someone working under the direct supervision of, and at the same company as, the licensed Professional Engineer or Registered Landscape Architect, provided they have received four (4) hours of Department endorsed training in proper erosion and sediment control principles from a Soil and Water Conservation District, or other Department endorsed entity).

The *trained contractor* is responsible for the day to day implementation of the SWPPP.

Uniform Procedures Act (UPA) Permit - means a permit required under 6 NYCRR Part 621 of the Environmental Conservation Law (ECL), Article 70.

Water Quality Standard - means such measures of purity or quality for any waters in relation to their reasonable and necessary use as promulgated in 6 NYCRR Part 700 et seq.

APPENDIX B – Required SWPPP Components by Project Type

Table 1
Construction Activities that Require the Preparation of a SWPPP That Only Includes Erosion and Sediment Controls

<p>The following construction activities that involve soil disturbances of one (1) or more acres of land, but less than five (5) acres:</p> <ul style="list-style-type: none">• Single family home <u>not</u> located in one of the watersheds listed in Appendix C or <u>not directly discharging</u> to one of the 303(d) segments listed in Appendix E• Single family residential subdivisions with 25% or less impervious cover at total site build-out and <u>not</u> located in one of the watersheds listed in Appendix C and <u>not</u> directly discharging to one of the 303(d) segments listed in Appendix E• Construction of a barn or other <i>agricultural building</i>, silo, stock yard or pen.
<p>The following construction activities that involve soil disturbances between five thousand (5000) square feet and one (1) acre of land:</p> <p>All construction activities located in the watersheds identified in Appendix D that involve soil disturbances between five thousand (5,000) square feet and one (1) acre of land.</p>
<p>The following construction activities that involve soil disturbances of one (1) or more acres of land:</p> <ul style="list-style-type: none">• Installation of underground, linear utilities; such as gas lines, fiber-optic cable, cable TV, electric, telephone, sewer mains, and water mains• Environmental enhancement projects, such as wetland mitigation projects, stormwater retrofits and stream restoration projects• Pond construction• Linear bike paths running through areas with vegetative cover, including bike paths surfaced with an impervious cover• Cross-country ski trails and walking/hiking trails• Sidewalk, bike path or walking path projects, surfaced with an impervious cover, that are not part of residential, commercial or institutional development;• Sidewalk, bike path or walking path projects, surfaced with an impervious cover, that include incidental shoulder or curb work along an existing highway to support construction of the sidewalk, bike path or walking path.• Slope stabilization projects• Slope flattening that changes the grade of the site, but does not significantly change the runoff characteristics

Table 1 (Continued) CONSTRUCTION ACTIVITIES THAT REQUIRE THE PREPARATION OF A SWPPP THAT ONLY INCLUDES EROSION AND SEDIMENT CONTROLS

The following construction activities that involve soil disturbances of one (1) or more acres of land:

- Spoil areas that will be covered with vegetation
- Vegetated open space projects (i.e. recreational parks, lawns, meadows, fields, downhill ski trails) excluding projects that *alter hydrology from pre to post development* conditions,
- Athletic fields (natural grass) that do not include the construction or reconstruction of *impervious area* and do not *alter hydrology from pre to post development* conditions
- Demolition project where vegetation will be established, and no redevelopment is planned
- Overhead electric transmission line project that does not include the construction of permanent access roads or parking areas surfaced with *impervious cover*
- Structural practices as identified in Table II in the “Agricultural Management Practices Catalog for Nonpoint Source Pollution in New York State”, excluding projects that involve soil disturbances of greater than five acres and construction activities that include the construction or reconstruction of impervious area
- Temporary access roads, median crossovers, detour roads, lanes, or other temporary impervious areas that will be restored to pre-construction conditions once the construction activity is complete

Table 2
CONSTRUCTION ACTIVITIES THAT REQUIRE THE PREPARATION OF A SWPPP THAT INCLUDES
POST-CONSTRUCTION STORMWATER MANAGEMENT PRACTICES

The following construction activities that involve soil disturbances of one (1) or more acres of land:

- Single family home located in one of the watersheds listed in Appendix C or *directly discharging* to one of the 303(d) segments listed in Appendix E
- Single family home that disturbs five (5) or more acres of land
- Single family residential subdivisions located in one of the watersheds listed in Appendix C or *directly discharging* to one of the 303(d) segments listed in Appendix E
- Single family residential subdivisions that involve soil disturbances of between one (1) and five (5) acres of land with greater than 25% impervious cover at total site build-out
- Single family residential subdivisions that involve soil disturbances of five (5) or more acres of land, and single family residential subdivisions that involve soil disturbances of less than five (5) acres that are part of a larger common plan of development or sale that will ultimately disturb five or more acres of land
- Multi-family residential developments; includes duplexes, townhomes, condominiums, senior housing complexes, apartment complexes, and mobile home parks
- Airports
- Amusement parks
- Breweries, cideries, and wineries, including establishments constructed on agricultural land
- Campgrounds
- Cemeteries that include the construction or reconstruction of impervious area (>5% of disturbed area) or *alter the hydrology from pre to post development* conditions
- Commercial developments
- Churches and other places of worship
- Construction of a barn or other *agricultural building* (e.g. silo) and structural practices as identified in Table II in the "Agricultural Management Practices Catalog for Nonpoint Source Pollution in New York State" that include the construction or reconstruction of *impervious area*, excluding projects that involve soil disturbances of less than five acres.
- Golf courses
- Institutional development; includes hospitals, prisons, schools and colleges
- Industrial facilities; includes industrial parks
- Landfills
- Municipal facilities; includes highway garages, transfer stations, office buildings, POTW's, water treatment plants, and water storage tanks
- Office complexes
- Playgrounds that include the construction or reconstruction of impervious area
- Sports complexes
- Racetracks; includes racetracks with earthen (dirt) surface
- Road construction or reconstruction, including roads constructed as part of the construction activities listed in Table 1

Table 2 (Continued)

CONSTRUCTION ACTIVITIES THAT REQUIRE THE PREPARATION OF A SWPPP THAT INCLUDES POST-CONSTRUCTION STORMWATER MANAGEMENT PRACTICES

The following construction activities that involve soil disturbances of one (1) or more acres of land:

- Parking lot construction or reconstruction, including parking lots constructed as part of the construction activities listed in Table 1
- Athletic fields (natural grass) that include the construction or reconstruction of impervious area (>5% of disturbed area) or *alter the hydrology from pre to post development* conditions
- Athletic fields with artificial turf
- Permanent access roads, parking areas, substations, compressor stations and well drilling pads, surfaced with *impervious cover*, and constructed as part of an over-head electric transmission line project, wind-power project, cell tower project, oil or gas well drilling project, sewer or water main project or other linear utility project
- Sidewalk, bike path or walking path projects, surfaced with an impervious cover, that are part of a residential, commercial or institutional development
- Sidewalk, bike path or walking path projects, surfaced with an impervious cover, that are part of a highway construction or reconstruction project
- All other construction activities that include the construction or reconstruction of *impervious area* or *alter the hydrology from pre to post development* conditions, and are not listed in Table 1

APPENDIX C – Watersheds Requiring Enhanced Phosphorus Removal

Watersheds where *owners or operators* of construction activities identified in Table 2 of Appendix B must prepare a SWPPP that includes post-construction stormwater management practices designed in conformance with the Enhanced Phosphorus Removal Standards included in the technical standard, New York State Stormwater Management Design Manual (“Design Manual”).

- Entire New York City Watershed located east of the Hudson River - Figure 1
- Onondaga Lake Watershed - Figure 2
- Greenwood Lake Watershed -Figure 3
- Oscawana Lake Watershed – Figure 4
- Kinderhook Lake Watershed – Figure 5

Figure 1 - New York City Watershed East of the Hudson

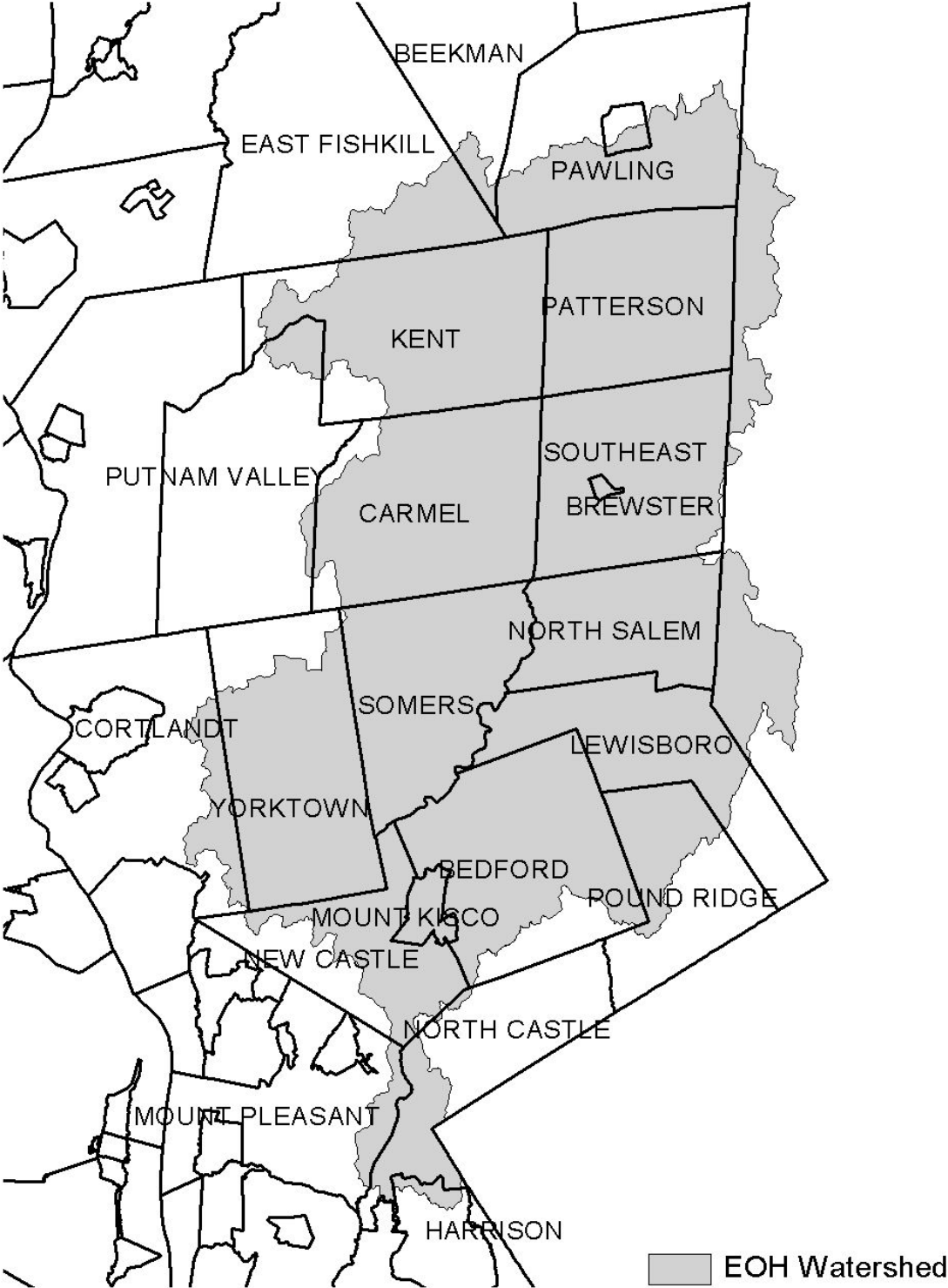

Figure 2 - Onondaga Lake Watershed



Figure 3 - Greenwood Lake Watershed

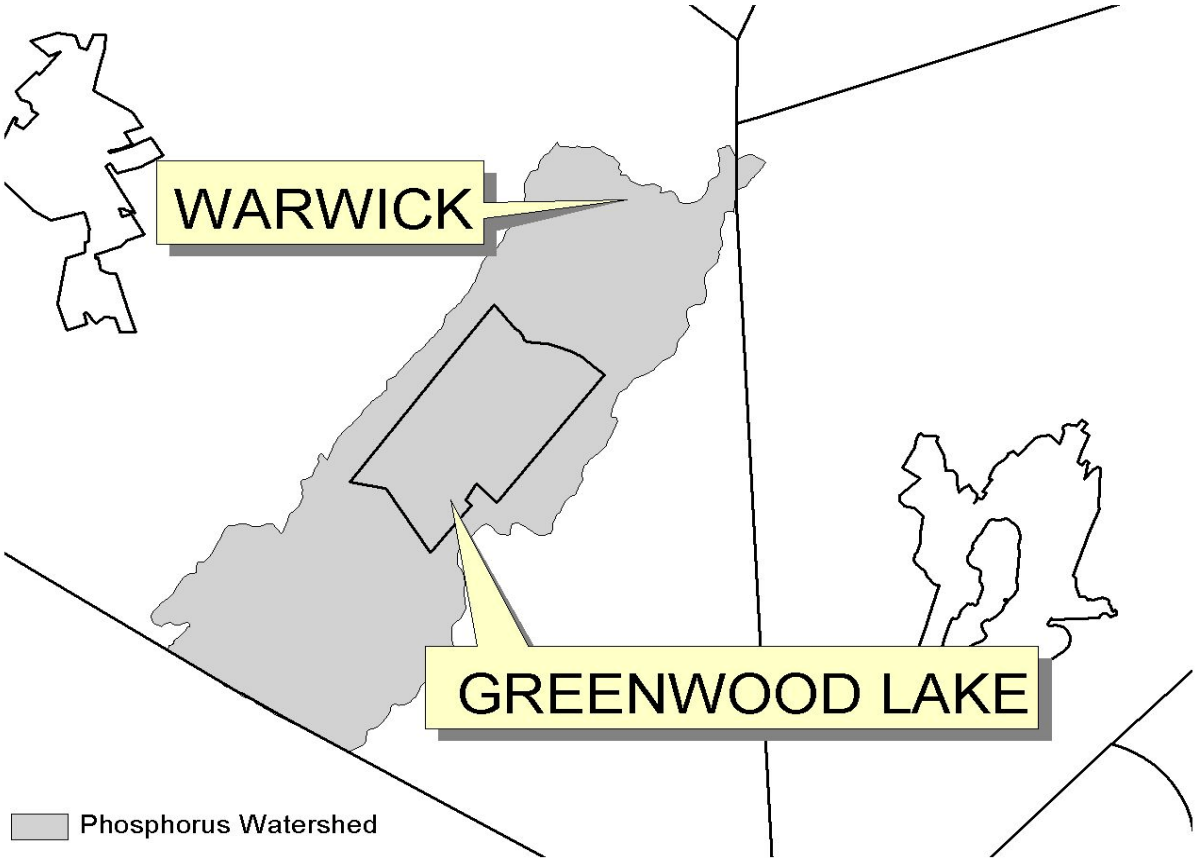

Figure 4 - Oscawana Lake Watershed

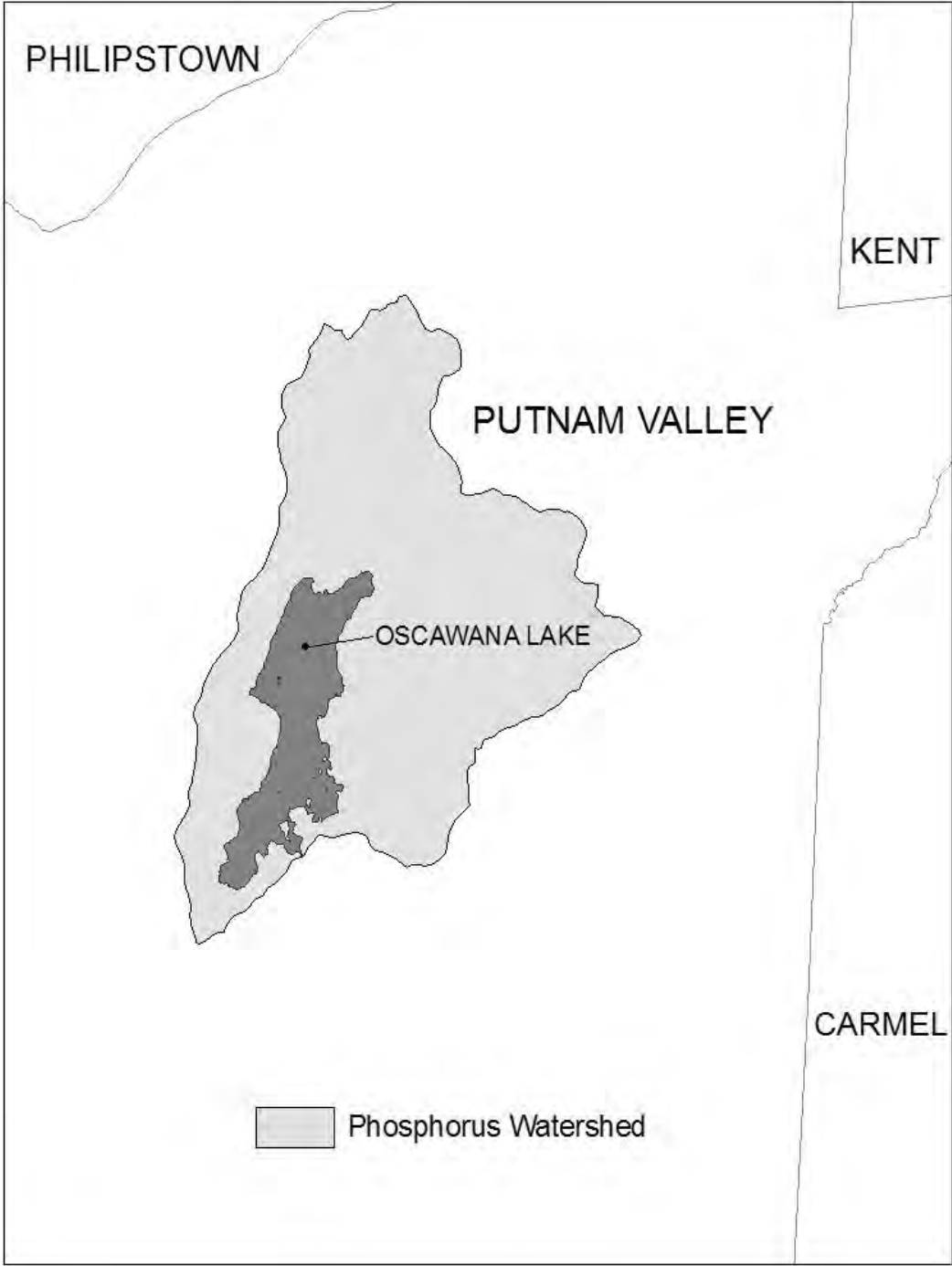
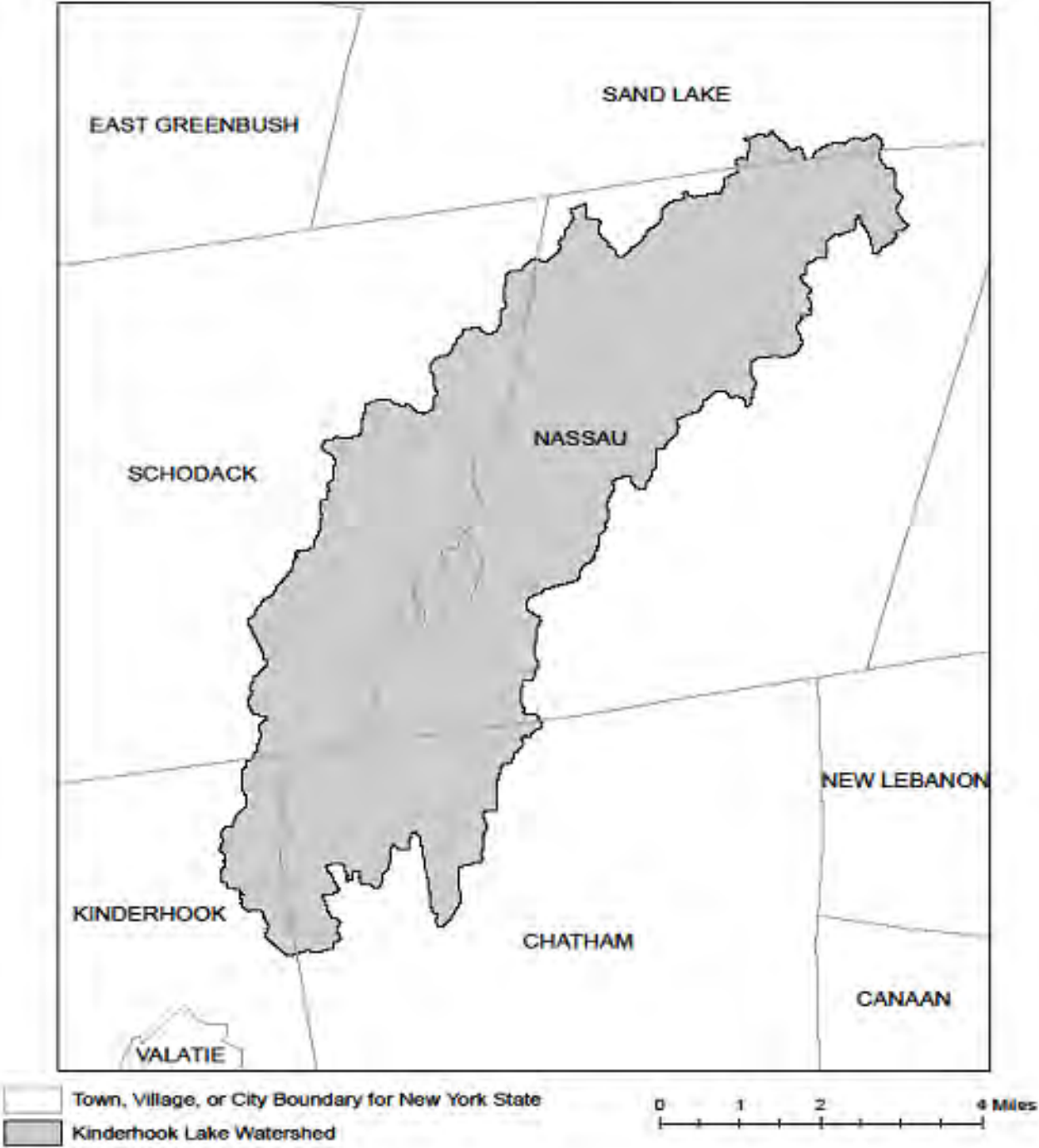

Figure 5 - Kinderhook Lake Watershed



APPENDIX D – Watersheds with Lower Disturbance Threshold

Watersheds where *owners or operators* of construction activities that involve soil disturbances between five thousand (5000) square feet and one (1) acre of land must obtain coverage under this permit.

Entire New York City Watershed that is located east of the Hudson River - See Figure 1 in Appendix C

APPENDIX E – 303(d) Segments Impaired by Construction Related Pollutant(s)

List of 303(d) segments impaired by pollutants related to *construction activity* (e.g. silt, sediment or nutrients). The list was developed using "The Final New York State 2016 Section 303(d) List of Impaired Waters Requiring a TMDL/Other Strategy" dated November 2016. *Owners or operators* of single family home and single family residential subdivisions with 25% or less total impervious cover at total site build-out that involve soil disturbances of one or more acres of land, but less than 5 acres, and *directly discharge* to one of the listed segments below shall prepare a SWPPP that includes post-construction stormwater management practices designed in conformance with the New York State Stormwater Management Design Manual ("Design Manual"), dated January 2015.

COUNTY	WATERBODY	POLLUTANT
Albany	Ann Lee (Shakers) Pond, Stump Pond	Nutrients
Albany	Basic Creek Reservoir	Nutrients
Allegany	Amity Lake, Saunders Pond	Nutrients
Bronx	Long Island Sound, Bronx	Nutrients
Bronx	Van Cortlandt Lake	Nutrients
Broome	Fly Pond, Deer Lake, Sky Lake	Nutrients
Broome	Minor Tribs to Lower Susquehanna (north)	Nutrients
Broome	Whitney Point Lake/Reservoir	Nutrients
Cattaraugus	Allegheny River/Reservoir	Nutrients
Cattaraugus	Beaver (Alma) Lake	Nutrients
Cattaraugus	Case Lake	Nutrients
Cattaraugus	Linlyco/Club Pond	Nutrients
Cayuga	Duck Lake	Nutrients
Cayuga	Little Sodus Bay	Nutrients
Chautauqua	Bear Lake	Nutrients
Chautauqua	Chadakoin River and tribs	Nutrients
Chautauqua	Chautauqua Lake, North	Nutrients
Chautauqua	Chautauqua Lake, South	Nutrients
Chautauqua	Findley Lake	Nutrients
Chautauqua	Hulburt/Clymer Pond	Nutrients
Clinton	Great Chazy River, Lower, Main Stem	Silt/Sediment
Clinton	Lake Champlain, Main Lake, Middle	Nutrients
Clinton	Lake Champlain, Main Lake, North	Nutrients
Columbia	Kinderhook Lake	Nutrients
Columbia	Robinson Pond	Nutrients
Cortland	Dean Pond	Nutrients

303(d) Segments Impaired by Construction Related Pollutant(s)

Dutchess	Fall Kill and tribs	Nutrients
Dutchess	Hillside Lake	Nutrients
Dutchess	Wappingers Lake	Nutrients
Dutchess	Wappingers Lake	Silt/Sediment
Erie	Beeman Creek and tribs	Nutrients
Erie	Ellicott Creek, Lower, and tribs	Silt/Sediment
Erie	Ellicott Creek, Lower, and tribs	Nutrients
Erie	Green Lake	Nutrients
Erie	Little Sister Creek, Lower, and tribs	Nutrients
Erie	Murder Creek, Lower, and tribs	Nutrients
Erie	Rush Creek and tribs	Nutrients
Erie	Scajaquada Creek, Lower, and tribs	Nutrients
Erie	Scajaquada Creek, Middle, and tribs	Nutrients
Erie	Scajaquada Creek, Upper, and tribs	Nutrients
Erie	South Branch Smoke Cr, Lower, and tribs	Silt/Sediment
Erie	South Branch Smoke Cr, Lower, and tribs	Nutrients
Essex	Lake Champlain, Main Lake, South	Nutrients
Essex	Lake Champlain, South Lake	Nutrients
Essex	Willsboro Bay	Nutrients
Genesee	Bigelow Creek and tribs	Nutrients
Genesee	Black Creek, Middle, and minor tribs	Nutrients
Genesee	Black Creek, Upper, and minor tribs	Nutrients
Genesee	Bowen Brook and tribs	Nutrients
Genesee	LeRoy Reservoir	Nutrients
Genesee	Oak Orchard Cr, Upper, and tribs	Nutrients
Genesee	Tonawanda Creek, Middle, Main Stem	Nutrients
Greene	Schoharie Reservoir	Silt/Sediment
Greene	Sleepy Hollow Lake	Silt/Sediment
Herkimer	Steele Creek tribs	Silt/Sediment
Herkimer	Steele Creek tribs	Nutrients
Jefferson	Moon Lake	Nutrients
Kings	Hendrix Creek	Nutrients
Kings	Prospect Park Lake	Nutrients
Lewis	Mill Creek/South Branch, and tribs	Nutrients
Livingston	Christie Creek and tribs	Nutrients
Livingston	Conesus Lake	Nutrients
Livingston	Mill Creek and minor tribs	Silt/Sediment
Monroe	Black Creek, Lower, and minor tribs	Nutrients
Monroe	Buck Pond	Nutrients
Monroe	Cranberry Pond	Nutrients

303(d) Segments Impaired by Construction Related Pollutant(s)

Monroe	Lake Ontario Shoreline, Western	Nutrients
Monroe	Long Pond	Nutrients
Monroe	Mill Creek and tribs	Nutrients
Monroe	Mill Creek/Blue Pond Outlet and tribs	Nutrients
Monroe	Minor Tribs to Irondequoit Bay	Nutrients
Monroe	Rochester Embayment - East	Nutrients
Monroe	Rochester Embayment - West	Nutrients
Monroe	Shipbuilders Creek and tribs	Nutrients
Monroe	Thomas Creek/White Brook and tribs	Nutrients
Nassau	Beaver Lake	Nutrients
Nassau	Camaans Pond	Nutrients
Nassau	East Meadow Brook, Upper, and tribs	Silt/Sediment
Nassau	East Rockaway Channel	Nutrients
Nassau	Grant Park Pond	Nutrients
Nassau	Hempstead Bay	Nutrients
Nassau	Hempstead Lake	Nutrients
Nassau	Hewlett Bay	Nutrients
Nassau	Hog Island Channel	Nutrients
Nassau	Long Island Sound, Nassau County Waters	Nutrients
Nassau	Massapequa Creek and tribs	Nutrients
Nassau	Milburn/Parsonage Creeks, Upp, and tribs	Nutrients
Nassau	Reynolds Channel, west	Nutrients
Nassau	Tidal Tribs to Hempstead Bay	Nutrients
Nassau	Tribs (fresh) to East Bay	Nutrients
Nassau	Tribs (fresh) to East Bay	Silt/Sediment
Nassau	Tribs to Smith/Halls Ponds	Nutrients
Nassau	Woodmere Channel	Nutrients
New York	Harlem Meer	Nutrients
New York	The Lake in Central Park	Nutrients
Niagara	Bergholtz Creek and tribs	Nutrients
Niagara	Hyde Park Lake	Nutrients
Niagara	Lake Ontario Shoreline, Western	Nutrients
Niagara	Lake Ontario Shoreline, Western	Nutrients
Oneida	Ballou, Nail Creeks and tribs	Nutrients
Onondaga	Harbor Brook, Lower, and tribs	Nutrients
Onondaga	Ley Creek and tribs	Nutrients
Onondaga	Minor Tribs to Onondaga Lake	Nutrients
Onondaga	Ninemile Creek, Lower, and tribs	Nutrients
Onondaga	Onondaga Creek, Lower, and tribs	Nutrients
Onondaga	Onondaga Creek, Middle, and tribs	Nutrients

303(d) Segments Impaired by Construction Related Pollutant(s)

Onondaga	Onondaga Lake, northern end	Nutrients
Onondaga	Onondaga Lake, southern end	Nutrients
Ontario	Great Brook and minor tribs	Silt/Sediment
Ontario	Great Brook and minor tribs	Nutrients
Ontario	Hemlock Lake Outlet and minor tribs	Nutrients
Ontario	Honeoye Lake	Nutrients
Orange	Greenwood Lake	Nutrients
Orange	Monhagen Brook and tribs	Nutrients
Orange	Orange Lake	Nutrients
Orleans	Lake Ontario Shoreline, Western	Nutrients
Orleans	Lake Ontario Shoreline, Western	Nutrients
Oswego	Lake Neatahwanta	Nutrients
Oswego	Pleasant Lake	Nutrients
Putnam	Bog Brook Reservoir	Nutrients
Putnam	Boyd Corners Reservoir	Nutrients
Putnam	Croton Falls Reservoir	Nutrients
Putnam	Diverting Reservoir	Nutrients
Putnam	East Branch Reservoir	Nutrients
Putnam	Lake Carmel	Nutrients
Putnam	Middle Branch Reservoir	Nutrients
Putnam	Oscawana Lake	Nutrients
Putnam	Palmer Lake	Nutrients
Putnam	West Branch Reservoir	Nutrients
Queens	Bergen Basin	Nutrients
Queens	Flushing Creek/Bay	Nutrients
Queens	Jamaica Bay, Eastern, and tribs (Queens)	Nutrients
Queens	Kissena Lake	Nutrients
Queens	Meadow Lake	Nutrients
Queens	Willow Lake	Nutrients
Rensselaer	Nassau Lake	Nutrients
Rensselaer	Snyders Lake	Nutrients
Richmond	Grasmere Lake/Bradys Pond	Nutrients
Rockland	Congers Lake, Swartout Lake	Nutrients
Rockland	Rockland Lake	Nutrients
Saratoga	Ballston Lake	Nutrients
Saratoga	Dwaas Kill and tribs	Silt/Sediment
Saratoga	Dwaas Kill and tribs	Nutrients
Saratoga	Lake Lonely	Nutrients
Saratoga	Round Lake	Nutrients
Saratoga	Tribs to Lake Lonely	Nutrients

303(d) Segments Impaired by Construction Related Pollutant(s)

Schenectady	Collins Lake	Nutrients
Schenectady	Duane Lake	Nutrients
Schenectady	Mariaville Lake	Nutrients
Schoharie	Engleville Pond	Nutrients
Schoharie	Summit Lake	Nutrients
Seneca	Reeder Creek and tribs	Nutrients
St.Lawrence	Black Lake Outlet/Black Lake	Nutrients
St.Lawrence	Fish Creek and minor tribs	Nutrients
Steuben	Smith Pond	Nutrients
Suffolk	Agawam Lake	Nutrients
Suffolk	Big/Little Fresh Ponds	Nutrients
Suffolk	Canaan Lake	Silt/Sediment
Suffolk	Canaan Lake	Nutrients
Suffolk	Flanders Bay, West/Lower Sawmill Creek	Nutrients
Suffolk	Fresh Pond	Nutrients
Suffolk	Great South Bay, East	Nutrients
Suffolk	Great South Bay, Middle	Nutrients
Suffolk	Great South Bay, West	Nutrients
Suffolk	Lake Ronkonkoma	Nutrients
Suffolk	Long Island Sound, Suffolk County, West	Nutrients
Suffolk	Mattituck (Marratooka) Pond	Nutrients
Suffolk	Meetinghouse/Terrys Creeks and tribs	Nutrients
Suffolk	Mill and Seven Ponds	Nutrients
Suffolk	Millers Pond	Nutrients
Suffolk	Moriches Bay, East	Nutrients
Suffolk	Moriches Bay, West	Nutrients
Suffolk	Peconic River, Lower, and tidal tribs	Nutrients
Suffolk	Quantuck Bay	Nutrients
Suffolk	Shinnecock Bay and Inlet	Nutrients
Suffolk	Tidal tribs to West Moriches Bay	Nutrients
Sullivan	Bodine, Montgomery Lakes	Nutrients
Sullivan	Davies Lake	Nutrients
Sullivan	Evens Lake	Nutrients
Sullivan	Pleasure Lake	Nutrients
Tompkins	Cayuga Lake, Southern End	Nutrients
Tompkins	Cayuga Lake, Southern End	Silt/Sediment
Tompkins	Owasco Inlet, Upper, and tribs	Nutrients
Ulster	Ashokan Reservoir	Silt/Sediment
Ulster	Esopus Creek, Upper, and minor tribs	Silt/Sediment
Warren	Hague Brook and tribs	Silt/Sediment

303(d) Segments Impaired by Construction Related Pollutant(s)

Warren	Huddle/Finkle Brooks and tribs	Silt/Sediment
Warren	Indian Brook and tribs	Silt/Sediment
Warren	Lake George	Silt/Sediment
Warren	Tribs to L.George, Village of L George	Silt/Sediment
Washington	Cossayuna Lake	Nutrients
Washington	Lake Champlain, South Bay	Nutrients
Washington	Tribs to L.George, East Shore	Silt/Sediment
Washington	Wood Cr/Champlain Canal and minor tribs	Nutrients
Wayne	Port Bay	Nutrients
Westchester	Amawalk Reservoir	Nutrients
Westchester	Blind Brook, Upper, and tribs	Silt/Sediment
Westchester	Cross River Reservoir	Nutrients
Westchester	Lake Katonah	Nutrients
Westchester	Lake Lincolndale	Nutrients
Westchester	Lake Meahagh	Nutrients
Westchester	Lake Mohegan	Nutrients
Westchester	Lake Shenorock	Nutrients
Westchester	Long Island Sound, Westchester (East)	Nutrients
Westchester	Mamaroneck River, Lower	Silt/Sediment
Westchester	Mamaroneck River, Upper, and minor tribs	Silt/Sediment
Westchester	Muscoot/Upper New Croton Reservoir	Nutrients
Westchester	New Croton Reservoir	Nutrients
Westchester	Peach Lake	Nutrients
Westchester	Reservoir No.1 (Lake Isle)	Nutrients
Westchester	Saw Mill River, Lower, and tribs	Nutrients
Westchester	Saw Mill River, Middle, and tribs	Nutrients
Westchester	Sheldrake River and tribs	Silt/Sediment
Westchester	Sheldrake River and tribs	Nutrients
Westchester	Silver Lake	Nutrients
Westchester	Teatown Lake	Nutrients
Westchester	Titicus Reservoir	Nutrients
Westchester	Truesdale Lake	Nutrients
Westchester	Wallace Pond	Nutrients
Wyoming	Java Lake	Nutrients
Wyoming	Silver Lake	Nutrients

APPENDIX F – List of NYS DEC Regional Offices

<u>Region</u>	<u>COVERING THE FOLLOWING COUNTIES:</u>	<u>DIVISION OF ENVIRONMENTAL PERMITS (DEP) PERMIT ADMINISTRATORS</u>	<u>DIVISION OF WATER (DOW) WATER (SPDES) PROGRAM</u>
1	NASSAU AND SUFFOLK	50 CIRCLE ROAD STONY BROOK, NY 11790 TEL. (631) 444-0365	50 CIRCLE ROAD STONY BROOK, NY 11790-3409 TEL. (631) 444-0405
2	BRONX, KINGS, NEW YORK, QUEENS AND RICHMOND	1 HUNTERS POINT PLAZA, 47-40 21ST ST. LONG ISLAND CITY, NY 11101-5407 TEL. (718) 482-4997	1 HUNTERS POINT PLAZA, 47-40 21ST ST. LONG ISLAND CITY, NY 11101-5407 TEL. (718) 482-4933
3	DUTCHESS, ORANGE, PUTNAM, ROCKLAND, SULLIVAN, ULSTER AND WESTCHESTER	21 SOUTH PUTT CORNERS ROAD NEW PALTZ, NY 12561-1696 TEL. (845) 256-3059	100 HILLSIDE AVENUE, SUITE 1W WHITE PLAINS, NY 10603 TEL. (914) 428 - 2505
4	ALBANY, COLUMBIA, DELAWARE, GREENE, MONTGOMERY, OTSEGO, RENSSELAER, SCHENECTADY AND SCHOHARIE	1150 NORTH WESTCOTT ROAD SCHENECTADY, NY 12306-2014 TEL. (518) 357-2069	1130 NORTH WESTCOTT ROAD SCHENECTADY, NY 12306-2014 TEL. (518) 357-2045
5	CLINTON, ESSEX, FRANKLIN, FULTON, HAMILTON, SARATOGA, WARREN AND WASHINGTON	1115 STATE ROUTE 86, Po Box 296 RAY BROOK, NY 12977-0296 TEL. (518) 897-1234	232 GOLF COURSE ROAD WARRENSBURG, NY 12885-1172 TEL. (518) 623-1200
6	HERKIMER, JEFFERSON, LEWIS, ONEIDA AND ST. LAWRENCE	STATE OFFICE BUILDING 317 WASHINGTON STREET WATERTOWN, NY 13601-3787 TEL. (315) 785-2245	STATE OFFICE BUILDING 207 GENESEE STREET UTICA, NY 13501-2885 TEL. (315) 793-2554
7	BROOME, CAYUGA, CHENANGO, CORTLAND, MADISON, ONONDAGA, OSWEGO, TIOGA AND TOMPKINS	615 ERIE BLVD. WEST SYRACUSE, NY 13204-2400 TEL. (315) 426-7438	615 ERIE BLVD. WEST SYRACUSE, NY 13204-2400 TEL. (315) 426-7500
8	CHEMUNG, GENESEE, LIVINGSTON, MONROE, ONTARIO, ORLEANS, SCHUYLER, SENECA, STEUBEN, WAYNE AND YATES	6274 EAST AVON-LIMA ROADAVON, NY 14414-9519 TEL. (585) 226-2466	6274 EAST AVON-LIMA RD. AVON, NY 14414-9519 TEL. (585) 226-2466
9	ALLEGANY, CATTARAUGUS, CHAUTAUQUA, ERIE, NIAGARA AND WYOMING	270 MICHIGAN AVENUE BUFFALO, NY 14203-2999 TEL. (716) 851-7165	270 MICHIGAN AVENUE BUFFALO, NY 14203-2999 TEL. (716) 851-7070

Appendix C

Notice of Intent (eNOI)

NOI for coverage under Stormwater General Permit for Construction Activity

version 1.30

(Submission #: HP8-VR76-YYJH4, version 1)

Details

Originally Started By Richard Haight

Submission ID HP8-VR76-YYJH4

Submission Reason New

Status Draft

Form Input

Owner/Operator Information

Owner/Operator Name (Company/Private Owner/Municipality/Agency/Institution, etc.)

Plug Power

Owner/Operator Contact Person Last Name (NOT CONSULTANT)

Brophy

Owner/Operator Contact Person First Name

Brenor

Owner/Operator Mailing Address

968 Albany Shaker Road

City

Latham

State

New York

Zip

12110

Phone

408 823-6566

Email

brbrophy@plugpower.com

Federal Tax ID

22-3672377

Project Location**Project/Site Name**

Plug Power Hydrogen Production Facility

Street Address (Not P.O. Box)

6840 Crosby Road

Side of Street

West

City/Town/Village (THAT ISSUES BUILDING PERMIT)

Alabama

State

NY

Zip

14013

DEC Region

8

County

GENESEE

Name of Nearest Cross Street

STAMP Drive

Distance to Nearest Cross Street (Feet)

1435

Project In Relation to Cross Street

South

Tax Map Numbers Section-Block-Parcel

10-1-42

Tax Map Numbers

NONE PROVIDED

1. Coordinates

Provide the Geographic Coordinates for the project site. The two methods are:

- Navigate to the project location on the map (below) and click to place a marker and obtain the XY coordinates.

- The "Find Me" button will provide the lat/long for the person filling out this form. Then pan the map to the correct location and click the map to place a marker and obtain the XY coordinates.

Navigate to your location and click on the map to get the X,Y coordinates

43.082739642240895,-78.40548446174046

Project Details

2. What is the nature of this project?

New Construction

3. Select the predominant land use for both pre and post development conditions.

Pre-Development Existing Landuse

Cultivated Land

Post-Development Future Land Use

Industrial

3a. If Single Family Subdivision was selected in question 3, enter the number of subdivision lots.

NONE PROVIDED

4. In accordance with the larger common plan of development or sale, enter the total project site acreage, the acreage to be disturbed and the future impervious area (acreage)within the disturbed area.

*** ROUND TO THE NEAREST TENTH OF AN ACRE. ***

Total Site Area (acres)

29.1

Total Area to be Disturbed (acres)

27.0

Existing Impervious Area to be Disturbed (acres)

0.3

Future Impervious Area Within Disturbed Area (acres)

15.5

5. Do you plan to disturb more than 5 acres of soil at any one time?

Yes

6. Indicate the percentage (%) of each Hydrologic Soil Group(HSG) at the site.

A (%)

0

B (%)

0

C (%)

0

D (%)

100

7. Is this a phased project?

Yes

8. Enter the planned start and end dates of the disturbance activities.

Start Date

9/1/2021

End Date

12/31/2023

9. Identify the nearest surface waterbody(ies) to which construction site runoff will discharge.

Un-named Tributary Wetland

9a. Type of waterbody identified in question 9?

Wetland/Federal Jurisdiction On Site (Answer 9b)

Other Waterbody Type Off Site Description

NONE PROVIDED

9b. If "wetland" was selected in 9A, how was the wetland identified?

Delineated by Consultant

10. Has the surface waterbody(ies) in question 9 been identified as a 303(d) segment in Appendix E of GP-0-20-001?

No

11. Is this project located in one of the Watersheds identified in Appendix C of GP-0-20-001?

No

12. Is the project located in one of the watershed areas associated with AA and AA-S classified waters?

No

If No, skip question 13.

13. Does this construction activity disturb land with no existing impervious cover and where the Soil Slope Phase is identified as an E or F on the USDA Soil Survey?

No

If Yes, what is the acreage to be disturbed?

NONE PROVIDED

14. Will the project disturb soils within a State regulated wetland or the protected 100 foot adjacent area?

No

15. Does the site runoff enter a separate storm sewer system (including roadside drains, swales, ditches, culverts, etc)?

Yes

16. What is the name of the municipality/entity that owns the separate storm sewer system?

Town of Alabama

17. Does any runoff from the site enter a sewer classified as a Combined Sewer?

No

18. Will future use of this site be an agricultural property as defined by the NYS Agriculture and Markets Law?

No

19. Is this property owned by a state authority, state agency, federal government or local government?

No

20. Is this a remediation project being done under a Department approved work plan? (i.e. CERCLA, RCRA, Voluntary Cleanup Agreement, etc.)

No

Required SWPPP Components

21. Has the required Erosion and Sediment Control component of the SWPPP been developed in conformance with the current NYS Standards and Specifications for Erosion and Sediment Control (aka Blue Book)?

Yes

22. Does this construction activity require the development of a SWPPP that includes the post-construction stormwater management practice component (i.e. Runoff Reduction, Water Quality and Quantity Control practices/techniques)?

Yes

If you answered No in question 22, skip question 23 and the Post-construction Criteria and Post-construction SMP Identification sections.

23. Has the post-construction stormwater management practice component of the SWPPP been developed in conformance with the current NYS Stormwater Management Design Manual?

Yes

24. The Stormwater Pollution Prevention Plan (SWPPP) was prepared by:
Professional Engineer (P.E.)

SWPPP Preparer

Richard J. Haight, P.E. - Invictus Civil Engineering, P.C.

Contact Name (Last, Space, First)

Haight, Richard

Mailing Address

4759 N 5TH ST

City

LEWISTON

State

NY

Zip

14092

Phone

17169462415

Email

rhaight@invictuscivilengineering.com

Download SWPPP Preparer Certification Form

Please take the following steps to prepare and upload your preparer certification form:

- 1) Click on the link below to download a blank certification form
- 2) The certified SWPPP preparer should sign this form

3) Scan the signed form

4) Upload the scanned document

[Download SWPPP Preparer Certification Form](#)

Please upload the SWPPP Preparer Certification

Plug Power SWPPP Preparer Signature Form.pdf - 05/20/2021 04:24 PM

Comment

NONE PROVIDED

Erosion & Sediment Control Criteria

25. Has a construction sequence schedule for the planned management practices been prepared?

Yes

26. Select all of the erosion and sediment control practices that will be employed on the project site:

Temporary Structural

Check Dams

Dust Control

Silt Fence

Stabilized Construction Entrance

Storm Drain Inlet Protection

Biotechnical

None

Vegetative Measures

Protecting Vegetation

Seeding

Topsoiling

Mulching

Permanent Structural

Rock Outlet Protection

Other

NONE PROVIDED

Post-Construction Criteria

*** IMPORTANT: Completion of Questions 27-39 is not required if response to Question 22 is No.**

27. Identify all site planning practices that were used to prepare the final site plan/layout for the project.

Preservation of Buffers

Locating Development in Less Sensitive Areas

27a. Indicate which of the following soil restoration criteria was used to address the requirements in Section 5.1.6("Soil Restoration") of the Design Manual (2010 version).

All disturbed areas will be restored in accordance with the Soil Restoration requirements in Table 5.3 of the Design Manual (see page 5-22).

28. Provide the total Water Quality Volume (WQv) required for this project (based on final site plan/layout). (Acre-feet)

1.267

29. Post-construction SMP Identification

Use the Post-construction SMP Identification section to identify the RR techniques (Area Reduction), RR techniques(Volume Reduction) and Standard SMPs with RRv Capacity that were used to reduce the Total WQv Required (#28).

Identify the SMPs to be used by providing the total impervious area that contributes runoff to each technique/practice selected. For the Area Reduction Techniques, provide the total contributing area (includes pervious area) and, if applicable, the total impervious area that contributes runoff to the technique/practice.

Note: Redevelopment projects shall use the Post-Construction SMP Identification section to identify the SMPs used to treat and/or reduce the WQv required. If runoff reduction techniques will not be used to reduce the required WQv, skip to question 33a after identifying the SMPs.

30. Indicate the Total RRv provided by the RR techniques (Area/Volume Reduction) and Standard SMPs with RRv capacity identified in question 29. (acre-feet)

0.508

31. Is the Total RRv provided (#30) greater than or equal to the total WQv required (#28)?

No

If Yes, go to question 36. If No, go to question 32.

32. Provide the Minimum RRv required based on HSG. [Minimum RRv Required = (P) (0.95) (Ai) / 12, Ai=(s) (Aic)] (acre-feet)

0.241

32a. Is the Total RRv provided (#30) greater than or equal to the Minimum RRv Required (#32)?

Yes

If Yes, go to question 33.

Note: Use the space provided in question #39 to summarize the specific site limitations and justification for not reducing 100% of WQv required (#28). A detailed evaluation of the specific site limitations and justification for not reducing 100% of the WQv required (#28) must also be included in the SWPPP.

If No, sizing criteria has not been met; therefore, NOI can not be processed. SWPPP preparer must modify design to meet sizing criteria.

33. SMPs

Use the Post-construction SMP Identification section to identify the Standard SMPs and, if applicable, the Alternative SMPs to be used to treat the remaining total WQv (=Total WQv Required in #28 - Total RRv Provided in #30).

Also, provide the total impervious area that contributes runoff to each practice selected.

NOTE: Use the Post-construction SMP Identification section to identify the SMPs used on Redevelopment projects.

33a. Indicate the Total WQv provided (i.e. WQv treated) by the SMPs identified in question #33 and Standard SMPs with RRv Capacity identified in question #29. (acre-feet)

0.762

Note: For the standard SMPs with RRv capacity, the WQv provided by each practice = the WQv calculated using the contributing drainage area to the practice - provided by the practice. (See Table 3.5 in Design Manual)

34. Provide the sum of the Total RRv provided (#30) and the WQv provided (#33a).

1.270

35. Is the sum of the RRv provided (#30) and the WQv provided (#33a) greater than or equal to the total WQv required (#28)?

Yes

If Yes, go to question 36.

If No, sizing criteria has not been met; therefore, NOI can not be processed. SWPPP preparer must modify design to meet sizing criteria.

36. Provide the total Channel Protection Storage Volume (CPv required and provided or select waiver (#36a), if applicable.

CPv Required (acre-feet)

0.741

CPv Provided (acre-feet)

1.214

36a. The need to provide channel protection has been waived because:

NONE PROVIDED

37. Provide the Overbank Flood (Qp) and Extreme Flood (Qf) control criteria or select waiver (#37a), if applicable.

Overbank Flood Control Criteria (Qp)

Pre-Development (CFS)

26.71

Post-Development (CFS)

13.50

Total Extreme Flood Control Criteria (Qf)

Pre-Development (CFS)

58.95

Post-Development (CFS)

34.12

37a. The need to meet the Qp and Qf criteria has been waived because:

NONE PROVIDED

38. Has a long term Operation and Maintenance Plan for the post-construction stormwater management practice(s) been developed?

Yes

If Yes, Identify the entity responsible for the long term Operation and Maintenance
Plug Power

39. Use this space to summarize the specific site limitations and justification for not reducing 100% of WQv required (#28). (See question #32a) This space can also be used for other pertinent project information.

The site limitations for not reducing 100% of the WQv are soils with an infiltration rate less than 0.5 inches/hour.

Post-Construction SMP Identification

Runoff Reduction (RR) Techniques, Standard Stormwater Management Practices (SMPs) and Alternative SMPs

Identify the Post-construction SMPs to be used by providing the total impervious area that contributes runoff to each technique/practice selected. For the Area Reduction Techniques, provide the total contributing area (includes pervious area) and, if applicable, the total impervious area that contributes runoff to the technique/practice.

RR Techniques (Area Reduction)

Round to the nearest tenth

Total Contributing Acres for Conservation of Natural Area (RR-1)
NONE PROVIDED

Total Contributing Impervious Acres for Conservation of Natural Area (RR-1)
0.000

Total Contributing Acres for Sheetflow to Riparian Buffers/Filter Strips (RR-2)
4.083

Total Contributing Impervious Acres for Sheetflow to Riparian Buffers/Filter Strips (RR-2)
0.000

Total Contributing Acres for Tree Planting/Tree Pit (RR-3)
0.000

Total Contributing Impervious Acres for Tree Planting/Tree Pit (RR-3)
0.000

Total Contributing Acres for Disconnection of Rooftop Runoff (RR-4)
0.000

RR Techniques (Volume Reduction)

Total Contributing Impervious Acres for Disconnection of Rooftop Runoff (RR-4)
0.000

Total Contributing Impervious Acres for Vegetated Swale (RR-5)
0.000

Total Contributing Impervious Acres for Rain Garden (RR-6)
0.000

Total Contributing Impervious Acres for Stormwater Planter (RR-7)
0.000

Total Contributing Impervious Acres for Rain Barrel/Cistern (RR-8)
0.000

Total Contributing Impervious Acres for Porous Pavement (RR-9)
0.000

Total Contributing Impervious Acres for Green Roof (RR-10)
0.000

Standard SMPs with RRv Capacity

Total Contributing Impervious Acres for Infiltration Trench (I-1)

0.000

Total Contributing Impervious Acres for Infiltration Basin (I-2)

0.000

Total Contributing Impervious Acres for Dry Well (I-3)

0.000

Total Contributing Impervious Acres for Underground Infiltration System (I-4)

0.000

Total Contributing Impervious Acres for Bioretention (F-5)

15.513

Total Contributing Impervious Acres for Dry Swale (O-1)

0.000

Standard SMPs

Total Contributing Impervious Acres for Micropool Extended Detention (P-1)

0.000

Total Contributing Impervious Acres for Wet Pond (P-2)

0.000

Total Contributing Impervious Acres for Wet Extended Detention (P-3)

0.000

Total Contributing Impervious Acres for Multiple Pond System (P-4)

0.000

Total Contributing Impervious Acres for Pocket Pond (P-5)

0.000

Total Contributing Impervious Acres for Surface Sand Filter (F-1)

0.000

Total Contributing Impervious Acres for Underground Sand Filter (F-2)

0.000

Total Contributing Impervious Acres for Perimeter Sand Filter (F-3)

0.000

Total Contributing Impervious Acres for Organic Filter (F-4)

0.000

Total Contributing Impervious Acres for Shallow Wetland (W-1)

0.000

Total Contributing Impervious Acres for Extended Detention Wetland (W-2)
0.000

Total Contributing Impervious Acres for Pond/Wetland System (W-3)
0.000

Total Contributing Impervious Acres for Pocket Wetland (W-4)
0.000

Total Contributing Impervious Acres for Wet Swale (O-2)
0.000

**Alternative SMPs (DO NOT INCLUDE PRACTICES BEING USED FOR
PRETREATMENT ONLY)**

Total Contributing Impervious Area for Hydrodynamic
0.000

Total Contributing Impervious Area for Wet Vault
0.000

Total Contributing Impervious Area for Media Filter
0.000

"Other" Alternative SMP?
0.000

Total Contributing Impervious Area for "Other"
0.000

Provide the name and manufacturer of the alternative SMPs (i.e. proprietary practice(s)) being used for WQv treatment.

Note: Redevelopment projects which do not use RR techniques, shall use questions 28, 29, 33 and 33a to provide SMPs used, total WQv required and total WQv provided for the project.

Manufacturer of Alternative SMP
NONE PROVIDED

Name of Alternative SMP
NONE PROVIDED

Other Permits

40. Identify other DEC permits, existing and new, that are required for this project/facility.

None

If SPDES Multi-Sector GP, then give permit ID

NONE PROVIDED

If Other, then identify

NONE PROVIDED

41. Does this project require a US Army Corps of Engineers Wetland Permit?

No

If "Yes," then indicate Size of Impact, in acres, to the nearest tenth

NONE PROVIDED

42. If this NOI is being submitted for the purpose of continuing or transferring coverage under a general permit for stormwater runoff from construction activities, please indicate the former SPDES number assigned.

NONE PROVIDED

MS4 SWPPP Acceptance

43. Is this project subject to the requirements of a regulated, traditional land use control MS4?

No

If No, skip question 44

44. Has the "MS4 SWPPP Acceptance" form been signed by the principal executive officer or ranking elected official and submitted along with this NOI?

NONE PROVIDED

MS4 SWPPP Acceptance Form Download

Download form from the link below. Complete, sign, and upload.

[MS4 SWPPP Acceptance Form](#)

MS4 Acceptance Form Upload

NONE PROVIDED

Comment

NONE PROVIDED

Owner/Operator Certification

Owner/Operator Certification Form Download

Download the certification form by clicking the link below. Complete, sign, scan, and upload the form.

[Owner/Operator Certification Form \(PDF, 45KB\)](#)

Upload Owner/Operator Certification Form

NONE PROVIDED

Comment

NONE PROVIDED

Attachments

Date	Attachment Name	Context	User
5/20/2021 4:24 PM	Plug Power SWPPP Preparer Signature Form.pdf	Attachment	Richard Haight

Appendix D

Notice of Termination (NOT) Form

**New York State Department of Environmental Conservation
Division of Water
625 Broadway, 4th Floor
Albany, New York 12233-3505**

(NOTE: Submit completed form to address above)

**NOTICE OF TERMINATION for Storm Water Discharges Authorized
under the SPDES General Permit for Construction Activity**

Please indicate your permit identification number: NYR _____

I. Owner or Operator Information

1. Owner/Operator Name:

2. Street Address:

3. City/State/Zip:

4. Contact Person:

4a. Telephone:

4b. Contact Person E-Mail:

II. Project Site Information

5. Project/Site Name:

6. Street Address:

7. City/Zip:

8. County:

III. Reason for Termination

9a. All disturbed areas have achieved final stabilization in accordance with the general permit and SWPPP. *Date final stabilization completed (month/year): _____

9b. Permit coverage has been transferred to new owner/operator. Indicate new owner/operator's permit identification number: NYR _____
(Note: Permit coverage can not be terminated by owner identified in I.1. above until new owner/operator obtains coverage under the general permit)

9c. Other (Explain on Page 2)

IV. Final Site Information:

10a. Did this construction activity require the development of a SWPPP that includes post-construction stormwater management practices? yes no (If no, go to question 10f.)

10b. Have all post-construction stormwater management practices included in the final SWPPP been constructed? yes no (If no, explain on Page 2)

10c. Identify the entity responsible for long-term operation and maintenance of practice(s)?

**NOTICE OF TERMINATION for Storm Water Discharges Authorized under the
SPDES General Permit for Construction Activity - continued**

10d. Has the entity responsible for long-term operation and maintenance been given a copy of the operation and maintenance plan required by the general permit? yes no

10e. Indicate the method used to ensure long-term operation and maintenance of the post-construction stormwater management practice(s):

- Post-construction stormwater management practice(s) and any right-of-way(s) needed to maintain practice(s) have been deeded to the municipality.
- Executed maintenance agreement is in place with the municipality that will maintain the post-construction stormwater management practice(s).
- For post-construction stormwater management practices that are privately owned, a mechanism is in place that requires operation and maintenance of the practice(s) in accordance with the operation and maintenance plan, such as a deed covenant in the owner or operator's deed of record.
- For post-construction stormwater management practices that are owned by a public or private institution (e.g. school, university or hospital), government agency or authority, or public utility; policy and procedures are in place that ensures operation and maintenance of the practice(s) in accordance with the operation and maintenance plan.

10f. Provide the total area of impervious surface (i.e. roof, pavement, concrete, gravel, etc.) constructed within the disturbance area? _____
(acres)

11. Is this project subject to the requirements of a regulated, traditional land use control MS4? yes
 no
(If Yes, complete section VI - "MS4 Acceptance" statement

V. Additional Information/Explanation:
(Use this section to answer questions 9c. and 10b., if applicable)

VI. MS4 Acceptance - MS4 Official (principal executive officer or ranking elected official) or Duly Authorized Representative (Note: Not required when 9b. is checked -transfer of coverage)

I have determined that it is acceptable for the owner or operator of the construction project identified in question 5 to submit the Notice of Termination at this time.

Printed Name:

Title/Position:

Signature:

Date:

**NOTICE OF TERMINATION for Storm Water Discharges Authorized under the
SPDES General Permit for Construction Activity - continued**

VII. Qualified Inspector Certification - Final Stabilization:

I hereby certify that all disturbed areas have achieved final stabilization as defined in the current version of the general permit, and that all temporary, structural erosion and sediment control measures have been removed. Furthermore, I understand that certifying false, incorrect or inaccurate information is a violation of the referenced permit and the laws of the State of New York and could subject me to criminal, civil and/or administrative proceedings.

Printed Name:

Title/Position:

Signature:

Date:

VIII. Qualified Inspector Certification - Post-construction Stormwater Management Practice(s):

I hereby certify that all post-construction stormwater management practices have been constructed in conformance with the SWPPP. Furthermore, I understand that certifying false, incorrect or inaccurate information is a violation of the referenced permit and the laws of the State of New York and could subject me to criminal, civil and/or administrative proceedings.

Printed Name:

Title/Position:

Signature:

Date:

IX. Owner or Operator Certification

I hereby certify that this document was prepared by me or under my direction or supervision. My determination, based upon my inquiry of the person(s) who managed the construction activity, or those persons directly responsible for gathering the information, is that the information provided in this document is true, accurate and complete. Furthermore, I understand that certifying false, incorrect or inaccurate information is a violation of the referenced permit and the laws of the State of New York and could subject me to criminal, civil and/or administrative proceedings.

Printed Name:

Title/Position:

Signature:

Date:

Appendix E

Contractor Certification Forms

CONTRACTOR'S CERTIFICATION STATEMENT

All contractors that will be responsible for installing, constructing, repairing, inspecting and maintaining the erosion and sediment control practices included in the SWPPP; and the contractors that will be responsible for the construction of all post-construction storm water management practices included in the SWPPP must sign the following certification statement before commencing any construction activity.

"I hereby certify under penalty of law that I understand and agree to comply with the terms and conditions of the SWPPP and agree to implement any corrective actions identified by the *qualified inspector* during a site inspection. I also understand that the *owner or operator* must comply with the terms and conditions of the most current version of the New York State Pollutant Discharge Elimination System ("SPDES") general permit for stormwater *discharges from construction activities* and that it is unlawful for any person to cause or contribute to a violation of *water quality standards*. Furthermore, I am aware that there are significant penalties for submitting false information, that I do not believe to be true, including the possibility of fine and imprisonment for knowing violations"

Site Location: _____

Name: _____

Company: _____ Title: _____

Company Address: _____

Company Telephone: _____ Fax: _____

Signature: _____ Date: _____

Elements of SWPPP responsible for: _____

Trained Individual Responsible for Implementation: _____

Title: _____

SUBCONTRACTOR'S CERTIFICATION STATEMENT

All subcontractors that will be responsible for installing, constructing, repairing, inspecting and maintaining the erosion and sediment control practices included in the SWPPP; and the subcontractors that will be responsible for the construction of all post-construction storm water management practices included in the SWPPP must sign the following certification statement before commencing any construction activity.

"I hereby certify under penalty of law that I understand and agree to comply with the terms and conditions of the SWPPP and agree to implement any corrective actions identified by the *qualified inspector* during a site inspection. I also understand that the *owner or operator* must comply with the terms and conditions of the most current version of the New York State Pollutant Discharge Elimination System ("SPDES") general permit for stormwater *discharges from construction activities* and that it is unlawful for any person to cause or contribute to a violation of *water quality standards*. Furthermore, I am aware that there are significant penalties for submitting false information, that I do not believe to be true, including the possibility of fine and imprisonment for knowing violations"

Site Location: _____

Name: _____

Company: _____ **Title:** _____

Company Address: _____

Company Telephone: _____ **Fax:** _____

Signature: _____ **Date:** _____

Elements of SWPPP responsible for: _____

Trained Individual Responsible for Implementation: _____

Title: _____

Appendix F

NYSDEC Phase II SPDES Letter (folder for insert)

Appendix G

Soil Erosion & Sediment Control Details and Specifications

STANDARD AND SPECIFICATIONS FOR TEMPORARY CONSTRUCTION AREA SEEDING



Definition & Scope

Providing temporary erosion control protection to disturbed areas and/or localized critical areas for an interim period by covering all bare ground that exists as a result of construction activities or a natural event. Critical areas may include but are not limited to steep excavated cut or fill slopes and any disturbed, denuded natural slopes subject to erosion.

Conditions Where Practice Applies

Temporary seedings may be necessary on construction sites to protect an area, or section, where final grading is complete, when preparing for winter work shutdown, or to provide cover when permanent seedings are likely to fail due to mid-summer heat and drought. The intent is to provide temporary protective cover during temporary shutdown of construction and/or while waiting for optimal planting time.

Criteria

Water management practices must be installed as appropriate for site conditions. The area must be rough graded and slopes physically stable. Large debris and rocks are usually removed. Seedbed must be seeded within 24 hours of disturbance or scarification of the soil surface will be necessary prior to seeding.

Fertilizer or lime are not typically used for temporary seedings.

IF: Spring or summer or early fall, then seed the area with ryegrass (annual or perennial) at 30 lbs. per acre (Approximately 0.7 lb./1000 sq. ft. or use 1 lb./1000 sq. ft.).

IF: Late fall or early winter, then seed Certified 'Aroostook' winter rye (cereal rye) at 100 lbs. per acre (2.5 lbs./1000 sq. ft.).

Any seeding method may be used that will provide uniform application of seed to the area and result in relatively good soil to seed contact.

Mulch the area with hay or straw at 2 tons/acre (approx. 90 lbs./1000 sq. ft. or 2 bales). Quality of hay or straw mulch allowable will be determined based on long term use and visual concerns. Mulch anchoring will be required where wind or areas of concentrated water are of concern. Wood fiber hydromulch or other sprayable products approved for erosion control (nylon web or mesh) may be used if applied according to manufacturers' specification. Caution is advised when using nylon or other synthetic products. They may be difficult to remove prior to final seeding and can be a hazard to young wildlife species.

STANDARD AND SPECIFICATIONS FOR PERMANENT CONSTRUCTION AREA PLANTING



Definition & Scope

Establishing **permanent** grasses with other forbs and/or shrubs to provide a minimum 80% perennial vegetative cover on areas disturbed by construction and critical areas to reduce erosion and sediment transport. Critical areas may include but are not limited to steep excavated cut or fill slopes as well as eroding or denuded natural slopes and areas subject to erosion.

Conditions Where Practice Applies

This practice applies to all disturbed areas void of, or having insufficient, cover to prevent erosion and sediment transport. See additional standards for special situations such as sand dunes and sand and gravel pits.

Criteria

All water control measures will be installed as needed prior to final grading and seedbed preparation. Any severely compacted sections will require chiseling or disking to provide an adequate rooting zone, to a minimum depth of 12", see Soil Restoration Standard. The seedbed must be prepared to allow good soil to seed contact, with the soil not too soft and not too compact. Adequate soil moisture must be present to accomplish this. If surface is powder dry or sticky wet, postpone operations until moisture changes to a favorable condition. If seeding is accomplished within 24 hours of final grading, additional scarification is generally not needed, especially on ditch or stream banks. Remove all stones and other debris from the surface that are greater than 4 inches, or that will interfere with future mowing or maintenance.

Soil amendments should be incorporated into the upper 2 inches of soil when feasible. **The soil should be tested to determine the amounts of amendments needed.** Apply

ground agricultural limestone to attain a pH of 6.0 in the upper 2 inches of soil. If soil must be fertilized before results of a soil test can be obtained to determine fertilizer needs, apply commercial fertilizer at 600 lbs. per acre of 5-5-10 or equivalent. If manure is used, apply a quantity to meet the nutrients of the above fertilizer. This requires an appropriate manure analysis prior to applying to the site. Do not use manure on sites to be planted with birdsfoot trefoil or in the path of concentrated water flow.

Seed mixtures may vary depending on location within the state and time of seeding. Generally, warm season grasses should only be seeded during early spring, April to May. These grasses are primarily used for vegetating excessively drained sands and gravels. See Standard and Specification for Sand and Gravel Mine Reclamation. Other grasses may be seeded any time of the year when the soil is not frozen and is workable. When legumes such as birdsfoot trefoil are included, spring seeding is preferred. See Table 4.4, "Permanent Construction Area Planting Mixture Recommendations" for additional seed mixtures.

<u>General Seed Mix:</u>			
	Variety	lbs./acre	lbs/1000 sq. ft.
Red Clover ¹ <u>OR</u>	Acclaim, Rally, Red Head II, Renegade	8 ²	0.20
Common white clover ¹	Common	8	0.20
<u>PLUS</u>			
Creeping Red Fescue	Common	20	0.45
<u>PLUS</u>			
Smooth Bromegrass <u>OR</u>	Common	2	0.05
Ryegrass (perennial)	Pennfine/Linn	5	0.10
¹ add inoculant immediately prior to seeding ² Mix 4 lbs each of Empire and Pardee OR 4 lbs of Birdsfoot and 4 lbs white clover per acre. All seeding rates are given for Pure Live Seed (PLS)			

Pure Live Seed, or (PLS) refers to the amount of live seed in a lot of bulk seed. Information on the seed bag label includes the type of seed, supplier, test date, source of seed, purity, and germination. Purity is the percentage of pure seed. Germination is the percentage of pure seed that will produce normal plants when planted under favorable conditions.

To compute Pure Live Seed multiply the “germination percent” times the “purity” and divide that by 100 to get Pure Live Seed.

$$\text{Pure Live Seed (PLS)} = \frac{\% \text{ Germination} \times \% \text{ Purity}}{100}$$

For example, the PLS for a lot of Kentucky Blue grass with 75% purity and 96% germination would be calculated as follows:

$$\frac{(96) \times (75)}{100} = 72\% \text{ Pure Live Seed}$$

For 10lbs of PLS from this lot =

$$\frac{10}{0.72} = 13.9 \text{ lbs}$$

Therefore, 13.9 lbs of seed is the actual weight needed to meet 10lbs PSL from this specific seed lot.

Time of Seeding: The optimum timing for the general seed mixture is early spring. Permanent seedings may be made any time of year if properly mulched and adequate moisture is provided. Late June through early August is not a good time to seed, but may facilitate covering the land without additional disturbance if construction is completed. Portions of the seeding may fail due to drought and heat. These areas may need reseeding in late summer/fall or the following spring.

Method of seeding: Broadcasting, drilling, cultipack type seeding, or hydroseeding are acceptable methods. Proper soil to seed contact is key to successful seedings.

Mulching: Mulching is essential to obtain a uniform stand of seeded plants. Optimum benefits of mulching new seedings are obtained with the use of small grain straw applied at a rate of 2 tons per acre, and anchored with a netting or tackifier. See the Standard and Specifications for Mulching for choices and requirements.

Irrigation: Watering may be essential to establish a new seeding when a drought condition occurs shortly after a new seeding emerges. Irrigation is a specialized practice and care must be taken not to exceed the application rate for the soil or subsoil. When disconnecting irrigation pipe, be sure pipes are drained in a safe manor, not creating an erosion concern.



80% Perennial Vegetative Cover



50% Perennial Vegetative Cover

**Table 4.4
Permanent Construction Area Planting Mixture Recommendations**

Seed Mixture	Variety	Rate in lbs./acre (PLS)	Rate in lbs./1,000 ft ²
Mix #1			
Creeping red fescue	Ensylva, Pennlawn, Boreal	10	.25
Perennial ryegrass	Pennfine, Linn	10	.25
*This mix is used extensively for shaded areas.			
Mix #2			
Switchgrass	Shelter, Pathfinder, Trailblazer, or Blackwell	20	.50
*This rate is in pure live seed, this would be an excellent choice along the upland edge of a wetland to filter runoff and provide wildlife benefits. In areas where erosion may be a problem, a companion seeding of sand lovegrass should be added to provide quick cover at a rate of 2 lbs. per acre (0.05 lbs. per 1000 sq. ft.).			
Mix #3			
Switchgrass	Shelter, Pathfinder, Trailblazer, or Blackwell	4	.10
Big bluestem	Niagara	4	.10
Little bluestem	Aldous or Camper	2	.05
Indiangrass	Rumsey	4	.10
Coastal panicgrass	Atlantic	2	.05
Sideoats grama	El Reno or Trailway	2	.05
Wildflower mix		.50	.01
*This mix has been successful on sand and gravel plantings. It is very difficult to seed without a warm season grass seeder such as a Truax seed drill. Broadcasting this seed is very difficult due to the fluffy nature of some of the seed, such as bluestems and indiangrass.			
Mix #4			
Switchgrass	Shelter, Pathfinder, Trailblazer, or Blackwell	10	.25
Coastal panicgrass	Atlantic	10	.25
*This mix is salt tolerant, a good choice along the upland edge of tidal areas and roadsides.			
Mix #5			
Saltmeadow cordgrass (<i>Spartina patens</i>)—This grass is used for tidal shoreline protection and tidal marsh restoration. It is planted by vegetative stem divisions.			
'Cape' American beachgrass can be planted for sand dune stabilization above the saltmeadow cordgrass zone.			
Mix #6			
Creeping red fescue	Ensylva, Pennlawn, Boreal	20	.45
Chewings Fescue	Common	20	.45
Perennial ryegrass	Pennfine, Linn	5	.10
Red Clover	Common	10	.45
*General purpose erosion control mix. Not to be used for a turf planting or play grounds.			

STANDARD AND SPECIFICATIONS FOR STABILIZED CONSTRUCTION ACCESS



Definition & Scope

A stabilized pad of aggregate underlain with geotextile located at any point where traffic will be entering or leaving a construction site to or from a public right-of-way, street, alley, sidewalk, or parking area. The purpose of stabilized construction access is to reduce or eliminate the tracking of sediment onto public rights-of-way or streets.

Conditions Where Practice Applies

A stabilized construction access shall be used at all points of construction ingress and egress.

Design Criteria

See Figure 2.1 on page 2.31 for details.

Aggregate Size: Use a matrix of 1-4 inch stone, or reclaimed or recycled concrete equivalent.

Thickness: Not less than six (6) inches.

Width: 12-foot minimum but not less than the full width of points where ingress or egress occurs. 24-foot minimum if there is only one access to the site.

Length: As required, but not less than 50 feet (except on a single residence lot where a 30 foot minimum would apply).

Geotextile: To be placed over the entire area to be covered with aggregate. Filter cloth will not be required on a single-family residence lot. Piping of surface water under entrance shall be provided as required. If piping is impossible, a mountable berm with 5:1 slopes will be permitted.

Criteria for Geotextile: The geotextile shall be woven or nonwoven fabric consisting only of continuous chain polymeric filaments or yarns of polyester. The fabric shall be

inert to commonly encountered chemicals, hydro-carbons, mildew, rot resistant, and conform to the fabric properties as shown:

Fabric Properties ³	Light Duty ¹ Roads Grade Sub- grade	Heavy Duty ² Haul Roads Rough Graded	Test Method
Grab Tensile Strength (lbs)	200	220	ASTM D1682
Elongation at Failure (%)	50	60	ASTM D1682
Mullen Burst Strength (lbs)	190	430	ASTM D3786
Puncture Strength (lbs)	40	125	ASTM D751 Modified
Equivalent	40-80	40-80	US Std Sieve
Opening Size			CW-02215
Aggregate Depth	6	10	-

¹Light Duty Road: Area sites that have been graded to subgrade and where most travel would be single axle vehicles and an occasional multi-axle truck. Acceptable materials are Trevira Spunbond 1115, Mirafi 100X, Typar 3401, or equivalent.

²Heavy Duty Road: Area sites with only rough grading, and where most travel would be multi-axle vehicles. Acceptable materials are Trevira Spunbond 1135, Mirafi 600X, or equivalent.

³Fabrics not meeting these specifications may be used only when design procedure and supporting documentation are supplied to determine aggregate depth and fabric strength.

Maintenance

The access shall be maintained in a condition which will prevent tracking of sediment onto public rights-of-way or streets. This may require periodic top dressing with additional aggregate. All sediment spilled, dropped, or washed onto public rights-of-way must be removed immediately.

When necessary, wheels must be cleaned to remove sediment prior to entrance onto public rights-of-way. When washing is required, it shall be done on an area stabilized with aggregate, which drains into an approved sediment-trapping device. All sediment shall be prevented from entering storm drains, ditches, or watercourses.

**Figure 2.1
Stabilized Construction Access**

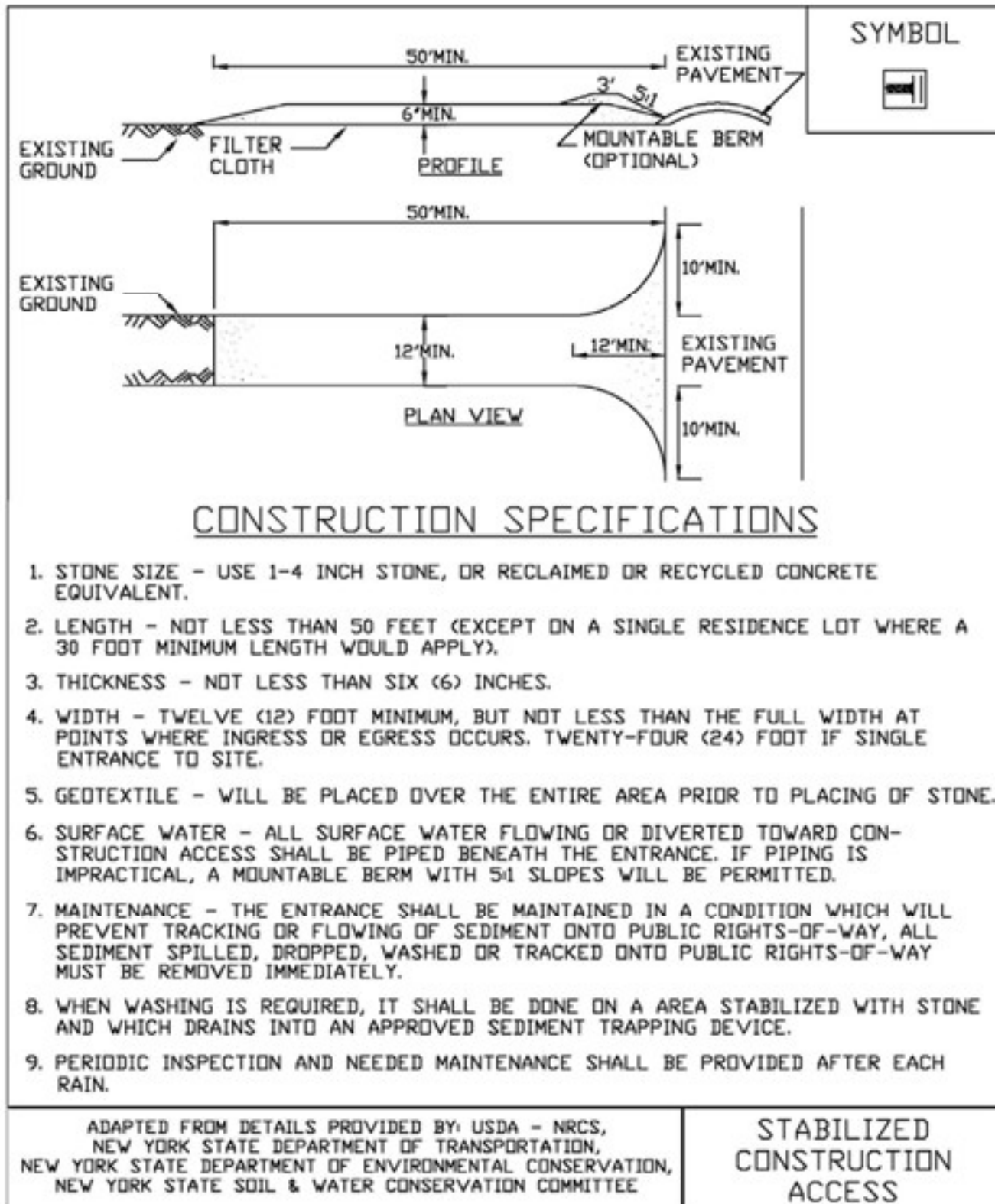

STANDARD AND SPECIFICATIONS FOR SILT FENCE



Definition & Scope

A **temporary** barrier of geotextile fabric installed on the contours across a slope used to intercept sediment laden runoff from small drainage areas of disturbed soil by temporarily ponding the sediment laden runoff allowing settling to occur. The maximum period of use is limited by the ultraviolet stability of the fabric (approximately one year).

Conditions Where Practice Applies

A silt fence may be used subject to the following conditions:

1. Maximum allowable slope length and fence length will not exceed the limits shown in the Design Criteria for the specific type of silt fence used ; and
2. Maximum ponding depth of 1.5 feet behind the fence; and
3. Erosion would occur in the form of sheet erosion; and
4. There is no concentration of water flowing to the barrier; and
5. Soil conditions allow for proper keying of fabric, or other anchorage, to prevent blowouts.

Design Criteria

1. Design computations are not required for installations of 1 month or less. Longer installation periods should be designed for expected runoff.
2. All silt fences shall be placed as close to the disturbed area as possible, but at least 10 feet from the toe of a slope steeper than 3H:1V, to allow for maintenance and

roll down. The area beyond the fence must be undisturbed or stabilized.

3. The type of silt fence specified for each location on the plan shall not exceed the maximum slope length and maximum fence length requirements shown in the following table:

		Slope Length/Fence Length (ft.)		
Slope	Steepness	Standard	Reinforced	Super
<2%	< 50:1	300/1500	N/A	N/A
2-10%	50:1 to 10:1	125/1000	250/2000	300/2500
10-20%	10:1 to 5:1	100/750	150/1000	200/1000
20-33%	5:1 to 3:1	60/500	80/750	100/1000
33-50%	3:1 to 2:1	40/250	70/350	100/500
>50%	> 2:1	20/125	30/175	50/250

Standard Silt Fence (SF) is fabric rolls stapled to wooden stakes driven 16 inches in the ground.
Reinforced Silt Fence (RSF) is fabric placed against welded wire fabric with anchored steel posts driven 16 inches in the ground.
Super Silt Fence (SSF) is fabric placed against chain link fence as support backing with posts driven 3 feet in the ground.

4. Silt fence shall be removed as soon as the disturbed area has achieved final stabilization.

The silt fence shall be installed in accordance with the appropriate details. Where ends of filter cloth come together, they shall be overlapped, folded and stapled to prevent sediment bypass. Butt joints are not acceptable. A detail of the silt fence shall be shown on the plan. See Figure 5.30 on page 5.56 for Reinforced Silt Fence as an example of details to be provided.

Criteria for Silt Fence Materials

1. Silt Fence Fabric: The fabric shall meet the following specifications unless otherwise approved by the appropriate erosion and sediment control plan approval authority. Such approval shall not constitute statewide acceptance.

Fabric Properties	Minimum Acceptable Value	Test Method
Grab Tensile Strength (lbs)	110	ASTM D 4632
Elongation at Failure (%)	20	ASTM D 4632
Mullen Burst Strength (PSI)	300	ASTM D 3786
Puncture Strength (lbs)	60	ASTM D 4833
Minimum Trapezoidal Tear Strength (lbs)	50	ASTM D 4533
Flow Through Rate (gal/min/sf)	25	ASTM D 4491
Equivalent Opening Size	40-80	US Std Sieve ASTM D 4751
Minimum UV Residual (%)	70	ASTM D 4355

Super Silt Fence



2. Fence Posts (for fabricated units): The length shall be a minimum of 36 inches long. Wood posts will be of sound quality hardwood with a minimum cross sectional area of 3.5 square inches. Steel posts will be standard T and U section weighing not less than 1.00 pound per linear foot. Posts for super silt fence shall be standard chain link fence posts.
3. Wire Fence for reinforced silt fence: Wire fencing shall be a minimum 14 gage with a maximum 6 in. mesh opening, or as approved.
4. Prefabricated silt fence is acceptable as long as all material specifications are met.

Reinforced Silt Fence



**Figure 5.30
Reinforced Silt Fence**

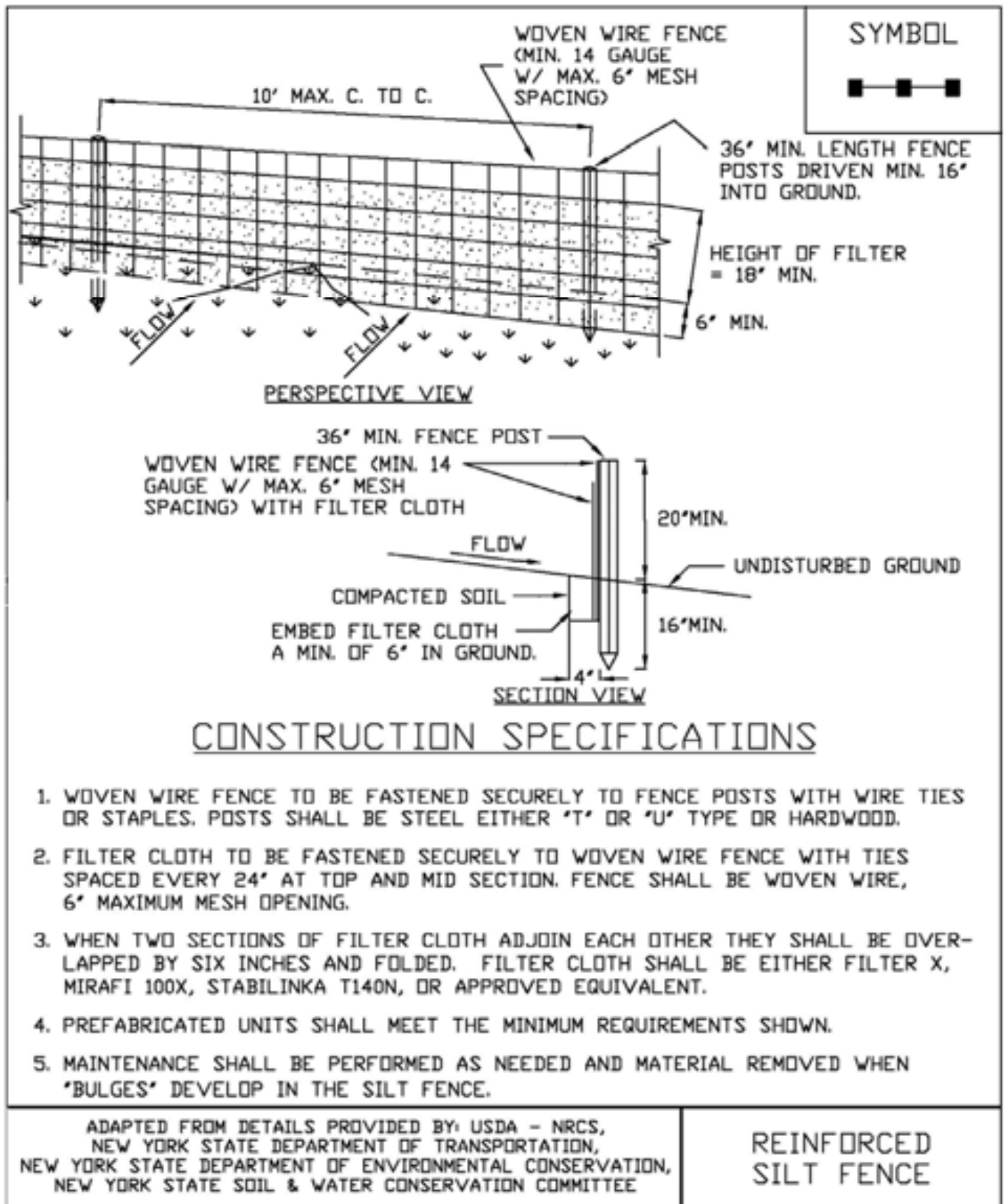

STANDARD AND SPECIFICATIONS FOR COMPOST FILTER SOCK



Definition & Scope

A **temporary** sediment control practice composed of a degradable geotextile mesh tube filled with compost filter media to filter sediment and other pollutants associated with construction activity to prevent their migration offsite.

Condition Where Practice Applies

Compost filter socks can be used in many construction site applications where erosion will occur in the form of sheet erosion and there is no concentration of water flowing to the sock. In areas with steep slopes and/or rocky terrain, soil conditions must be such that good continuous contact between the sock and the soil is maintained throughout its length. For use on impervious surfaces such as road pavement or parking areas, proper anchorage must be provided to prevent shifting of the sock or separation of the contact between the sock and the pavement. Compost filter socks are utilized both at the site perimeter as well as within the construction areas. These socks may be filled after placement by blowing compost into the tube pneumatically, or filled at a staging location and moved into its designed location.

Design Criteria

1. Compost filter socks will be placed on the contour with both terminal ends of the sock extended 8 feet upslope at a 45 degree angle to prevent bypass flow.
2. Diameters designed for use shall be 12" – 32" except

that 8" diameter socks may be used for residential lots to control areas less than 0.25 acres.

3. The flat dimension of the sock shall be at least 1.5 times the nominal diameter.
4. The **Maximum Slope Length** (in feet) above a compost filter sock shall not exceed the following limits:

Dia. (in.)	Slope %						
	2	5	10	20	25	33	50
8	225*	200	100	50	20	—	—
12	250	225	125	65	50	40	25
18	275	250	150	70	55	45	30
24	350	275	200	130	100	60	35
32	450	325	275	150	120	75	50

* Length in feet



5. The compost infill shall be well decomposed (matured at least 3 months), weed-free, organic matter. It shall be aerobically composted, possess no objectionable odors, and contain less than 1%, by dry weight, of man-made foreign matter. The physical parameters of the compost shall meet the standards listed in Table 5.2 - Compost Standards Table. **Note: All biosolids compost produced in New York State (or approved for importation) must meet NYS DEC's 6 NYCRR Part 360 (Solid Waste Management Facilities) requirements. The Part 360 requirements are equal to or more stringent than 40 CFR Part 503 which ensure safe standards for pathogen reduction and heavy metals content. When using compost filter socks adjacent to surface water, the compost should have a low nutrient value.**
6. The compost filter sock fabric material shall meet the

7. Compost filter socks shall be anchored in earth with 2” x 2” wooden stakes driven 12” into the soil on 10 foot centers on the centerline of the sock. On uneven terrain, effective ground contact can be enhanced by the placement of a fillet of filter media on the disturbed area side of the compost sock.
8. All specific construction details and material specifications shall appear on the erosion and sediment control constructions drawings when compost filter socks are included in the plan.
3. Socks shall be inspected weekly and after each runoff event. Damaged socks shall be repaired in the manner required by the manufacturer or replaced within 24 hours of inspection notification.
4. Biodegradable filter socks shall be replaced after 6 months; photodegradable filter socks after 1 year. Polypropylene socks shall be replaced according to the manufacturer’s recommendations.
5. Upon stabilization of the area contributory to the sock, stakes shall be removed. The sock may be left in place and vegetated or removed in accordance with the stabilization plan. For removal the mesh can be cut and the compost spread as an additional mulch to act as a soil supplement.

Maintenance

1. Traffic shall not be permitted to cross filter socks.
2. Accumulated sediment shall be removed when it reaches half the above ground height of the sock and disposed of in accordance with the plan.

Table 5.1 - Compost Sock Fabric Minimum Specifications Table

Material Type	3 mil HDPE	5 mil HDPE	5 mil HDPE	Multi-Filament Polypropylene (MFPP)	Heavy Duty Multi-Filament Polypropylene (HDMFPP)
Material Characteristics	Photodegradable	Photodegradable	Biodegradable	Photodegradable	Photodegradable
Sock Diameters	12” 18”	12” 18” 24” 32”	12” 18” 24” 32”	12” 18” 24” 32”	12” 18” 24” 32”
Mesh Opening	3/8”	3/8”	3/8”	3/8”	1/8”
Tensile Strength		26 psi	26 psi	44 psi	202 psi
Ultraviolet Stability % Original Strength (ASTM G-155)	23% at 1000 hr.	23% at 1000 hr.		100% at 1000 hr.	100% at 1000 hr.
Minimum Functional Longevity	6 months	9 months	6 months	1 year	2 years

Table 5.2 - Compost Standards Table

Organic matter content	25% - 100% (dry weight)
Organic portion	Fibrous and elongated
pH	6.0 – 8.0
Moisture content	30% - 60%
Particle size	100% passing a 1” screen and 10 - 50% passing a 3/8” screen
Soluble salt concentration	5.0 dS/m (mmhos/cm) maximum

Figure 5.2
Compost Filter Sock

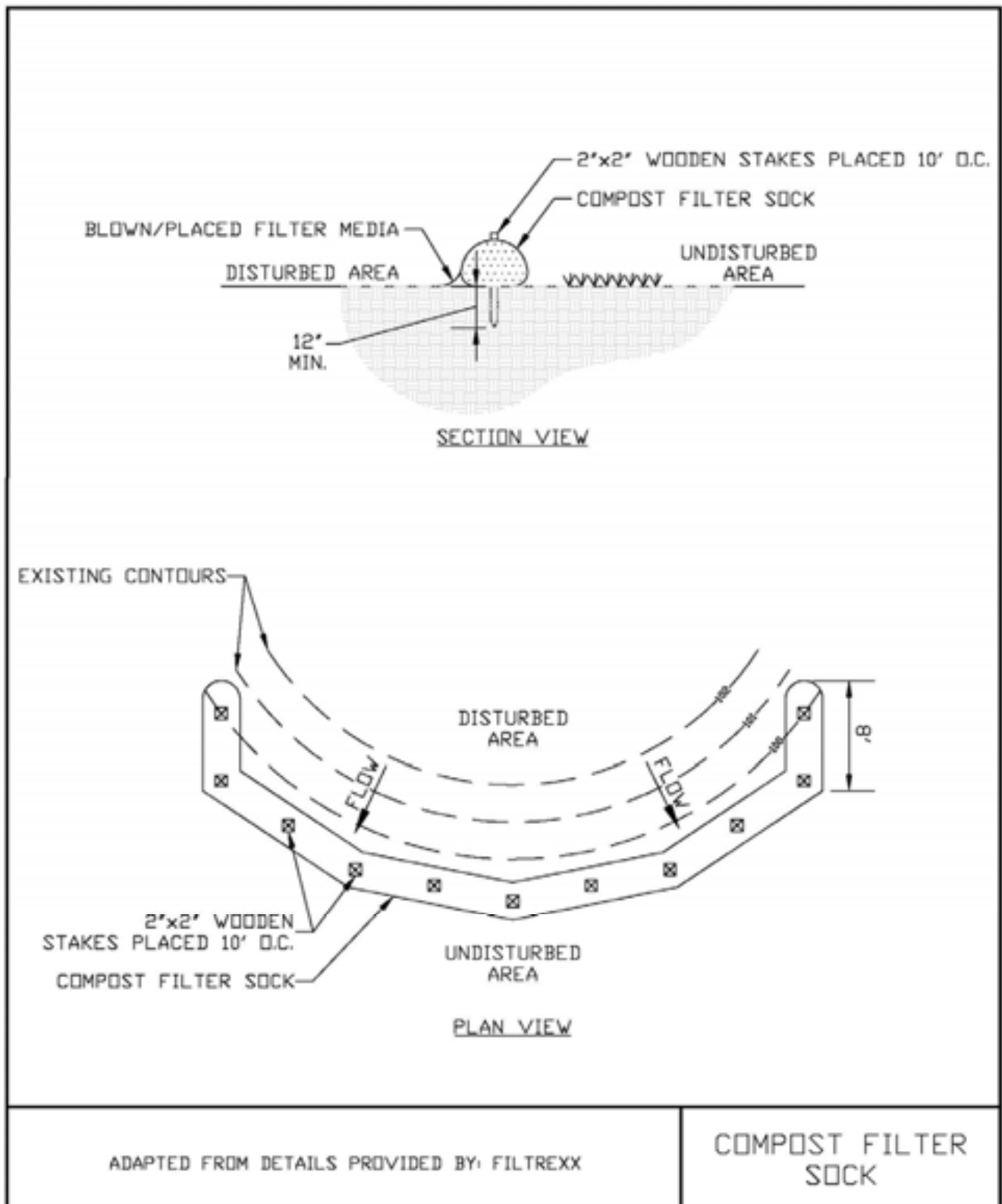

STANDARD AND SPECIFICATIONS FOR FIBER ROLL



Definition & Scope

A fiber roll is a coir (coconut fiber), straw, or excelsior roll encased in netting of jute, nylon, or burlap to dissipate energy along streambanks, channels, and bodies of water and to reduce sheet flow on slopes.

Conditions Where Practice Applies

Fiber rolls are used where the water surface levels are relatively constant. Artificially controlled streams for hydropower are not good candidates for this technique. The rolls provide a good medium for the introduction of herbaceous vegetation. Planting in the fiber roll is appropriate where the roll will remain continuously wet.

Design Criteria

1. The roll is placed in a shallow trench dug below baseflow or in a 4 inch trench on the slope contour and anchored by 2" x 2", 3-foot long posts driven on each side of the roll (see Figure 4.8).
2. The roll is contained by a 9-gauge non-galvanized wire placed over the roll from post to post. Braided nylon rope (1/8" thick) may be used.
3. The anchor posts shall be spaced laterally 4 feet on center on both sides of the roll and driven down to the top of the roll.
4. Soil is placed behind the roll and planted with suitable herbaceous or woody vegetation. If the roll will be continuously saturated, wetland plants may be planted into voids created in the upper surface of the roll.
5. Where water levels may fall below the bottom edge of the roll, a brush layer of willow should be installed so

as to lay across the top edge of the roll.

6. Where fiber rolls are used to reduce sheet flow on slopes they should be at least 12" in diameter and spaced according to the straw bale dike standard for sediment control.

Maintenance

Due to the susceptibility of plant materials to the physical constraints of the site, climate conditions, and animal populations, it is necessary to inspect installations frequently. This is especially important during the first year or two of establishment. Plant materials missing or damaged should be replaced as soon as possible. Sloughs or breaks in drainage pattern should be reestablished for the site as quickly as possible to maintain stability.



**Figure 4.8
Fiber Roll**

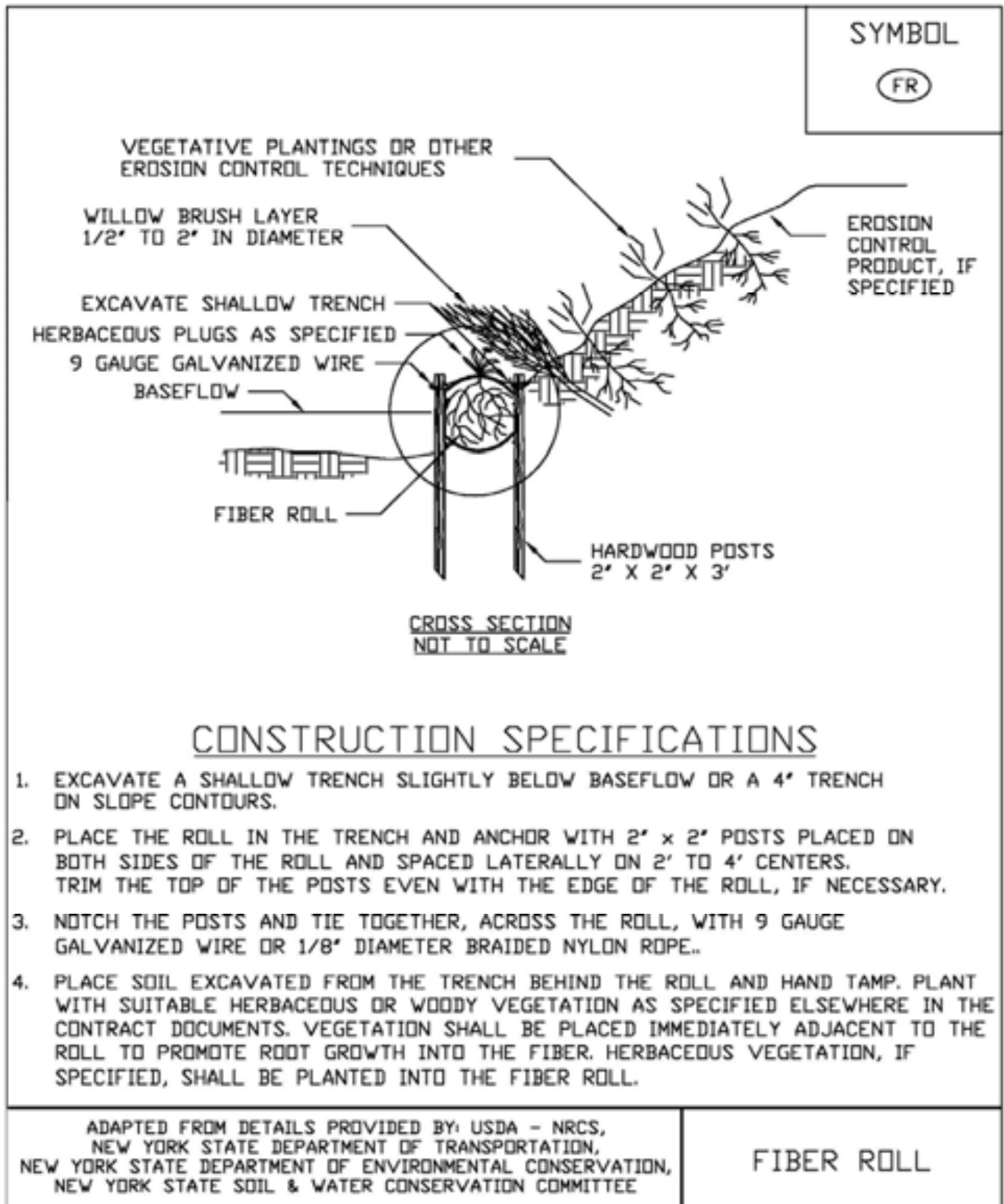

STANDARD AND SPECIFICATIONS FOR CONCRETE TRUCK WASHOUT



Definition & Scope

A temporary excavated or above ground lined constructed pit where concrete truck mixers and equipment can be washed after their loads have been discharged, to prevent highly alkaline runoff from entering storm drainage systems or leaching into soil.

Conditions Where Practice Applies

Washout facilities shall be provided for every project where concrete will be poured or otherwise formed on the site. This facility will receive highly alkaline wash water from the cleaning of chutes, mixers, hoppers, vibrators, placing equipment, trowels, and screeds. Under no circumstances will wash water from these operations be allowed to infiltrate into the soil or enter surface waters.

Design Criteria

Capacity: The washout facility should be sized to contain solids, wash water, and rainfall and sized to allow for the evaporation of the wash water and rainfall. Wash water shall be estimated at 7 gallons per chute and 50 gallons per hopper of the concrete pump truck and/or discharging drum. The minimum size shall be 8 feet by 8 feet at the bottom and 2 feet deep. If excavated, the side slopes shall be 2 horizontal to 1 vertical.

Location: Locate the facility a minimum of 100 feet from drainage swales, storm drain inlets, wetlands, streams and other surface waters. Prevent surface water from entering the structure except for the access road. Provide appropriate access with a gravel access road sloped down to the structure. Signs shall be placed to direct drivers to the facility after their load is discharged.

Liner: All washout facilities will be lined to prevent

leaching of liquids into the ground. The liner shall be plastic sheeting with a minimum thickness of 10 mils with no holes or tears, and anchored beyond the top of the pit with an earthen berm, sand bags, stone, or other structural appurtenance except at the access point.

If pre-fabricated washouts are used they must ensure the capture and containment of the concrete wash and be sized based on the expected frequency of concrete pours. They shall be sited as noted in the location criteria.

Maintenance

- All concrete washout facilities shall be inspected daily. Damaged or leaking facilities shall be deactivated and repaired or replaced immediately. Excess rainwater that has accumulated over hardened concrete should be pumped to a stabilized area, such as a grass filter strip.
- Accumulated hardened material shall be removed when 75% of the storage capacity of the structure is filled. Any excess wash water shall be pumped into a containment vessel and properly disposed of off site.
- Dispose of the hardened material off-site in a construction/demolition landfill. On-site disposal may be allowed if this has been approved and accepted as part of the projects SWPPP. In that case, the material should be recycled as specified, or buried and covered with a minimum of 2 feet of clean compacted earthfill that is permanently stabilized to prevent erosion.
- The plastic liner shall be replaced with each cleaning of the washout facility.
- Inspect the project site frequently to ensure that no concrete discharges are taking place in non-designated areas.

STANDARD AND SPECIFICATIONS FOR CHECK DAM



Definition & Scope

Small barriers or dams constructed of stone, bagged sand or gravel, or other durable materials across a drainageway to reduce erosion in a drainage channel by reducing the velocity of flow in the channel.

Conditions Where Practice Applies

This practice is used as a **temporary** and, in some cases, a **permanent** measure to limit erosion by reducing velocities in open channels that are degrading or subject to erosion or where permanent stabilization is impractical due to short period of usefulness and time constraints of construction.

Design Criteria

Drainage Area: Maximum drainage area above the check dam shall not exceed two (2) acres.

Height: Not greater than 2 feet. Center shall be maintained 9 inches lower than abutments at natural ground elevation.

Side Slopes: Shall be 2:1 or flatter.

Spacing: The check dams shall be spaced as necessary in the channel so that the crest of the downstream dam is at the elevation of the toe of the upstream dam. This spacing is equal to the height of the check dam divided by the channel slope.

Therefore:
$$S = \frac{h}{s}$$

Where: S = spacing interval (ft.)
h = height of check dam (ft.)
s = channel slope (ft./ft.)

Example:

For a channel with and 2 ft. high stone they are spaced as
$$S = \frac{2 \text{ ft}}{0.04 \frac{\text{ft}}{\text{ft}}} = 50 \text{ ft}$$
 a 4% slope check dams, follows:

For stone check dams: Use a well graded stone matrix 2 to 9 inches in size (NYS – DOT Light Stone Fill meets these requirements).

The overflow of the check dams will be stabilized to resist erosion that might be caused by the check dam. See Figure 3.1 on page 3.3 for details.

Check dams should be anchored in the channel by a cutoff trench 1.5 ft. wide and 0.5 ft. deep and lined with filter fabric to prevent soil migration.

For filter sock or fiber roll check dams: The check dams will be anchored by staking the dam to the earth contact surface. The dam will extend to the top of the bank. The check dam will have a splash apron of NYS DOT #2 crushed stone extending a minimum 3 feet downstream from the dam and 1 foot up the sides of the channel. The compost and materials for a filter sock check dam shall meet the requirements shown in the standard for Compost Filter Sock on page 5.7.

Maintenance

The check dams should be inspected after each runoff event. Correct all damage immediately. If significant erosion has occurred between structures, a liner of stone or other suitable material should be installed in that portion of the channel or additional check dams added.

Remove sediment accumulated behind the dam as needed to allow channel to drain through the stone check dam and prevent large flows from carrying sediment over the dam.

Figure 3.1
Stone Check Dam Detail

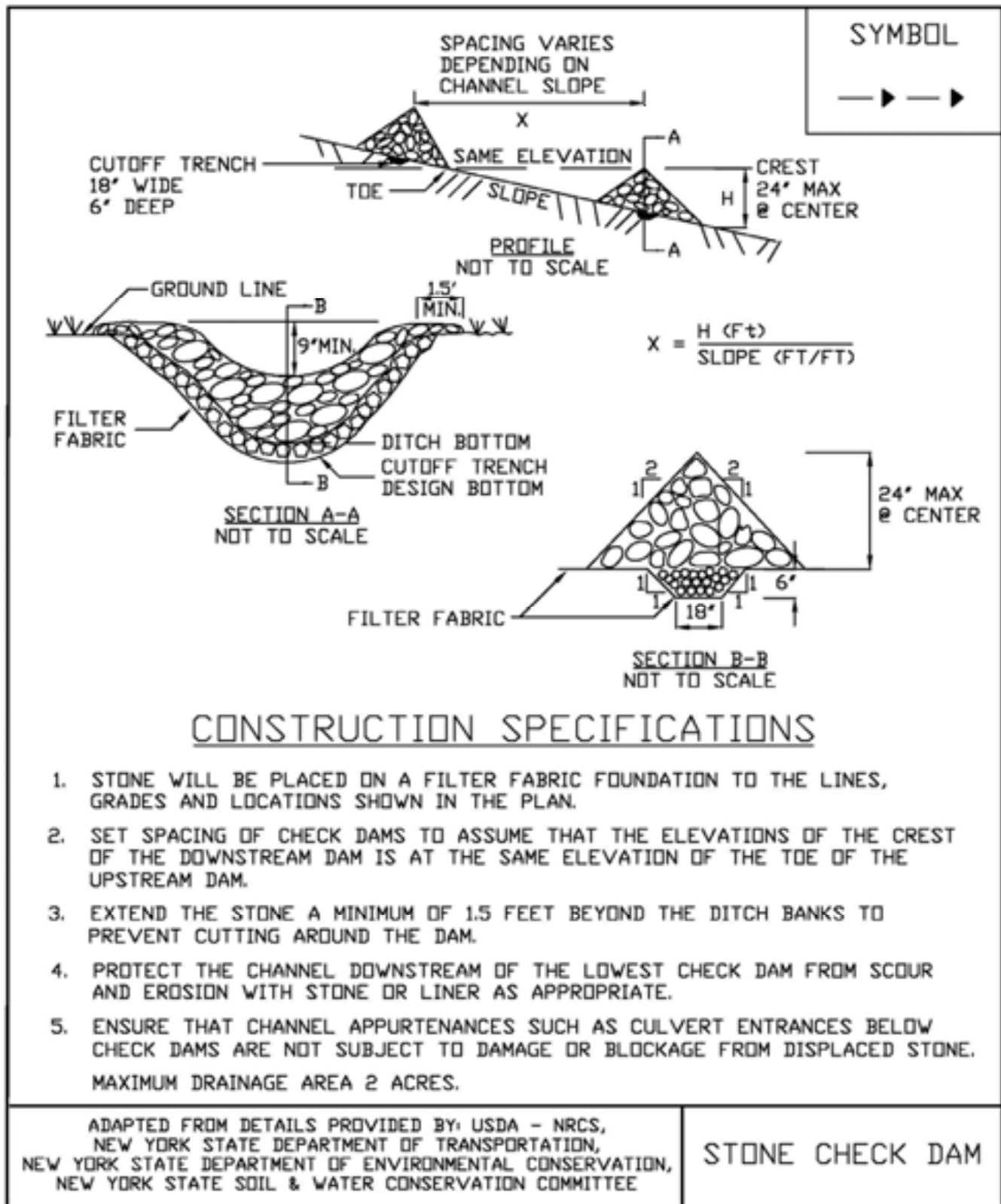

STANDARD AND SPECIFICATIONS FOR DEWATERING SUMP PIT



Discharge of turbid water pumped from the standpipe should be to a sediment trap, sediment basin, filter bag or stabilized area, such as a filter strip. If water from the sump pit will be pumped directly to a storm drain system, filter cloth with an equivalent sieve size between 40-80 should be wrapped around the standpipe to ensure clean water discharge. It is recommended that $\frac{1}{4}$ to $\frac{1}{2}$ inch hardware cloth be wrapped around and secured to the standpipe prior to attaching the filter cloth. This will increase the rate of water seepage into the standpipe.

Definition & Scope

A **temporary** pit which is constructed using pipe and stone for pumping excessive water from excavations to a suitable discharge area.

Conditions Where Practice Applies

Sump pits are constructed when water collects during the excavation phase of construction. This practice is particularly useful in urban areas during excavation for building foundations. It may also be necessary during construction activities that encounter high ground water tables in floodplain locations.

Design Criteria

The number of sump pits and their locations shall be determined by the contractor/engineer. A design is not required, but construction should conform to the general criteria outlined on Figure 3.3 on page 3.8.

A perforated vertical standpipe is placed in the center of the pit and surrounded with a stone screening material to collect filtered water. Water is then pumped from the center of the pipe to a suitable discharge area.



**Figure 3.3
Dewatering Sump Pit Detail**

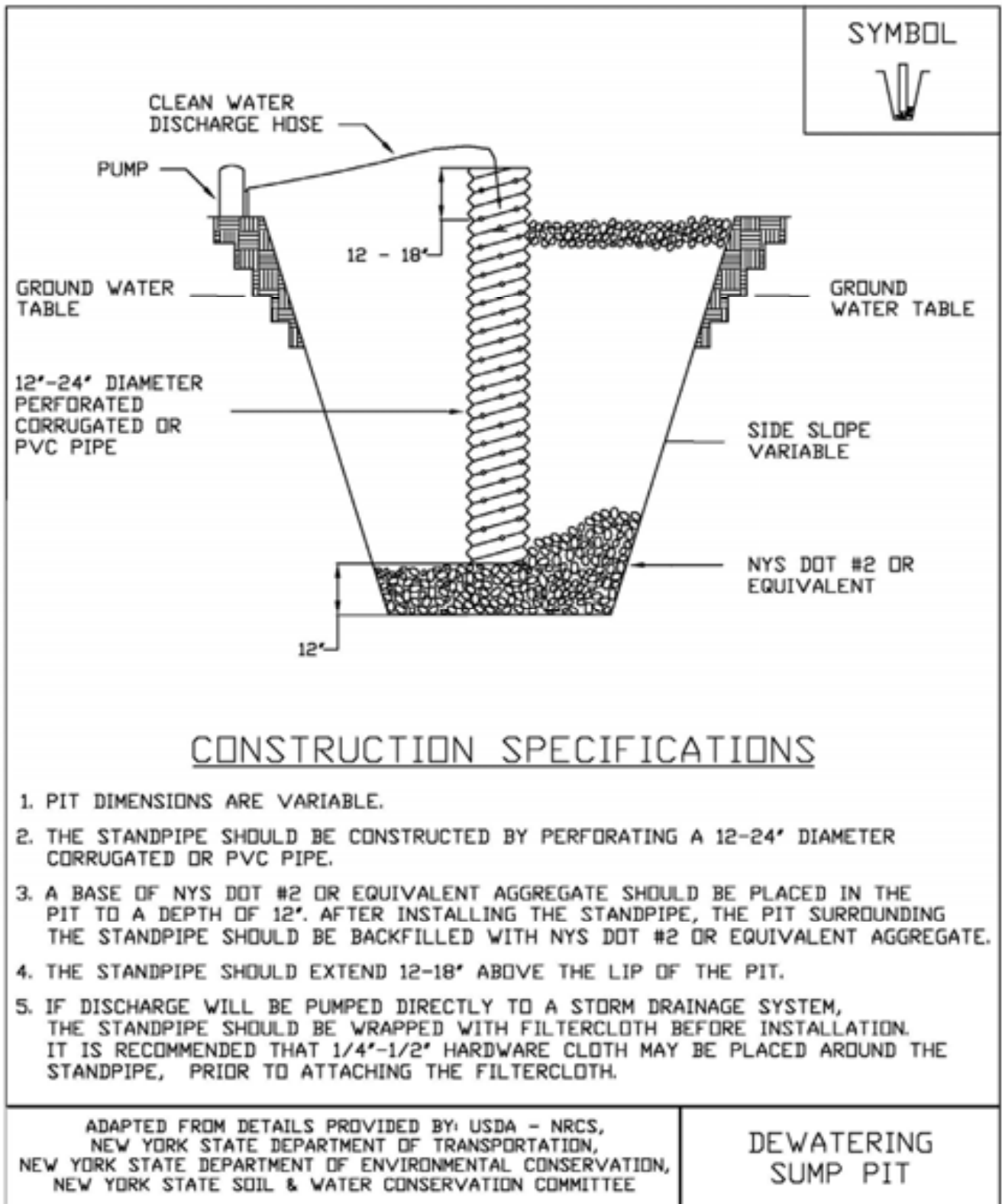

STANDARD AND SPECIFICATIONS FOR DUST CONTROL



Definition & Scope

The control of dust resulting from land-disturbing activities, to prevent surface and air movement of dust from disturbed soil surfaces that may cause off-site damage, health hazards, and traffic safety problems.

Conditions Where Practice Applies

On construction roads, access points, and other disturbed areas subject to surface dust movement and dust blowing where off-site damage may occur if dust is not controlled.

Design Criteria

Construction operations should be scheduled to minimize the amount of area disturbed at one time. Buffer areas of vegetation should be left where practical. Temporary or permanent stabilization measures shall be installed. No specific design criteria is given; see construction specifications below for common methods of dust control.

Water quality must be considered when materials are selected for dust control. Where there is a potential for the material to wash off to a stream, ingredient information must be provided to the NYSDEC.

No polymer application shall take place without written approval from the NYSDEC.

Construction Specifications

A. Non-driving Areas – These areas use products and materials applied or placed on soil surfaces to prevent airborne migration of soil particles.

Vegetative Cover – For disturbed areas not subject to traffic, vegetation provides the most practical method of

dust control (see Section 3).

Mulch (including gravel mulch) – Mulch offers a fast effective means of controlling dust. This can also include rolled erosion control blankets.

Spray adhesives – These are products generally composed of polymers in a liquid or solid form that are mixed with water to form an emulsion that is sprayed on the soil surface with typical hydroseeding equipment. The mixing ratios and application rates will be in accordance with the manufacturer's recommendations for the specific soils on the site. In no case should the application of these adhesives be made on wet soils or if there is a probability of precipitation within 48 hours of its proposed use. Material Safety Data Sheets will be provided to all applicators and others working with the material.

B. Driving Areas – These areas utilize water, polymer emulsions, and barriers to prevent dust movement from the traffic surface into the air.

Sprinkling – The site may be sprayed with water until the surface is wet. This is especially effective on haul roads and access route to provide short term limited dust control.

Polymer Additives – These polymers are mixed with water and applied to the driving surface by a water truck with a gravity feed drip bar, spray bar or automated distributor truck. The mixing ratios and application rates will be in accordance with the manufacturer's recommendations. Incorporation of the emulsion into the soil will be done to the appropriate depth based on expected traffic. Compaction after incorporation will be by vibratory roller to a minimum of 95%. The prepared surface shall be moist and no application of the polymer will be made if there is a probability of precipitation within 48 hours of its proposed use. Material Safety Data Sheets will be provided to all applicators working with the material.

Barriers – Woven geo-textiles can be placed on the driving surface to effectively reduce dust throw and particle migration on haul roads. Stone can also be used for construction roads for effective dust control.

Windbreak – A silt fence or similar barrier can control air currents at intervals equal to ten times the barrier height. Preserve existing wind barrier vegetation as much as practical.

Maintenance

Maintain dust control measures through dry weather periods until all disturbed areas are stabilized.

STANDARD AND SPECIFICATIONS FOR GRASSED WATERWAY



Definition & Scope

A natural or **permanent** man-made channel of parabolic or trapezoidal cross-section that is below adjacent ground level and is stabilized by suitable vegetation. The flow channel is normally wide and shallow and conveys the runoff down the slope without causing damage by erosion.

Conditions Where Practice Applies

Grass waterways are used where added vegetative protection is needed to control erosion resulting from concentrated runoff.

Design Criteria

Capacity

The minimum capacity shall be that required to confine the peak rate of runoff expected from a 10-year 24 hour frequency rainfall event or a higher frequency corresponding to the hazard involved. This requirement for confinement may be waived on slopes of less than one (1) percent where out-of-bank flow will not cause erosion or property damage.

Peak rates of runoff values used in determining the capacity requirements shall be computed by appropriate methods. Where there is base flow, it shall be handled by a stone center, subsurface drain, or other suitable means since sustained wetness usually prevents adequate vegetative cover. The cross-sectional area of the stone center or subsurface drain size to be provided shall be determined by using a flow rate of 0.1 cfs/acre or by actual measurement of the maximum base flow.

Velocity

Please see Table 3.1, Diversion Maximum Permissible Design Velocities on page 3.10, for seed, soil, and velocity variables.

Cross Section

The design water surface elevation of a grassed waterway receiving water from diversions or other tributary channels shall be equal to or less than the design water surface elevation in the diversion or other tributary channels.

The top width of parabolic waterways shall not exceed 30 feet and the bottom width of trapezoidal waterways shall not exceed 15 feet unless multiple or divided waterways, stone center, or other means are provided to control meandering of low flows.

Structural Measures

In cases where grade or erosion problems exist, special control measures may be needed such as lined waterways (see page 3.27), or grade stabilization measures (see page 3.21). Where needed, these measures will be supported by adequate design computations. For typical cross sections of waterways with riprap sections or stone centers, refer to Figure 3.8 on page 3.24.

The design procedures for parabolic and trapezoidal channels are available in the NRCS Engineering Field Handbook. Figure 3.9 on page 3.25 also provides a design chart for parabolic waterway.

Outlets

Each waterway shall have a stable outlet. The outlet may be another waterway, a stabilized open channel, grade stabilization structure, etc. In all cases, the outlet must discharge in such a manner as not to cause erosion. Outlets shall be constructed and stabilized prior to the operation of the waterway.

Stabilization

Waterways shall be stabilized in accordance with the appropriate vegetative stabilization standard and specifications, and will be dependent on such factors as slope, soil class, etc. See standard for Vegetating Waterways on Page 4.78.

Construction Specifications

See Figure 3.10 on page 3.26 for details.

Figure 3.8
Typical Waterway Cross Sections Details

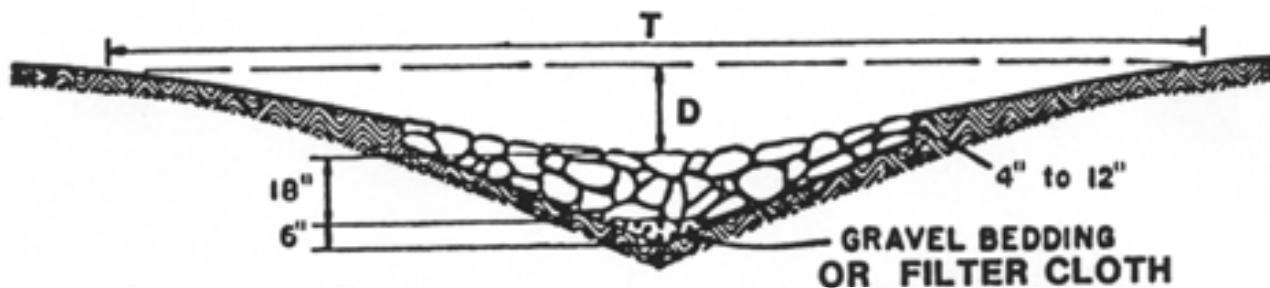

Waterway with stone center drain. "V" section shaped by motor grader.

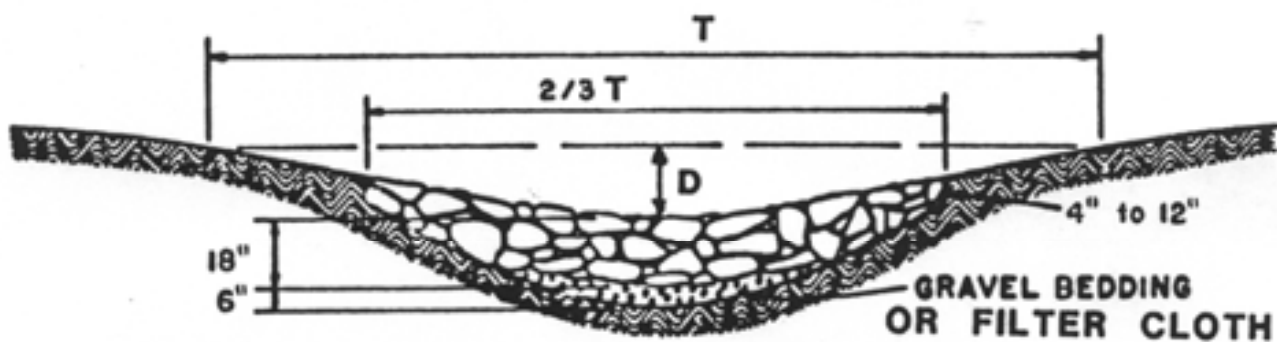

Waterway with stone center drain. Rounded section shaped by bulldozer.

Figure 3.9
Parabolic Waterway Design Chart (USDA - NRCS)

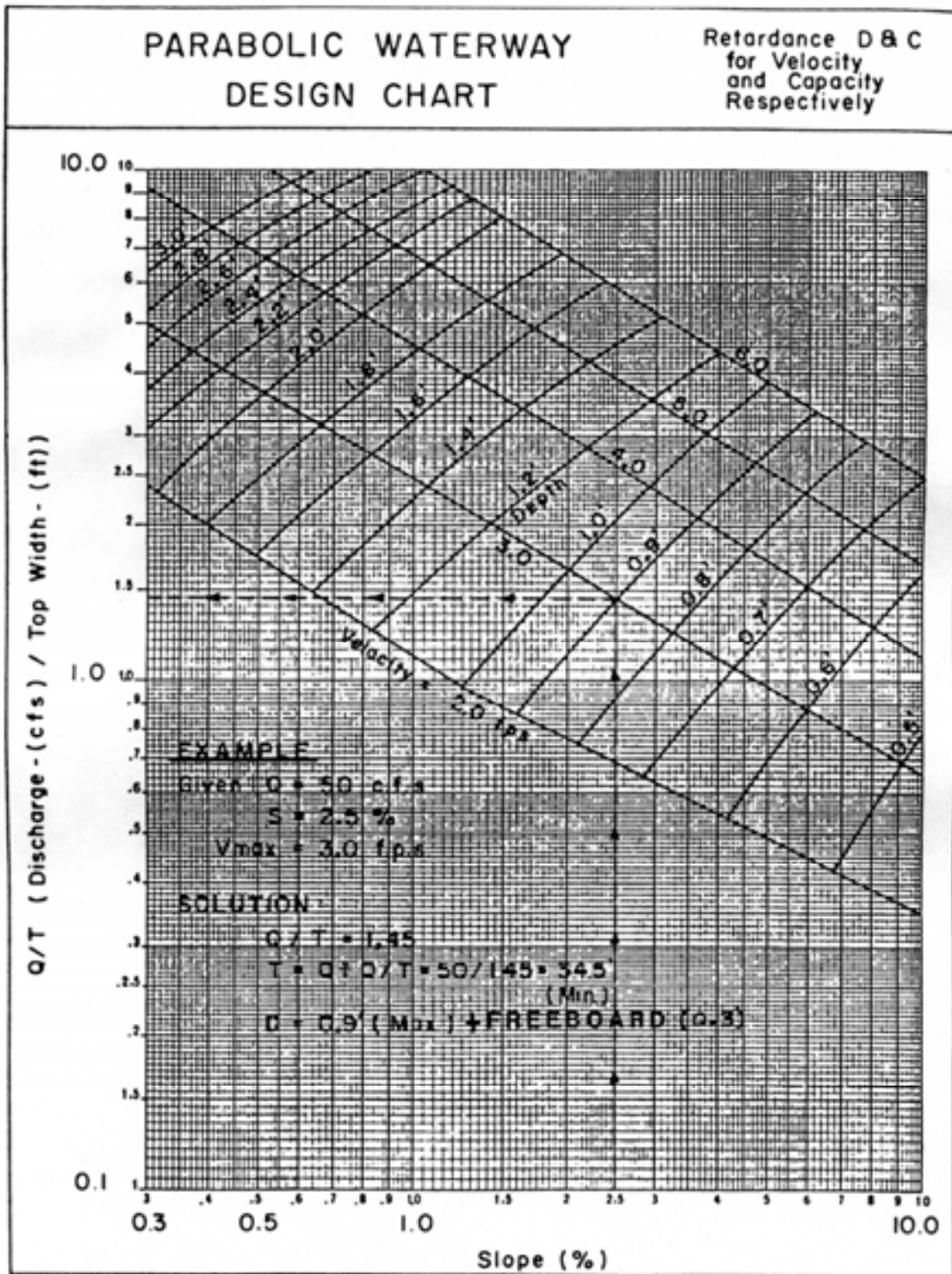

**Figure 3.10
Grassed Waterway Detail**

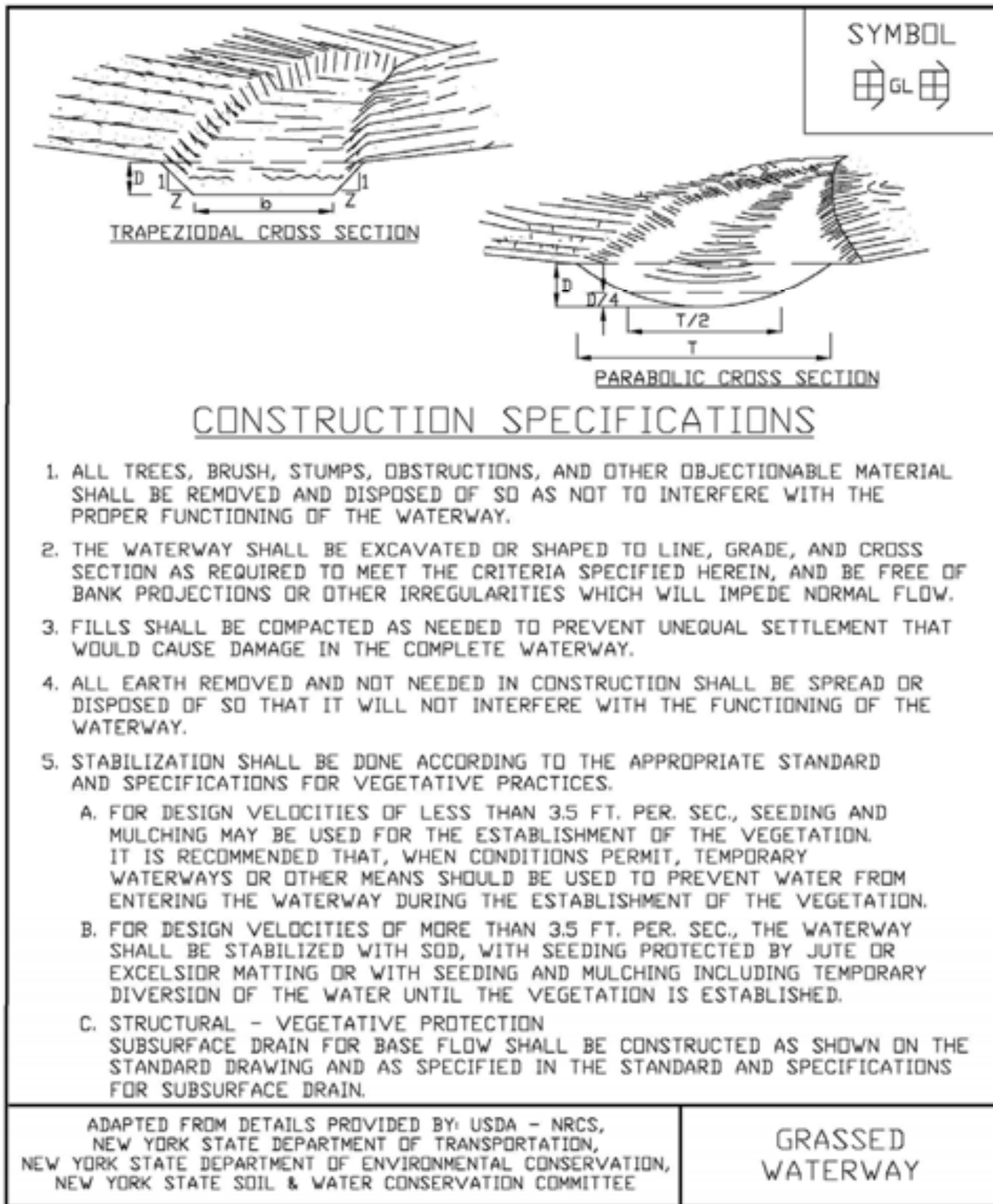

STANDARD AND SPECIFICATIONS FOR STORM DRAIN INLET PROTECTION



Definition & Scope

A **temporary** barrier with low permeability, installed around inlets in the form of a fence, berm or excavation around an opening, detaining water and thereby reducing the sediment content of sediment laden water by settling thus preventing heavily sediment laden water from entering a storm drain system.

Conditions Where Practice Applies

This practice shall be used where the drainage area to an inlet is disturbed, it is not possible to temporarily divert the storm drain outfall into a trapping device, and watertight blocking of inlets is not advisable. **It is not to be used in place of sediment trapping devices.** This practice shall be used with an upstream buffer strip if placed at a storm drain inlet on a paved surface. It may be used in conjunction with storm drain diversion to help prevent siltation of pipes installed with low slope angle.

Types of Storm Drain Inlet Practices

There are five (5) specific types of storm drain inlet protection practices that vary according to their function, location, drainage area, and availability of materials:

- I. Excavated Drop Inlet Protection
- II. Fabric Drop Inlet Protection
- III. Stone & Block Drop Inlet Protection
- IV. Paved Surface Inlet Protection
- V. Manufactured Insert Inlet Protection

Design Criteria

Drainage Area – The drainage area for storm drain inlets shall not exceed one acre. Erosion control/temporary stabilization measures must be implemented on the disturbed

drainage area tributary to the inlet. The crest elevations of these practices shall provide storage and minimize bypass flow.

Type I – Excavated Drop Inlet Protection

This practice is generally used during initial overlot grading after the storm drain trunk line is installed.

Limit the drainage area to the inlet device to 1 acre. Excavated side slopes shall be no steeper than 2:1. The minimum depth shall be 1 foot and the maximum depth 2 feet as measured from the crest of the inlet structure. Shape the excavated basin to fit conditions with the longest dimension oriented toward the longest inflow area to provide maximum trap efficiency. The capacity of the excavated basin should be established to contain 900 cubic feet per acre of disturbed area. Weep holes, protected by fabric and stone, should be provided for draining the temporary pool.

Inspect and clean the excavated basin after every storm. Sediment should be removed when 50 percent of the storage volume is achieved. This material should be incorporated into the site in a stabilized manner.

Type II – Fabric Drop Inlet Protection



This practice is generally used during final elevation grading phases after the storm drain system is completed.

Limit the drainage area to 1 acre per inlet device. Land area slope immediately surrounding this device should not exceed 1 percent. The maximum height of the fabric above the inlet crest shall not exceed 1.5 feet unless reinforced.

The top of the barrier should be maintained to allow overflow to drop into the drop inlet and not bypass the inlet to

unprotected lower areas. Support stakes for fabric shall be a minimum of 3 feet long, spaced a maximum 3 feet apart. They should be driven close to the inlet so any overflow drops into the inlet and not on the unprotected soil. Improved performance and sediment storage volume can be obtained by excavating the area.

Inspect the fabric barrier after each rain event and make repairs as needed. Remove sediment from the pool area as necessary with care not to undercut or damage the filter fabric. Upon stabilization of the drainage area, remove all materials and unstable sediment and dispose of properly. Bring the adjacent area of the drop inlet to grade, smooth and compact and stabilize in the appropriate manner to the site.

Type III – Stone and Block Drop Inlet Protection

This practice is generally used during the initial and intermediate overlot grading of a construction site.

Limit the drainage area to 1 acre at the drop inlet. The stone barrier should have a minimum height of 1 foot and a maximum height of 2 feet. Do not use mortar. The height should be limited to prevent excess ponding and bypass flow.

Recess the first course of blocks at least 2 inches below the crest opening of the storm drain for lateral support. Subsequent courses can be supported laterally if needed by placing a 2x4 inch wood stud through the block openings perpendicular to the course. The bottom row should have a few blocks oriented so flow can drain through the block to dewater the basin area.

The stone should be placed just below the top of the blocks on slopes of 2:1 or flatter. Place hardware cloth of wire mesh with ½ inch openings over all block openings to hold stone in place.

As an optional design, the concrete blocks may be omitted and the entire structure constructed of stone, ringing the outlet (“doughnut”). The stone should be kept at a 3:1 slope toward the inlet to keep it from being washed into the inlet. A level area 1 foot wide and four inches below the crest will further prevent wash. Stone on the slope toward the inlet should be at least 3 inches in size for stability and 1 inch or smaller away from the inlet to control flow rate. The elevation of the top of the stone crest must be maintained 6 inches lower than the ground elevation down slope from the inlet to ensure that all storm flows pass over the stone into the storm drain and not past the structure. Temporary diking should be used as necessary to prevent bypass flow.

The barrier should be inspected after each rain event and repairs made where needed. Remove sediment as necessary to provide for accurate storage volume for subsequent rains. Upon stabilization of contributing drainage area, remove all

materials and any unstable soil and dispose of properly.

Bring the disturbed area to proper grade, smooth, compact and stabilize in a manner appropriate to the site.

Type IV – Paved Surface Inlet Protection



This practice is generally used after pavement construction has been done while final grading and soil stabilization is occurring. These practices should be used with upstream buffer strips in linear construction applications, and with temporary surface stabilization for overlot areas, to reduce the sediment load at the practice. This practice includes sand bags, compost filter socks, geo-tubes filled with ballast, and manufactured surface barriers. Pea gravel can also be used in conjunction with these practices to improve performance. When the inlet is not at a low point, and is offset from the pavement or gutter line, protection should be selected and installed so that flows are not diverted around the inlet.



The drainage area should be limited to 1 acre at the drain inlet. All practices will be placed at the inlet perimeter or beyond to maximize the flow capacity of the inlet. Practices shall be weighted, braced, tied, or otherwise anchored to prevent movement or shifting of location on paved surfaces. Traffic safety shall be integrated with the use of this practice. All practices should be marked with traffic safety cones as appropriate. Structure height shall not cause flooding or by-pass flow that would cause additional erosion.

The structure should be inspected after every storm event. Any sediment should be removed and disposed of on the site. Any broken or damaged components should be replaced. Check all materials for proper anchorage and secure as necessary.

Type V - Manufactured Insert Inlet Protection



The drainage area shall be limited to 1 acre at the drain inlet. All inserts will be installed and anchored in accordance with the manufacturers recommendations and design details. The fabric portion of the structure will equal or exceed the performance standard for the silt fence fabric. The inserts will be installed to preserve a minimum of 50 percent of the open, unobstructed design flow area of the storm drain inlet opening to maintain capacity for storm events.

**Figure 5.31
Excavated Drop Inlet Protection**

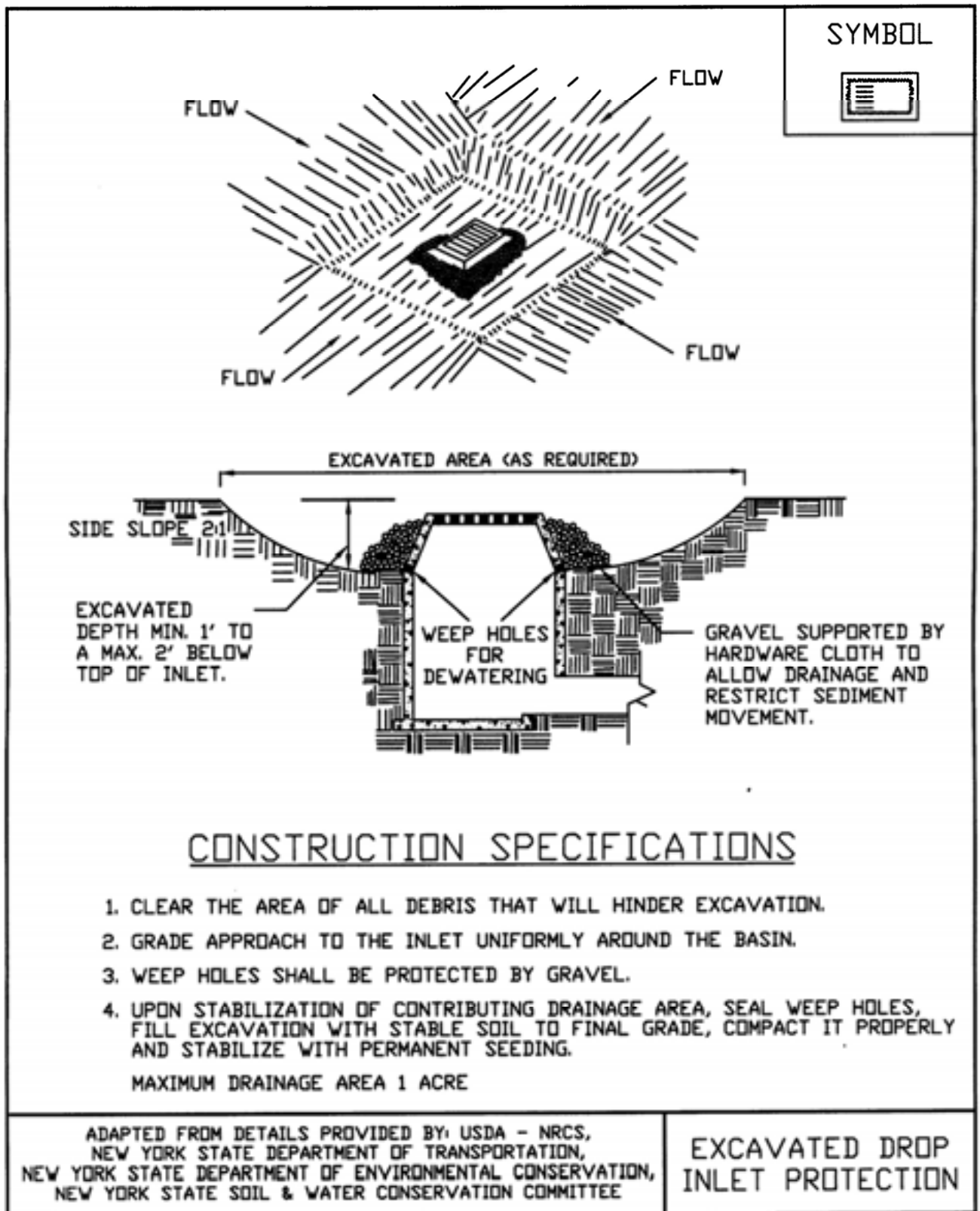

**Figure 5.32
Fabric Drop Inlet Protection**

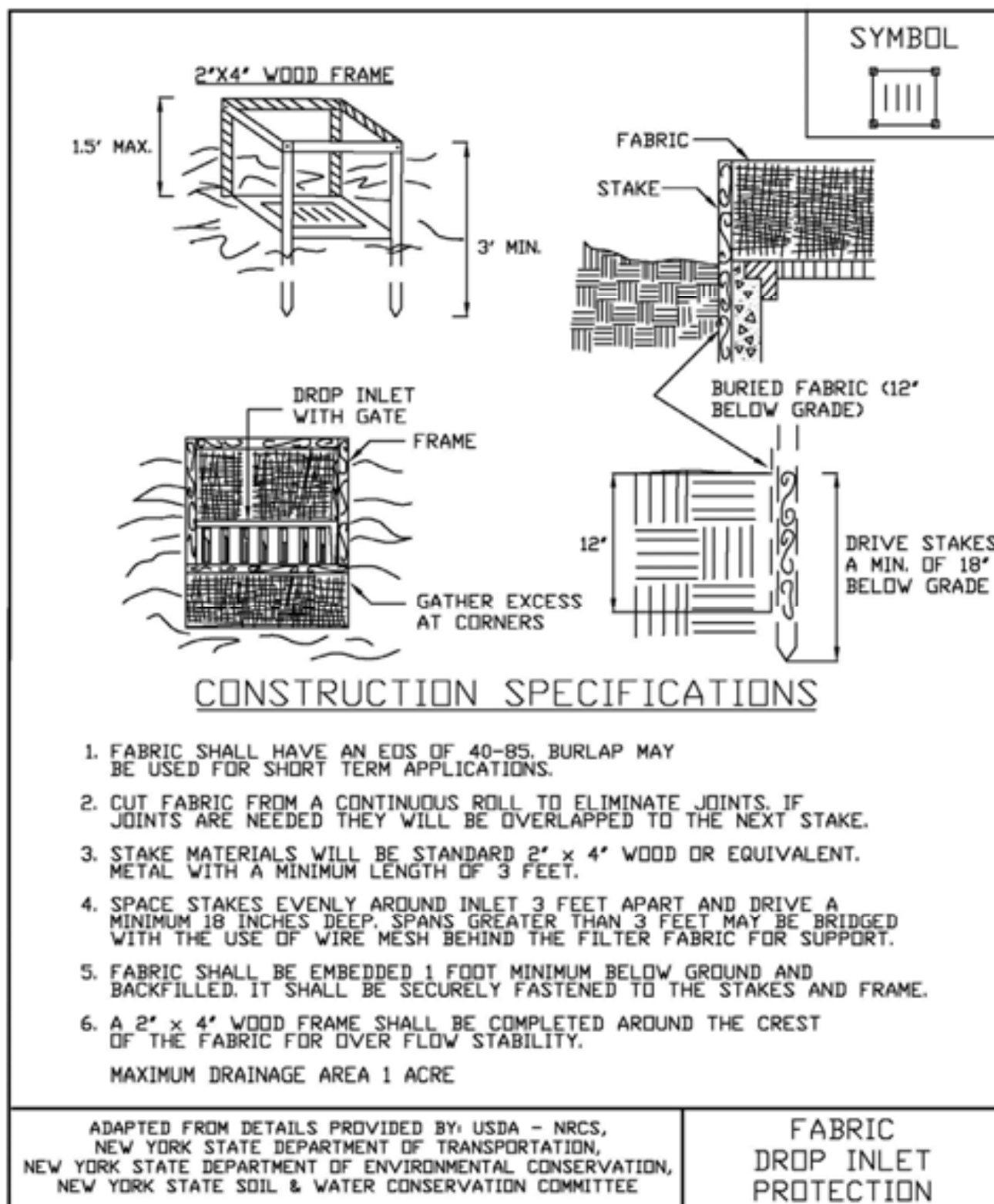

**Figure 5.33
Stone & Block Drop Inlet Protection**

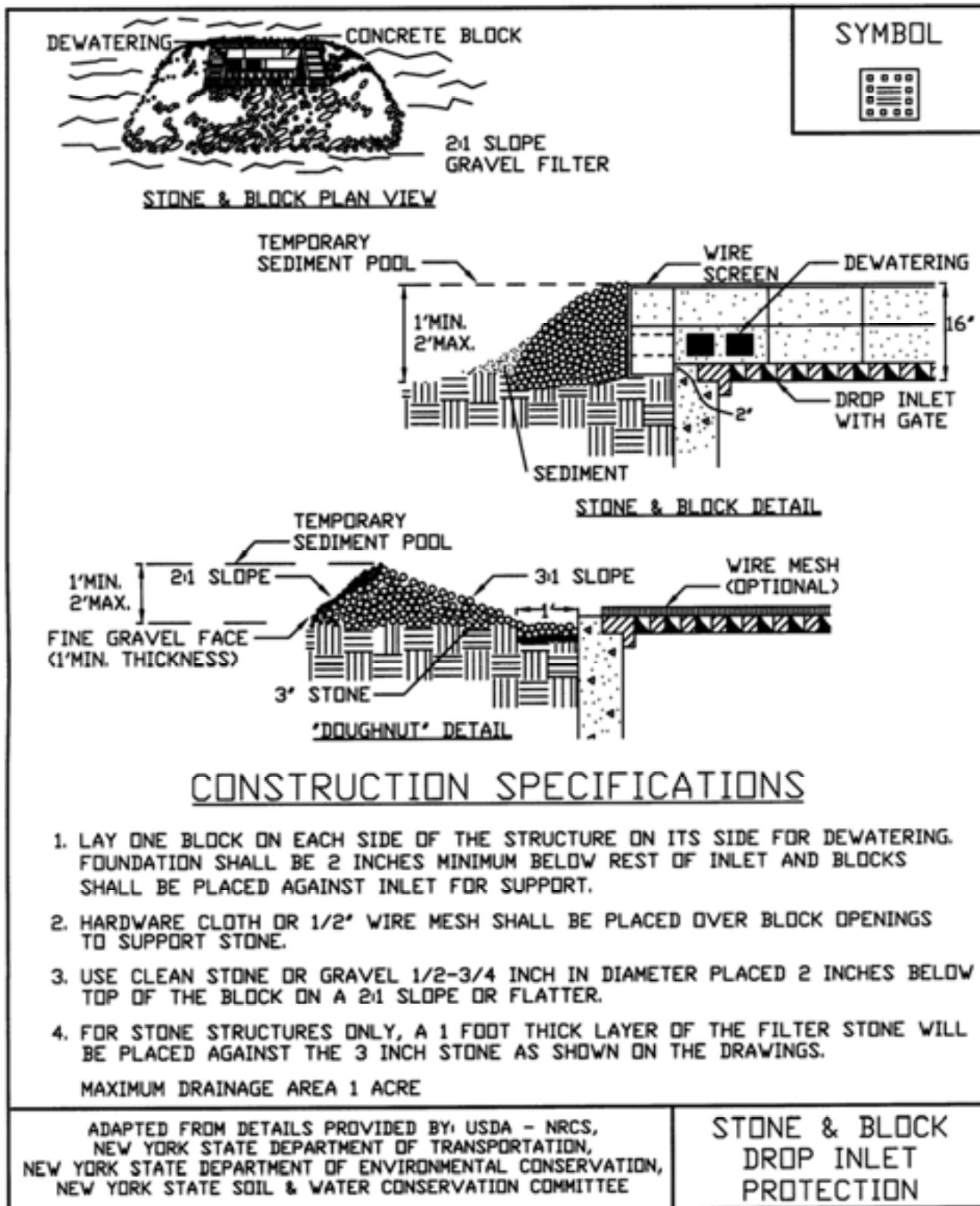

STANDARD AND SPECIFICATIONS FOR LANDGRADING



Definition & Scope

Permanent reshaping of the existing land surface by grading in accordance with an engineering topographic plan and specification to provide for erosion control and vegetative establishment on disturbed, reshaped areas.

Design Criteria

The grading plan should be based upon the incorporation of building designs and street layouts that fit and utilize existing topography and desirable natural surrounding to avoid extreme grade modifications. Information submitted must provide sufficient topographic surveys and soil investigations to determine limitations that must be imposed on the grading operation related to slope stability, effect on adjacent properties and drainage patterns, measures for drainage and water removal, and vegetative treatment, etc.

Many municipalities and counties have regulations and design procedures already established for land grading and cut and fill slopes. Where these requirements exist, they shall be followed.

The plan must show existing and proposed contours of the area(s) to be graded. The plan shall also include practices for erosion control, slope stabilization, safe disposal of runoff water and drainage, such as waterways, lined ditches, reverse slope benches (include grade and cross section), grade stabilization structures, retaining walls, and surface and subsurface drains. The plan shall also include phasing of these practices. The following shall be incorporated into the plan:

1. Provisions shall be made to safely convey surface runoff to storm drains, protected outlets, or to stable water courses to ensure that surface runoff will not

damage slopes or other graded areas; see standards and specifications for Grassed Waterway, Diversion, or Grade Stabilization Structure.

2. Cut and fill slopes that are to be stabilized with grasses shall not be steeper than 2:1. When slopes exceed 2:1, special design and stabilization consideration are required and shall be adequately shown on the plans. (Note: Where the slope is to be mowed, the slope should be no steeper than 3:1, although 4:1 is preferred because of safety factors related to mowing steep slopes.)
3. Reverse slope benches or diversion shall be provided whenever the vertical interval (height) of any 2:1 slope exceeds 20 feet; for 3:1 slope it shall be increased to 30 feet and for 4:1 to 40 feet. Benches shall be located to divide the slope face as equally as possible and shall convey the water to a stable outlet. Soils, seeps, rock outcrops, etc., shall also be taken into consideration when designing benches.
 - A. Benches shall be a minimum of six feet wide to provide for ease of maintenance.
 - B. Benches shall be designed with a reverse slope of 6:1 or flatter to the toe of the upper slope and with a minimum of one foot in depth. Bench gradient to the outlet shall be between 2 percent and 3 percent, unless accompanied by appropriate design and computations.
 - C. The flow length within a bench shall not exceed 800 feet unless accompanied by appropriate design and computations; see Standard and Specifications for Diversion on page 3.9
4. Surface water shall be diverted from the face of all cut and/or fill slopes by the use of diversions, ditches and swales or conveyed downslope by the use of a designed structure, except where:
 - A. The face of the slope is or shall be stabilized and the face of all graded slopes shall be protected from surface runoff until they are stabilized.
 - B. The face of the slope shall not be subject to any concentrated flows of surface water such as from natural drainage ways, graded ditches, downspouts, etc.
 - C. The face of the slope will be protected by anchored stabilization matting, sod, gravel, riprap, or other stabilization method.

5. Cut slopes occurring in ripable rock shall be serrated as shown in Figure 4.9 on page 4.26. The serrations shall be made with conventional equipment as the excavation is made. Each step or serration shall be constructed on the contour and will have steps cut at nominal two-foot intervals with nominal three-foot horizontal shelves. These steps will vary depending on the slope ratio or the cut slope. The nominal slope line is 1 ½: 1. These steps will weather and act to hold moisture, lime, fertilizer, and seed thus producing a much quicker and longer-lived vegetative cover and better slope stabilization. Overland flow shall be diverted from the top of all serrated cut slopes and carried to a suitable outlet.
6. Subsurface drainage shall be provided where necessary to intercept seepage that would otherwise adversely affect slope stability or create excessively wet site conditions.
7. Slopes shall not be created so close to property lines as to endanger adjoining properties without adequately protecting such properties against sedimentation, erosion, slippage, settlement, subsidence, or other related damages.
8. Fill material shall be free of brush, rubbish, rocks, logs, stumps, building debris, and other objectionable material. It should be free of stones over two (2) inches in diameter where compacted by hand or mechanical tampers or over eight (8) inches in diameter where compacted by rollers or other equipment. Frozen material shall not be placed in the fill nor shall the fill material be placed on a frozen foundation.
9. Stockpiles, borrow areas, and spoil shall be shown on the plans and shall be subject to the provisions of this Standard and Specifications.
10. All disturbed areas shall be stabilized structurally or vegetatively in compliance with the Permanent Construction Area Planting Standard on page 4.42.
4. Areas to be filled shall be cleared, grubbed, and stripped of topsoil to remove trees, vegetation, roots, or other objectionable material.
5. Areas that are to be topsoiled shall be scarified to a minimum depth of four inches prior to placement of topsoil.
6. All fills shall be compacted as required to reduce erosion, slippage, settlement, subsidence, or other related problems. Fill intended to support buildings, structures, and conduits, etc., shall be compacted in accordance with local requirements or codes.
7. All fill shall be placed and compacted in layers not to exceed 9 inches in thickness.
8. Except for approved landfills or nonstructural fills, fill material shall be free of frozen particles, brush, roots, sod, or other foreign objectionable materials that would interfere with, or prevent, construction of satisfactory fills.
9. Frozen material or soft, mucky or highly compressible materials shall not be incorporated into fill slopes or structural fills.
10. Fill shall not be placed on saturated or frozen surfaces.
11. All benches shall be kept free of sediment during all phases of development.
12. Seeps or springs encountered during construction shall be handled in accordance with the Standard and Specification for Subsurface Drain on page 3.48 or other approved methods.
13. All graded areas shall be permanently stabilized immediately following finished grading.
14. Stockpiles, borrow areas, and spoil areas shall be shown on the plans and shall be subject to the provisions of this Standard and Specifications.

Construction Specifications

See Figures 4.9 and 4.10 for details.

1. All graded or disturbed areas, including slopes, shall be protected during clearing and construction in accordance with the erosion and sediment control plan until they are adequately stabilized.
2. All erosion and sediment control practices and measures shall be constructed, applied and maintained in accordance with the erosion and sediment control plan and these standards.
3. Topsoil required for the establishment of vegetation shall be stockpiled in amount necessary to complete finished grading of all exposed areas.



Figure 4.9
Typical Section of Serrated Cut Slope

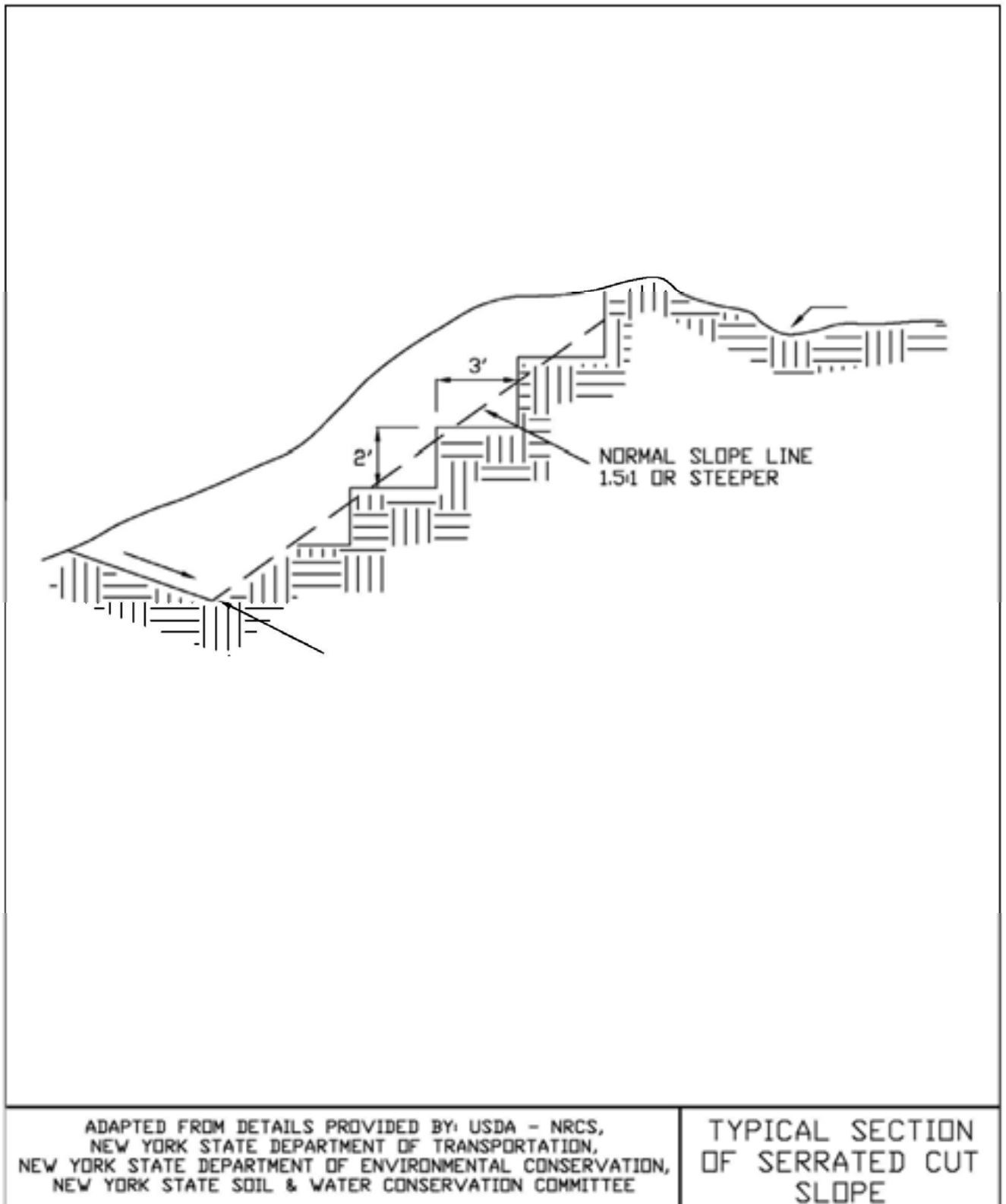

**Figure 4.10
Landgrading**

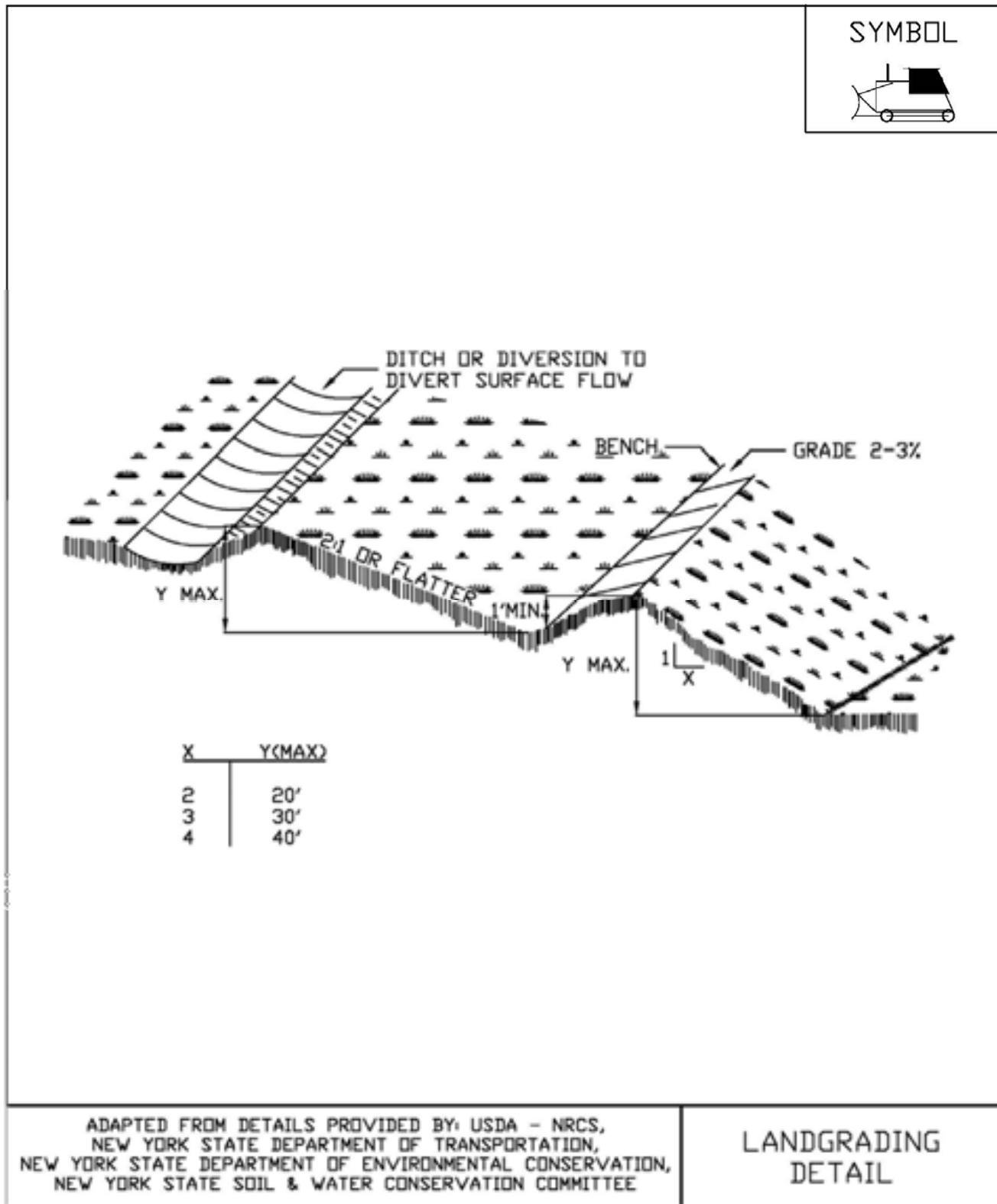

Figure 4.11
Landgrading - Construction Specifications

<u>CONSTRUCTION SPECIFICATIONS</u>	
<ol style="list-style-type: none"> 1. ALL GRADED OR DISTURBED AREAS INCLUDING SLOPES SHALL BE PROTECTED DURING CLEARING AND CONSTRUCTION IN ACCORDANCE WITH THE APPROVED EROSION AND SEDIMENT CONTROL PLAN UNTIL THEY ARE PERMANENTLY STABILIZED. 2. ALL SEDIMENT CONTROL PRACTICES AND MEASURES SHALL BE CONSTRUCTED, APPLIED AND MAINTAINED IN ACCORDANCE WITH THE APPROVED EROSION AND SEDIMENT CONTROL PLAN. 3. TOPSOIL REQUIRED FOR THE ESTABLISHMENT OF VEGETATION SHALL BE STOCKPILED IN AMOUNT NECESSARY TO COMPLETE FINISHED GRADING OF ALL EXPOSED AREAS. 4. AREAS TO BE FILLED SHALL BE CLEARED, GRUBBED, AND STRIPPED OF TOPSOIL TO REMOVE TREES, VEGETATION, ROOTS OR OTHER OBJECTIONABLE MATERIAL. 5. AREAS WHICH ARE TO BE TOPSOILED SHALL BE SCARIFIED TO A MINIMUM DEPTH OF FOUR INCHES PRIOR TO PLACEMENT OF TOPSOIL. 6. ALL FILLS SHALL BE COMPACTED AS REQUIRED TO REDUCE EROSION, SLIPPAGE, SETTLEMENT, SUBSIDENCE OR OTHER RELATED PROBLEMS. FILL INTENDED TO SUPPORT BUILDINGS, STRUCTURES AND CONDUITS, ETC. SHALL BE COMPACTED IN ACCORDANCE WITH LOCAL REQUIREMENTS OR CODES. 7. ALL FILL SHALL BE PLACED AND COMPACTED IN LAYERS NOT TO EXCEED 9 INCHES IN THICKNESS. 8. EXCEPT FOR APPROVED LANDFILLS, FILL MATERIAL SHALL BE FREE OF FROZEN PARTICLES, BRUSH, ROOTS, SOD, OR OTHER FOREIGN OR OTHER OBJECTIONABLE MATERIALS THAT WOULD INTERFERE WITH OR PREVENT CONSTRUCTION OF SATISFACTORY FILLS. 9. FROZEN MATERIALS OR SOFT, MUCKY OR HIGHLY COMPRESSIBLE MATERIALS SHALL NOT BE INCORPORATED IN FILLS. 10. FILL SHALL NOT BE PLACED ON SATURATED OR FROZEN SURFACES. 11. ALL BENCHES SHALL BE KEPT FREE OF SEDIMENT DURING ALL PHASES OF DEVELOPMENT. 12. SEEPS OR SPRINGS ENCOUNTERED DURING CONSTRUCTION SHALL BE HANDLED IN ACCORDANCE WITH THE STANDARD AND SPECIFICATION FOR SUBSURFACE DRAIN OR OTHER APPROVED METHOD. 13. ALL GRADED AREAS SHALL BE PERMANENTLY STABILIZED IMMEDIATELY FOLLOWING FINISHED GRADING. 14. STOCKPILES, BORROW AREAS AND SPOIL AREAS SHALL BE SHOWN ON THE PLANS AND SHALL BE SUBJECT TO THE PROVISIONS OF THIS STANDARD AND SPECIFICATION. 	
ADAPTED FROM DETAILS PROVIDED BY: USDA - NRCS, NEW YORK STATE DEPARTMENT OF TRANSPORTATION, NEW YORK STATE DEPARTMENT OF ENVIRONMENTAL CONSERVATION, NEW YORK STATE SOIL & WATER CONSERVATION COMMITTEE	LANDGRADING SPECIFICATIONS

STANDARD AND SPECIFICATIONS FOR SURFACE ROUGHENING



Definition & Scope

Roughening a bare soil surface whether through creating horizontal grooves across a slope, stair-stepping, or tracking with construction equipment to aid the establishment of vegetative cover from seed, to reduce runoff velocity and increase infiltration, and to reduce erosion and provide for trapping of sediment.

Conditions Where Practice Applies

All construction slopes require surface roughening to facilitate stabilization with vegetation, particularly slopes steeper than 3:1.

Design Criteria

There are many different methods to achieve a roughened soil surface on a slope. No specific design criteria is required. However, the selection of the appropriate method depends on the type of slope. Methods include tracking, grooving, and stair-stepping. Steepness, mowing requirements, and/or a cut or fill slope operation are all factors considered in choosing a roughening method.

Construction Specifications

1. Cut Slope, No mowing.
 - A. Stair-step grade or groove cut slopes with a gradient steeper than 3:1 (Figure 4.18).
 - B. Use stair-step grading on any erodible material soft enough to be ripped with a bulldozer. Slopes of soft rock with some soil are particularly suited to stair-step grading.

- C. Make the vertical cut distance less than the horizontal distance, and slightly slope the horizontal position of the “step” to the vertical wall.
- D. Do not make vertical cuts more than 2 feet in soft materials or 3 feet in rocky materials.

Grooving uses machinery to create a series of ridges and depressions that run perpendicular to the slope following the contour. Groove using any appropriate implement that can be safely operated on the slope, such as disks, tillers, spring harrows, or the teeth of a front-end loader bucket. Do not make the grooves less than 3 inches deep or more than 15 inches apart.

2. Fill Slope, No mowing

- A. Place fill to create slopes with a gradient no steeper than 2:1 in lifts 9 inches or less and properly compacted. Ensure the face of the slope consists of loose, uncompacted fill 4 to 6 inches deep. Use grooving as described above to roughen the slope, if necessary.
- B. Do not back blade or scrape the final slope face.

3. Cuts/Fills, Mowed Maintenance

- A. Make mowed slopes no steeper than 3:1.
- B. Roughen these areas to shallow grooves by normal tilling, disking, harrowing, or use of cultipacker-seeder. Make the final pass of such tillage equipment on the contour.
- C. Make grooves at least 1 inch deep and a maximum of 10 inches apart.
- D. Excessive roughness is undesirable where mowing is planned.

Tracking should be used primarily in sandy soils to avoid undue compaction of the soil surface. Tracking is generally not as effective as the other roughening methods described. (It has been used as a method to track down mulch.) Operate tracked machinery up and down the slope to leave horizontal depressions in the soil. Do not back-blade during the final grading operation.

Figure 4.18
Surface Roughening

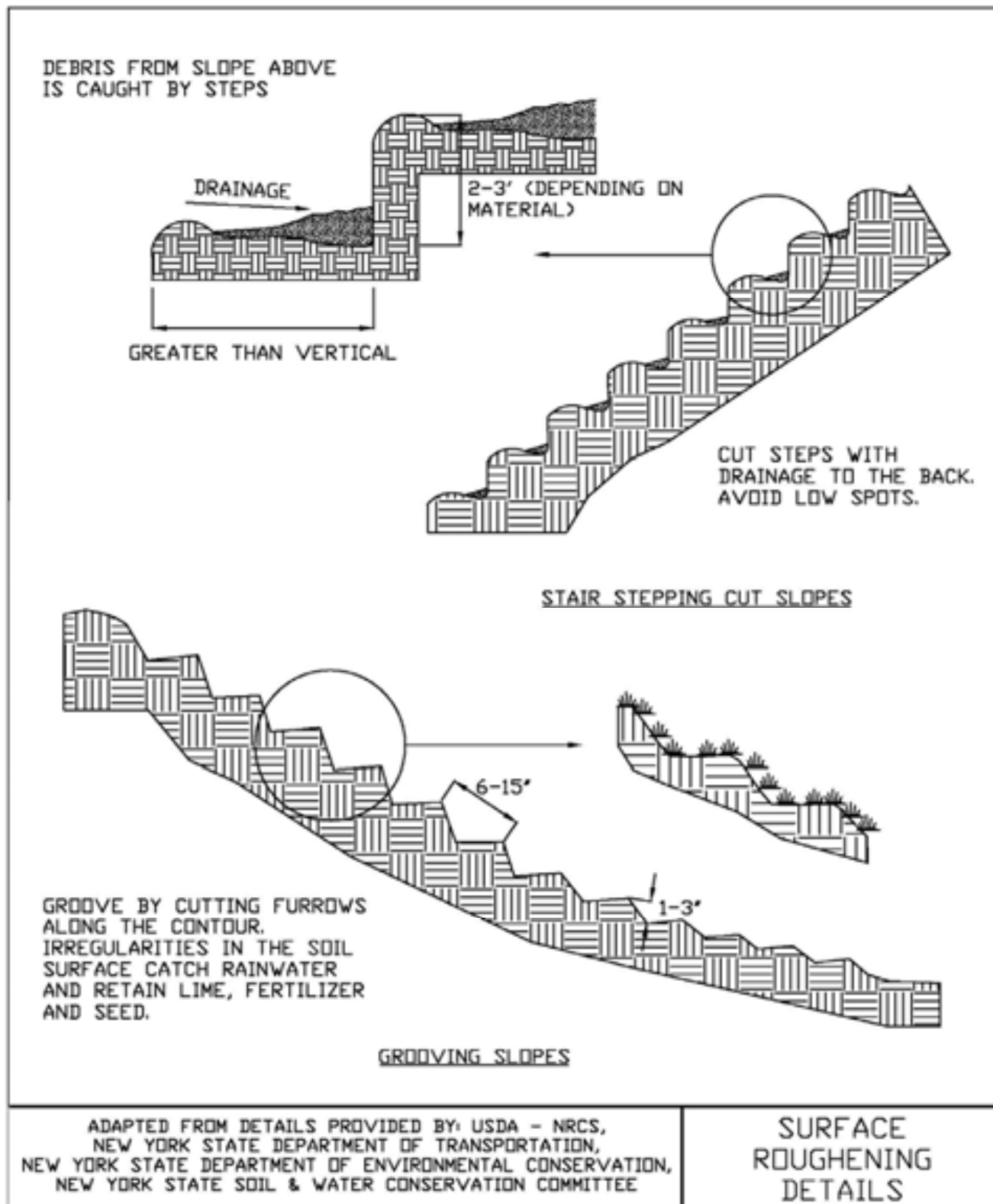

STANDARD AND SPECIFICATIONS FOR SOIL RESTORATION



Definition & Scope

The decompaction of areas of a development site or construction project where soils have been disturbed to recover the original properties and porosity of the soil; thus providing a sustainable growth medium for vegetation, reduction of runoff and filtering of pollutants from stormwater runoff.

Conditions Where Practice Applies

Soil restoration is to be applied to areas whose heavy construction traffic is done and final stabilization is to begin. This is generally applied in the cleanup, site restoration, and landscaping phase of construction followed by the permanent establishment of an appropriate ground cover to maintain the soil structure. Soil restoration measures should be applied over and adjacent to any runoff reduction practices to achieve design performance.



Design Criteria

1. Soil restoration areas will be designated on the plan views of areas to be disturbed.

2. Soil restoration will be completed in accordance with Table 4.6 on page 4.53.

Specification for Full Soil Restoration

During periods of relatively low to moderate subsoil moisture, the disturbed subsoils are returned to rough grade and the following Soil Restoration steps applied:

1. Apply 3 inches of compost over subsoil. The compost shall be well decomposed (matured at least 3 months), weed-free, organic matter. It shall be aerobically composted, possess no objectionable odors, and contain less than 1%, by dry weight, of man-made foreign matter. The physical parameters of the compost shall meet the standards listed in Table 5.2 - Compost Standards Table, except for "Particle Size" 100% will pass the 1/2" sieve. **Note: All biosolids compost produced in New York State (or approved for importation) must meet NYS DEC's 6 NYCRR Part 360 (Solid Waste Management Facilities) requirements. The Part 360 requirements are equal to or more stringent than 40 CFR Part 503 which ensure safe standards for pathogen reduction and heavy metals content.**



2. Till compost into subsoil to a depth of at least 12 inches using a cat-mounted ripper, tractor mounted disc, or tiller, to mix and circulate air and compost into the subsoil.
3. Rock-pick until uplifted stone/rock materials of four inches and larger size are cleaned off the site.
4. Apply topsoil to a depth of 6 inches.
5. Vegetate as required by the seeding plan. Use appropriate ground cover with deep roots to maintain the soil structure.
6. Topsoil may be manufactured as a mixture or a mineral component and organic material such as compost.

At the end of the project an inspector should be able to push a 3/8” metal bar 12 inches into the soil just with body weight. This should not be performed within the drip line of any existing trees or over utility installations that are within 24 inches of the surface.

Maintenance

Keep the site free of vehicular and foot traffic or other weight loads. Consider pedestrian footpaths.

**Table 4.6
Soil Restoration Requirements**

Type of Soil Disturbance	Soil Restoration Requirement		Comments/Examples
No soil disturbance	Restoration not permitted		Preservation of Natural Features
Minimal soil disturbance	Restoration not required		Clearing and grubbing
Areas where topsoil is stripped only - no change in grade	HSG A&B	HSG C&D	Protect area from any ongoing construction activities.
	Apply 6 inches of topsoil	Aerate* and apply 6 inches of topsoil	
Areas of cut or fill	HSG A&B	HSG C&D	
	Aerate* and apply 6 inches of topsoil	Apply full Soil Restoration**	
Heavy traffic areas on site (especially in a zone 5-25 feet around buildings but not within a 5 foot perimeter around foundation walls)	Apply full Soil Restoration (decompaction and compost enhancement)		
Areas where Runoff Reduction and/or Infiltration practices are applied	Restoration not required, but may be applied to enhance the reduction specified for appropriate practices.		Keep construction equipment from crossing these areas. To protect newly installed practice from any ongoing construction activities construct a single phase operation fence area
Redevelopment projects	Soil Restoration is required on redevelopment projects in areas where existing impervious area will be converted to pervious area.		
<p>* Aeration includes the use of machines such as tractor-drawn implements with coulters making a narrow slit in the soil, a roller with many spikes making indentations in the soil, or prongs which function like a mini-subsoiler. ** Per “Deep Ripping and De-compaction, DEC 2008”.</p>			

STANDARD AND SPECIFICATIONS FOR TOPSOILING



Definition & Scope

Spreading a specified quality and quantity of topsoil materials on graded or constructed subsoil areas to provide acceptable plant cover growing conditions, thereby reducing erosion; to reduce irrigation water needs; and to reduce the need for nitrogen fertilizer application.

Conditions Where Practice Applies

Topsoil is applied to subsoils that are droughty (low available moisture for plants), stony, slowly permeable, salty or extremely acid. It is also used to backfill around shrub and tree transplants. This standard does not apply to wetland soils.

Design Criteria

1. Preserve existing topsoil in place where possible, thereby reducing the need for added topsoil.
2. Conserve by stockpiling topsoil and friable fine textured subsoils that must be stripped from the excavated site and applied after final grading where vegetation will be established. Topsoil stockpiles must be stabilized. Stockpile surfaces can be stabilized by vegetation, geotextile or plastic covers. This can be aided by orientating the stockpile lengthwise into prevailing winds.
3. Refer to USDA Natural Resource Conservation Service soil surveys or soil interpretation record sheets for further soil texture information for selecting appropriate design topsoil depths.

Site Preparation

1. As needed, install erosion and sediment control practices such as diversions, channels, sediment traps, and stabilizing measures, or maintain if already installed.
2. Complete rough grading and final grade, allowing for depth of topsoil to be added.
3. Scarify all compact, slowly permeable, medium and fine textured subsoil areas. Scarify at approximately right angles to the slope direction in soil areas that are steeper than 5 percent. Areas that have been overly compacted shall be decompact in accordance with the Soil Restoration Standard.
4. Remove refuse, woody plant parts, stones over 3 inches in diameter, and other litter.

Topsoil Materials

1. Topsoil shall have at least 6 percent by weight of fine textured stable organic material, and no greater than 20 percent. Muck soil shall not be considered topsoil.
2. Topsoil shall have not less than 20 percent fine textured material (passing the NO. 200 sieve) and not more than 15 percent clay.
3. Topsoil treated with soil sterilants or herbicides shall be so identified to the purchaser.
4. Topsoil shall be relatively free of stones over 1 1/2 inches in diameter, trash, noxious weeds such as nut sedge and quackgrass, and will have less than 10 percent gravel.
5. Topsoil containing soluble salts greater than 500 parts per million shall not be used.
6. Topsoil may be manufactured as a mixture of a mineral component and organic material such as compost.

Application and Grading

1. Topsoil shall be distributed to a uniform depth over the area. It shall not be placed when it is partly frozen, muddy, or on frozen slopes or over ice, snow, or standing water puddles.
2. Topsoil placed and graded on slopes steeper than 5 percent shall be promptly fertilized, seeded, mulched, and stabilized by “tracking” with suitable equipment.
3. Apply topsoil in the amounts shown in Table 4.7 below:

Table 4.7 - Topsoil Application Depth		
Site Conditions	Intended Use	Minimum Topsoil Depth
1. Deep sand or loamy sand	Mowed lawn	6 in.
	Tall legumes, unmowed	2 in.
	Tall grass, unmowed	1 in.
2. Deep sandy loam	Mowed lawn	5 in.
	Tall legumes, unmowed	2 in.
	Tall grass, unmowed	none
3. Six inches or more: silt loam, clay loam, loam, or silt	Mowed lawn	4 in.
	Tall legumes, unmowed	1 in.
	Tall grass, unmowed	1 in.

STANDARD AND SPECIFICATIONS FOR MULCHING



Definition and Scope

Applying coarse plant residue or chips, or other suitable materials, to cover the soil surface to provide initial erosion control while a seeding or shrub planting is establishing. Mulch will conserve moisture and modify the surface soil temperature and reduce fluctuation of both. Mulch will prevent soil surface crusting and aid in weed control. Mulch can also be used alone for temporary stabilization in non-growing months. Use of stone as a mulch could be more permanent and should not be limited to non-growing months.

Conditions Where Practice Applies

On soils subject to erosion and on new seedlings and shrub plantings. Mulch is useful on soils with low infiltration rates by retarding runoff.

Criteria

Site preparation prior to mulching requires the installation of necessary erosion control or water management practices and drainage systems.

Slope, grade and smooth the site to fit needs of selected mulch products.

Remove all undesirable stones and other debris to meet the needs of the anticipated land use and maintenance required.

Apply mulch after soil amendments and planting is accomplished or simultaneously if hydroseeding is used.

Select appropriate mulch material and application rate or material needs. Hay mulch shall not be used in wetlands or in areas of permanent seeding. Clean straw mulch is preferred alternative in wetland application. Determine local availability.

Select appropriate mulch anchoring material.

NOTE: The best combination for grass/legume establishment is straw (cereal grain) mulch applied at 2 ton/acre (90 lbs./1000sq.ft.) and anchored with wood fiber mulch (hydromulch) at 500 – 750 lbs./acre (11 – 17 lbs./1000 sq. ft.). The wood fiber mulch must be applied through a hydroseeder immediately after mulching.



Table 4.2
Guide to Mulch Materials, Rates, and Uses

Mulch Material	Quality Standards	per 1000 Sq. Ft.	per Acre	Depth of Application	Remarks
Wood chips or shavings	Air-dried. Free of objectionable coarse material	500-900 lbs.	10-20 tons	2-7"	Used primarily around shrub and tree plantings and recreation trails to inhibit weed competition. Resistant to wind blowing. Decomposes slowly.
Wood fiber cellulose (partly digested wood fibers)	Made from natural wood usually with green dye and dispersing agent	50 lbs.	2,000 lbs.	—	Apply with hydromulcher. No tie down required. Less erosion control provided than 2 tons of hay or straw.
Gravel, Crushed Stone or Slag	Washed; Size 2B or 3A—1 1/2"	9 cu. yds.	405 cu. yds.	3"	Excellent mulch for short slopes and around plants and ornaments. Use 2B where subject to traffic. (Approximately 2,000 lbs./cu. yd.). Frequently used over filter fabric for better weed control.
Hay or Straw	Air-dried; free of undesirable seeds & coarse materials	90-100 lbs. 2-3 bales	2 tons (100-120 bales)	cover about 90% surface	Use small grain straw where mulch is maintained for more than three months. Subject to wind blowing unless anchored. Most commonly used mulching material. Provides the best micro-environment for germinating seeds.
Jute twisted yarn	Undyed, unbleached plain weave. Warp 78 ends/yd., Weft 41 ends/yd. 60-90 lbs./roll	48" x 50 yds. or 48" x 75 yds.	—	—	Use without additional mulch. Tie down as per manufacturers specifications. Good for center line of concentrated water flow.
Excelsior wood fiber mats	Interlocking web of excelsior fibers with photodegradable plastic netting	4' x 112.5' or 8' x 112.5'	—	—	Use without additional mulch. Excellent for seeding establishment. Anchor as per manufacturers specifications. Approximately 72 lbs./roll for excelsior with plastic on both sides. Use two sided plastic for centerline of waterways.
Straw or coconut fiber, or combination	Photodegradable plastic net on one or two sides	Most are 6.5 ft. x 3.5 ft.	81 rolls	—	Designed to tolerate higher velocity water flow, centerlines of waterways, 60 sq. yds. per roll.

Table 4.3
Mulch Anchoring Guide

Anchoring Method or Material	Kind of Mulch to be Anchored	How to Apply
1. Peg and Twine	Hay or straw	After mulching, divide areas into blocks approximately 1 sq. yd. in size. Drive 4-6 pegs per block to within 2" to 3" of soil surface. Secure mulch to surface by stretching twine between pegs in criss-cross pattern on each block. Secure twine around each peg with 2 or more tight turns. Drive pegs flush with soil. Driving stakes into ground tightens the twine.
2. Mulch netting	Hay or straw	Staple the light-weight paper, jute, wood fiber, or plastic nettings to soil surface according to manufacturer's recommendations. Should be biodegradable. Most products are not suitable for foot traffic.
3. Wood cellulose fiber	Hay or straw	Apply with hydroseeder immediately after mulching. Use 500 lbs. wood fiber per acre. Some products contain an adhesive material ("tackifier"), possibly advantageous.
4. Mulch anchoring tool	Hay or straw	Apply mulch and pull a mulch anchoring tool (blunt, straight discs) over mulch as near to the contour as possible. Mulch material should be "tucked" into soil surface about 3".
5. Tackifier	Hay or straw	Mix and apply polymeric and gum tackifiers according to manufacturer's instructions. Avoid application during rain. A 24-hour curing period and a soil temperature higher than 45 ^o Fahrenheit are required.

STANDARD AND SPECIFICATIONS FOR TREES, SHRUBS, AND VINES



Definition & Scope

Establishing trees, shrubs, and vines or selectively reducing stand density and trimming woody plants to protect the soil and plant resources, improve an area for recreation and increase the attractiveness and usefulness of areas.

Conditions Where Practice Applies

On any area planned for recreation or landscape use such as yard areas, leisure areas, picnic areas, and park lands providing outdoor recreational opportunities.

Criteria and Specifications

1. Planting nursery stock

A. Select species to serve the intended purpose. See Appendix G, Table G.1, “Trees Suitable for Landscape and Conservation Plantings in New York.” Where planting of trees is to be done in recreation areas, use those species resistant to compaction listed in Table G.2, “Susceptibility of Tree Species to Compaction” whenever possible.

B. Plant Materials

1) Plants shall conform to the species, variety, size, number, and conditions as stated in a conservation plan or on a plant list shown on landscape drawings. “American Standard for Nursery Stock,” by American Association of Nurserymen, shall be used to develop the plant list for landscape drawings and to check quality of plant materials.

2) Durable, legible labels with the scientific and common name and cultivar shall be securely

attached to plants, bundles of seedlings, containers, and/or flats.

C. Plant Protection

Prior to delivery, the trunk, branches, and foliage of the plants shall be sprayed with non-toxic antidesiccant, applied according to the manufacturer’s recommendations. This does not apply to state nursery seedlings.

D. Planting Time

Deciduous trees and shrubs: April 1 to June 1 and October 15 to December 15. Evergreen trees and shrubs: April 1 to June 1 and September 1 to November 15.

E. Spacing

Plant all trees and shrubs well back from buildings to allow for mature crown size. The following are guides for planning:

Large Trees	50-60 feet apart
Small Trees	20-30 feet apart
Columnar Species	6-8 feet apart
Hedges	1-4 feet apart
Shrubs	For clumps, plan spacing so mature shrubs will be touching or overlapping by only 1 or 2 feet

F. Site Preparation

1) Individual sites for planting seedlings can be prepared by scalping the sod away from a four foot square area where the seedling is to be planted.

2) All planting beds shall be cultivated to a depth of 8 inches, or chemically treated for weed control. Remove objectionable objects that will interfere with maintenance of site.

G. Planting

1) Plants shall be located as shown on plans and/or drawings and, where necessary, located on the site by stakes, flags or other means.

2) Prior to planting, remove galvanized wire basket securing root ball, untie and roll down burlap covering from around the stem.

3) The plants shall be set upright in holes as illustrated in Figure G.1 in Appendix G.

4) All plants shall be thoroughly watered on the same day of planting. Plants that have settled shall be reset to grade.

approximate weight of soil ball that must be moved with each size plant.

D. Plant and maintain as described above for nursery stock.

H. Wrapping

Immediately after planting, wrap deciduous tree trunks from the bottom to the first limb with a 4 inch wide bituminous impregnated, insect resistant tape or paper manufactured for that purpose. Tie with jute (bag strings) at top and bottom. The wrap should be removed per nursery recommendations.

I. Mulching

Mulch the disturbed area around individual trees and shrubs with a 2-3" layer of wood chips. Pull wood chips 1 inch away from the base of shrubs to avoid fungus development.

J. Pruning

After planting, prune to remove injured twigs and branches. The natural shape of the plant should not be changed.

K. Cleanup and Maintenance

1) After all work is complete, all excess soil, peat moss, debris, etc., shall be removed from the site.

2) Water plants two weeks after planting. For two years, water plants every two weeks during dry periods, which exceed three weeks without a good soaking rain, or water as needed in accordance with local conditions. Shrubs may require 5 to 10 gallons and trees, 20 to 30 gallons for each watering.

3) Remove trunk wrap per nursery recommendation.

2. Transplanting "Wild" Stock

Successful transplanting of wild stock will require heavy equipment and considerable labor as a large weight of soil must be moved with the roots.

A. Select trees and shrubs with good form and full crowns.

B. Transplant only when plants are dormant and soil is moist. Wrap soil ball with burlap to prevent soil from separating from roots.

C. Table 4.8 shows minimum diameter and

PRUNING AND THINNING

Use	Cleared Width Each Side of Trail Tread (ft.)	Cleared Height (ft.)
TRAILS		
Hiking	1	8
Bicycle	2	10
Motorbike	2	10
Horse	2	12
X-Country Ski	Total: 3-12	12 ¹
Snowmobile	Total: 6-12	12 ¹
PICNIC & CAMPING AREAS		
Campfire/Grill	10 ft. diam.	15
¹ Includes allowance for snow depth and snow load on branches		

1. Pruning

A. Remove trees, limbs, and limb stubs to the above widths and heights specified for the intended use.

B. Remove dead, diseased, or dying limbs that may fall.

C. Do not remove more than one-third of the live crown of a tree in a year.

D. Cut limbs flush to the branch bark ridge.

E. Use the 3 or 4 cut pruning method on all branches over 2 inches in diameter: First cut about one-third the way through the underside of the limb (about 6-12 inches from the tree trunk). Then (approximately an inch further out) make a second cut through the limb from the upper side. When the branch is removed, there is no splintering of the main tree trunk. Remove the stub. If the branch is larger than 5-6 inches in diameter, use the four cut system. Cuts 1 and 2 remain the same and cut 3 should be from the underside of the limb, on the outside of the branch collar. Cut 4 should be from the top and in alignment with the 3rd cut. Cut 3 should be 1/4 to 1/3 the way through the limb. This will prevent the bark from peeling down the trunk. Do not paint the cut surface.

2. Thinning

- A. Remove dead, diseased, dying, poorly anchored, or ice damaged trees that pose a hazard to recreationists or that interfere with intended use.
- B. To maintain grass cover in a wooded area, thin according to formula $D \times 3$ (average diameter of the trunk of overstory trees, in inches, times three—the answer is the spacing between trees to be left, in feet). For example, for trees with average diameter of 6 inches, spacing after thinning should leave trees 18 feet apart on average. Crown cover after thinning should be about 50 percent.
- C. Selectively thin as needed to favor those trees that are most “resistant” to compaction around their roots. See Table G.2, “Susceptibility of Tree Species to Compaction” in Appendix G. If the soil on the site is naturally well drained, those species in the “intermediate” group may also be favored.

Table 4.8
Size and Weight of Earth Ball Required to Transplant Wild Stock

Caliper ¹ (Inches)	Shade Trees (Maple, Ash, Oak, Birch, etc.)		Small Trees & Shrubs (Crabapple, Thornapple, Viburnum, Dogwood, etc.)		
	Minimum Diameter Ball (Inches)	Weight of Ball (lbs.)	Up to 6 ft. Height — 6 ft. and Caliper ¹	Minimum Diameter Ball (Inches)	Weight of Ball (lbs.)
1/2	14	88	2	12	55
3/4	16	130	3	14	88
1	18	186	4	16	130
1-1/4	20	227	5	18	186
1-1/2	22	302	3/4	18	186
1-3/4	24	390	1	20	227
2	28	621	1-1/2	22	302
3	32	836	1-3/4	24	390
3-1/2	38	1,400	2	28	621
4	42	1,887	2-1/2	32	836
			3	38	1,400

¹Caliper is a diameter measurement of trees at a height of 6 inches above the ground.

STANDARD AND SPECIFICATIONS FOR VEGETATING WATERWAYS



Definition & Scope

Waterways are a **permanently** constructed conveyance channel, shaped or graded. They are vegetated for the safe transport of excess surface water from construction sites and urban areas without damage from erosion.

Conditions Where Practice Applies

This standard applies to vegetating waterways and similar water carrying structures.

Supplemental measures may be required with this practice. These may include: subsurface drainage to permit the growth of suitable vegetation and to eliminate wet spots; a section stabilized with asphalt, stone, or other suitable means; or additional storm drains to handle snowmelt or storm runoff.

Retardance factors for determining waterway dimensions are shown in Table 3.1 on page 3.10 and “Maximum Permissible Velocities for Selected Grass and Legume Mixtures” (See Table 4.10 on page 4.79).

Design Criteria

Waterways or outlets shall be protected against erosion by vegetative means as soon after construction as practical. Vegetation must be well established before diversions or other channels are outletted into them. Consideration should be given to the use of turf reinforcement mats, excelsior matting, other rolled erosion control products, or sodding of channels to provide erosion protection as soon after construction as possible. It is strongly recommended that the center line of the waterway be protected with one of the above materials to avoid center gullies and to protect seedlings from erosion before establishment.

1. Liming, fertilizing, and seedbed preparation.

- A. Lime to pH 6.5.
 - B. **The soil should be tested to determine the amounts of amendments needed.** If the soil must be fertilized before results of a soil test can be obtained to determine fertilizer needs, apply commercial fertilizer at 1.0 lbs/1,000 sq. ft. of N, P₂O₅, and K₂O.
 - C. Lime and fertilizer shall be mixed thoroughly into the seedbed during preparation.
 - D. Channels, except for paved section, shall have at least 4 inches of topsoil.
 - E. Remove stones and other obstructions that will hinder maintenance.
2. Timing of Seeding.
- A. Early spring and late August are best.
 - B. Temporary cover to protect from erosion is recommended during periods when seedings may fail.

3. Seed Mixtures:

Mixtures	Rate per Acre (lbs)	Rate per 1,000 sq. ft. (lbs)
A. White clover or ladino clover ¹	8	0.20
Smooth brome grass	20	0.45
Creeping red fescue ²	2	0.05
Total	30	0.70

OR

B. Smooth brome grass ³	25	0.60
Creeping red fescue	20	0.50
Perennial ryegrass	10	0.20
Total	55	1.30

¹ Inoculate with appropriate inoculum immediately prior to seeding. Ladino or birdsfoot trefoil may be substituted for common white clover and seeded at the same rate.

² Perennial ryegrass may be substituted for the creeping red fescue but increase seeding rate to 5 lbs/acre (0.1 lb/1,000 sq. ft).

³ Use this mixture in areas which are mowed frequently. Common white clover may be added if desired and seeded at 8 lbs/acre (0.2 lb/1,000 sq. ft.)

4. Seeding

Select the appropriate seed mixture and apply uniformly over the area. Rolling or cultipacking across the waterway is desirable.

Waterway centers or crucial areas may be sodded. Refer to the standard and specification for Stabilization with Sod. Be sure sod is securely anchored using staples or stakes.

5. Mulching

All seeded areas will be mulched. Channels more than 300 feet long, and/or where the slope is 5 percent or more, must have the mulch securely anchored. Refer to the standard and specifications for Mulching for details.

6. Maintenance

Fertilize, lime, and mow as needed to maintain dense protective vegetative cover.

Waterways shall not be used for roadways.

If rills develop in the centerline of a waterway, prompt attention is required to avoid the formation of gullies. Either stone and/or compacted soil fill with excelsior or filter fabric as necessary may be used during the establishment phase. See Figure 4.25, Rill Maintenance Measures. Spacing between rill maintenance barriers shall not exceed 100 feet.

Table 4.10
Maximum Permissible Velocities for Selected Seed Mixtures

Cover	Slope Range ² (%)	Permissible Velocity ¹	
		Erosion-resistant Soils (ft. per sec.) K=0.10 - 0.35 ³	Easily Eroded Soils (ft. per sec.) K=0.36 - 0.80
Smooth Bromegrass	0-5	7	5
Hard Fescue	5-10	6	4
	Over 10	5	3
Grass Mixtures	² 0-5	5	4
	5-10	4	3
White/Red Clover	⁴ 0-5	3.5	2.5
Alfalfa			
Red Fescue			
¹ Use velocities exceeding 5 feet per second only where good covers and proper maintenance can be obtained. ² Do not use on slopes steeper than 10 percent except for vegetated side slopes in combination with a stone, concrete, or highly resistant vegetative center section. ³ K is the soil erodibility factor used in the Revised Universal Soil Loss Equation. Visit Appendix A or consult the appropriate USDA-NRCS technical guide for K values for New York State soils. ⁴ Do not use on slopes steeper than 5 percent except for vegetated side slopes in combination with a stone, concrete, or highly resistant vegetative center section. ⁵ Annuals - use on mild slopes or as temporary protection until permanent covers are established. ⁶ Use on slopes steeper than 5 percent is not recommended.			

Figure 4.25
Rill Maintenance Measures

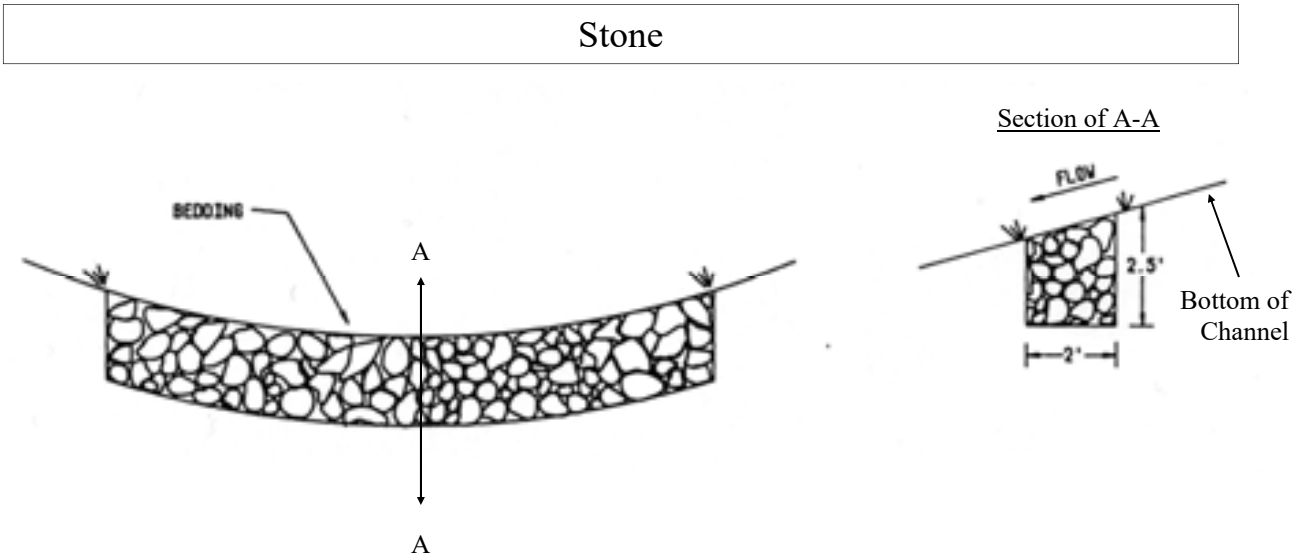
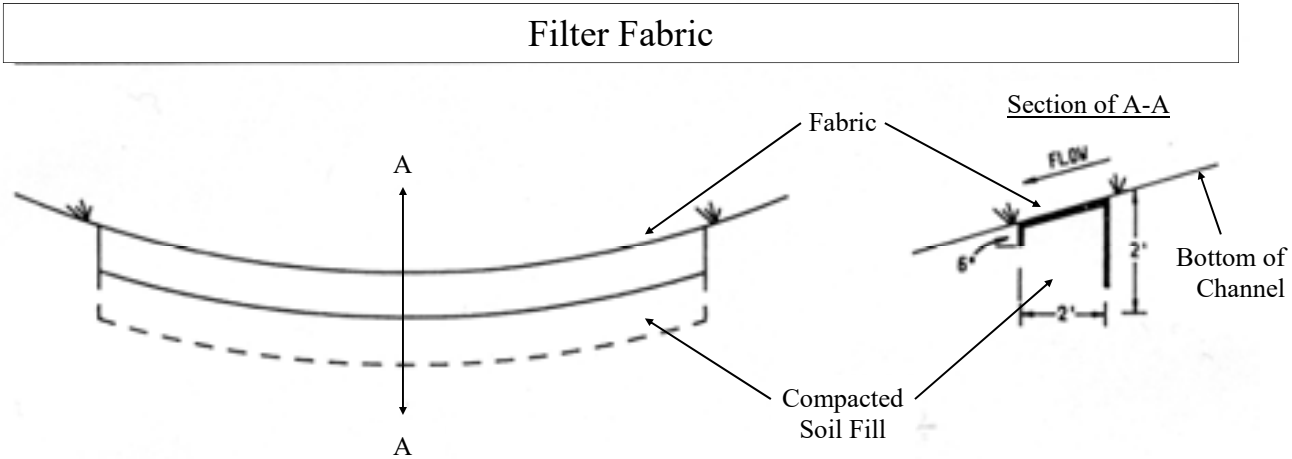

STANDARD AND SPECIFICATIONS FOR ROCK OUTLET PROTECTION



Definition & Scope

A **permanent** section of rock protection placed at the outlet end of the culverts, conduits, or channels to reduce the depth, velocity, and energy of water, such that the flow will not erode the receiving downstream reach.

Conditions Where Practice Applies

This practice applies where discharge velocities and energies at the outlets of culverts, conduits, or channels are sufficient to erode the next downstream reach. This applies to:

1. Culvert outlets of all types.
2. Pipe conduits from all sediment basins, dry storm water ponds, and permanent type ponds.
3. New channels constructed as outlets for culverts and conduits.

Design Criteria

The design of rock outlet protection depends entirely on the location. Pipe outlet at the top of cuts or on slopes steeper than 10 percent, cannot be protected by rock aprons or riprap sections due to re-concentration of flows and high velocities encountered after the flow leaves the apron.

Many counties and state agencies have regulations and design procedures already established for dimensions, type and size of materials, and locations where outlet protection is required. Where these requirements exist, they shall be followed.

Tailwater Depth

The depth of tailwater immediately below the pipe outlet

must be determined for the design capacity of the pipe. If the tailwater depth is less than half the diameter of the outlet pipe, and the receiving stream is wide enough to accept divergence of the flow, it shall be classified as a Minimum Tailwater Condition; see Figure 3.16 on page 3.42 as an example. If the tailwater depth is greater than half the pipe diameter and the receiving stream will continue to confine the flow, it shall be classified as a Maximum Tailwater Condition; see Figure 3.17 on page 3.43 as an example. Pipes which outlet onto flat areas with no defined channel may be assumed to have a Minimum Tailwater Condition; see Figure 3.16 on page 3.42 as an example.

Apron Size

The apron length and width shall be determined from the curves according to the tailwater conditions:

Minimum Tailwater – Use Figure 3.16 on page 3.42

Maximum Tailwater – Use Figure 3.17 on page 3.43

If the pipe discharges directly into a well defined channel, the apron shall extend across the channel bottom and up the channel banks to an elevation one foot above the maximum tailwater depth or to the top of the bank, whichever is less.

The upstream end of the apron, adjacent to the pipe, shall have a width two (2) times the diameter of the outlet pipe, or conform to pipe end section if used.

Bottom Grade

The outlet protection apron shall be constructed with no slope along its length. There shall be no overfall at the end of the apron. The elevation of the downstream end of the apron shall be equal to the elevation of the receiving channel or adjacent ground.

Alignment

The outlet protection apron shall be located so that there are no bends in the horizontal alignment.

Materials

The outlet protection may be done using rock riprap, grouted riprap, or gabions. Outlets constructed on the bank of a stream or wetland shall not use grouted rip-rap, gabions or concrete.

Riprap shall be composed of a well-graded mixture of rock size so that 50 percent of the pieces, by weight, shall be larger than the d_{50} size determined by using the charts. A

well-graded mixture, as used herein, is defined as a mixture composed primarily of larger rock sizes, but with a sufficient mixture of other sizes to fill the smaller voids between the rocks. The diameter of the largest rock size in such a mixture shall be 1.5 times the d_{50} size.

Thickness

The minimum thickness of the riprap layer shall be 1.5 times the maximum rock diameter for d_{50} of 15 inches or less; and 1.2 times the maximum rock size for d_{50} greater than 15 inches. The following chart lists some examples:

D_{50} (inches)	d_{max} (inches)	Minimum Blanket Thick- ness (inches)
4	6	9
6	9	14
9	14	20
12	18	27
15	22	32
18	27	32
21	32	38
24	36	43

Rock Quality

Rock for riprap shall consist of field rock or rough unhewn quarry rock. The rock shall be hard and angular and of a quality that will not disintegrate on exposure to water or weathering. The specific gravity of the individual rocks shall be at least 2.5.

Filter

A filter is a layer of material placed between the riprap and the underlying soil surface to prevent soil movement into and through the riprap. Riprap shall have a filter placed under it in all cases.

A filter can be of two general forms: a gravel layer or a plastic filter cloth. The plastic filter cloth can be woven or non-woven monofilament yarns, and shall meet these base requirements: thickness 20-60 mils, grab strength 90-120 lbs; and shall conform to ASTM D-1777 and ASTM D-1682.

Gravel filter blanket, when used, shall be designed by comparing particle sizes of the overlying material and the base material. Design criteria are available in Standard and Specification for Anchored Slope and Channel Stabilization on page 4.7.

Gabions

Gabions shall be made of hexagonal triple twist mesh with heavily galvanized steel wire. The maximum linear dimension of the mesh opening shall not exceed 4 ½ inches and the area of the mesh opening shall not exceed 10 square inches.

Gabions shall be fabricated in such a manner that the sides, ends, and lid can be assembled at the construction site into a rectangular basket of the specified sizes. Gabions shall be of single unit construction and shall be installed according to manufacturer's recommendations.

The area on which the gabion is to be installed shall be graded as shown on the drawings. Foundation conditions shall be the same as for placing rock riprap, and filter cloth shall be placed under all gabions. Where necessary, key, or tie, the structure into the bank to prevent undermining of the main gabion structure.

Maintenance

Once a riprap outlet has been installed, the maintenance needs are very low. It should be inspected after high flows for evidence of scour beneath the riprap or for dislodged rocks. Repairs should be made immediately.

Design Procedure

1. Investigate the downstream channel to assure that nonerosive velocities can be maintained.
2. Determine the tailwater condition at the outlet to establish which curve to use.
3. Use the appropriate chart with the design discharge to determine the riprap size and apron length required. It is noted that references to pipe diameters in the charts are based on full flow. For other than full pipe flow, the parameters of depth of flow and velocity must be used to adjust the design discharges.
4. Calculate apron width at the downstream end if a flare section is to be employed.

Design Examples are demonstrated in Appendix B.

Construction Specifications

1. The subgrade for the filter, riprap, or gabion shall be prepared to the required lines and grades. Any fill required in the subgrade shall be compacted to a density of approximately that of the surrounding undisturbed material.
2. The rock or gravel shall conform to the specified grad-

ing limits when installed respectively in the riprap or filter.

3. Filter cloth shall be protected from punching, cutting, or tearing. Any damage other than an occasional small hole shall be repaired by placing another piece of cloth over the damaged part or by completely replacing the cloth. All overlaps, whether for repairs or for joining two pieces of cloth shall be a minimum of one foot.
4. Rock for the riprap or gabion outlets may be placed by equipment. Both shall each be constructed to the full course thickness in one operation and in such a manner as to avoid displacement of underlying materials. The rock for riprap or gabion outlets shall be delivered and placed in a manner that will ensure that it is reasonably homogenous with the smaller rocks and spalls filling the voids between the larger rocks. Riprap shall be placed in a manner to prevent damage to the filter blanket or filter cloth. Hand placement will be required to the extent necessary to prevent damage to the permanent works.

Figure 3.16
Outlet Protection Design—Minimum Tailwater Condition Chart
(Design of Outlet Protection from a Round Pipe Flowing Full,
Minimum Tailwater Condition: $T_w < 0.5D_o$) (USDA - NRCS)

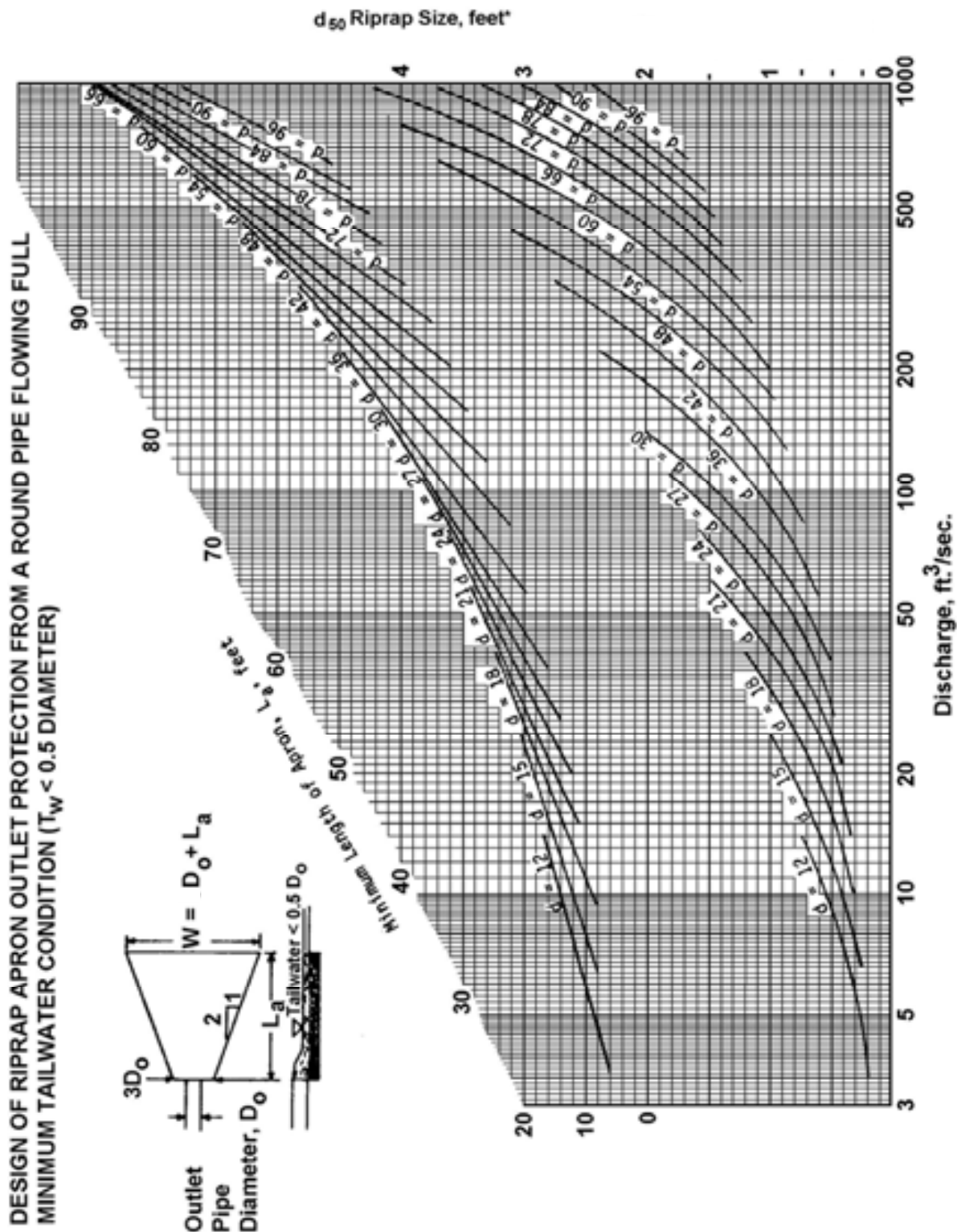

* For discharge velocities exceeding Maximum Allowable for Riprap indicated, increase d₅₀ stone size and/or provide velocity reduction device.

Figure 3.17
Outlet Protection Design—Maximum Tailwater Condition Chart
(Design of Outlet Protection from a Round Pipe Flowing Full,
Maximum Tailwater Condition: $T_w \geq 0.5D_o$) (USDA - NRCS)

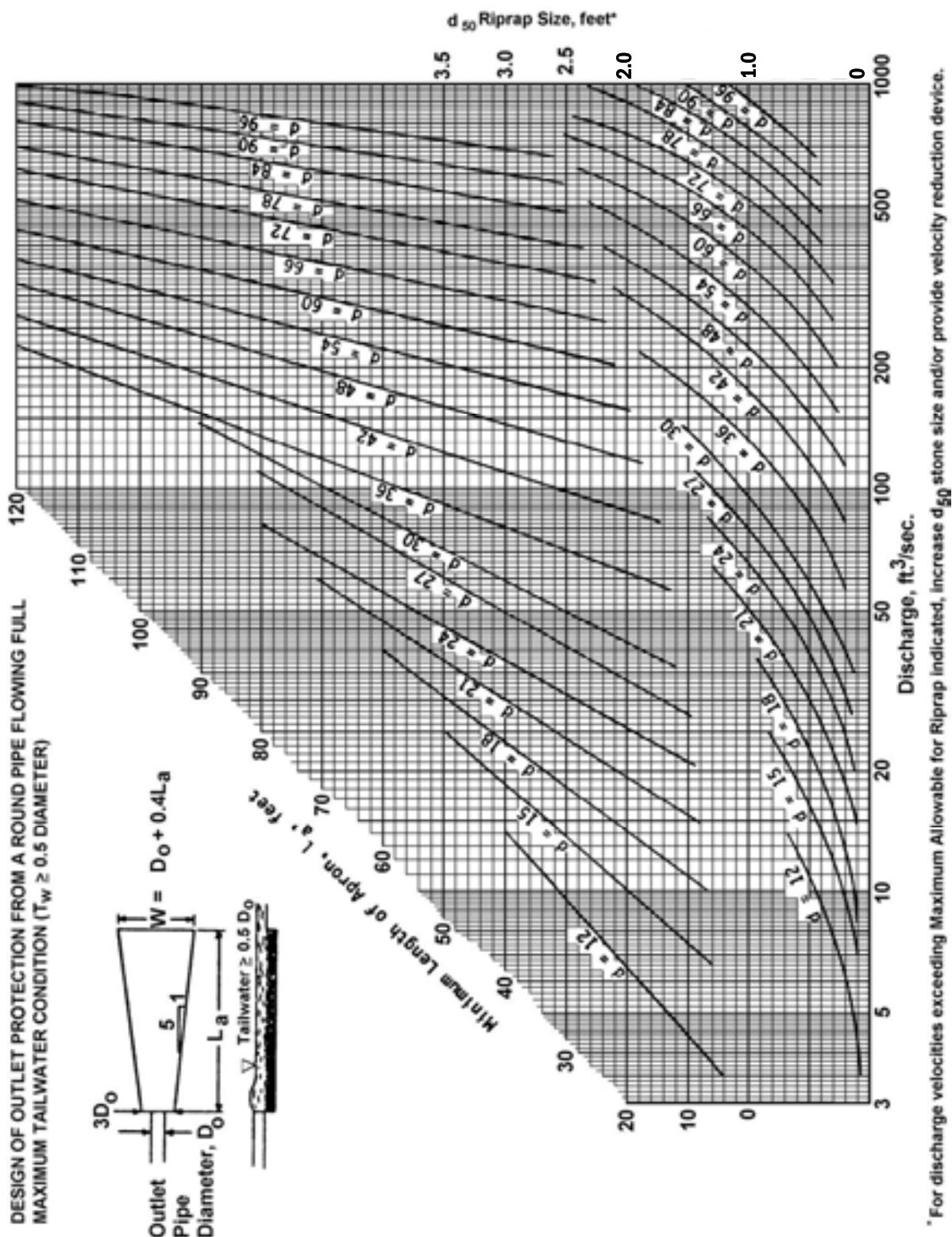

**Figure 3.18
Riprap Outlet Protection Detail (1)**

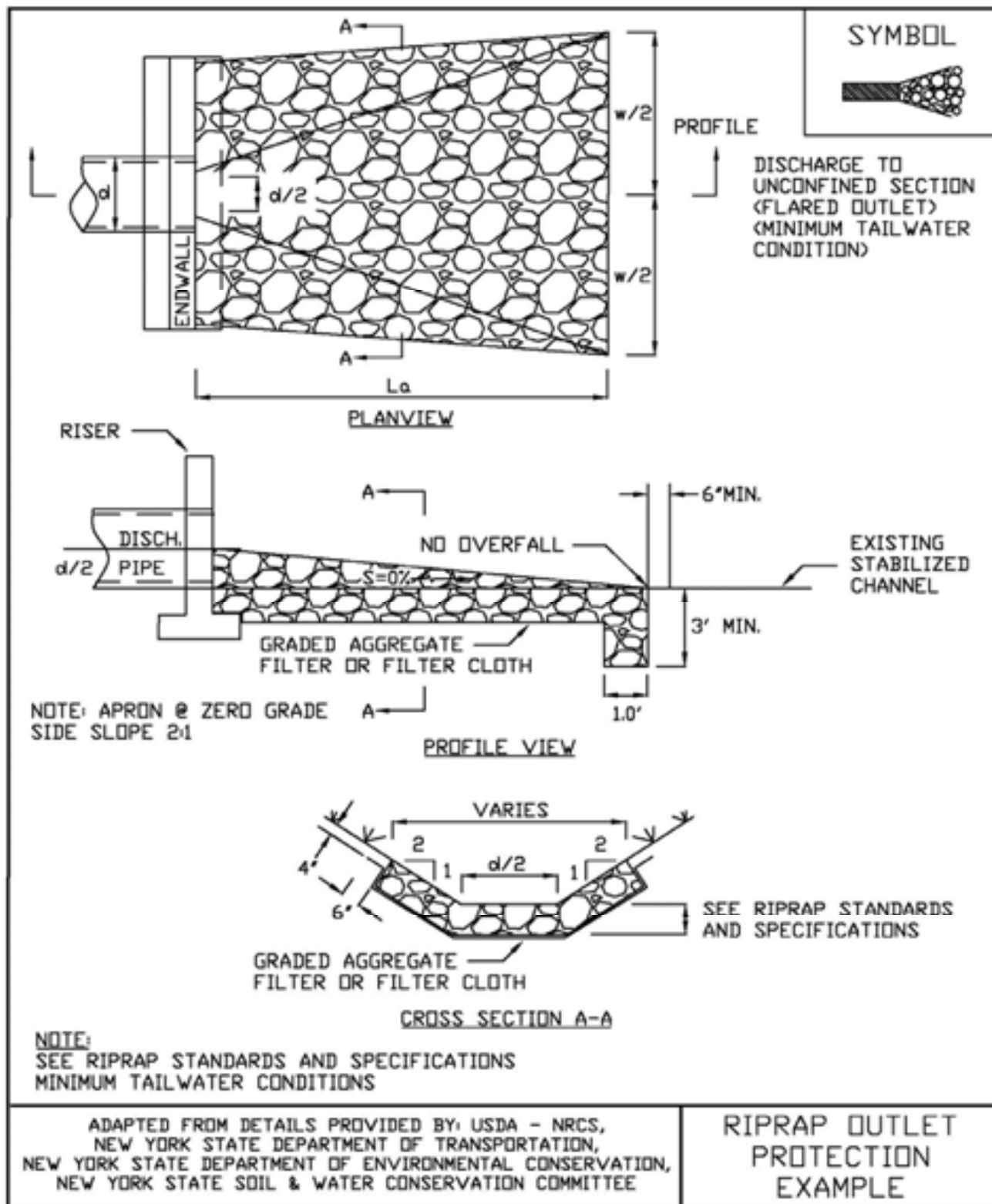

**Figure 3.19
Riprap Outlet Protection Detail (2)**

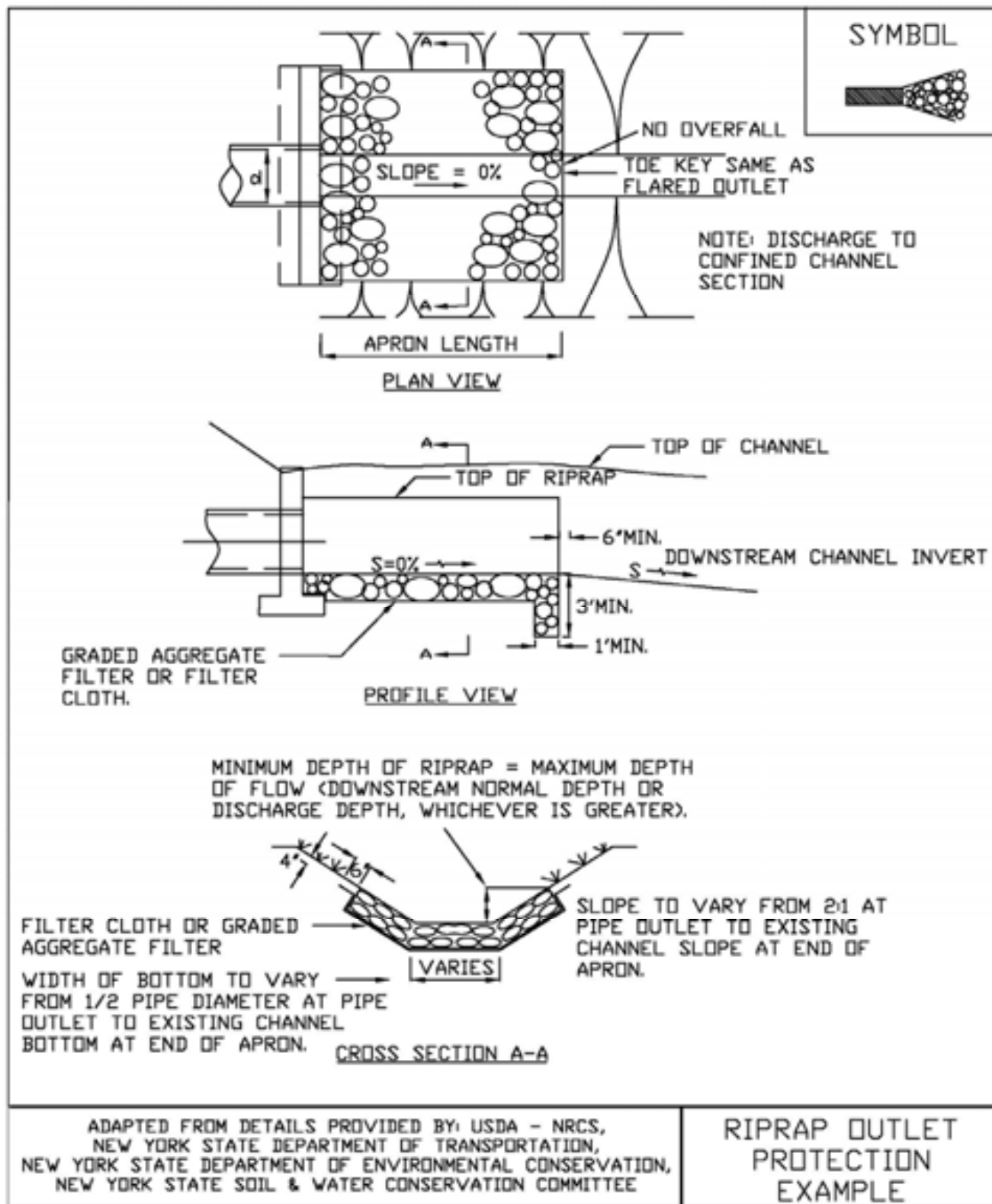

**Figure 3.20
Riprap Outlet Protection Detail (3)**

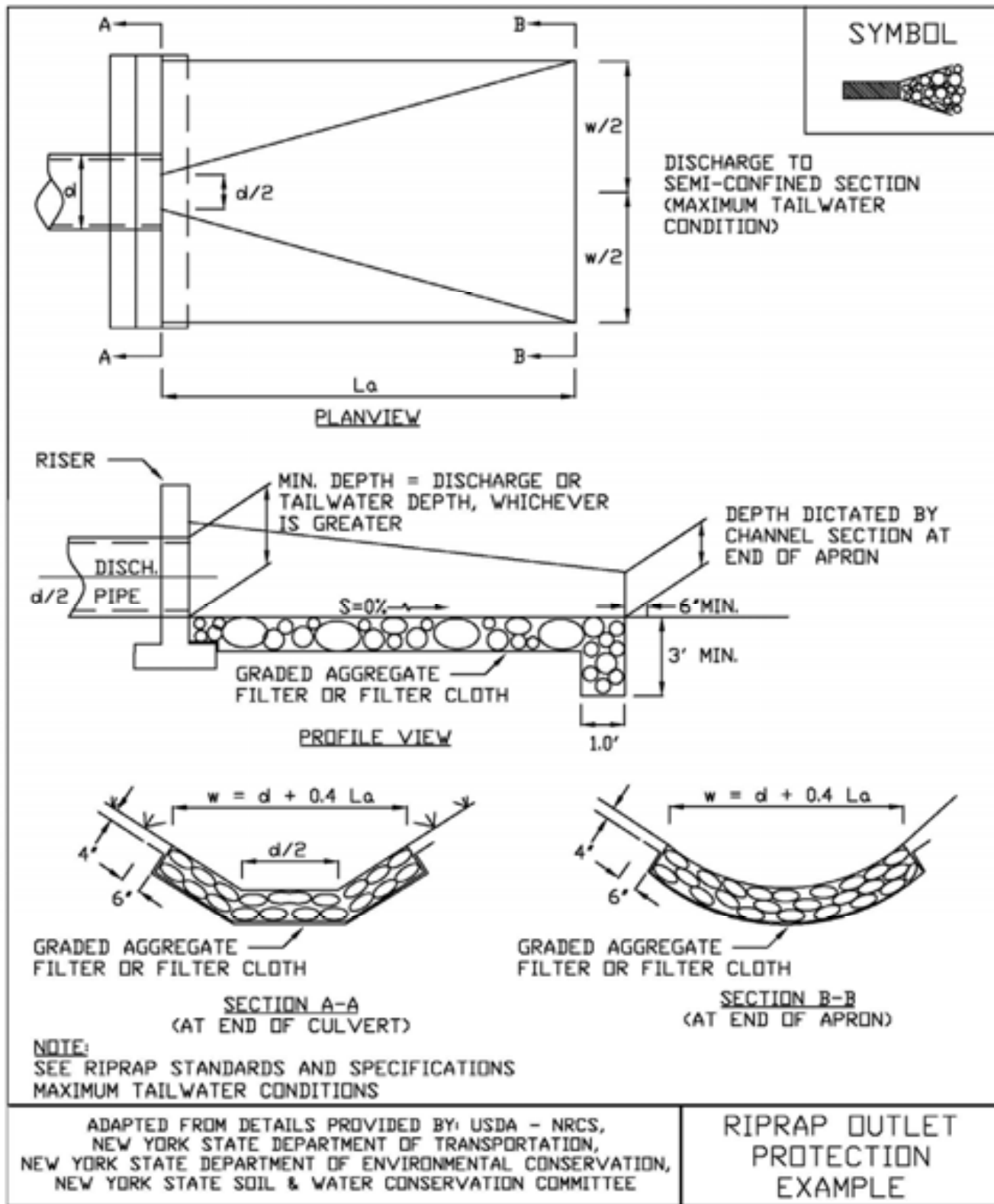

STANDARD AND SPECIFICATIONS FOR SITE POLLUTION PREVENTION



Definition & Scope

A collection of management practices intended to control non-sediment pollutants associated with construction activities to prevent the generation of pollutants due to improper handling, storage, and spills and prevent the movement of toxic substances from the site into surface waters.

Conditions Where Practice Applies

On all construction sites where the earth disturbance exceeds 5,000 square feet, and involves the use of fertilizers, pesticides, petroleum based chemicals, fuels and lubricants, as well as sealers, paints, cleared woody vegetation, garbage, and sanitary wastes.

Design Criteria

The variety of pollutants on a particular site and the severity of their impacts depend on factors such as the nature of the construction activity, the physical characteristics of the construction site, and the proximity of water bodies and conveyances to the pollutant source.

1. All state and federal regulations shall be followed for the storage, handling, application, usage, and disposal of pesticides, fertilizers, and petroleum products.
2. Vehicle and construction equipment staging and maintenance areas will be located away from all drainage ways with their parking areas graded so the runoff from these areas is collected, contained and treated prior to discharge from the site.
3. Provide sanitary facilities for on-site personnel.
4. Store, cover, and isolate construction materials including topsoil, and chemicals, to prevent runoff of

pollutants and contamination of groundwater and surface waters.

5. Develop and implement a spill prevention and control plan. The plan should include NYSDEC's spill reporting and initial notification requirements.
6. Provide adequate disposal for solid waste including woody debris, stumps, and other construction waste and include these methods and directions in the construction details on the site construction drawings. Fill, woody debris, stumps and construction waste shall not be placed in regulated wetlands, streams or other surface waters.
7. Distribute or post informational material regarding proper handling, spill response, spill kit location, and emergency actions to be taken, to all construction personnel.
8. Refueling equipment shall be located at least 100 feet from all wetlands, streams and other surface waters.



STANDARD AND SPECIFICATIONS FOR WINTER STABILIZATION



Definition & Scope

A temporary site specific, enhanced erosion and sediment control plan to manage runoff and sediment at the site during construction activities in the winter months to protect off-site water resources.

Conditions Where Practice Applies

This standard applies to all construction activities involved with ongoing land disturbance and exposure between November 15th to the following April 1st.

Design Criteria

1. Prepare a snow management plan with adequate storage for snow and control of melt water, requiring cleared snow to be stored in a manner not affecting ongoing construction activities.
2. Enlarge and stabilize access points to provide for snow management and stockpiling. Snow management activities must not destroy or degrade installed erosion and sediment control practices.
3. A minimum 25 foot buffer shall be maintained from all perimeter controls such as silt fence. Mark silt fence with tall stakes that are visible above the snow pack.
4. Edges of disturbed areas that drain to a waterbody within 100 feet will have 2 rows of silt fence, 5 feet apart, installed on the contour.
5. Drainage structures must be kept open and free of snow and ice dams. All debris, ice dams, or debris from plowing operations, that restrict the flow of runoff and meltwater, shall be removed.
6. Sediment barriers must be installed at all appropriate

perimeter and sensitive locations. Silt fence and other practices requiring earth disturbance must be installed before the ground freezes.

7. Soil stockpiles must be protected by the use of established vegetation, anchored straw mulch, rolled stabilization matting, or other durable covering. A barrier must be installed at least 15 feet from the toe of the stockpile to prevent soil migration and to capture loose soil.
8. In areas where soil disturbance activity has temporarily or permanently ceased, the application of soil stabilization measures should be initiated by the end of the next business day and completed within three (3) days. Rolled erosion control blankets must be used on all slopes 3 horizontal to 1 vertical or steeper.
9. If straw mulch alone is used for temporary stabilization, it shall be applied at double the standard rate of 2 tons per acre, making the application rate 4 tons per acre. Other manufactured mulches should be applied at double the manufacturer's recommended rate.
10. To ensure adequate stabilization of disturbed soil in advance of a melt event, areas of disturbed soil should be stabilized at the end of each work day unless:
 - a. work will resume within 24 hours in the same area and no precipitation is forecast or;
 - b. the work is in disturbed areas that collect and retain runoff, such as open utility trenches, foundation excavations, or water management areas.
11. Use stone paths to stabilize access perimeters of buildings under construction and areas where construction vehicle traffic is anticipated. Stone paths should be a minimum 10 feet in width but wider as necessary to accommodate equipment.

Maintenance

The site shall be inspected frequently to ensure that the erosion and sediment control plan is performing its winter stabilization function. If the site will not have earth disturbing activities ongoing during the "winter season", all bare exposed soil must be stabilized by established vegetation, straw or other acceptable mulch, matting, rock, or other approved material such as rolled erosion control products. Seeding of areas with mulch cover is preferred but seeding alone is not acceptable for proper stabilization.

Compliance inspections must be performed and reports filed properly in accordance with the SWPPP for all sites under a winter shutdown.

Appendix H

Inspection Forms, Checklists and Maintenance Guidelines

I. PRE-CONSTRUCTION MEETING DOCUMENTS

Project Name _____
Permit No. _____ Date of Authorization _____
Name of Operator _____
Prime Contractor _____

a. Preamble to Site Assessment and Inspections -The Following Information To Be Read By All Person's Involved in The Construction of Stormwater Related Activities:

The Operator agrees to have a qualified professional¹ conduct an assessment of the site prior to the commencement of construction² and certify in this inspection report that the appropriate erosion and sediment controls described in the SWPPP have been adequately installed or implemented to ensure overall preparedness of the site for the commencement of construction.

Prior to the commencement of construction, the Operator shall certify in this site logbook that the SWPPP has been prepared in accordance with the State's standards and meets all Federal, State and local erosion and sediment control requirements.

When construction starts, site inspections shall be conducted by the qualified professional at least every 7 calendar days and within 24 hours of the end of a storm event of 0.5 inches or greater (Construction Duration Inspections). The Operator shall maintain a record of all inspection reports in this site logbook. The site logbook shall be maintained on site and be made available to the permitting authorities upon request. The Operator shall post at the site, in a publicly accessible location, a summary of the site inspection activities on a monthly basis (Monthly Summary Report).

The operator shall also prepare a written summary of compliance with this general permit at a minimum frequency of every three months (Operator's Compliance Response Form), while coverage exists. The summary should address the status of achieving each component of the SWPPP.

Prior to filing the Notice of Termination or the end of permit term, the Operator shall have a qualified professional perform a final site inspection. The qualified professional shall certify that the site has undergone final stabilization³ using either vegetative or structural stabilization methods and that all temporary erosion and sediment controls (such as silt fencing) not needed for long-term erosion control have been removed. In addition, the Operator must identify and certify that all permanent structures described in the SWPPP have been constructed and provide the owner(s) with an operation and maintenance plan that ensures the structure(s) continuously functions as designed.

1 "Qualified Professional means a person knowledgeable in the principles and practice of erosion and sediment controls, such as a Certified Professional in Erosion and Sediment Control (CPESC), soil scientist, licensed engineer or someone working under the direction and supervision of a licensed engineer (person must have experience in the principles and practices of erosion and sediment control).

2 "Commencement of construction" means the initial removal of vegetation and disturbance of soils associated with clearing, grading or excavating activities or other construction activities.

3 "Final stabilization" means that all soil-disturbing activities at the site have been completed and a uniform, perennial vegetative cover with a density of eighty (80) percent has been established or equivalent stabilization measures (such as the use of mulches or geotextiles) have been employed on all unpaved areas and areas not covered by permanent structures.

b. Operators Certification

"I certify under penalty of law that this document and all attachments were prepared under my direction or supervision in accordance with a system designed to assure that qualified personnel properly gathered and evaluated the information submitted. Based on my inquiry of the person or persons who manage the system, or those persons directly responsible for gathering the information, the information submitted is, to the best of my knowledge and belief, true, accurate, and complete. Further, I hereby certify that the SWPPP meets all Federal, State, and local erosion and sediment control requirements. I am aware that false statements made herein are punishable as a class A misdemeanor pursuant to Section 210.45 of the Penal Law. "

Name (please print): _____

Title _____ Date: _____

Address: _____

Phone: _____ Email: _____

Signature: _____

c. Qualified Professional's Credentials & Certification

" I hereby certify that I meet the criteria set forth in the General Permit to conduct site inspections for this project and that the appropriate erosion and sediment controls described in the SWPPP and as described in the following Pre-construction Site Assessment Checklist have been adequately installed or implemented, ensuring the overall preparedness of this site for the commencement of construction."

Name (please print): _____

Title _____ Date: _____

Address: _____

Phone: _____ Email: _____

Signature: _____

d. Pre-construction Site Assessment Checklist (NOTE: Provide comments below as necessary)

1. Notice of Intent, SWPPP, and Contractors Certification:

Yes No NA

Has a Notice of Intent been filed with the NYS Department of Conservation?

Is the SWPPP on-site? Where? _____

Is the Plan current? What is the latest revision date? _____

Is a copy of the NOI (with brief description) onsite? Where? _____

Have all contractors involved with stormwater related activities signed a contractor's certification?

Pre-construction Site Assessment Checklist (continued)

2. Resource Protection

Yes No NA

- Are construction limits clearly flagged or fenced?
- Important trees and associated rooting zones, on-site septic system absorption fields, existing vegetated areas suitable for filter strips, especially in perimeter areas, have been flagged for protection.
- Creek crossings installed prior to land-disturbing activity, including clearing and blasting.

3. Surface Water Protection

Yes No NA

- Clean stormwater runoff has been diverted from areas to be disturbed.
- Bodies of water located either on site or in the vicinity of the site have been identified and protected.
- Appropriate practices to protect on-site or downstream surface water are installed.
- Are clearing and grading operations divided into areas <5 acres?

4. Stabilized Construction Entrance

Yes No NA

- A temporary construction entrance to capture mud and debris from construction vehicles before they enter the public highway has been installed.
- Other access areas (entrances, construction routes, equipment parking areas) are stabilized immediately as work takes place with gravel or other cover.
- Sediment tracked onto public streets is removed or cleaned on a regular basis.

5. Perimeter Sediment Controls

Yes No NA

- Silt fence material and installation comply with the standard drawing and specifications.
- Silt fences are installed at appropriate spacing intervals
- Sediment/detention basin was installed as first land disturbing activity.
- Sediment traps and barriers are installed.

6. Pollution Prevention for Waste and Hazardous Materials

Yes No NA

- The Operator or designated representative has been assigned to implement the spill prevention avoidance and response plan.
- The plan is contained in the SWPPP on page _____
- Appropriate materials to control spills are onsite. Where? _____

II. CONSTRUCTION DURATION INSPECTIONS

a. Directions:

Inspection Forms will be filled out during the entire construction phase of the project.

Required Elements:

(1) On a site map, indicate the extent of all disturbed site areas and drainage pathways. Indicate site areas that are expected to undergo initial disturbance or significant site work within the next 14-day period;

(2) Indicate on a site map all areas of the site that have undergone temporary or permanent stabilization;

(3) Indicate all disturbed site areas that have not undergone active site work during the previous 14-day period;

Inspect all sediment control practices and record the approximate degree of sediment accumulation as a percentage of sediment storage volume (for example, 10 percent, 20 percent, 50 percent);

(5) Inspect all erosion and sediment control practices and record all maintenance requirements such as verifying the integrity of barrier or diversion systems (earthen berms or silt fencing) and containment systems (sediment basins and sediment traps). Identify any evidence of rill or gully erosion occurring on slopes and any loss of stabilizing vegetation or seeding/mulching. Document any excessive deposition of sediment or ponding water along barrier or diversion systems. Record the depth of sediment within containment structures, any erosion near outlet and overflow structures, and verify the ability of rock filters around perforated riser pipes to pass water; and

(6) Immediately report to the Operator any deficiencies that are identified with the implementation of the SWPPP.

**STORMWATER POLLUTION PREVENTION
CONSTRUCTION DURATION INSPECTIONS**

Project:		Date:	
Job No.:		Time of inspection:	
Contractor:		Weather conditions:	
Inspector (Print name):		Temperature:	
Permit ID No.		Wind:	
		Soil Conditions:	

SUGGESTED E&SC REMEDIAL WORK BASED ON CURRENT INSPECTION:

MOIFICATIONS TO THE SWPP BASED ON CURRENT INSPECTION:

Modification and reason:

Refer to attached site plan sketch for summary of observed site conditions (page 2).
Refer to attached inspection checklist (pages 3 to 6) for items inspected.

**STORMWATER POLLUTION PREVENTION
CONSTRUCTION DURATION INSPECTIONS**

Project:		Date:	
Job No.:		Client:	

SITE SKETCH

Project:		Date:	
Job No.:		Client:	

INSPECTION CHECKLIST

Maintaining Water quality

- | Yes | No | N/A | |
|--------------------------|--------------------------|--------------------------|--|
| <input type="checkbox"/> | <input type="checkbox"/> | <input type="checkbox"/> | Is there an increase in turbidity causing a substantial visible? Contrast to natural conditions? |
| <input type="checkbox"/> | <input type="checkbox"/> | <input type="checkbox"/> | Is there residue from oil and floating substances, visible oil film, oil globules or grease |
| <input type="checkbox"/> | <input type="checkbox"/> | <input type="checkbox"/> | Have receiving lake/bay, stream, and/or wetland been impacted by silt from project? |

Housekeeping

1. General Site conditions

- | Yes | No | N/A | |
|--------------------------|--------------------------|--------------------------|--|
| <input type="checkbox"/> | <input type="checkbox"/> | <input type="checkbox"/> | Is construction site litter and debris appropriately managed? |
| <input type="checkbox"/> | <input type="checkbox"/> | <input type="checkbox"/> | Are facilities and equipment necessary for implementation of erosion and sediment control in working order and/or properly maintained. |
| <input type="checkbox"/> | <input type="checkbox"/> | <input type="checkbox"/> | Is all disturbance within the limits of the approved plans? (i.e. no construction impacts to the adjacent property)? |
| <input type="checkbox"/> | <input type="checkbox"/> | <input type="checkbox"/> | Is dust adequately controlled? |

2. Temporary Stream crossing

- | Yes | No | N/A | |
|--------------------------|--------------------------|--------------------------|--|
| <input type="checkbox"/> | <input type="checkbox"/> | <input type="checkbox"/> | Maximum diameter pipes necessary to span creek without dredging are installed. |
| <input type="checkbox"/> | <input type="checkbox"/> | <input type="checkbox"/> | Installed non-woven geotextile fabric beneath approaches. |
| <input type="checkbox"/> | <input type="checkbox"/> | <input type="checkbox"/> | Is fill composed of aggregate (no earth or soil)? |
| <input type="checkbox"/> | <input type="checkbox"/> | <input type="checkbox"/> | Rock on approaches is clean enough to remove mud from vehicles and prevent sediment from entering stream during high flow. |

**STORMWATER POLLUTION PREVENTION
CONSTRUCTION DURATION INSPECTIONS**

Project:		Date:	
Job No.:		Client:	

Runoff Control practices

1. Excavation Dewatering

- | Yes | No | N/A | |
|--------------------------|--------------------------|--------------------------|---|
| <input type="checkbox"/> | <input type="checkbox"/> | <input type="checkbox"/> | Upstream and downstream berms (sandbags, inflatable dams, etc.) are installed per plan. |
| <input type="checkbox"/> | <input type="checkbox"/> | <input type="checkbox"/> | Clean water from upstream pool is being pumped to the downstream pool. |
| <input type="checkbox"/> | <input type="checkbox"/> | <input type="checkbox"/> | Sediment laden water from work area is being discharged to a silt-trapping device. |
| <input type="checkbox"/> | <input type="checkbox"/> | <input type="checkbox"/> | Constructed upstream berm with one-foot minimum freeboard. |

2. Level Spreader

- | Yes | No | N/A | |
|--------------------------|--------------------------|--------------------------|--|
| <input type="checkbox"/> | <input type="checkbox"/> | <input type="checkbox"/> | Installed per plan. |
| <input type="checkbox"/> | <input type="checkbox"/> | <input type="checkbox"/> | Constructed on undisturbed soil, not on fill, receiving only clear, non-sediment laden flow. |
| <input type="checkbox"/> | <input type="checkbox"/> | <input type="checkbox"/> | Flow sheets out of level spreader without erosion on downstream edge. |

3. Interceptor Dikes and Swales

- | Yes | No | N/A | |
|--------------------------|--------------------------|--------------------------|--|
| <input type="checkbox"/> | <input type="checkbox"/> | <input type="checkbox"/> | Installed per plan with minimum side slopes @ 2H:1V or flatter. |
| <input type="checkbox"/> | <input type="checkbox"/> | <input type="checkbox"/> | Stabilized by geotextile fabric, seed, or mulch with no erosion occurring. |
| <input type="checkbox"/> | <input type="checkbox"/> | <input type="checkbox"/> | Sediment-laden runoff directed to sediment trapping structure. |

4. Stone check Dam

- | Yes | No | N/A | |
|--------------------------|--------------------------|--------------------------|--|
| <input type="checkbox"/> | <input type="checkbox"/> | <input type="checkbox"/> | Is channel stable? (flow is not eroding soil underneath or around the structure). |
| <input type="checkbox"/> | <input type="checkbox"/> | <input type="checkbox"/> | Check is in good condition (rocks in place and no permanent pools behind the structure). |
| <input type="checkbox"/> | <input type="checkbox"/> | <input type="checkbox"/> | Has accumulated sediment been removed? |

**STORMWATER POLLUTION PREVENTION
CONSTRUCTION DURATION INSPECTIONS**

Project:		Date:	
Job No.:		Client:	

5. Rock Outlet protection

- | Yes | No | N/A | |
|--------------------------|--------------------------|--------------------------|--|
| <input type="checkbox"/> | <input type="checkbox"/> | <input type="checkbox"/> | Installed per plan |
| <input type="checkbox"/> | <input type="checkbox"/> | <input type="checkbox"/> | Installed concurrently with pipe installation. |

Soil stabilization

1. Topsoil and Spoil Stockpiles.

- | Yes | No | N/A | |
|--------------------------|--------------------------|--------------------------|---|
| <input type="checkbox"/> | <input type="checkbox"/> | <input type="checkbox"/> | Stockpiles are stabilized with vegetation and/or mulch. |
| <input type="checkbox"/> | <input type="checkbox"/> | <input type="checkbox"/> | Sediment control is installed at the toe of the slope. |

2. Revegetation

- | Yes | No | N/A | |
|--------------------------|--------------------------|--------------------------|---|
| <input type="checkbox"/> | <input type="checkbox"/> | <input type="checkbox"/> | Temporary seedings and mulch have been applied to idle areas. |
| <input type="checkbox"/> | <input type="checkbox"/> | <input type="checkbox"/> | Four (4) inches minimum of topsoil has been applied under permanent seedings. |

Sediment Control

1. Stabilize Construction Entrance.

- | Yes | No | N/A | |
|--------------------------|--------------------------|--------------------------|---|
| <input type="checkbox"/> | <input type="checkbox"/> | <input type="checkbox"/> | Stone is clean enough to effectively remove mud from vehicles. |
| <input type="checkbox"/> | <input type="checkbox"/> | <input type="checkbox"/> | Installed per standards and specifications? |
| <input type="checkbox"/> | <input type="checkbox"/> | <input type="checkbox"/> | Does all traffic use the stabilized entrance to enter and leave site? |
| <input type="checkbox"/> | <input type="checkbox"/> | <input type="checkbox"/> | Is adequate drainage provided to prevent ponding at entrance? |

2. Silt Fence.

- | Yes | No | N/A | |
|--------------------------|--------------------------|--------------------------|---|
| <input type="checkbox"/> | <input type="checkbox"/> | <input type="checkbox"/> | Installed on Contour, 10 feet from toe of slope (not across conveyance channels). |
| <input type="checkbox"/> | <input type="checkbox"/> | <input type="checkbox"/> | Joints constructed by wrapping the two ends together for continuous support. |
| <input type="checkbox"/> | <input type="checkbox"/> | <input type="checkbox"/> | Fabric buried six (6) inches minimum. |
| <input type="checkbox"/> | <input type="checkbox"/> | <input type="checkbox"/> | Posts are stable, fabric is tight and without rips or frayed areas. Sediment accumulation is <u> </u> % of capacity. |

**STORMWATER POLLUTION PREVENTION
CONSTRUCTION DURATION INSPECTIONS**

Project:		Date:	
Job No.:		Client:	

3. Storm Drain Inlet Protection (Use for Stone & Block; Filter Fabric; Curb; or Excavated Practices).

Yes	No	N/A	
<input type="checkbox"/>	<input type="checkbox"/>	<input type="checkbox"/>	Installed concrete blocks lengthwise so open ends face outward, not upward.
<input type="checkbox"/>	<input type="checkbox"/>	<input type="checkbox"/>	Place wire screen between No.3 crushed stone and concrete blocks.
<input type="checkbox"/>	<input type="checkbox"/>	<input type="checkbox"/>	Drainage area is one (1) acre or less.
<input type="checkbox"/>	<input type="checkbox"/>	<input type="checkbox"/>	Excavated area is 900 cubic feet.
<input type="checkbox"/>	<input type="checkbox"/>	<input type="checkbox"/>	Excavated side slopes should be 2:1.
<input type="checkbox"/>	<input type="checkbox"/>	<input type="checkbox"/>	2' x 4' frame is constructed and structurally sound.
<input type="checkbox"/>	<input type="checkbox"/>	<input type="checkbox"/>	Posts 3-foot maximum spacing between posts.
<input type="checkbox"/>	<input type="checkbox"/>	<input type="checkbox"/>	Fabric is embedded 1 to 1.5 feet below ground and secured to frame/post with staples at max 8-inch spacing.
<input type="checkbox"/>	<input type="checkbox"/>	<input type="checkbox"/>	Posts are stable, fabric is tight and without rips or frayed areas. Sediment accumulation ___%of design capacity.

4. Temporary Sediment Trap

Yes	No	N/A	
<input type="checkbox"/>	<input type="checkbox"/>	<input type="checkbox"/>	Outlet structure is constructed per the approved plan or drawing.
<input type="checkbox"/>	<input type="checkbox"/>	<input type="checkbox"/>	Geotextile fabric has been placed beneath rock fill. Sediment Accumulation is _____% of design capacity.

5. Temporary Sediment Basin

Yes	No	N/A	
<input type="checkbox"/>	<input type="checkbox"/>	<input type="checkbox"/>	Basin and outlet structure constructed per the approved plan.
<input type="checkbox"/>	<input type="checkbox"/>	<input type="checkbox"/>	Basin side slopes are stabilized with seed/mulch.
<input type="checkbox"/>	<input type="checkbox"/>	<input type="checkbox"/>	Drainage structure flushed and basin restored upon removal of Sediment basin facility. Sediment accumulation ___% of design capacity.

**STORMWATER POLLUTION PREVENTION
CONSTRUCTION DURATION INSPECTIONS**

Project:		Date:	
Job No.:		Client:	

Additional Field Observations/Comments:

Qualified Professional Verification:

“I acknowledge that, to the best of my knowledge, all information provided within this inspection report is accurate and complete”.

Qualified Professional (print name): _____

(signature): _____

**STORMWATER POLLUTION PREVENTION
CONSTRUCTION DURATION INSPECTIONS**

PHOTOGRAPHS OF SITE E&S DEFICIENCIES:

H.2 Bioretention

Planting Soil Bed Characteristics

The characteristics of the soil for the bioretention facility are perhaps as important as the facility location, size, and treatment volume. The soil must be permeable enough to allow runoff to filter through the media, while having characteristics suitable to promote and sustain a robust vegetative cover crop. In addition, much of the nutrient pollutant uptake (nitrogen and phosphorus) is accomplished through adsorption and microbial activity within the soil profile. Therefore, the soils must balance soil chemistry and physical properties to support biotic communities above and below ground.

The planting soil should be a sandy loam, loamy sand, loam (USDA), or a loam/sand mix (should contain a minimum 35 to 60% sand, by volume). The clay content for these soils should be less than 25% by volume. Soils should fall within the SM, or ML classifications of the Unified Soil Classification System (USCS). A permeability of at least 1.0 feet per day (0.5"/hr) is required (a conservative value of 0.5 feet per day is used for design). The soil should be free of stones, stumps, roots, or other woody material over 1" in diameter. Brush or seeds from noxious weeds. Placement of the planting soil should be in lifts of 12 to 18", loosely compacted (tamped lightly with a dozer or backhoe bucket). The specific characteristics are presented in Table H.2.

Table H.2 Planting Soil Characteristics

Parameter	Value
PH range	5.2 to 7.00
Organic matter	1.5 to 4.0%
Magnesium	35 lbs. per acre, minimum
Phosphorus (P ₂ O ₅)	75 lbs. per acre, minimum
Potassium (K ₂ O)	85 lbs. per acre, minimum
Soluble salts	≤ 500 ppm
Clay	10 to 25%
Silt	30 to 55%
Sand	35 to 60%

Mulch Layer

The mulch layer plays an important role in the performance of the bioretention system. The mulch layer helps maintain soil moisture and avoid surface sealing which reduces permeability. Mulch helps prevent erosion, and provides a micro-environment suitable for soil biota at the mulch/soil interface. It also serves as a pretreatment layer, trapping the finer sediments which remain suspended after the primary pretreatment.

The mulch layer should be standard landscape style, single or double, shredded hardwood mulch or chips. The mulch layer should be well aged (stockpiled or stored for at least 12 months), uniform in color, and free of other materials, such as weed seeds, soil, roots, etc. The mulch should be applied to a maximum depth of three inches. Grass clippings should not be used as a mulch material.

Planting Plan Guidance

Plant material selection should be based on the goal of simulating a terrestrial forested community of native species. Bioretention simulates an ecosystem consisting of an upland-oriented community dominated by trees, but having a distinct community, or sub-canopy, of understory trees, shrubs and herbaceous materials. The intent is to establish a diverse, dense plant cover to treat stormwater runoff and withstand urban stresses from insect and disease infestations, drought, temperature, wind, and exposure.

The proper selection and installation of plant materials is key to a successful system. There are essentially three zones within a bioretention facility (Figure H.1). The lowest elevation supports plant species adapted to standing and fluctuating water levels. The middle elevation supports a slightly drier group of plants, but still tolerates fluctuating water levels. The outer edge is the highest elevation and generally supports plants adapted to dryer conditions. When using Table A.5 to identify species, use the following guideline:

Lowest Zone: Zones 2-3

Middle Zone: Zones 3-4

Outer Zone: Zones 5-6

The layout of plant material should be flexible, but should follow the general principals described in Table H.3. The objective is to have a system which resembles a random and natural plant layout, while maintaining optimal conditions for plant establishment and growth.

Figure H.1 Planting Zones for Bioretention Facilities

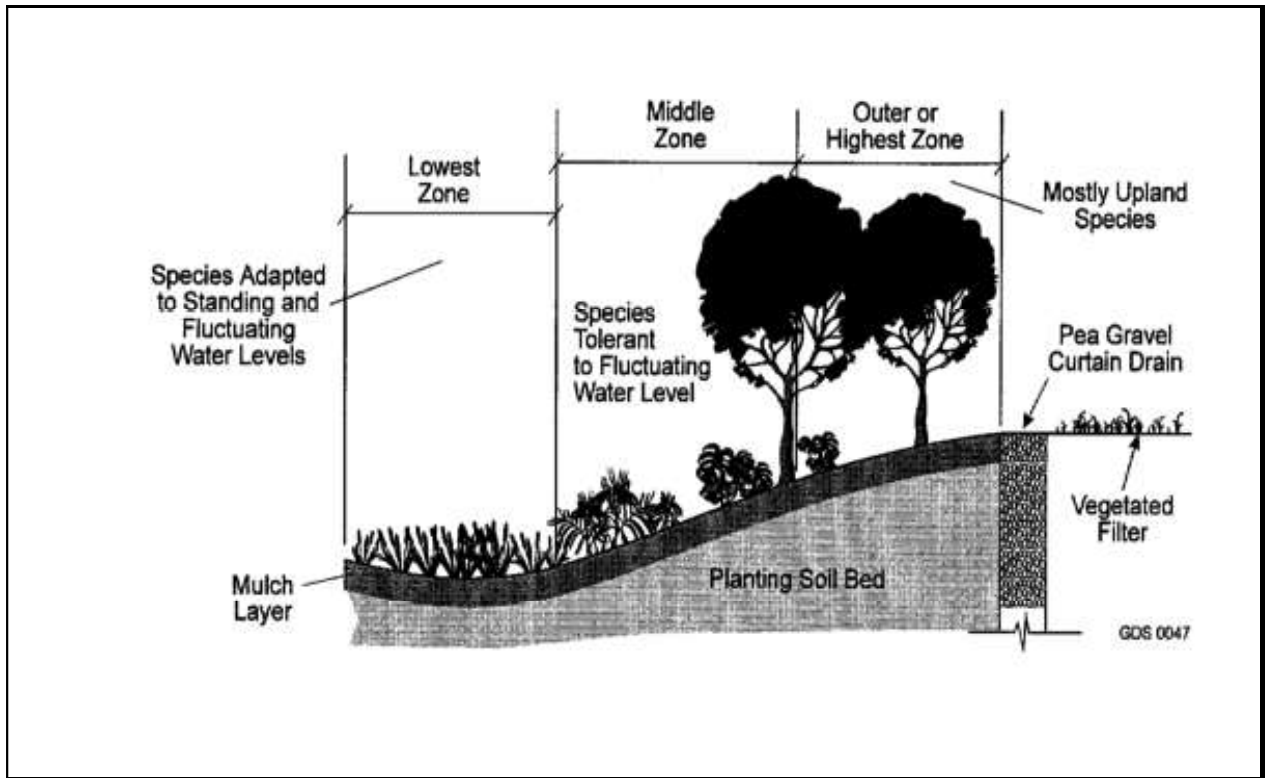

Table H.3 Planting Plan Design Considerations
Native plant species should be specified over exotic or foreign species.
Appropriate vegetation should be selected based on the zone of hydric tolerance (see Figure H.1).
Species layout should generally be random and natural.
A canopy should be established with an understory of shrubs and herbaceous materials.
Woody vegetation should not be specified in the vicinity of inflow locations.
Trees should be planted primarily along the perimeter of the bioretention area.
Urban stressors (e.g., wind, sun, exposure, insect and disease infestation, drought) should be considered when laying out the planting plan.
Noxious weeds should not be specified.
Aesthetics and visual characteristics should be a prime consideration.
Traffic and safety issues must be considered.
Existing and proposed utilities must be identified and considered.

Plant Material Guidance

Plant materials should conform to the American Standard Nursery Stock, published by the American Association of Nurserymen, and should be selected from certified, reputable nurseries. Planting specifications should be prepared by the designer and should include a sequence of construction, a description of the contractor's responsibilities, a planting schedule and installation specifications, initial maintenance, and a warranty period and expectations of plant survival. Table H.4 presents some typical issues for planting specifications.

Table H.4 Planting Specification Issues for Bioretention Areas	
Specification Element	Elements
Sequence of Construction	Describe site preparation activities, soil amendments, etc.; address erosion and sediment control procedures; specify step-by-step procedure for plant installation through site clean-up.
Contractor's Responsibilities	Specify the contractor's responsibilities, such as watering, care of plant material during transport, timeliness of installation, repairs due to vandalism, etc.
Planting Schedule and Specifications	Specify the materials to be installed, the type of materials (e.g., B&B, bare root, containerized); time of year of installations, sequence of installation of types of plants; fertilization, stabilization seeding, if required; watering and general care.
Maintenance	Specify inspection periods; mulching frequency (annual mulching is most common); removal and replacement of dead and diseased vegetation; treatment of diseased trees; watering schedule after initial installation (once per day for 14 days is common); repair and replacement of staking and wires.
Warranty	Specify the warranty period, the required survival rate, and expected condition of plant species at the end of the warranty period.

Table H.5 Native Plant Guide for Stormwater Management Areas (NY)						
Plant Name	Zone	Form	Available	Inundation Tolerance	Wildlife Value	Notes
Trees and Shrubs						
American Elm (<i>Ulmus americana</i>)	4,5,6	Dec. Tree	yes	Irregular-seasonal saturation	High. Food (seeds, browsing), cover, nesting for birds & mammals	Susceptible to disease (short-lived). Sun to full shade, tolerates drought and wind/ice damage.
Arrowwood Viburnum (<i>Viburnum dentatum</i>)	3,4	Dec. Shrub	yes	yes	High. Songbirds and mammals	Grows best in sun to partial shade
Bald Cypress (<i>Taxodium distichum</i>)	3,4	Dec. Tree	yes	yes	Little food value, but good perching site for waterfowl	Forested Coastal Plain. North of normal range. Tolerates drought.
Bayberry (<i>Myrica pensylvanica</i>)	4,5,6	Dec. Shrub	yes	yes	High. Nesting, food, cover. Berries last into winter	Coastal Plain only. Roots fix N ₂ . Tolerates slightly acidic soils.
Black Ash (<i>Fraxinus nigra</i>)	3,4,5	Dec. Tree	yes	Irregular-seasonal saturation	High. Food (seeds, sap), cover, nesting for birds & mammals. Fruit persists in winter	Rapid growth. Requires full sun. Susceptible to wind/ice damage & disease. Tolerates drought and infrequent flooding by salt water.
Black Cherry (<i>Prunus serotina</i>)	5,6	Dec. Tree	yes	no	High. Food	Moist soils or wet bottomland areas
Blackgum or Sourgum (<i>Nyssa sylvatica</i>)	4,5,6	Dec. Tree	yes	yes	High. Songbirds, egrets, herons, raccoons, owls	Can be difficult to transplant. Prefers sun to partial shade
Black Willow (<i>Salix nigra</i>)	3,4,5	Dec. Tree	yes	yes	High. Browsing and cavity nesters.	Rapid growth, stabilizes stream-banks. Full sun
Buttonbush (<i>Cephalanthus occidentalis</i>)	2,3,4,5	Dec. Shrub	yes	yes	High. Ducks and shorebirds. Seeds, nectar and nesting.	Full sun to partial shade. Will grow in dry areas.
Common Spice Bush (<i>Lindera benzoin</i>)	3,4,5	Dec. Shrub	yes	yes	Very high. Songbirds	Shade and rich soils. Tolerates acidic soils. Good understory species

Table H.5 Native Plant Guide for Stormwater Management Areas (NY)						
Plant Name	Zone	Form	Available	Inundation Tolerance	Wildlife Value	Notes
Eastern Cottonwood (<i>Populus deltoides</i>)	4,5	Dec. Tree	yes	yes	Moderate. Cover, food.	Shallow rooted, subject to windthrow. Invasive roots. Rapid growth.
Eastern Hemlock (<i>Tsuga canadensis</i>)	5,6	Conif. Tree	yes	yes	Moderate. Mostly cover and some food	Tolerates all sun/shade conditions. Tolerates acidic soil.
Eastern Red Cedar (<i>Juniperus virginiana</i>)	4,5,6	Conif. Tree	yes	no	High. Fruit for birds. Some cover.	Full sun to partial shade. Common in wetlands, shrub bogs and edge of stream
Elderberry (<i>Sambucus canadensis</i>)	3,4,5,6	Dec. Shrub	yes	yes	Extremely high. Food and cover, birds and mammals.	Full sun to partial shade.
Green Ash, Red Ash (<i>Fraxinus pennsylvanica</i>)	4,5	Dec. Tree	yes	yes	Moderate. Songbirds.	Rapid growing streambank stabilizer. Full sun to partial shade.
Hackberry (<i>Celtis occidentalis</i>)	5,6	Dec. Tree	yes	some	High. Food and cover	Full sun to partial shade.
Larch, Tamarack (<i>Larix laricina</i>)	3,4	Conif. Tree	no	yes	Low. Nest tree and seeds.	Rapid initial growth. Full sun, acidic boggy soil.
Pin Oak (<i>Quercus palustris</i>)	3,4,5,6	Dec. Tree	yes	yes	High. Tolerates acidic soil	Gypsy moth target. Prefers well drained, sandy soils.
Red Choke Berry (<i>Pyrus arbutifolia</i>)	3,4,5	Dec. Shrub	no	yes	Moderate. Songbirds.	Bank stabilizer. Partial sun.
Red Maple (<i>Acer rubrum</i>)	3,4,5,6	Dec. Tree	yes	yes	High seeds and browse. Tolerates acidic soil.	Rapid growth.
River Birch (<i>Betula nigra</i>)	3,4,5	Dec. Tree	yes	yes	Low. Good for cavity nesters.	Bank erosion control. Full sun.
Shadowbush, Serviceberry (<i>Amelanchier</i>)	4,5,6	Dec. Shrub	yes	yes	High. Nesting, cover, food. Birds and	Prefers partial shade. Common in forested

Table H.5 Native Plant Guide for Stormwater Management Areas (NY)						
Plant Name	Zone	Form	Available	Inundation Tolerance	Wildlife Value	Notes
<i>canadensis</i>)					mammals.	wetlands and upland woods.
Silky Dogwood (<i>Cornus amomium</i>)	3,4,5	Dec. Shrub	yes	yes	High. Songbirds, mammals.	Shade and drought tolerant. Good bank stabilizer.
Slippery Elm (<i>Ulmus rubra</i>)	3,4,5	Dec. Tree	rare	yes	High. Food (seeds, buds) for birds & mammals (browse). Nesting	Rapid growth, no salinity tolerance. Tolerant to shade and drought.
Smooth Alder (<i>Alnus serrulata</i>)	3,4,5	Dec. Tree	no	yes	High. Food, cover.	Rapid growth. Stabilizes streambanks.
Speckled Alder (<i>Alnus rugosa</i>)	3,4	Dec. Shrub	yes	yes	High. Cover, browse for deer, seeds for bird.	
Swamp White Oak (<i>Quercus bicolor</i>)	3,4,5	Dec. Tree	yes	yes	High. Mast	Full sun to partial shade. Good bottomland tree.
Swamp Rose (<i>Rosa Palustris</i>)	3,4	Dec. Shrub		Irregular, seasonal, or regularly saturated	High. Food (hips) for birds including turkey, ruffed grouse and mammals. Fox cover.	Prefers full sun. Easy to establish. Low salt tolerance.
Sweetgum (<i>Liquidambar styraciflua</i>)	4,5,6	Dec. Tree	yes	yes	Moderate. Songbirds	Tolerates acid or clay soils. Sun to partial shade.
Sycamore (<i>Platanus occidentalis</i>)	4,5,6,	Dec. Tree	yes	yes	Low. Food, cavities for nesting.	Rapid growth. Common in floodplains and alluvial woodlands.
Tulip Tree (<i>Liriodendron tulipifera</i>)	5,6	Dec. Tree	yes	no	Moderate. Seeds and nest sites	Full sun to partial shade. Well drained soils. Rapid growth.
Tupelo (<i>Nyssa sylvatica vari biflora</i>)	3,4,5	Dec. Tree	yes	yes	High. Seeds and nest sites	Ornamental

Table H.5 Native Plant Guide for Stormwater Management Areas (NY)						
Plant Name	Zone	Form	Available	Inundation Tolerance	Wildlife Value	Notes
White Ash (<i>Fraxinus americana</i>)	5,6	Dec. Tree	yes	no	High. Food	All sunlight conditions. Well drained soils.
Winterberry (<i>Ilex verticillata</i>)	3,4,5	Dec. Shrub	yes	yes	High. Cover and fruit for birds. Holds berries into winter.	Full sun to partial shade. Seasonally flooded areas.
Witch Hazel (<i>Hamamelis virginiana</i>)	4,5	Dec. Shrub	yes	no	Low. Food for squirrels, deer, and ruffed grouse.	Prefers shade. Ornamental.
Herbaceous Plants						
Arrow arum (<i>Peltandra virginica</i>)	2,3	Emergent	yes	up to 1 ft.	High. Berries are eaten by wood ducks.	Full sun to partial shade.
Arrowhead, Duck Potato (<i>Sagittaria latifolia</i>)	2,3	Emergent	yes	up to 1 ft.	Moderate. Tubers and seeds eaten by ducks.	Aggressive colonizer.
Big Bluestem (<i>Andropogon gerardi</i>)	4,5	Perimeter	yes	Irregular or seasonal inundation.	High. Seeds for songbirds. Food for deer	Requires full sun.
Birdfoot deervetch (<i>Lotus Corniculatus</i>)	4,5,6	Perimeter	yes	Infrequent inundation	High. Food for birds.	Full sun. Nitrogen fixer.
Blue Flag Iris (<i>Iris versicolor</i>)	2,3	Emergent	yes	Regular or permanently, up to ½ ft or saturated	Moderate. Food muskrat and wildfowl. Cover, marshbirds	Slow growth. Full sun to partial shade. Tolerates clay. Fresh to moderately brackish water.
Blue Joint (<i>Calamagrotis canadensis</i>)	2,3,4	Emergent	yes	Regular or permanent inundation up to 0.5 ft.	Moderate. Food for game birds and moose.	Tolerates partial shade
Broomsedge (<i>Andropogon virginicus</i>)	2,3	Perimeter	yes	up to 3 in.	High. Songbirds and browsers. Winter food and cover.	Tolerant of fluctuation water levels & partial shade.
Bushy Beardgrass (<i>Andropogon glomeratus</i>)	2,3	Emergent	yes	up to 1 ft.		Requires full sun.
Cardinal flower (<i>Lobelia cardinalis</i>)	4,5,6	Perimeter	yes	Some. Tolerates saturation up to 100% of season.	High. Nectar for hummingbird, oriole, butterflies.	Tolerates partial shade

Table H.5 Native Plant Guide for Stormwater Management Areas (NY)						
Plant Name	Zone	Form	Available	Inundation Tolerance	Wildlife Value	Notes
Cattail (<i>Typha sp.</i>)	2,3	Emergent	yes	up to 1 ft.	Low. Except as cover	Aggressive. May eliminate other species. Volunteer. High pollutant treatment
Coontail (<i>Ceratophyllum demersum</i>)	1	Submergent	no	yes	Low food value. Good habitat and shelter for fish and invertebrates.	Free floating SAV. Shade tolerant. Rapid growth.
Common Three-Square (<i>Scirpus pungens</i>)	2	Emergent	yes	up to 6 in.	High. Seeds, cover. Waterfowl and fish.	High metal removal.
Duckweed (<i>Lemna sp.</i>)	1,2	Submergent/ Emergent	yes	yes	High. Food for waterfowl and fish.	High metal removal.
Fowl mannagrass (<i>Glyceria striata</i>)	4,5	Perimeter	yes	Irregular or seasonal inundation	High. Food for waterfowl, muskrat, and deer.	Partial to full shade.
Hardstem Bulrush (<i>Scirpus acutus</i>)	2	Emergent	yes	up to 3 ft.	High. Cover, food (achenes, rhizomes) ducks, geese, muskrat, fish. Nesting for bluegill and bass.	Quick to establish, fresh to brackish. Good for sediment stabilization and erosion control.
Giant Burreed (<i>Sparganium eurycarpum</i>)	2,3	Emergent	rare	Regular to permanently inundated. up to 1 ft.	High. Food (seeds, plant) waterfowl, beaver & other mammals. Cover for marshbirds, waterfowl.	Rapid spreading. Tolerates partial sun. Good for shoreline stabilization.. Salinity <0.5 ppt
Lizard's Tail (<i>Saururus cernuus</i>)	2	Emergent	yes	up to 1 ft.	Low, except wood ducks.	Rapid growth. Shade tolerant
Long-leaved Pond Weed (<i>Potamogeton nodosus</i>)	1,2	Rooted submerged aquatic	yes	up to 1-6 ft. depending on turbidity	High. Food (seeds, roots) waterfowl, aquatic fur-bearers, deer, moose. Habitat for fish	Rapid spread. Salinity <0.5 ppt. Flowers float on surface, Aug.-Sept.

Table H.5 Native Plant Guide for Stormwater Management Areas (NY)						
Plant Name	Zone	Form	Available	Inundation Tolerance	Wildlife Value	Notes
Marsh Hibiscus (<i>Hibiscus moscheutos</i>)	2,3	Emergent	yes	up to 3 in.	Low. Nectar.	Full sun. Can tolerate periodic dryness.
Pickernelweed (<i>Pontederia cordata</i>)	2,3	Emergent	yes	up to 1 ft.	Moderate. Ducks. Nectar for butterflies.	Full sun to partial shade.
Pond Weed, Sago (<i>Potamogeton pectinatus</i>)	1	Submergent	yes	yes	Extremely high. Waterfowl, marsh and shorebirds.	Removes heavy metals.
Redtop (<i>Agrostis alba</i>)	3,4,5	Perimeter	yes	Up to 25% of season	Moderate. Rabbits and some birds.	Quickly established but not highly competitive.
Rice Cutgrass (<i>Leersia oryzoides</i>)	2,3	Emergent	yes	up to 3 in.	High. Food and cover.	Full sun although tolerant of shade. Shoreline stabilization.
Sedges (<i>Carex spp.</i>)	2,3	Emergent	yes	up to 3 in.	High waterfowl, songbirds.	Many wetland and upland species.
Tufted Hairgrass (<i>Deschampsia caespitosa</i>)	3,4,5	Perimeter	yes	Regular to irregular inundation.	High.	Full sun. May become invasive.
Soft-stem Bulrush (<i>Scirpus validus</i>)	2,3	Emergent	yes	up to 1 ft.	Moderate. Good cover and food.	Full sun. Aggressive colonizer. High pollutant removal.
Smartweed (<i>Polygonum spp.</i>)	2,3,4	Emergent	yes	up to 1 ft.	High. Waterfowl, songbirds. Seeds and cover.	Fast colonizer. Avoid weedy aliens such as <i>P. perfoliatum</i> .
Soft Rush (<i>Juncus effusus</i>)	2,3,4	Emergent	yes	up to 3 in.	Moderate.	Tolerates wet or dry conditions.
Spatterdock (<i>Nuphar luteum</i>)	2	Emergent	yes	up to 3 ft.	Moderate for food but high for cover.	Fast colonizer. Tolerant of fluctuating water levels.
Switchgrass (<i>Panicum virgatum</i>)	2,3,4,5,6	Perimeter	yes	up to 3 in.	High. Seeds, cover for waterfowl, songbirds.	Tolerates wet/dry conditions.

Table H.5 Native Plant Guide for Stormwater Management Areas (NY)						
Plant Name	Zone	Form	Available	Inundation Tolerance	Wildlife Value	Notes
Sweet Flag (<i>Acorus calamus</i>)	2,3	Herbaceous	yes	up to 3 in.	Low.	Tolerant of dry periods. Not a rapid colonizer. Tolerates acidic conditions.
Waterweed (<i>Elodea canadensis</i>)	1	Submergent	yes	yes	Low.	Good water oxygenator. High nutrient, copper, manganese and chromium removal.
Wild Celery (<i>Valisneria americana</i>)	1	Submergent	yes	yes	High. Food for waterfowl. Habitat for fish and invertebrates.	Tolerant of murky water and high nutrient loads.
Wild Rice (<i>Zizania aquatica</i>)	2	Emergent	yes	up to 1 ft.	High. Food for birds.	Prefers full sun
Wool Grass (<i>Scirpus cyperinus</i>)	2,3	Emergent	yes	Irregularly to seasonally inundated	Moderate. Cover, Food.	Requires full sun. Can tolerate acidic soils, drought. Colonizes disturbed areas, moderate growth.

Bioretention Operation, Maintenance and Management Inspection Checklist

Project:
 Location:
 Site Status:

Date:

Time:

Inspector:

MAINTENANCE ITEM	SATISFACTORY / UNSATISFACTORY	COMMENTS
1. Debris Cleanout (Monthly)		
Bioretention and contributing areas clean of debris		
No dumping of yard wastes into practice		
Litter (branches, etc.) have been removed		
2. Vegetation (Monthly)		
Plant height not less than design water depth		
Fertilized per specifications		
Plant composition according to approved plans		
No placement of inappropriate plants		
Grass height not greater than 6 inches		
No evidence of erosion		
3. Check Dams/Energy Dissipaters/Sumps (Annual, After Major Storms)		
No evidence of sediment buildup		

MAINTENANCE ITEM	SATISFACTORY / UNSATISFACTORY	COMMENTS
Sumps should not be more than 50% full of sediment		
No evidence of erosion at downstream toe of drop structure		
4. Dewatering (Monthly)		
Dewaters between storms		
No evidence of standing water		
5. Sediment Deposition (Annual)		
Swale clean of sediments		
Sediments should not be > 20% of swale design depth		
6. Outlet/Overflow Spillway (Annual, After Major Storms)		
Good condition, no need for repair		
No evidence of erosion		
No evidence of any blockages		
7. Integrity of Filter Bed (Annual)		
Filter bed has not been blocked or filled inappropriately		

Comments:

Actions to be Taken:

Appendix I

SEQR

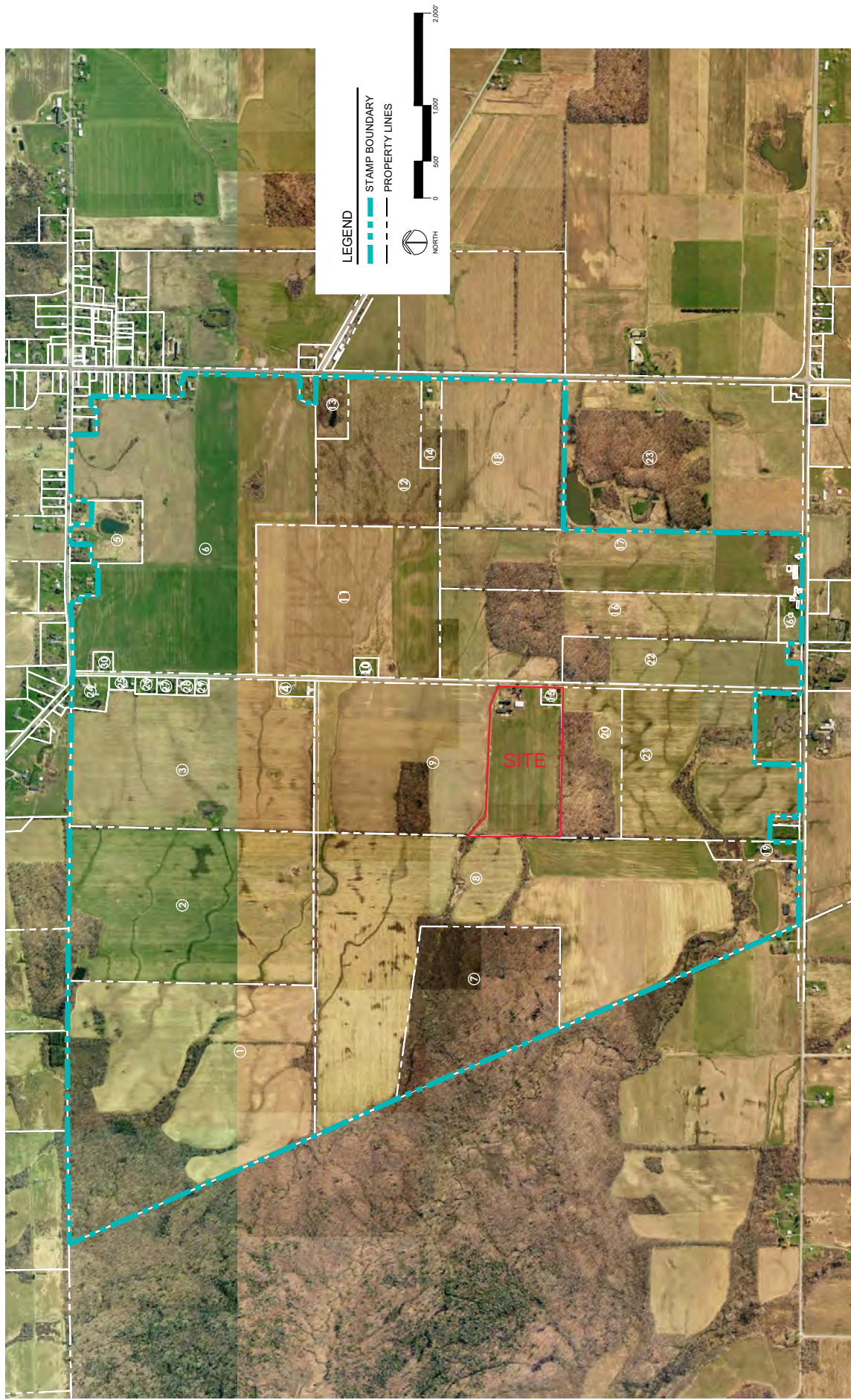

ATTACHMENT 2 - STAMP SITE PARCELS

WNY SCIENCE AND TECHNOLOGY ADVANCED MANUFACTURING PARK (STAMP)

FEBRUARY 2016

Attachment 1

STAMP Cultural Resource Investigation Status Table

2/23/2017

ON-SITE	COMPLETE	UNDERWAY	REQUIRED - PRIORITY	LOW PRIORITY	NOT REQUIRED	CLEARED	NOTES
Phase IA	Parcels 1-4, 6, 8-12, 14-18, 22-23, 25-26, 28-30	None	Parcels 5, 13, 20-21, 24, 27	Parcel 19	Parcel 7, 23	See Below	Remaining parcels are not currently owned by EDC. Parcel 7 is all wetland, no disturbance. Parcel 23 is no longer part of STAMP Site (John White MMA).
Phase IB	Parcels 1-4, 6, 8-12, 14-18, 22-23, 25-26, 28-30	None	Parcels 5, 13, 20-21, 24, 27	Parcel 19	Parcel 7, 23	Parcels 4, 9-10, 12, 14-15, 18, 22, 25-26, 28-30	27 Phase II Sites were identified during on-site Phase IB Investigation. Parcel 9 fully cleared when Phase III on Site 3 approved by SHPO
Phase II	Sites 3-7, 23	Sites 1-2, 8-15, 17-21, 24, 27	Underway	Underway	Sites 16, 22, 25	Sites 4, 7, 23	Fieldwork to be completed on all Phase II Sites currently underway in March 2017, reports by May 2017, Phase III Sites will be identified
Phase III	Sites 3 and 6	None	Site 5 and any resulting from Phase II Sites currently underway	None	None	None	Reports for Sites 3 and 6 currently being reviewed. A programmatic agreement may be required for final review and approval of data recovery at complete and future Phase III sites
OFF-SITE	COMPLETE	UNDERWAY	REQUIRED - PRIORITY	LOW PRIORITY	NOT REQUIRED	CLEARED	NOTES
Phase IA	Water Phase 1 and 2, Sanitary Sewer	None	None	None	None	See Below	
Phase IB	Water Phase 1	Water Phase 2 and Sanitary Sewer	None	None	None	Water Phase 1	Portions of Water Phase 2 and Sanitary Sewer require work on federal property, permitting ongoing, projected fieldwork in March 2017
Phase II			UNKNOWN	UNKNOWN	UNKNOWN		
Phase III			UNKNOWN	UNKNOWN	UNKNOWN		

See STAMP Cultural Resource Inventory Update Memo and Maps for details.

New York State Environmental Quality Review Act
Lead Agency Amended Findings Statement
for the
Western New York Science & Technology
Advanced Manufacturing Park (STAMP)
July, 2016

Town of Alabama
County of Genesee, New York

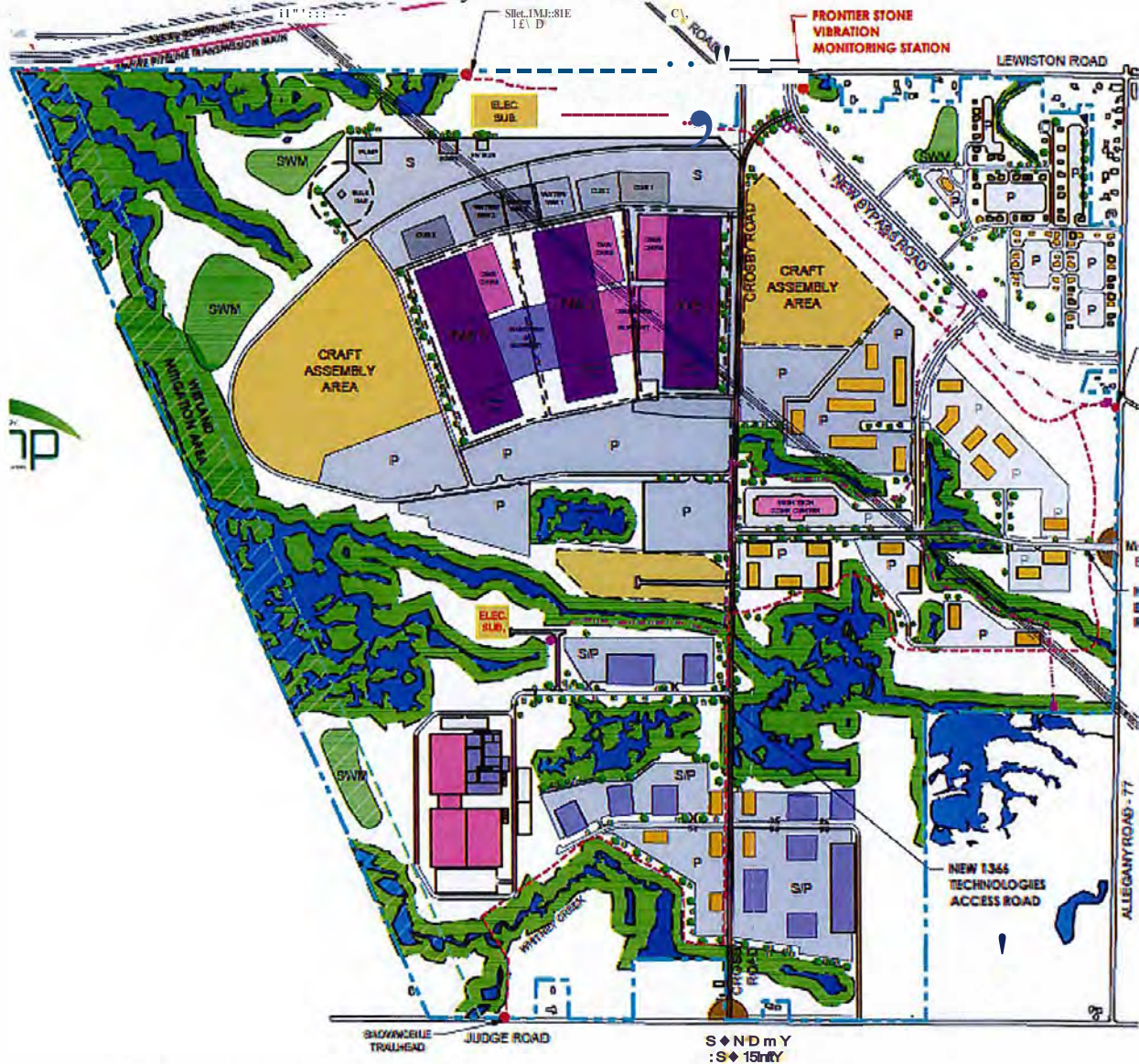

Lead Agency and Project Sponsor:
Genesee County Economic Development Center (GCEDC)



NEW YORK STATE ENVIRONMENTAL QUALITY REVIEW ACT

GENESEE COUNTY ECONOMIC DEVELOPMENT CENTER

AMENDED FINDINGS STATEMENT

**WESTERN NEW YORK SCIENCE & TECHNOLOGY
ADVANCED MANUFACTURING PARK (STAMP)**

This document is an amended Findings Statement prepared pursuant to the New York State Environmental Quality Review Act, Article 8 of the Environmental Conservation Law and the regulations promulgated thereto at 6 N.Y.C.R.R. Part 617 (collectively referred to as "SEQRA") by the Genesee County Industrial Development Agency d/b/a the Genesee County Economic Development Corporation ("GCEDC") as Lead Agency for the proposed Western New York Science & Technology Advanced Manufacturing Park ("STAMP" or the "Project") an advanced manufacturing technology campus on approximately 1,262 acres located on the west side of New York State Route 63/77, approximately five miles north of the I-90/New York State Thruway ("Site") in the Town of Alabama, New York ("Town"). The GCEDC is the Project Sponsor and hereby approves the Project as modified and recommits to undertaking the Project.

This Amended Findings Statement draws upon the matters set forth in the SEQRA record, including the generic environmental impact statement consisting of the Draft Generic Environmental Impact Statement ("DGEIS") accepted by the GCEDC on April 14, 2011, the Final Generic Environmental Impact Statement ("FGEIS") accepted by the GCEDC on January 19, 2012, as well as the public comments on the DGEIS received at the May 12, 2011 public hearing and during the public comment period which was conducted from April 21, 2011 through June 23, 2011. (Collectively, the DGEIS and the FGEIS are referred to as the "GEIS"). A smart growth impact statement pursuant to the State Smart Growth Public Infrastructure Policy Act was completed separately from the GEIS in February, 2012.

The purposes of the STAMP GEIS was to identify and evaluate the potential significant adverse environmental impacts of STAMP, compare the reasonable alternatives, and, where applicable, to identify reasonable mitigation measures to reduce the effect of those impacts to the maximum extent practicable, while weighing the substantial potential social and economic benefits of STAMP. The GCEDC, as lead agency, issued a written Findings Statement ("GCEDC Findings") on March 12, 2012 approving the Project and committing to undertake it.

There have been a number of changes contemplated to STAMP since the completion of the GEIS including changes to sewer service for STAMP (wastewater from STAMP will now be routed to the Village of Medina Waste Water Treatment Facility ("Medina WWTF")) and

revisions to the STAMP Master Plan (collectively, all changes are referred to as the "**Project Changes**"). In addition, 1366 Technologies Inc., ("**1366 Technologies**") has recently committed to become the first tenant of STAMP with the construction and operation of a large scale advanced manufacturing facility in the southwest corner of the Site ("**1366 Facility**"). Certain infrastructure including sewer, water, electrical and natural gas must be extended to the Site in conjunction with the 1366 Facility ("**STAMP Track I Infrastructure**").

In light of the proposed 1366 Facility and the Project Changes, the GCEDC has conducted an updated environmental review of the Project to determine whether the 1366 Facility and/or the Project Changes will result in any significant adverse environmental impacts which were not addressed in the GEIS or the GCEDC Findings ("**SEQRA Update**"). This process began with the GCEDC issuing notice of its intent to formally re-establish its Lead Agency status for the purpose of conducting this SEQRA Update in March, 2016. No interested or involved agencies objected to the GCEDC's intent to formally re-establish its Lead Agency status for the Project. Accordingly, the GCEDC became Lead Agency for purposes of this SEQRA Update in April, 2016.

The GCEDC Findings establish the procedures for the SEQRA Update. Specifically, the GCEDC Findings provide:

Final designs for less-defined Project components, as well as any proposed changes to the more well-defined elements (hereinafter referred to "Future Project Use(s)"), may require further evaluation pursuant to SEQRA. GCEDC, as lead agency, will be responsible for performing an environmental determination on Future Project Uses pursuant to SEQRA, and will consider Future Project Uses proposals in relation to: (i) the DGEIS; (ii) the FGEIS; and (iii) this Findings Statement.

Upon development of specific site plans, simultaneously with review by the Town of Alabama Planning Board for site plan approval, GCEDC shall determine if the environmental impacts associated with such Future Project Uses have been adequately addressed in the DGEIS, the FGEIS and this Findings Statement, taking into account whether the Future Project Uses exceed any of the thresholds set forth herein. Such a determination must be made before any site plans for Future Project Uses are approved by the Planning Board.

In the event that GCEDC determines that:

1. the Future Project Uses would be carried out in conformance with the conditions and thresholds set forth in this Section 10, then no further SEQRA compliance will be required;
2. the Future Project Uses would be carried out in conformance with the conditions and thresholds set forth in this Section 10, but are not addressed or are not adequately addressed in the DGEIS, the FGEIS or this Findings Statement, then an amended Findings Statement will be prepared;
3. the Future Project Uses are not addressed or are not adequately addressed in the DGEIS, the FGEIS or this Findings Statement, but the proposal does not exceed any of the conditions or thresholds set forth in this Section 10, or the proposal does exceed a threshold set forth in this Section 10, but would not result in any

- potential significant adverse environmental impacts, then a Negative Declaration will be prepared pursuant to 6 N.Y.C.R.R. § 617.10(d)(3); or
4. the Future Project Uses are not addressed or are not adequately addressed in the DGEIS, the FGEIS or this Findings Statement for the Project and/or the proposed use would exceed the conditions or thresholds set forth in this Section 10 and may have one or more potential significant adverse environmental impacts, then a supplement to the FGEIS will be prepared.

A. Description of Action

1. GEIS Project Description

Per the FGEIS and the GCEDC Findings, STAMP was proposed to be located on 1,243.40 acres of land. STAMP's GEIS master plan ("**GEIS Master Plan**") provided for the development of a high technology campus accommodating over 6 million square feet of advanced technology manufacturing and related uses providing direct employment of an estimated 9,330 people. Phase 1 of the GEIS Master Plan involved attempting to attract an anchor tenant technology manufacturing facility comprised of approximately 1 million square feet.

Per the FGEIS and the GCEDC Findings, the basic and overall purpose of the Project was defined as the development of an advanced manufacturing technology center in Genesee County ("**County**"). The Project was designed to target green-technology and advanced manufacturing companies involved in developing and manufacturing clean technology, renewable energy and/or energy efficient products. These companies were to include semi-conductor manufacturers, photovoltaic solar cell manufacturers, flat panel display manufacturers including medical imaging display, bio-pharmaceutical/ nanotechnology-enabled industries, and green technology research and development for energy efficient building products.

2. 1366 Technologies

As mentioned earlier, STAMP has secured its first tenant for the Project, 1366 Technologies, which plans to construct a large scale commercial manufacturing facility that will use a proprietary manufacturing process for making silicon wafers, whereby they produce multi-crystalline silicon wafers for solar cells at substantially lower costs and with less waste than current processes. Since silicon wafers are the largest cost component in the manufacture of silicon photovoltaic modules used in solar cells, this new process is anticipated to reduce the overall cost of solar power.

The 1366 Facility will be located in the southwest corner of the Site on a 105-acre site ("**1366 Parcels**") which includes 41.1 acres of buildable area. The 1366 Facility is proposed to be built-out in phases. The first phase will include an approximate 150,000+/- sf facility that will initially produce 250MW of silicon wafers annually. The 1366 Facility would be quickly expanded over several years to allow for growth to 600,000+/- square feet to allow for 1 GW of silicon wafer production annually with up to 1,000 employees and approximately \$700 million in total investment.

The 1366 Facility will be constructed, in part, with loan guarantees from the USDOE. The initial phase of the 1366 Facility is anticipated to commence operation in 2017, with full project build out expected by 2021.

3. Contemplated Project Changes Since 2012

As noted above, since the completion of the GEIS process in 2012, there have been a number of Project Changes summarized below.

a. **Master Plan Changes/Updates**

Since the completion of the GEIS, there have been a number of changes developed to the GEIS Master Plan as reflected in an updated master plan ("**Updated Master Plan**") which retains the large green buffer around the majority of the perimeter of the Site and preservation of natural features across the Site within three different zones of development connected by internal walking/biking trails. In the Update Master Plan, more refinement has been added to the layout for the Fabs Complex and the 1366 Facility has been added to the campus in the southwest quadrant of the Site. Specific changes are described below.

(1) **Changes to the Site Plan Layout**

There are four major changes to the Site Plan layout as reflected in the Updated Master Plan. The first involves reductions in on-Site impacts to aquatic resources. Wetland impacts have been reduced to approximately 4.48 acres of federally regulated wetlands and 3.34 of non-jurisdictional wetlands (total of 7.82 acres). On-Site stream corridor impacts have also been reduced from 9,595 linear feet to approximately 9,446 linear feet.

The second change involves utility re-routing. The existing 115 kV power line that traverses the Site (from northwest quadrant to southeast/central area of Site) will be relocated to the perimeter of the Site. Electric service to 1366 Technologies will be run from the existing line south of the new access road into the Site from Route 63/77 ("Main Access Road") to the proposed electric substation north of the 1366 Parcels. Also, natural gas and sewer will be brought into the Site along the future Bypass Road/Connector Road right-of-way.

The third change involves realignment of the Main Access Road into the Site which has been straightened somewhat to run more directly to Crosby Road. This shift minimizes wetland impacts (.23 acres) while allowing for a larger development footprint north of the Main Access Road on the west side of Crosby Road.

The fourth change involves the relocation of the Bypass Road and realignment of the Connector Road between the Bypass Road and the Main Access Road. The Bypass Road has been moved southwest to a flat area atop the ridge line that runs along the northeast quadrant of the Site. These realignments result in a small expansion of TD3 and slight reduction to TD1 and TD2.

(2) **Changes to the TD Zoning Boundaries, Buffers and Regulations**

The GCEDC has proposed modifications to the TD zoning regulations to clarify the intent of the Town of Alabama Town Board ("Town Board") with regard to zoning for the Site including: buffer use clarifications, the elimination of the 300-foot buffer along the northern side of the Site, the elimination of the 300-foot buffer on the interior of the Site between TD1/TD2 and TD3, the elimination of the 300-foot buffer for 500 linear feet on each side of the Main Access Road and that this area be zoned TD2, and the addition of solar panels as a special use permit in TD1 and TD2. The GCEDC is proposing some minor changes to the TD district lines.

(3) **Timing and Other Changes to the GEIS Master Plan**

There are a number of other changes contemplated to the GEIS Master Plan. First, the GCEDC is accelerating the construction of this Main Access Road which will be completed in conjunction with the development of the 1366 Facility. In addition, the GCEDC has expanded the footprint of the Site to include all of the residential properties in the north-central area of STAMP along Crosby Road (except for the northern-most parcel at the intersection of Crosby Road and Lewiston Road). With these changes, the Site is now 1,262 acres. The GCEDC has requested that the Town Board rezone these residential parcels to TD1.

b. Demolition of the Houses Along Crosby Road

As a result of the expansion of the footprint of the Site to include all of the residential properties in the north-central section of STAMP along Crosby Road, six additional existing houses on Crosby Road are now proposed for demolition following acquisition by the GCEDC.

c. The Town Water Project

In order to extend water service to the Site, the GCEDC has entered into the Incentive Zoning Agreement ("IZA") with the Town, which, among other things, commits the GCEDC to design and install the a municipal water project ("Town Water Project") which has a currently estimated capital cost of \$7,824,570 and will serve approximately 433 households in the Town. The GCEDC has agreed to include the Town Water Project within the scope of this SEQR Update.

d. Water Service for STAMP

Water required for the Project will be provided to the Site via a new 12 inch transmission water main to be constructed along Judge Road and a portion of Route 63/77 between the Village of Oakfield and the Site. This main will be constructed in conjunction with the Town Water Project and will be owned and maintained by the Town.

e. Sewer Service for STAMP

The Village of Medina Wastewater Treatment Facility ("**Medina WWTF**") has been selected as the preferred sanitary sewer effluent treatment alternative. The Medina WWTF is approximately twelve miles north of the STAMP, and the route from the STAMP site to the Village of Medina has been established with input from the Village of Medina, Orleans County and the Town of Shelby. The Medina WWTF can handle approximately 1 MGD of sewage from

STAMP without significant upgrades to its treatment plant. Ultimately, with upgrades, it is anticipated that the Medina WWTF would be able to handle up to 2.5 MGD of sewage from STAMP.

f. The Northern Long Eared Bat

The northern long-eared bat ("**NLE Bat**") has recently been listed as a Threatened Species under State and Federal law. Potential impacts to the NLE Bat are being re-evaluated based on this species new listing as a Threatened Species.

B. Analysis of Environmental Impacts

This section provides an analysis of the environmental impacts of the 1366 Facility and the Project Changes relative to the environmental impacts identified and analyzed in the DGEIS, the FGEIS and the GCEDC's Findings (collectively referred to herein as "**GEIS/Findings**").

1. Impacts on Geology and Topography

a. The 1366 Facility

Because the 1366 Parcels and surrounding area are generally flat, consistent with the analysis in the GEIS/Findings, construction of the 1366 Facility and related infrastructure improvements will not require major alterations to the natural topography of the 1366 Parcels. Some of the topography on the Site will require slight grading and redistribution of soil material. Consistent with the GEIS/Findings, grading is anticipated to be balanced such that the amount of cut required by the development of the 1366 Facility and related infrastructure improvements will be approximately equal to the amount of fill required. Accordingly, the impacts to geology and topography from the construction and operation of the 1366 Facility and related infrastructure improvements are adequately addressed in the GEIS/Findings.

b. The Project Changes

(1) Master Plan Changes/Updates

Generally, there are no material impacts to geology and topography associated with the Master Plan Changes/Updates. The changes to the utility runs and the realignment of both the Main Access Road and Bypass Road will result in minor changes to grading plans on-Site as physical improvements are relocated. However, these changes will reduce earthwork and soil disturbance at the Site. Similarly, adjustments to the zoning regulations may result in minor changes to grading plans on-Site as some boundaries and buffers are reduced and/or relocated. The inclusion of the residential properties on the north end of Crosby Road will result in minor changes to grading plans on-Site as physical improvements are relocated. All of these changes are minor and well within the scope of actions analyzed in the GEIS/Findings.

(2) Demolition of the Houses Along Crosby Road

There are no material impacts to geology and topography associated with the demolition of the houses along Crosby Road that were not addressed in the GEIS/Findings. Following the completion of demolition, each house site will be appropriately re-graded with no anticipated changes to topography. To the extent any of the houses have basements, any subsurface improvements will be removed, and clean fill will be added to ensure level grading.

(3) The Town Water Project

There are no material impacts to geology and topography associated with the Town Water Project that were not addressed in the GEIS/Findings. Installation of water related infrastructure will be along public roads via a combination of open cut method and directional drill method. These installations will result in temporary impacts to geography and topography that were analyzed in the GEIS/Findings.

(4) Water Service for STAMP

There are no material impacts to geology and topography associated with water service for STAMP that were not addressed in the GEIS/Findings. As with the Town Water Project, on-Site installation of water related infrastructure will be along current and/or future roads via a combination of open cut method and directional drill method. These installations will result in temporary impacts that were analyzed in the GEIS/Findings.

(5) Sewer Service for STAMP

There are no material impacts to geology and topography associated with sewer service for STAMP that were not addressed in the GEIS/Findings. Installation of sewer related infrastructure will be along public roads via a combination of open cut method and directional drill method. However, all installation routes will be re-graded to match original topography after infrastructure installation. Thus, these installations will result in temporary impacts that are consistent with impacts from other infrastructure installations that were analyzed in the GEIS/Findings.

2. Impacts on Water Resources

a. The 1366 Facility

Construction of the 1366 Facility and related infrastructure improvements will avoid any physical disturbance of surface water resources, including Whitney Creek and the three jurisdictional wetlands on the 1366 Parcels. Moreover, all of these surface waters present on the 1366 Parcels, plus a 100 foot buffer, will be deed restricted to prevent future development.

Construction will require the clearing and filling of portions of the Site which will expose un-vegetated soil to the elements. This creates the potential for erosion and sedimentation due to storm water passing through un-vegetated areas or construction areas with exposed soils, which could result in degradation of water quality in Whitney Creek and other surface waters in the

area. Consistent with the analysis in the DGEIS/Findings, best management practices will be employed to minimize impacts to streams and other water resources during construction and operation of the 1366 Facility. In addition, as required by the *New York Stormwater Management Design Manual* (January 2015), one or more point source treatment practices, such as rain gardens for roof drainage, bio-retention swales, or infiltration trenches for parking areas, and a variety of other practices, shall be incorporated into the design of the 1366 Facility.

b. The Project Changes

(1) Master Plan Changes/Updates

The STAMP Updated Master Plan shows a reduction in wetland impacts as compared to the GEIS Master Plan. Accordingly, the impacts to water resources from the changes to the Master Plan Changes/Updates are adequately addressed in the GEIS/Findings.

(2) Demolition of the Houses Along Crosby Road

There are no material impacts to water resources associated with the demolition of the houses along Crosby Road that were not addressed in the GEIS/Findings. These houses are not proximate to any water resources.

(3) The Town Water Project

There are no material impacts to water resources associated with the Town Water Project that were not addressed in the GEIS/Findings. In terms any potential impact due to construction activities, directional drilling will be implemented on any stream or wetland crossing, and a SWPPP will discuss plans for any trenching and erosion control details.

(4) Water Service for STAMP

There are no material impacts to water resources associated with water service for STAMP that were not addressed in the GEIS/Findings.

(5) Sewer Service for STAMP

The sewer line to Medina will cross the Iroquois National Wildlife Refuge along the Route 63 public right-of-way. This area has large wetlands and several stream crossings. In order to ensure protection of water resources, the GCEDC will employ directional drilling methods. Based on existing soils conditions and the physical limitations with the directional drill equipment, each directional drill set up will be staged a maximum of approximately 1,000 feet. The force main will be installed by directional drill method between each staging area. Thus, the installation of the sewer main will have minimal temporary impacts to less than 0.5 acre of wetland and will not adversely impact water resources along the installation route. If anything, the routing of sewer lines to the Medina WWTF will be beneficial to local water resources by removing proposed treated discharges from nearby streams, including Whitney Creek, Tonawanda Creek, Oak Orchard Creek and/or other small tributaries in the area.

3. **Impacts on Air Resources**

a. **The 1366 Facility**

The 1366 Facility will require a State Facility Permit from NYSDEC, and therefore, must satisfy the requirements set forth in the GEIS/Findings including NYSDEC's Air Guide-1, which was developed to evaluate the short-term and annual impacts from sources of air emissions in the state. The 1366 Facility will include state-of-the-art emission control equipment as a necessary function of its operations, as determined by the State Air Permit. Air Emission Scrubbing will take the form of a wet scrubber installed to treat hazardous and environmental gas emissions from certain processes. Further, all equipment using hazardous gases is designed to fail into a safe state, preventing emissions. Overall emissions of air pollutants from the 1366 Facility will comply with the thresholds for air emissions set forth in the GEIS/Findings.

b. **The Project Changes**

(1) **Master Plan Changes/Updates**

The Master Plan Changes/Updates have no impacts upon air resources. These changes do not result in larger developable areas or more building square footages. In fact, open space actually increases under the Updated Master Plan. Further, the building square footage threshold established in the GEIS/Findings (6,130,000 sf) has not changed.

(2) **Demolition of the Houses Along Crosby Road**

There will be minor temporary impacts to air resources associated with the demolition of the houses along Crosby Road. These impacts will be minimized through the utilization of appropriate dust control measures including wetting of materials during demolition consistent with construction related impacts associated with the demolition of other structures on-Site addressed in the GEIS/Findings.

(3) **Town Water /STAMP Water & Sewer Service**

There are no material impacts to air resources associated with the Town Water Project and/or water or sewer service for STAMP that were not addressed in the GEIS/Findings.

4. **Impacts on Terrestrial and Aquatic Ecology**

a. **The 1366 Facility**

The 1366 Facility will replace active agricultural fields with a high-technology manufacturing plant and supporting facilities, such as access roads and parking lots, utilities, etc. However, existing forested areas adjacent to the 1366 Parcels, such as the riparian forest adjacent to Whitney Creek, and wetland areas will be preserved along with a 100-foot buffer. Although limited tree cutting may be required on the 1366 Parcels, tree plantings of native species will be included as part of the overall landscaping of the 1366 Parcels, leading to a net increase in the number of trees. Finally, GCEDC is proposing deed restrictions and/or conservation easements

to further protect wetlands in accordance with the goals and policies of the STAMP Long-Term Land Management Plan ("LTMP"). Accordingly, the impacts to terrestrial and aquatic ecology from the construction and operation of the 1366 Facility and related infrastructure improvements are adequately addressed in the GEIS/Findings..!

b. The Project Changes

(1) Master Plan Changes/Updates

As discussed above in the water resources analysis, the overall changes to the Master Plan Changes/Updates in a net reduction in wetland and aquatic resource impacts from the scope of actions analyzed in the GEIS/Findings. Additionally, these changes do not result in larger developable areas or more building square footages.

(2) Demolition of the Houses Along Crosby Road

There are no material impacts to terrestrial and aquatic ecology associated with the demolition of the houses along Crosby Road that were not addressed in the GEIS/Findings.

(3) The Town Water Project

There are no material impacts to terrestrial and aquatic ecology associated with the Town Water Project that were not addressed in the GEIS/Findings. Any potential impacts to terrestrial and aquatic ecology due to construction activities in connection with the Town Water Project will be minor, and temporary in nature.

(4) Water Service for STAMP

There are no material impacts to terrestrial and aquatic ecology associated with water service for STAMP that were not addressed in the GEIS/Findings. Accordingly, the impacts to terrestrial and aquatic ecology from water service for STAMP are adequately addressed in the GEIS/Findings.

(5) Sewer Service for STAMP

There are generally no material impacts to terrestrial and aquatic ecology associated with the sewer service for STAMP that were not addressed in the GEIS/Findings. One exception to this general characterization of aquatic resources within the sewer route is Oak Orchard Creek and the associated wetlands to the south of Oak Orchard Creek's intersection with Route 63. This wetland area is owned by USFWS (Iroquois National Wildlife Refuge) and is part of a large complex system that includes riparian, emergent, and forested wetlands. While evidence of disturbance exists, the system as a whole is high quality, federally protected, and linked to mapped significant natural communities and potential occurrence of rare, threatened, and endangered species. The sewer project will disturb only areas within and/or immediately

¹ Please note, potential impacts to the NLE Bat are addressed in a separate analysis herein.

adjacent to an existing DOT right-of-way. Wetlands within or adjacent to this proposed area of disturbance are fragmented edges of the larger system.

In order to ensure the construction of the sewer line across the Iroquois National Wildlife Refuge along the Route 63 public right-of-way will not adversely impact these resources, the force main will be installed by directional drill method which will limit ground disturbance and potential impacts significantly. Accordingly, any potential impacts to terrestrial and aquatic ecology due to construction activities in connection with the Sewer Service for STAMP will be minor, and temporary in nature.

c. The Northern Long Eared Bat

As discussed above, the NLE Bat has recently been listed as a Threatened Species under State and Federal law and potential NLE Bat habitat is present at the Site and within the offsite utility Project areas. A field review of on-Site habitat suitable for the NLE Bat was conducted in November, 2015, taking into account areas of potential disturbance associated with construction planned for the 1366 Facility, including construction of the entry road, substation and utility areas. Project activities require the removal of trees greater than 3" DBH along the first section of the proposed access road west of Route 63/77, where hedgerows are crossed by the access roads and utilities, and along Crosby Road on residential parcels.

Additional field review was conducted at the site in May, 2016. A Phase 1 Summer Habitat Assessment was completed including data collection at a representative sample sites. Very few trees within the Project area are ideally suited for summer bat habitat due to a paucity of trees with exfoliating bark and no suitable snags. Further, the Project area is not near known maternity sites and are not located within 0.25 mile of a known hibernaculum according to a review of known sites.

To ensure that the future development activities will not have any material impacts to the NLE Bat, any necessary tree removal will be scheduled outside of the pup season (June 1-July 31) and, where possible, within the hibernation period (October 31 - March 31). The Project location and planned construction schedule put the Project within the category of "excepted from incidental taking prohibitions" in the final 4(d) rule. In this case, the determination is that activities "may affect" but are not likely to adversely affect and/or will not cause a prohibited taking. Thus, future on-Site development activities will not have an adverse impact upon the NLE Bat and the listing of the NLE Bat as a Threatened Species under State and Federal law will have no material impacts to terrestrial and aquatic ecology in conjunction with the Project.

In terms of off-Site development associated with water and sewer infrastructure, a desktop and field review were conducted in December, 2015 and May, 2016 in support of the development of an aquatic resource and ecology investigation report.

The majority of the off-site infrastructure (water and sewer) project areas are upland consisting of previously disturbed areas including road shoulders, mowed lawn and mowed lawn with trees, cropland, excavated ditches, culverts, and brushy cleared land. A smaller portion of the project area, primarily at stream and wetland crossings, consists of intermittent and perennial

streams and wetlands. One exception to this general characterization of aquatic resources within the sewer route is Oak Orchard Creek and the associated wetlands to the south of Oak Orchard Creek's intersection with Route 63.

To ensure that the installation of the off-site infrastructure will not have any material impacts to the NLE Bat, any necessary tree removal will be scheduled outside of the pup season (June 1 - July 31) and, where possible, within the hibernation period (October 31 - March 31). The Site location and planned construction schedule put the Project within the category of "excepted from incidental taking prohibitions" in the final 4(d) rule. In this case, the determination is that activities "may affect" but are not likely to adversely affect and/or will not cause a prohibited taking. Thus, the installation of the off-site infrastructure will not have an adverse impact upon the NLE Bat.

5. **Impacts on Technology Industry Health and Safety**

a. **The 1366 Facility**

Several plans for chemical storage/ handling may be required for the 1366 Facility including:

- Small Quantity Generators or Large Quantity Generators permit from NYSDEC for hazardous waste.
- USEPA Hazardous Waste Registration with NYSDEC.
- Emergency Planning and Community Right-to-Know Act.
- SARA Title III Inventory Reporting.
- EPCRA Toxic Release Reporting (Form R).
- NYSDOT Hazmat Registration and Security Plan.
- Flammable storage and use permits from local fire departments.

1366 Technologies will provide a Hazardous Materials Inventory Statement and a 1366 Facility Specific Hazardous Materials Management Plan to the Town of Alabama Fire Department. Additionally, all hazardous materials at the 1366 Facility will be transported, handled, stored and disposed of in accordance with:

- Applicable requirements set forth in the Hazardous Substance Bulk Storage Program and/or the Petroleum Bulk Storage Program.
- Applicable requirements set forth in all DOT requirements.
- Applicable SPCC rules.
- Applicable requirements of the Uniform Fire and Building Codes.
- Applicable OSHA and/or RCRA regulations.

b. **The Project Changes**

(1) **Master Plan Changes/Updates**

There are no Master Plan Changes/Updates that will impact technology industry health and safety.

(2) Demolition of the Houses Along Crosby Road

There are no material impacts to health and safety associated with the demolition of the houses along Crosby Road that were not addressed in the GEIS/Findings. All asbestos and other potentially hazardous materials, such as mercury thermostats, fluorescent lights or miscellaneous cleaners, will be removed from the structures prior to demolition, properly packaged and disposed of in accordance with applicable laws. Demolition contractors will employ wet methods and other engineering controls during demolition to minimize airborne particulate emissions. The GCEDC will comply with all applicable laws and will implement proper protocols during the demolition period to minimize potential impacts from demolition activities.

(3) Town Water /STAMP Water & Sewer Service

There are no material impacts to health and safety associated with the Town Water Project, water service for STAMP and/or sewer service for STAMP that were not addressed in the GEIS/Findings.

6. Impacts on Traffic and Transportation

a. The 1366 Facility

Transportation access to the 1366 Parcels will be via an access road to Crosby Road (secondary access), with a main access to/from NY State Route 63/77. At full build out (1 GW), the 1366 Facility will generate an average of 2,486 trips per day including 86 truck trips per day, and will operate 24 hours a day, 7 days a week.

For the initial phase of development of the 1366 Facility (250 MW), the 1366 Facility will generate an average of 622 trips per day including 22 truck trips per day. The highest anticipated peak hour for the initial phase is approximately 240 trips per hour. Based on these traffic estimates, the Phase I build out of 1366 Technologies will result in less traffic than the Phase I build out assumed in the GEIS, however, its full build out will be more than the Phase I GEIS build out. Full build out will still remain below the 70% threshold.

An updated traffic impact analysis was conducted because of the acceleration of the installation of the Main Access Road. Instead of utilizing two access point at either end of Crosby Road to enter the Site, the acceleration of the construction of the Main Access Road means that traffic entering the Site will be through a single entry point. The updated Traffic Impact Analysis concluded that a left turn lane on Route 63/ 77 to access the Site is warranted. Thus, a northbound left turn lane on Route 63/ 77 will be implemented. This turn lane was identified as a necessary future improvement in the GEIS/Findings.

b. The Project Changes

(1) Master Plan Changes/Updates

The realignment of the Bypass Road will improve traffic flow due to better intersection designs. The other changes to the site plan layout do not result in larger developable areas or more building square footages. Further, the building square footage threshold established in the GEIS/Findings (6,130,000 sf) has not changed.

(2) Demolition of the Houses Along Crosby Road

There are no material impacts to traffic and transportation associated with the demolition of the houses along Crosby Road that were not addressed in the GEIS/Findings.

(3) Town Water /STAMP Water & Sewer Service

The construction and excavation work associated with the installation of the water and sewer mains and related facilities will require the transportation of construction materials, including loads of water piping, gravel, topsoil and related construction materials. There will also be minor impacts because the water infrastructure will be installed within existing road right-of-ways requiring lane closures and traffic re-routing. These impacts will be minor and temporary and are within the scope of construction activities analyzed in the GEIS/Findings.

7. Impacts to Land Use and Zoning

a. The 1366 Facility

The construction of the 1366 Facility and related infrastructure improvements will convert existing croplands within a portion of the Site into a modern, high-technology manufacturing facility and related support infrastructure. The 1366 Parcels are approximately 105 acres in size. A large percentage of the 1366 Parcels will be preserved for open space, consisting of landscaping and protection of environmentally-sensitive resources. The entire Site has been rezoned by the Town Board to TDI to accommodate the kinds of development (advanced high technology and research focused on renewable energy) envisioned for STAMP, such as the 1366 Facility. The 1366 Facility will be developed pursuant to and consistent with the TDI requirements as established under the IZA with the Town. Further, the 1366 Facility will comply with all zoning regulations in TDI such as minimum lot size, maximum building height, maximum lot coverage, parking requirements and signage requirements.

b. The Project Changes

(1) Master Plan Changes/Updates

In terms of changes to the site plan layout, the realignment of the Bypass Road and the connector road to the Main Access Road will have a small impact on land use and zoning. Specifically, TD3 will increase in size from approximately 72.3 acres to 89.4 while TDI and TD2 will decrease in size. However, the density of the build out in each of the districts will not change.

In terms of the buffer use clarifications, all of the uses included in the clarifications were identified as permitted uses in the GEIS/Findings. Thus, there are no impacts to land use and zoning from the buffer use clarifications that were not analyzed and addressed in the GEIS/Findings.

In terms of the elimination of the 300-foot buffer along the northern side of the Site, this area is already buffered from public rights-of-way by adjacent agricultural lands and utility infrastructure. Thus, there are no impacts to land use and zoning from the buffer use clarifications that were not analyzed and addressed in the GEIS/Findings.

In terms of the elimination of the 300-foot buffer on the interior of the Site between TD1/TD2 and TD3, this change creates the possibility of a minor visual impact to the Hamlet as buildings at the top of the ridgeline, which is within the buffer area, may be visible to the Hamlet. In order to address and mitigate this, the GCEDC is proposing new minimum setbacks from the Bypass Road, which has been relocated atop the ridgeline, to ensure that buildings are adequately setback from the ridgeline. The new setbacks along the Bypass Road are actually more restrictive than the current buffer, except for a very small area, approximately 1.3 acres, in the area where the Bypass Road meets Lewiston Road.

In terms of the elimination of the 300-foot buffer for 500 linear feet on each side of the Main Access Road, this too, will create visual impacts as structures associated with the Project are developed along Route 63/77. In order to mitigate this issue, the GCEDC and the Town have agreed to work together on revised design guidelines for this area to ensure the construction of high quality, attractive buildings.

In terms of adding solar panels as a special use permit in TD1 and TD2, this change will have no significant impact on land use or zoning, particularly because it is simply adding to the previously included cell towers and windmills as other uses by special use permits.

In terms of the addition of the residential houses on the north end of Crosby Road, this change will result in an important but minor change to land use in the overall context of the Project. Specifically, these properties will be rezoned from A-R to TD1. With the exception of one property along Lewiston Road, all of the properties along Crosby have been/will be acquired and demolished. At the request of the Town, a setback of 30 feet from Crosby Road for construction of new structures within the area to be rezoned will be established.

c. Demolition of the Houses Along Crosby Road

The demolition of the houses along Crosby Road will result in permanent conversion of each of the six {6} parcels of land from residential use to technology manufacturing. This will result in an important but minor change to land use in the overall context of the Project.

d. The Town Water Project

There are no material impacts to land use and zoning associated with the Town Water Project that were not addressed in the GEIS/Findings. It is, however noted, that the Town Water

Project is being fully paid for by funds secured by the GCEDC per the terms of the IZA. This funding obligation was discussed extensively in the GEIS/Findings.

e. STAMP Water & Sewer Service

There are no material impacts to land use and zoning associated with water service and/or sewer service for STAMP that were not addressed in the GEIS/Findings.

8. **Impacts to Utilities**

a. The 1366 Facility

Although the plans for providing Phase 1 water and sewer for the Project have changed since the completion of the GEIS/Findings, the utility needs for the 1366 Facility are well within the thresholds analyzed in the GEIS/Findings and which are currently available. Specifically, the GEIS/Findings analyzed obtaining up to 3 MGD of water from the County and 1366 Technologies' water consumption needs will not exceed 800,000 GPD. In terms of sewer, the Medina WWTF can handle approximately 1 MGD without any significant upgrades and 1366 Technologies' sewer needs will not exceed 600,000 GPD. Additionally, electric, gas and telecom infrastructure will be sufficient with the extensions to the Site identified in the GEIS/Findings, to meet the needs of the 1366 Facility.

b. The Project Changes

(1) Master Plan Changes/Updates

The Master Plan Changes/Updates will not result in larger developable areas or more building square footages. While the utility rerouting portion of the site plan changes will have an impact upon the physical location of utility corridors, there are no impacts to utilities associated with the utility rerouting.

(2) Demolition of the Houses Along Crosby Road

There are no material impacts to utilities associated with the demolition of the houses along Crosby Road that were not addressed in the GEIS/Findings.

(3) The Town Water Project

Adequate water volumes for the long-planned Town Water Project are available from Genesee County. The Town system and STAMP are being designed to provide at a minimum, 100,000 GPD for the Town, 150,000 GPD to Lamb Farms, and 200,000 GPD for the STAMP Site totaling 450,000 GPD. Supply needs significantly higher than 450,000 GPD will require construction of an additional transmission main to Pembroke, consistent with the analysis in the GEIS/Findings and as recently confirmed with Genesee County.

(4) Water Service for STAMP

Consistent with the Water Service Preliminary Report, attached as *Appendix N* to the DGEIS, a phased approach to water supply is being applied at STAMP. Also, consistent with the Water

Service Preliminary Report, water supply for Phase 1 of STAMP (1 MGD) will be supplied by Genesee County.

(5) **Sewer Service for STAMP**

The Medina WWTF is currently permitted for 4.5 MGD of capacity while actual discharges average between 1.5 MGD and 2.2 MGD. A detailed peak flow analysis was undertaken which confirms that the Medina WWTF has capacity to accommodate an additional 1 MGD.

9. **Impacts to Community Facilities**

a. **The 1366 Facility**

The 1366 Facility will maintain its own internal fire suppression system that will consist of wet sprinkler systems, foam fire suppression system, clean agent style fire suppression system, early suppression, fast response system, deflagration venting, smoke control, toxic/ flammable gas detection system, on-site fire hydrants, and fire department hose valves. Based upon available information, the Alabama Fire Department ("**AFD**") will not require additional resources to protect the 1366 Facility; however, periodic training will be provided to volunteers of the AFD and other pertinent emergency service providers regarding responding to any emergency calls from the 1366 Facility and chemical-specific aspects of the facility. This kind of coordination and training is routinely provided by technology manufacturing companies and is consistent with analysis provided in the GEIS/Findings.

In terms of waste generation, the 1366 Facility will not exceed volumes analyzed in the GEIS/Findings. In terms of impacts to public lands and recreation, for the reasons identified in the GEIS/Findings, the 1366 Facility will not have an impact upon open space or recreation.

In terms of an emergency action plan, 1366 Technologies' emergency action plan will be prepared and submitted to the Town in conjunction with 1366 Technologies' site plan application. This approach is consistent with the requirements set out in both the GCEDC Findings, the Town Board Findings and the Emergency Services Impact Analysis, and will ensure no impacts to emergency services that were not previously addressed in the GEIS/Findings.

b. **The Project Changes**

(1) **Master Plan Changes/Updates**

There are no Master Plan Changes/Updates that will impact community facilities. The site plan changes do not result in larger developable areas or increased building square footages. In addition, the Town will have no responsibility for maintaining any portion of the Site.

(2) **Demolition of the Houses Along Crosby Road**

There will be a relatively small volume of construction and demolition debris generated by the demolition of the houses along the north end Crosby Road and their supporting structures, but all construction and demolition waste will be properly disposed of at approved disposal facilities.

(3) The Town Water Project

There are no material impacts to community facilities associated with the Town Water Project that were not addressed in the GEIS/Findings.

(4) Water Service for STAMP

There are no material impacts to community facilities associated with water service for STAMP that were not addressed in the GEIS/Findings.

(5) Sewer Service for STAMP

There are no material impacts to community facilities associated with sewer service for STAMP. The Medina WWTF is currently permitted for 4.5 MGD of capacity. Actual discharges average between 1.5 MGD and 2.2 MGD. A detailed peak flow analysis was undertaken to confirm that the Medina WWTF has the capacity to treat up to 1 MGD of wastewater from STAMP during peak periods. Flow monitoring for sections of the Village of Medina was implemented during the sanitary sewer route analysis.

10. **Impacts to Community Character and Demographics**

a. Aesthetics

(1) The 1366 Facility

The 1366 Facility and related infrastructure improvements will be designed and constructed in a low density setting consistent with the design philosophy of STAMP and will be constructed consistent with existing STAMP design guidelines. The required 400-foot buffer will be maintained along the western boundary of the 1366 Parcels to ensure adequate screening on the 1366 Facility from the lands of the Tonawanda Seneca Nation ("Nation"). Existing hedgerows on the Site will generally be maintained and will help ensure that the 1366 Facility is not materially visible from any existing public rights of way. In addition, all exterior lighting for the 1366 Facility will be directed downward to minimize the amount of light that spills beyond the boundaries of the 1366 Parcels.

(2) The Project Changes

(i) Master Plan Changes/Updates

The Main Access Road into the Site from Route 63/77 had a significant curve to the north in the GEIS Master Plan. In the Updated Master Plan, the alignment has been straightened somewhat to run more directly to Crosby Road. Nonetheless, a curve in the Main Access Road has been maintained to provide a more interesting visual context from the Main Access Road entrance looking towards the interior of the Site.

The elimination of the 300-foot buffer on the interior of the Site between TD1/TD2 and TD3, creates the possibility of a minor visual impact to the Hamlet as buildings at the top of the ridgeline, which is within the buffer area, may be visible to the Hamlet. In order to address and mitigate this, the GCEDC is proposing new minimum setbacks from the Bypass Road, which has

been relocated atop the ridgeline, to ensure that buildings are adequately setback from the ridgeline. The new setbacks along the Bypass Road are actually more restrictive than the current buffer, except for a very small area, approximately 1.3 acres, in the area where the Bypass Road meets Lewiston Road.

The elimination of the 300-foot buffer for 500 linear feet on each side of the Main Access Road will create visual impacts as structures associated with the Project are developed along Route 63/77. In order to mitigate this issue, the GCEDC and the Town will work together on revised design guidelines for this area to ensure the construction of high quality, attractive buildings along Route 63/77.

The incorporation of the residential properties at the north end of Crosby into the Project make it possible for buildings in TDI to move closer to the Hamlet than was evaluated in the GEIS. In order to mitigate this issue, the GCEDC is proposing new setback of thirty (30) feet from this section of Crosby Road. In addition, in order to ensure that there are no visual impacts that were not addressed in the GEIS/Findings, if and when specific buildings are proposed in locations along the north end of Crosby Road closer to the Hamlet than what was evaluated in the GEIS, subsequent visual impact analysis would have to be completed at that time.

(ii) Demolition of the Houses Along Crosby Road

The demolition of the six residential structures along the north end of Crosby Road and their supporting structures will change the visual character of the area. However, the removal of these structures is considered a minor impact to aesthetics. In addition, these parcels will be incorporated into the Site and the TD Buffer and the Ag/Res Buffer will mitigate the visual impacts from the construction of new structures on these parcels consistent with the visual impact analysis in the GEIS/Findings.

(iii) The Town Water Project

During installation of the water mains and related facilities, large equipment and materials will be located temporarily in proximity to the installation routes. All such impacts are short-term and limited and well within the scope of activities analyzed in the GEIS/Findings.

(iv) STAMP Water & Sewer Service

During installation of the force main and related facilities, large equipment and materials will be located temporarily in proximity to the installation routes. All such impacts are short-term and limited.

b. Noise

(1) The 1366 Facility

Based on operations at 1366 Newton Massachusetts facility and other manufacturing facilities of a similar nature, the types of manufacturing operations that will occur at the 1366 Facility will not generate excessive noise and the 1366 Facility will not generate any noise in excess of the limits set forth in the GEIS/Findings.

(2) The Project Changes

(i) Master Plan Changes/Updates

The changes to the TD zoning boundaries and buffers and the incorporation of the residential properties on the north end of Crosby Road will bring some development closer to the STAMP boundary. However, there will be no changes to the noise limits set for the STAMP boundaries in the GEIS/Findings. Future uses within these areas that were previously undevelopable will have to comply with these noise limits.

(ii) Demolition of the Houses Along Crosby Road

It is anticipated that the demolition of the structures will temporarily generate noise that exceeds background levels. The intermittent noise associated with construction vehicles and equipment will be short-term and temporary in nature. Demolition activities will be limited to daylight working hours, when noise sensitivity is typically lowest. Construction activities will comply with applicable noise ordinances and laws.

(iii) Town Water /STAMP Water & Sewer Service

During installation of the water and sewer mains and related facilities, noise levels will temporarily increase during construction. All such impacts, which will take place during daylight working hours, when noise sensitivity is typically lowest, are well within the scope of construction activities analyzed in the GEIS/Findings.

c. Socioeconomics

(1) The 1366 Facility

Based on the experiences of two similar developments in Oregon and in eastern New York, the STAMP GEIS anticipated that the overall development of the Project would have positive effects on educational levels, per capita personal and household incomes, unemployment, industrial employment and percentage of working age population employed when compared to existing socioeconomic conditions. These effects may spur new or expanded programs of educational, cultural and community service institutions in the region. In addition to employment growth, the 1366 Facility will contribute to the overall population increases in the communities surrounding the Site. This growth is well within the thresholds considered in the GEIS/Findings for the Project. At full build-out and maximum production, the 1366 Facility will employ approximately 1,000 people.

The Town has expressed concern about the impacts of an enhanced payment in lieu of taxes ("**PILOT**") associated with Phase 1 of the 1366 Facility build out. Specifically, Phase 1 of the 1366 Facility will receive a full abatement on all property taxes for a period of 5 years followed by 50% tax equivalent payments in years 6 through 10. In 2012, prior to approving the IZA, the Town completed a fiscal impact analysis in order to better understand the potential fiscal impacts of the Project relative to Town finances. The analysis identifies potential increases associated with Town spending in certain areas including planning and code enforcement, infrastructure, administration, emergency services, highways and courts. However, the analysis

explains that increases in spending will be offset by increased PILOT and tax revenues from the Project. While the analysis was based upon a standard PILOT for 1366 Technologies which provides for a graduated increase to full assessed value over 10 years (20% increase every two years), the enhanced PILOT for Phase 1 of 1366 Technologies' build out will not significantly alter the fiscal impact analysis or the underlying assumptions. This is because the overall impact of the enhanced PILOT will only reduce a portion of PILOT/tax payments from 1366 Technologies to the Town (Phase 1 only). Moreover, the Town is working to establish a fee schedule that will be imposed on all projects to cover the Town's costs from project review through construction. Thus, as noted in the fiscal impact analysis, tax rates in the Town will decrease significantly as revenue from the Project increases over time, particularly as 1366 Technologies proceeds to expand to 1 GW (future phases of 1366 Facility are anticipated to be subject to standard a PILOT).

(2) The Project Changes

(i) Master Plan Changes/Updates

The Master Plan Changes/Updates will have no impact upon socioeconomics.

(ii) Demolition of the Houses Along Crosby Road

The demolition of the six houses along the north end of Crosby Road will remove a limited amount of residential development from the Town. This is a very minor impact to socioeconomics and consistent with impacts analyzed in the GEIS/Findings.

(iii) Town Water /STAMP Water & Sewer Service

The Town Water Project is expected to have a positive socioeconomic benefit upon the Town by dramatically expanding the availability of public water to existing households within the Town. These benefits are consistent with and will build upon the socioeconomic benefits of the Project as a whole.

11. Impacts on Historic and Archaeological Resources

a. The 1366 Facility

Phase 1B studies have been completed on the 1366 Parcels and along any planned access roads and utility support areas for the 1366 Facility. As a result of the Phase 1B work, five archeological sites of potential National Register eligibility, have been identified which could be impacted by the 1366 Facility. Phase II investigations were completed at all five locations. Of these, two identified as requiring further analysis (Archeological Sites 3 and 6). Thus, a Phase III scope of work was proposed and approved by SHPO for both of these sites and was recently completed. No construction activities will take place in the vicinity of Archeological Sites 3 or 6 until the Phase III work is accepted as complete by SHPO.

It is also noted that a Programmatic Agreement between the GCEDC, USACE, and SHPO, initiated by an application for Joint Permit made to USACE, is under development and will stipulate measures to be taken as the Project moves forward to avoid, minimize and/or

mitigate the potential adverse effect on cultural resources consistent with the GEIS/Findings. The 1366 Facility will comply with the stipulations of the Programmatic Agreement to the extent necessary, once it is finalized.

b. The Project Changes

(1) Master Plan Changes/Updates

There are no Master Plan Changes/Updates that will impact historic or archeological resources that will not be addressed through the programmatic agreement.

(2) Demolition of the Houses Along Crosby Road

None of the six houses along the north end of Crosby Road are historic. Moreover, prior to redevelopment of these parcels, the GCEDC will comply with the stipulations of the Programmatic Agreement. To date, Phase 1B field investigations are complete for four of the six parcels. Additional survey work will be undertaken as necessary consistent with the requirements of the Programmatic Agreement once it is finalized.

(3) The Town Water Project

A Phase 1A Cultural Resource investigation was completed for the water route by Deuel Archaeology & CRM in December 2015. It was recommended that a Phase 1B subsurface investigation, in the form of shovel testing be conducted for the archeologically sensitive areas. SHPO indicated in their February 25, 2016 letter, they concur with the Phase 1B testing recommendation and concluded they have no building/structural concerns. A specific scope for the Phase 1B investigation was developed by the GCEDC in consultation with SHPO and Phase 1B work is currently underway. Upon completion of the Phase 1B work, additional survey work will be undertaken as necessary consistent with the requirements of the Programmatic Agreement.

(4) Water Service for STAMP

There are no material impacts to historic or archeological resources associated with water service for STAMP that were not addressed in the GEIS/Findings. Accordingly, the impacts to historic or archeological resources from water service for STAMP are adequately addressed in the GEIS/Findings.

(5) Sewer Service for STAMP

A Phase 1A Cultural Resource investigation was completed for the sewer route by Deuel Archaeology & CRM in December 2015. It was recommended that a Phase 1B subsurface investigation, in the form of shovel testing be conducted for the archeologically sensitive areas. SHPO indicated in their February 25, 2016 letter, they concur with the Phase 1B testing recommendation and concluded they have no building/structural concerns. A specific scope for the Phase 1B investigation has been developed by the GCEDC in consultation with SHPO and the Phase 1B work is currently underway. Upon completion of the Phase 1B work, additional

survey work will be undertaken as necessary consistent with the requirements of the Programmatic Agreement.

12 Impacts on Agricultural Resources

a. The 1366 Facility

The development of the 1366 Facility and related infrastructure improvements will displace active agriculture land on the Site with a modern, high-technology manufacturing facility that will consist of a main building and supporting facilities, such as access drives, parking lots, utilities and landscaping. However, the development of the agricultural lands on the 1366 Parcels was thoroughly analyzed in the GEIS/Findings.

b. The Project Changes

(1) Master Plan Changes/Updates

There are no Master Plan Changes/Updates that will impact agricultural resources. The GEIS assumed all agricultural lands within the Project area would eventually be developed.

(2) Demolition of the Houses Along Crosby Road

There are no material impacts to agricultural resources associated with the demolition of the houses along Crosby Road that were not addressed in the GEIS/Findings.

(3) The Town Water Project

There are no material impacts to agricultural resources associated with the Town Water Project that were not addressed in the GEIS/Findings. In fact, the availability of public water for farming activities may prove to be a benefit to agricultural activities within the Town. In addition, the Project, which included the Town Water Project, has already received approval for STAMP from the NYS Department of Agriculture in January, 2014.

(4) Water Service for STAMP

There are no material impacts to agricultural resources associated with water service for STAMP that were not addressed in the GEIS/Findings.

(5) Sewer Service for STAMP

There are no material impacts to agricultural resources associated with sewer service for STAMP. Accordingly, the impacts to agricultural resources from sewer service for STAMP are adequately addressed in the GEIS/Findings. Nonetheless, GCEDC plans to coordinate with NYS Department of Agriculture to ensure no further agency review is necessary in connection with construction of sewer service for STAMP as this aspect of the Project was unknown at the time that the GCEDC received its certification for the Project.

13. **Short Term Construction Impacts**

a. **The 1366 Facility**

Construction of the 1366 Facility and related infrastructure improvements has the potential to result in air quality impacts that will generally consist of fugitive dust and mobile source emissions from construction vehicles and equipment. In addition, construction activities would involve the use of heavy machinery and vehicles that generally produce noise in excess of background noise levels. However, these activities would occur during daylight hours, when noise sensitivity is lowest. All of the construction related impacts associated with the 1366 Facility are well within the contemplated thresholds analyzed in the GEIS/Findings.

b. **The Project Changes**

(1) **Master Plan Changes/Updates**

There are no short-term construction related impacts associated with the Master Plan Changes/Updates that were not addressed in the GEIS/Findings.

(2) **Demolition of the Houses Along Crosby Road**

As analyzed in the GEIS/Findings, demolition of existing structures will result in short-term impacts to the environment. These impacts may include increased noise and odor, as well as a short-term impact to air associated with structure demolition, soil disturbances and truck movement. Also, during the demolition process, construction personnel are likely to encounter a number of physical hazards that are typically associated with commercial construction. However, as explained in the GEIS/Findings, all construction and demolition will take place within the boundaries of the Site. Thus, the general public's exposure to any Site hazards will be limited. Additionally, the Project will minimize risks to construction personnel by fully complying with applicable OSHA and New York State Labor Law requirements.

(3) **Town Water /STAMP Water & Sewer Service**

During installation of the water and sewer mains and related facilities, air and water quality may be temporarily impacted by construction activities and equipment. Noise levels will also temporarily increase during construction. All such impacts are well within the scope of construction activities analyzed in the GEIS/Findings.

14. **Future Conditions and Thresholds**

a. **The 1366 Facility**

The 1366 Facility and related infrastructure improvements do not exceed any of the conditions and thresholds set forth in the GEIS/Findings. Specifically:

- The 1366 Facility and related infrastructure improvements will not cause an exceedance of the maximum buildable Site area established (618.18 acres);

- The 1366 Facility and related infrastructure improvements will not cause an exceedance of the maximum building square footage;
- The 1366 Facility and related infrastructure improvements will not cause an exceedance of wetland impacts examined in the GEIS/Findings;
- The 1366 Facility and related infrastructure improvements will be constructed in compliance with the zoning regulations established by the STAMP TD;
- The 1366 Facility and related infrastructure improvements will not cause traffic trip generation in exceedance of 70% of projected trips established in the GEIS/Findings; and
- The 1366 Facility and related infrastructure improvements will not cause an exceedance of any utility loads established for the Project in the GEIS/Findings.

b. The Project Changes

(1) Master Plan Changes/Updates

None of the Master Plan Changes/Updates exceed any of the conditions and thresholds set forth in the GEIS/Findings.

(2) Demolition of the Houses Along Crosby Road

The demolition of the houses along Crosby Road will not exceed any of the conditions and thresholds set forth in the GEIS/Findings.

(3) The Town Water Project

The Town Water Project will not exceed any of the conditions and thresholds set forth in the GEIS/Findings.

(4) Water Service for STAMP

The water service for STAMP will not exceed any of the conditions and thresholds set forth in the GEIS/Findings.

(5) Sewer Service for STAMP

The sewer service for STAMP, which will now be provided via a force main to the Medina WWTF rather than via an on-Site WWTP, although a different method that was contemplated in the GEIS/Findings, will not exceed any of the conditions and thresholds set forth in the GEIS/Findings. The threshold for sewer will be reduced from 3.0 MGD to 1.0 MGD, as this is the volume that the Medina WWTF can handle without significant upgrades to its treatment plant.

15. **Incomplete GEIS/Findings Mitigation**

a. Long Term Management Plan

As part of GCEDC's plan for mitigation to avoid and/or minimize any potential impacts to the terrestrial and aquatic ecologies, the GCEDC Findings required the preparation of a LTMP. Town Board Findings required preparation of the LTMP prior to any site plan approvals for use in the review of future Site development. To date, the LTMP has not been finalized, and it is not anticipated that it will be complete prior to initial Site Plan approvals for the Project. In order to ensure that there are no adverse impacts associated with the development of the 1366 Parcels, the GCEDC has proposed deed restrictions and/or conservation easements to further protect wetlands in accordance with the goals of the LTMP. This is being implemented relative to the 1366 Parcels even though the LTMP is still being developed. These restrictions will help to protect wetlands on the Site from being impacted by future development. The GCEDC will also work closely with the Town, and will undertake site plan review for any component of the Project in accordance with the goals set forth by the LTMP.

b. Farmland Protection Plan

The GCEDC Findings and the Town Board Findings require the GCEDC to assist the Town with implementing one or more strategies in the FPSR. To date, a committee has been formed, and is in the early stages of development and exploration of options and programs as outlined in the DGEIS, the FPSR and other sources. The formation of this committee was identified as a protection strategy in the FPSR and thus, the Town has now implemented at least one protection strategy from the FPSR. Nonetheless, the GCEDC will continue to work with the Town to advance farmland protection in the Town.

c. Comprehensive Plan Update

As agreed upon in the IZA, the GCEDC is tasked with assisting the Town with updating its comprehensive plan. To date, the GCEDC has secured a grant on behalf of the Town in order to cover a portion of the cost for the update, which is anticipated to be completed in full in 2016. The need for a comprehensive plan update emerged from the Town's concerns about potential long-term development pressure from STAMP on the rest of the Town. The implementation of the first phase of the 1366 Facility will produce limited development pressure on the Town. Moreover, the Town has imposed a moratorium on the issuance of commercial building permits outside of the Site until the comprehensive plan update is complete. Thus, there will be no adverse impacts from moving forward with initial development at STAMP before the comprehensive plan update has been completed.

d. Design Guidelines

Design standards for buildings to be constructed at STAMP have been discussed between the Town and the GCEDC for several years. In the FGEIS, in response to a comment about design guidelines, the GCEDC noted an intent to form an Architectural Review Committee that would develop design standards for the Site. In the IZA, the Town zoning regulations for the Site provide that any development within any Technology District shall conform to the Town of Alabama's Design Guidelines.

Since the Town adopted its Design Guidelines for STAMP, the GCEDC has formed an Architectural Review Committee comprised of a representative from GCEDC and an architect from GCEDC's engineering firm, Clark Patterson & Lee. A representative from the County Department of Planning also serves on the Committee. In order to help the community understand what specific types of buildings may be constructed at STAMP consistent with the Town's design guidelines, the Committee has developed a series of photographic renderings with explanatory narrative for each of the three TD districts at the Site. In order to ensure that there are no adverse impacts resulting from moving forward with initial development at STAMP prior to development of more specific design guidelines, the Town and the GCEDC have agreed to work closely with 1366 Technologies through the site plan review process to develop a site plan that is consistent with the goals that both the Town and the GCEDC seek to achieve through more specific design guidelines. For the 1366 Facility, particular attention will be paid to building materials visible from public rights of way and landscaping and screening measures.

16. **Unavoidable Adverse Impacts**

a. The 1366 Facility

The development of the 1366 Facility and related infrastructure improvements will result in several unavoidable adverse impacts including short-term unavoidable construction impacts, use of real property, loss of agricultural use on the Site, consumption of energy and the resources that go into making that energy, altered habitats on-Site, and impacts to existing traffic patterns. These impacts are consistent with the analysis of unavoidable adverse impacts in the GEIS/Findings.

b. The Project Changes

(1) Master Plan Changes/Updates

The Master Plan Changes/Updates will not result in any material changes to unavoidable adverse impacts as discussed in the GEIS/Findings.

(2) Demolition of the Houses Along Crosby Road

The demolition of the houses along Crosby Road will result in some unavoidable adverse impacts including short-term unavoidable construction impacts, use of real property and consumption of energy. These impacts are consistent with the analysis of unavoidable adverse impacts in the GEIS/Findings.

(3) The Town Water Project

The installation of the Town Water Project will result in several unavoidable adverse impacts including short-term unavoidable construction impacts, use of real property, impacts to water resources and consumption of energy and the resources that go into making that energy. These impacts are consistent with the analysis of unavoidable adverse impacts in the GEIS/Findings.

(4) **Water Service for STAMP**

The consumption of water supplies for STAMP is consistent with the analysis of unavoidable adverse impacts in the GEIS/Findings.

(5) **Sewer Service for STAMP**

The installation of sewer service for STAMP will result in several unavoidable adverse impacts including short-term unavoidable construction impacts, use of real property, impacts to water resources and consumption of energy and the resources that go into making that energy. These impacts are consistent with the analysis of unavoidable adverse impacts in the GEIS/Findings.

C. **Findings**

A thorough analysis of the environmental impacts of the 1366 Facility and the Project Changes relative to the environmental impacts identified and analyzed in the GEIS/Findings demonstrate that:

1. The impacts associated with the construction and operation of the 1366 Facility and related infrastructure improvements have been adequately analyzed in the GEIS/Findings and will be carried out in conformance with the conditions and thresholds set forth in the GEIS/Findings.
2. The impacts associated with the Master Plan Changes/Updates have been adequately analyzed in the GEIS/Findings and will be carried out in conformance with the conditions and thresholds set forth in the GEIS/Findings.
3. The impacts associated with the Demolition of the houses along Crosby Road have been adequately analyzed in the GEIS/Findings and will be carried out in conformance with the conditions and thresholds set forth in the GEIS/Findings.
4. The impacts associated with the Town Water Project were not analyzed in the GEIS/Findings. However, as detailed in this Amended Findings Statement, there will be no significant adverse environmental impacts associated with the Town Water Project and the Town Water Project will be carried out in conformance with the conditions and thresholds set forth in the GEIS/Findings.
5. The impacts associated with the water service for STAMP have been adequately analyzed in the GEIS/Findings and will be carried out in conformance with the conditions and thresholds set forth in the GEIS/Findings.
6. The impacts associated with the sewer service for STAMP were not analyzed in the GEIS/Findings. However, as detailed in this Amended Findings Statement, there will be no significant adverse environmental impacts associated with providing sewer service for STAMP from the Medina WWTP and Sewer Service for STAMP will be carried out in conformance with the conditions and thresholds set forth in the GEIS/Findings and as modified by this Amended Findings Statement.

7. The impacts associated with the listing of the NLE Bat as a threatened species were not analyzed in the GEIS/Findings. However, as detailed in this Amended Findings Statement, there will be no significant adverse impacts to the NLE Bat as a result of the Project and the listing of the NLE Bat as a Threatened Species under State and Federal law does not exceed any of the conditions and thresholds set forth in the GEIS/Findings.

& Having considered the GCEDC Findings and this Amended Findings Statement for the Western New York Science & Technology Advanced Manufacturing Park (STAMP), and having considered the preceding relevant environmental impacts, facts and conclusions relied upon to meet the requirements of 6 N.Y.C.R.R. § 617.11, and having weighed and balanced the relevant impacts with social, economic and other considerations, this Amended Findings Statement recertifies that:

- (i) The requirements of 6 N.Y.C.R.R. Part 617 have been met; and
- (ii) Consistent with the social, economic and other essential considerations from among the reasonable alternatives available, the action remains one which avoids or minimizes adverse environmental effects to the maximum extent practicable, and that adverse environmental impacts will be avoided or minimized to the maximum extent practicable by incorporating as conditions to the decision those mitigative measures which were identified as practicable.

Genesee County Economic Development Center

Name of Agency

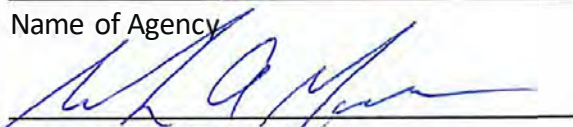
Signature of Responsible Official

Mark A. Masse, CPA

Name of Responsible Official

Senior Vice President of Operations

Title of Responsible Official

July 14, 2016

Date

99 MedTech Drive, Suite 106, Batavia, New York 14020

Address of Agency

lead Agency Contact:

Mark A. Masse, CPA

Senior Vice President of Operations

Genesee County Economic Development Center

99 MedTech Drive

Suite 106

Batavia, NY 14020

Phone: (585) 343-4866, ext. 17

Fax: (585) 343-0848

Email: mmasse@gcedc.com

**Full Environmental Assessment Form
Part 1 - Project and Setting**

Instructions for Completing Part 1

Part 1 is to be completed by the applicant or project sponsor. Responses become part of the application for approval or funding, are subject to public review, and may be subject to further verification.

Complete Part 1 based on information currently available. If additional research or investigation would be needed to fully respond to any item, please answer as thoroughly as possible based on current information; indicate whether missing information does not exist, or is not reasonably available to the sponsor; and, when possible, generally describe work or studies which would be necessary to update or fully develop that information.

Applicants/sponsors must complete all items in Sections A & B. In Sections C, D & E, most items contain an initial question that must be answered either "Yes" or "No". If the answer to the initial question is "Yes", complete the sub-questions that follow. If the answer to the initial question is "No", proceed to the next question. Section F allows the project sponsor to identify and attach any additional information. Section G requires the name and signature of the applicant or project sponsor to verify that the information contained in Part 1 is accurate and complete.

A. Project and Applicant/Sponsor Information.

Name of Action or Project: Gateway Project		
Project Location (describe, and attach a general location map): 6840 Crosby Road, Alabama, NY 14013		
Brief Description of Proposed Action (include purpose or need): This project will be an 80 ton-per-day green hydrogen production facility, built in two 40 ton-per-day phases. The hydrogen is produced by electrolysis using clean hydropower. The process produces no pollution and creates essentially no waste. The facility will include an approximately 42,000 sq-ft building housing the hydrogen production equipment, a small control building and an approximately 10,000 sq-ft building housing office space, a conference room, facility restrooms, employee breakroom and maintenance shop. Additional equipment located outside includes cooling units, electrical transformers & cabinets, an electrical substation, tanks, pumps, compressors, liquefaction cold-boxes and a filling facility for transport tankers that pick up the liquid hydrogen product for delivery. There will be a small employee 20-space parking lot, a truck trailer parking area with space for 5 to 10 40' trailers. Roadways and parking lots will use an impervious surface such as concrete or asphalt, equipment and tanks will be on concrete pads all other areas wherever possible will retain a permeable cover such as grass or gravel. A small retention pond will be constructed to hold stormwater run-off. Phase 2 starts after phase 1 commissioning.		
Name of Applicant/Sponsor: Gateway Project		Telephone:
		E-Mail:
Address: 6840 Crosby Road		
City/PO: Alabama	State: NY	Zip Code: 14013
Project Contact (if not same as sponsor; give name and title/role): Brenor Brophy, Vice President Project Development		Telephone: (408) 823-6566
		E-Mail: brbrophy@plugpower.com
Address: 968 Albany Shaker Road		
City/PO: Latham	State: NY	Zip Code: 12110
Property Owner (if not same as sponsor):		Telephone:
		E-Mail:
Address:		
City/PO:	State:	Zip Code:

B. Government Approvals

B. Government Approvals, Funding, or Sponsorship. ("Funding" includes grants, loans, tax relief, and any other forms of financial assistance.)		
Government Entity	If Yes: Identify Agency and Approval(s) Required	Application Date (Actual or projected)
a. City Counsel, Town Board, <input type="checkbox"/> Yes <input checked="" type="checkbox"/> No or Village Board of Trustees		
b. City, Town or Village Planning Board or Commission <input checked="" type="checkbox"/> Yes <input type="checkbox"/> No	Town of Alabama Planning Board	
c. City, Town or Village Zoning Board of Appeals <input type="checkbox"/> Yes <input checked="" type="checkbox"/> No		
d. Other local agencies <input type="checkbox"/> Yes <input type="checkbox"/> No		
e. County agencies <input checked="" type="checkbox"/> Yes <input type="checkbox"/> No	Genesee County Dept. of Health Genesee County Planning Board	
f. Regional agencies <input type="checkbox"/> Yes <input type="checkbox"/> No		
g. State agencies <input checked="" type="checkbox"/> Yes <input type="checkbox"/> No	NYSDEC, SWPPP, NYPA	
h. Federal agencies <input type="checkbox"/> Yes <input type="checkbox"/> No		
i. Coastal Resources.		
i. Is the project site within a Coastal Area, or the waterfront area of a Designated Inland Waterway?		<input type="checkbox"/> Yes <input checked="" type="checkbox"/> No
ii. Is the project site located in a community with an approved Local Waterfront Revitalization Program?		<input type="checkbox"/> Yes <input checked="" type="checkbox"/> No
iii. Is the project site within a Coastal Erosion Hazard Area?		<input type="checkbox"/> Yes <input checked="" type="checkbox"/> No

C. Planning and Zoning

C.1. Planning and zoning actions.	
Will administrative or legislative adoption, or amendment of a plan, local law, ordinance, rule or regulation be the only approval(s) which must be granted to enable the proposed action to proceed?	<input type="checkbox"/> Yes <input checked="" type="checkbox"/> No
<ul style="list-style-type: none"> • If Yes, complete sections C, F and G. • If No, proceed to question C.2 and complete all remaining sections and questions in Part 1 	
C.2. Adopted land use plans.	
a. Do any municipally- adopted (city, town, village or county) comprehensive land use plan(s) include the site where the proposed action would be located?	<input checked="" type="checkbox"/> Yes <input type="checkbox"/> No
If Yes, does the comprehensive plan include specific recommendations for the site where the proposed action would be located?	<input checked="" type="checkbox"/> Yes <input type="checkbox"/> No
b. Is the site of the proposed action within any local or regional special planning district (for example: Greenway; Brownfield Opportunity Area (BOA); designated State or Federal heritage area; watershed management plan; or other?)	<input type="checkbox"/> Yes <input checked="" type="checkbox"/> No
If Yes, identify the plan(s):	

c. Is the proposed action located wholly or partially within an area listed in an adopted municipal open space plan, or an adopted municipal farmland protection plan?	<input checked="" type="checkbox"/> Yes <input type="checkbox"/> No
If Yes, identify the plan(s):	
Genesee County	

C.3. Zoning

a. Is the site of the proposed action located in a municipality with an adopted zoning law or ordinance. Yes No
 If Yes, what is the zoning classification(s) including any applicable overlay district?
Technology District 1

b. Is the use permitted or allowed by a special or conditional use permit? Yes No

c. Is a zoning change requested as part of the proposed action? Yes No
 If Yes,
 i. What is the proposed new zoning for the site? _____

C.4. Existing community services.

a. In what school district is the project site located? Oakfield - Alabama

b. What police or other public protection forces serve the project site?
Genesee County Sheriff

c. Which fire protection and emergency medical services serve the project site?
Alabama Fire Dept., Genesee County EMS, Mercyflight Ambulance

d. What parks serve the project site?
N/A

D. Project Details

D.1. Proposed and Potential Development

a. What is the general nature of the proposed action (e.g., residential, industrial, commercial, recreational; if mixed, include all components)? Industrial

b. a. Total acreage of the site of the proposed action? 53.9 acres
 b. Total acreage to be physically disturbed? 24.9 acres
 c. Total acreage (project site and any contiguous properties) owned or controlled by the applicant or project sponsor? 53.9 acres

c. Is the proposed action an expansion of an existing project or use? Yes No
 i. If Yes, what is the approximate percentage of the proposed expansion and identify the units (e.g., acres, miles, housing units, square feet)? % _____ Units: _____

d. Is the proposed action a subdivision, or does it include a subdivision? Yes No
 If Yes,
 i. Purpose or type of subdivision? (e.g., residential, industrial, commercial; if mixed, specify types)
Industrial
 ii. Is a cluster/conservation layout proposed? Yes No
 iii. Number of lots proposed? 1
 iv. Minimum and maximum proposed lot sizes? Minimum 53.9 ac Maximum N/A

e. Will the proposed action be constructed in multiple phases? Yes No
 i. If No, anticipated period of construction: _____ months
 ii. If Yes:
 • Total number of phases anticipated 2
 • Anticipated commencement date of phase 1 (including demolition) 3 month 2022 year
 • Anticipated completion date of final phase 6 month 2023 year
 • Generally describe connections or relationships among phases, including any contingencies where progress of one phase may determine timing or duration of future phases: Phase 2 will follow on substation and distribution line built for phase 1. We will complete phase 1 and bring online before commencing construction on phase 2.

f. Does the project include new residential uses? Yes No
 If Yes, show numbers of units proposed.

	One Family	Two Family	Three Family	Multiple Family (four or more)
Initial Phase	_____	_____	_____	_____
At completion	_____	_____	_____	_____
of all phases	_____	_____	_____	_____

g. Does the proposed action include new non-residential construction (including expansions)? Yes No
 If Yes,

i. Total number of structures 3

ii. Dimensions (in feet) of largest proposed structure: 30' height; 100' width; and 700' length

iii. Approximate extent of building space to be heated or cooled: 42,000 square feet

h. Does the proposed action include construction or other activities that will result in the impoundment of any liquids, such as creation of a water supply, reservoir, pond, lake, waste lagoon or other storage? Yes No
 If Yes,

i. Purpose of the impoundment: Stormwater Pond

ii. If a water impoundment, the principal source of the water: Ground water Surface water streams Other specify: Stormwater

iii. If other than water, identify the type of impounded/contained liquids and their source. N/A

iv. Approximate size of the proposed impoundment. Volume: _____ million gallons; surface area: 2 acres

v. Dimensions of the proposed dam or impounding structure: 8 height; 100 length

vi. Construction method/materials for the proposed dam or impounding structure (e.g., earth fill, rock, wood, concrete): Earthfill

D.2. Project Operations

a. Does the proposed action include any excavation, mining, or dredging, during construction, operations, or both? (Not including general site preparation, grading or installation of utilities or foundations where all excavated materials will remain onsite) Yes No
 If Yes:

i. What is the purpose of the excavation or dredging? _____

ii. How much material (including rock, earth, sediments, etc.) is proposed to be removed from the site?

- Volume (specify tons or cubic yards): _____
- Over what duration of time? _____

iii. Describe nature and characteristics of materials to be excavated or dredged, and plans to use, manage or dispose of them.

iv. Will there be onsite dewatering or processing of excavated materials? Yes No
 If yes, describe. _____

v. What is the total area to be dredged or excavated? _____ acres

vi. What is the maximum area to be worked at any one time? _____ acres

vii. What would be the maximum depth of excavation or dredging? _____ feet

viii. Will the excavation require blasting? Yes No

ix. Summarize site reclamation goals and plan: _____

b. Would the proposed action cause or result in alteration of, increase or decrease in size of, or encroachment into any existing wetland, waterbody, shoreline, beach or adjacent area? Yes No
 If Yes:

i. Identify the wetland or waterbody which would be affected (by name, water index number, wetland map number or geographic description): _____

ii. Describe how the proposed action would affect that waterbody or wetland, e.g. excavation, fill, placement of structures, or alteration of channels, banks and shorelines. Indicate extent of activities, alterations and additions in square feet or acres:

iii. Will the proposed action cause or result in disturbance to bottom sediments? Yes No

If Yes, describe: _____

iv. Will the proposed action cause or result in the destruction or removal of aquatic vegetation? Yes No

If Yes:

- acres of aquatic vegetation proposed to be removed: _____
- expected acreage of aquatic vegetation remaining after project completion: _____
- purpose of proposed removal (e.g. beach clearing, invasive species control, boat access): _____
- proposed method of plant removal: _____
- if chemical/herbicide treatment will be used, specify product(s): _____

v. Describe any proposed reclamation/mitigation following disturbance: _____

c. Will the proposed action use, or create a new demand for water? Yes No

If Yes:

i. Total anticipated water usage/demand per day: 280,000 gallons/day

ii. Will the proposed action obtain water from an existing public water supply? Yes No

If Yes:

- Name of district or service area: STAMP Site via agreement with Genesee County
- Does the existing public water supply have capacity to serve the proposal? Yes No
- Is the project site in the existing district? Yes No
- Is expansion of the district needed? Yes No
- Do existing lines serve the project site? Yes No

iii. Will line extension within an existing district be necessary to supply the project? Yes No

If Yes:

- Describe extensions or capacity expansions proposed to serve this project: New Pembroke water line under construction will provide additional capacity; New water line from STAMP entrance to site to be constructed.
- Source(s) of supply for the district: Genesee County

iv. Is a new water supply district or service area proposed to be formed to serve the project site? Yes No

If Yes:

- Applicant/sponsor for new district: _____
- Date application submitted or anticipated: _____
- Proposed source(s) of supply for new district: _____

v. If a public water supply will not be used, describe plans to provide water supply for the project: _____

vi. If water supply will be from wells (public or private), what is the maximum pumping capacity: _____ gallons/minute.

d. Will the proposed action generate liquid wastes? Yes No

If Yes:

i. Total anticipated liquid waste generation per day: 70,500 gallons/day

ii. Nature of liquid wastes to be generated (e.g., sanitary wastewater, industrial; if combination, describe all components and approximate volumes or proportions of each): Sanitary wastewater 500 GPD; Reject water from RO system @25% rejection <=70,000 GPD, amount is seasonal as we will use some reject water for cooling in summer.

iii. Will the proposed action use any existing public wastewater treatment facilities? Yes No

If Yes:

- Name of wastewater treatment plant to be used: _____
- Name of district: _____
- Does the existing wastewater treatment plant have capacity to serve the project? Yes No
- Is the project site in the existing district? Yes No
- Is expansion of the district needed? Yes No

• Do existing sewer lines serve the project site? Yes No
 • Will a line extension within an existing district be necessary to serve the project? Yes No
 If Yes:
 • Describe extensions or capacity expansions proposed to serve this project: _____

iv. Will a new wastewater (sewage) treatment district be formed to serve the project site? Yes No
 If Yes:
 • Applicant/sponsor for new district: _____
 • Date application submitted or anticipated: _____
 • What is the receiving water for the wastewater discharge? _____

v. If public facilities will not be used, describe plans to provide wastewater treatment for the project, including specifying proposed receiving water (name and classification if surface discharge or describe subsurface disposal plans):
STAMP has application pending w/ NYSDEC for new WWTF at STAMP site

vi. Describe any plans or designs to capture, recycle or reuse liquid waste: _____

e. Will the proposed action disturb more than one acre and create stormwater runoff, either from new point sources (i.e. ditches, pipes, swales, curbs, gutters or other concentrated flows of stormwater) or non-point source (i.e. sheet flow) during construction or post construction? Yes No
 If Yes:
 i. How much impervious surface will the project create in relation to total size of project parcel?
 _____ Square feet or 2 acres (impervious surface)
 _____ Square feet or 53.9 acres (parcel size)
 ii. Describe types of new point sources. Parking lots, internal roadways, concrete pads for equipment

 iii. Where will the stormwater runoff be directed (i.e. on-site stormwater management facility/structures, adjacent properties, groundwater, on-site surface water or off-site surface waters)?
Onsite stormwater management facility

 • If to surface waters, identify receiving water bodies or wetlands: _____

 • Will stormwater runoff flow to adjacent properties? Yes No

iv. Does the proposed plan minimize impervious surfaces, use pervious materials or collect and re-use stormwater? Yes No

f. Does the proposed action include, or will it use on-site, one or more sources of air emissions, including fuel combustion, waste incineration, or other processes or operations? Yes No
 If Yes, identify:
 i. Mobile sources during project operations (e.g., heavy equipment, fleet or delivery vehicles)
Trucks
 ii. Stationary sources during construction (e.g., power generation, structural heating, batch plant, crushers)
None
 iii. Stationary sources during operations (e.g., process emissions, large boilers, electric generation)
None

g. Will any air emission sources named in D.2.f (above), require a NY State Air Registration, Air Facility Permit, or Federal Clean Air Act Title IV or Title V Permit? Yes No
 If Yes:
 i. Is the project site located in an Air quality non-attainment area? (Area routinely or periodically fails to meet ambient air quality standards for all or some parts of the year) Yes No
 ii. In addition to emissions as calculated in the application, the project will generate:
 • _____ Tons/year (short tons) of Carbon Dioxide (CO₂)
 • _____ Tons/year (short tons) of Nitrous Oxide (N₂O)
 • _____ Tons/year (short tons) of Perfluorocarbons (PFCs)
 • _____ Tons/year (short tons) of Sulfur Hexafluoride (SF₆)
 • _____ Tons/year (short tons) of Carbon Dioxide equivalent of Hydrofluorocarbons (HFCs)
 • _____ Tons/year (short tons) of Hazardous Air Pollutants (HAPs)

h. Will the proposed action generate or emit methane (including, but not limited to, sewage treatment plants, landfills, composting facilities)? Yes No

If Yes:

i. Estimate methane generation in tons/year (metric): _____

ii. Describe any methane capture, control or elimination measures included in project design (e.g., combustion to generate heat or electricity, flaring): _____

i. Will the proposed action result in the release of air pollutants from open-air operations or processes, such as quarry or landfill operations? Yes No

If Yes: Describe operations and nature of emissions (e.g., diesel exhaust, rock particulates/dust): _____

j. Will the proposed action result in a substantial increase in traffic above present levels or generate substantial new demand for transportation facilities or services? Yes No

If Yes:

i. When is the peak traffic expected (Check all that apply): Morning Evening Weekend
 Randomly between hours of _____ to _____.

ii. For commercial activities only, projected number of truck trips/day and type (e.g., semi trailers and dump trucks): _____
Tanker trucks - 16 per day

iii. Parking spaces: Existing 0 Proposed 20 Net increase/decrease 20

iv. Does the proposed action include any shared use parking? Yes No

v. If the proposed action includes any modification of existing roads, creation of new roads or change in existing access, describe:
Reconstruction of Crosby Road, new access road to facility.

vi. Are public/private transportation service(s) or facilities available within 1/2 mile of the proposed site? Yes No

vii. Will the proposed action include access to public transportation or accommodations for use of hybrid, electric or other alternative fueled vehicles? Yes No

viii. Will the proposed action include plans for pedestrian or bicycle accommodations for connections to existing pedestrian or bicycle routes? Yes No

k. Will the proposed action (for commercial or industrial projects only) generate new or additional demand for energy? Yes No

If Yes:

i. Estimate annual electricity demand during operation of the proposed action: 112MW phase 1; 225MW phase 2

ii. Anticipated sources/suppliers of electricity for the project (e.g., on-site combustion, on-site renewable, via grid/local utility, or other):
Grid - Hydropower

iii. Will the proposed action require a new, or an upgrade, to an existing substation? Yes No
New STAMP substation to be constructed

l. Hours of operation. Answer all items which apply.

<p>i. During Construction:</p> <ul style="list-style-type: none"> • Monday - Friday: <u>7am to 5pm</u> • Saturday: <u>None</u> • Sunday: <u>None</u> • Holidays: <u>None</u> 	<p>ii. During Operations:</p> <ul style="list-style-type: none"> • Monday - Friday: <u>24 Hours</u> • Saturday: <u>24 Hours</u> • Sunday: <u>24 Hours</u> • Holidays: <u>24 Hours</u>
--	---

m. Will the proposed action produce noise that will exceed existing ambient noise levels during construction, operation, or both? Yes No

If yes:

i. Provide details including sources, time of day and duration:

During construction, just construction noise sources such as trucks and excavators

In operation, 12 compressors: 90dB at compressor, 25.4dB at STAMP boundary (1700' at closest)

ii. Will the proposed action remove existing natural barriers that could act as a noise barrier or screen? Yes No

Describe: _____

n. Will the proposed action have outdoor lighting? Yes No

If yes:

i. Describe source(s), location(s), height of fixture(s), direction/aim, and proximity to nearest occupied structures:

Perimeter lighting on 10-20' poles, lighting on equipment skids and at building exits. Lighting in parking area. Downward-facing high-efficiency LED lights, dark-sky compliant.

ii. Will proposed action remove existing natural barriers that could act as a light barrier or screen? Yes No

Describe: _____

o. Does the proposed action have the potential to produce odors for more than one hour per day? Yes No

If Yes, describe possible sources, potential frequency and duration of odor emissions, and proximity to nearest occupied structures: _____

p. Will the proposed action include any bulk storage of petroleum (combined capacity of over 1,100 gallons) or chemical products 185 gallons in above ground storage or any amount in underground storage? Yes No

If Yes:

i. Product(s) to be stored _____

ii. Volume(s) _____ per unit time _____ (e.g., month, year)

iii. Generally, describe the proposed storage facilities: _____

q. Will the proposed action (commercial, industrial and recreational projects only) use pesticides (i.e., herbicides, insecticides) during construction or operation? Yes No

If Yes:

i. Describe proposed treatment(s): _____

ii. Will the proposed action use Integrated Pest Management Practices? Yes No

r. Will the proposed action (commercial or industrial projects only) involve or require the management or disposal of solid waste (excluding hazardous materials)? Yes No

If Yes:

i. Describe any solid waste(s) to be generated during construction or operation of the facility:

• Construction: 1 tons per month (unit of time)

• Operation: 0.25 tons per Year (unit of time)

ii. Describe any proposals for on-site minimization, recycling or reuse of materials to avoid disposal as solid waste:

• Construction: _____

• Operation: _____

iii. Proposed disposal methods/facilities for solid waste generated on-site:

• Construction: Dumpster

• Operation: Typical Commercial Trash Receptical

s. Does the proposed action include construction or modification of a solid waste management facility? Yes No

If Yes:

- i. Type of management or handling of waste proposed for the site (e.g., recycling or transfer station, composting, landfill, or other disposal activities): _____
- ii. Anticipated rate of disposal/processing:
 - _____ Tons/month, if transfer or other non-combustion/thermal treatment, or
 - _____ Tons/hour, if combustion or thermal treatment
- iii. If landfill, anticipated site life: _____ years

t. Will the proposed action at the site involve the commercial generation, treatment, storage, or disposal of hazardous waste? Yes No

If Yes:

- i. Name(s) of all hazardous wastes or constituents to be generated, handled or managed at facility: _____
- ii. Generally describe processes or activities involving hazardous wastes or constituents: _____
- iii. Specify amount to be handled or generated _____ tons/month
- iv. Describe any proposals for on-site minimization, recycling or reuse of hazardous constituents: _____
- v. Will any hazardous wastes be disposed at an existing offsite hazardous waste facility? Yes No

If Yes: provide name and location of facility: _____

If No: describe proposed management of any hazardous wastes which will not be sent to a hazardous waste facility: _____

E. Site and Setting of Proposed Action

E.1. Land uses on and surrounding the project site

a. Existing land uses.

i. Check all uses that occur on, adjoining and near the project site.

- Urban Industrial Commercial Residential (suburban) Rural (non-farm)
- Forest Agriculture Aquatic Other (specify): _____

ii. If mix of uses, generally describe: _____

b. Land uses and covertypes on the project site.

Land use or Covertype	Current Acreage	Acreage After Project Completion	Change (Acres +/-)
• Roads, buildings, and other paved or impervious surfaces	+/- 0.25	+/- 2.25	+ 2.0
• Forested	+/- 10.0	+/- 10.0	0.0
• Meadows, grasslands or brushlands (non-agricultural, including abandoned agricultural)	41.95	37.95	-4.0
• Agricultural (includes active orchards, field, greenhouse etc.)	0	0	0
• Surface water features (lakes, ponds, streams, rivers, etc.)	0	+/- 2.0	+2.0
• Wetlands (freshwater or tidal)	+/- 1.7	+/- 1.7	0.0
• Non-vegetated (bare rock, earth or fill)	0	0	0
• Other Describe: _____			

c. Is the project site presently used by members of the community for public recreation? Yes No
i. If Yes: explain: _____

d. Are there any facilities serving children, the elderly, people with disabilities (e.g., schools, hospitals, licensed day care centers, or group homes) within 1500 feet of the project site? Yes No
If Yes,
i. Identify Facilities: _____

e. Does the project site contain an existing dam? Yes No
If Yes:
i. Dimensions of the dam and impoundment:
• Dam height: _____ feet
• Dam length: _____ feet
• Surface area: _____ acres
• Volume impounded: _____ gallons OR acre-feet
ii. Dam's existing hazard classification: _____
iii. Provide date and summarize results of last inspection: _____

f. Has the project site ever been used as a municipal, commercial or industrial solid waste management facility, or does the project site adjoin property which is now, or was at one time, used as a solid waste management facility? Yes No
If Yes:
i. Has the facility been formally closed? Yes No
• If yes, cite sources/documentation: _____
ii. Describe the location of the project site relative to the boundaries of the solid waste management facility: _____

iii. Describe any development constraints due to the prior solid waste activities: _____

g. Have hazardous wastes been generated, treated and/or disposed of at the site, or does the project site adjoin property which is now or was at one time used to commercially treat, store and/or dispose of hazardous waste? Yes No
If Yes:
i. Describe waste(s) handled and waste management activities, including approximate time when activities occurred: _____

h. Potential contamination history. Has there been a reported spill at the proposed project site, or have any remedial actions been conducted at or adjacent to the proposed site? Yes No
If Yes:
i. Is any portion of the site listed on the NYSDEC Spills Incidents database or Environmental Site Remediation database? Check all that apply: Yes No
 Yes – Spills Incidents database Provide DEC ID number(s): 15105158
 Yes – Environmental Site Remediation database Provide DEC ID number(s): _____
 Neither database
ii. If site has been subject of RCRA corrective activities, describe control measures: N/A

iii. Is the project within 2000 feet of any site in the NYSDEC Environmental Site Remediation database? Yes No
If yes, provide DEC ID number(s): _____
iv. If yes to (i), (ii) or (iii) above, describe current status of site(s):
Record Closed

v. Is the project site subject to an institutional control limiting property uses? Yes No

- If yes, DEC site ID number: _____
- Describe the type of institutional control (e.g., deed restriction or easement): _____
- Describe any use limitations: _____
- Describe any engineering controls: _____
- Will the project affect the institutional or engineering controls in place? Yes No
- Explain: _____

E.2. Natural Resources On or Near Project Site

a. What is the average depth to bedrock on the project site? >6.5 feet

b. Are there bedrock outcroppings on the project site? Yes No
 If Yes, what proportion of the site is comprised of bedrock outcroppings? _____ %

c. Predominant soil type(s) present on project site:	<u>Odessa Silt Loam</u>	<u>63</u> %
	<u>Lakemont Silty Clay</u>	<u>14</u> %
	<u>Collomer Silt Loam</u>	<u>12</u> %

d. What is the average depth to the water table on the project site? Average: _____ feet

e. Drainage status of project site soils: Well Drained: 0 % of site
 Moderately Well Drained: 12 % of site
 Poorly Drained: 88 % of site

f. Approximate proportion of proposed action site with slopes: 0-10%: 100 % of site
 10-15%: 0 % of site
 15% or greater: 0 % of site

g. Are there any unique geologic features on the project site? Yes No
 If Yes, describe: _____

h. Surface water features.

i. Does any portion of the project site contain wetlands or other waterbodies (including streams, rivers, ponds or lakes)? Yes No

ii. Do any wetlands or other waterbodies adjoin the project site? Yes No

If Yes to either *i* or *ii*, continue. If No, skip to E.2.i.

iii. Are any of the wetlands or waterbodies within or adjoining the project site regulated by any federal, state or local agency? Yes No

iv. For each identified regulated wetland and waterbody on the project site, provide the following information:

- Streams: Name 837-78, 847-687 Classification C
- Lakes or Ponds: Name _____ Classification _____
- Wetlands: Name Federal Waters Approximate Size _____
- Wetland No. (if regulated by DEC) _____

v. Are any of the above water bodies listed in the most recent compilation of NYS water quality-impaired waterbodies? Yes No

If yes, name of impaired water body/bodies and basis for listing as impaired: N/A

i. Is the project site in a designated Floodway? Yes No

j. Is the project site in the 100-year Floodplain? Yes No

k. Is the project site in the 500-year Floodplain? Yes No

l. Is the project site located over, or immediately adjoining, a primary, principal or sole source aquifer? Yes No

If Yes:
 i. Name of aquifer: _____

m. Identify the predominant wildlife species that occupy or use the project site: <u>Whitetailed Deer</u> <u>Squirrels and other mammals</u> <u>Common song birds</u>	_____ _____ _____
n. Does the project site contain a designated significant natural community? <input type="checkbox"/> Yes <input checked="" type="checkbox"/> No If Yes:	
i. Describe the habitat/community (composition, function, and basis for designation): _____ _____	
ii. Source(s) of description or evaluation: _____	
iii. Extent of community/habitat:	
<ul style="list-style-type: none"> • Currently: _____ acres • Following completion of project as proposed: _____ acres • Gain or loss (indicate + or -): _____ acres 	
o. Does project site contain any species of plant or animal that is listed by the federal government or NYS as endangered or threatened, or does it contain any areas identified as habitat for an endangered or threatened species? <input type="checkbox"/> Yes <input checked="" type="checkbox"/> No If Yes:	
i. Species and listing (endangered or threatened): _____ _____	
p. Does the project site contain any species of plant or animal that is listed by NYS as rare, or as a species of special concern? <input type="checkbox"/> Yes <input checked="" type="checkbox"/> No If Yes:	
i. Species and listing: _____ _____	
q. Is the project site or adjoining area currently used for hunting, trapping, fishing or shell fishing? <input type="checkbox"/> Yes <input checked="" type="checkbox"/> No If yes, give a brief description of how the proposed action may affect that use: _____ _____	
E.3. Designated Public Resources On or Near Project Site	
a. Is the project site, or any portion of it, located in a designated agricultural district certified pursuant to Agriculture and Markets Law, Article 25-AA, Section 303 and 304? <input type="checkbox"/> Yes <input checked="" type="checkbox"/> No If Yes, provide county plus district name/number: _____	
b. Are agricultural lands consisting of highly productive soils present? <input type="checkbox"/> Yes <input checked="" type="checkbox"/> No i. If Yes: acreage(s) on project site? _____ ii. Source(s) of soil rating(s): _____	
c. Does the project site contain all or part of, or is it substantially contiguous to, a registered National Natural Landmark? <input type="checkbox"/> Yes <input checked="" type="checkbox"/> No If Yes:	
i. Nature of the natural landmark: <input type="checkbox"/> Biological Community <input type="checkbox"/> Geological Feature ii. Provide brief description of landmark, including values behind designation and approximate size/extent: _____ _____	
d. Is the project site located in or does it adjoin a state listed Critical Environmental Area? <input type="checkbox"/> Yes <input checked="" type="checkbox"/> No If Yes:	
i. CEA name: _____ ii. Basis for designation: _____ iii. Designating agency and date: _____	

e. Does the project site contain, or is it substantially contiguous to, a building, archaeological site, or district which is listed on the National or State Register of Historic Places, or that has been determined by the Commissioner of the NYS Office of Parks, Recreation and Historic Preservation to be eligible for listing on the State Register of Historic Places? Yes No

If Yes:

i. Nature of historic/archaeological resource: Archaeological Site Historic Building or District

ii. Name: _____

iii. Brief description of attributes on which listing is based: _____

f. Is the project site, or any portion of it, located in or adjacent to an area designated as sensitive for archaeological sites on the NY State Historic Preservation Office (SHPO) archaeological site inventory? Yes No

g. Have additional archaeological or historic site(s) or resources been identified on the project site? Yes No

If Yes:

i. Describe possible resource(s): Phase 1-3 have been completed on site and site has been cleared by SHPO

ii. Basis for identification: _____

h. Is the project site within five miles of any officially designated and publicly accessible federal, state, or local scenic or aesthetic resource? Yes No

If Yes:

i. Identify resource: _____

ii. Nature of, or basis for, designation (e.g., established highway overlook, state or local park, state historic trail or scenic byway, etc.): _____

iii. Distance between project and resource: _____ miles.

i. Is the project site located within a designated river corridor under the Wild, Scenic and Recreational Rivers Program 6 NYCRR 666? Yes No

If Yes:

i. Identify the name of the river and its designation: _____

ii. Is the activity consistent with development restrictions contained in 6NYCRR Part 666? Yes No

F. Additional Information

Attach any additional information which may be needed to clarify your project.

If you have identified any adverse impacts which could be associated with your proposal, please describe those impacts plus any measures which you propose to avoid or minimize them.

G. Verification

I certify that the information provided is true to the best of my knowledge.

Applicant/Sponsor Name Brenor Brophy Date December 30, 2020

Signature  Title Vice President Project Development



**GCEDC Board Meeting
Thursday, February 4, 2021
Location: Electronically
4:00 PM**

GCEDC MINUTES

Attendance

Board Members: C. Yunker, T. Bender, C. Klotzbach, P. Battaglia, P. Zeliff, A. Vanderhoof, M. Gray
Staff: L. Farrell, M. Masse, L. Casey, J. Krencik, S. Hyde, C. Suozzi, P. Kennett
Guests: D. Cunningham (GGLDC Board Member), S. Noble-Moag (GGLDC Board Member), M. Wiater (GGLDC Board Member), G. Torrey (GGLDC Board Member), R. Gaenzle (Harris Beach), P. Williams (LandPro Equipment), D. Cierzynski (Cierzynski Consulting, LLC), M. Landers (County Manager)
Absent:

1.0 Call to Order

P. Zeliff called the meeting to order at 4:03 p.m. via conference call / video conference.

Because of the Novel Coronavirus (COVID-19) Emergency and State and Federal bans on large meetings or gatherings and pursuant to Governor Cuomo’s Executive Order 202.1 issued on March 12, 2020 suspending the Open Meetings Law, this Meeting is being held electronically via conference call / video conference instead of a public meeting open for the public to attend in person.

Presentation – D. Cierzynski and P. Williams provided an overview of the LandPro Equipment, LLC project. LandPro Equipment, LLC will acquire and develop a 14-acre parcel in the Town of Batavia to construct a 50,000 square-foot facility for a full-service John Deere Agriculture and Turf Dealership. Ninety-five percent of the facility will be used for parts, service, and training, with 5% used for retail.

D. Cierzynski and P. Williams left the meeting at 4:13.

1.1 Enter Executive Session

C. Yunker made a motion to enter executive session under the Public Officers Law, Article 7, Open Meetings Law Section 105, at 4:14 p.m. for the following reasons:

1. The medical, financial, credit or employment history of a particular person or corporation, or matters leading to the appointment, employment, promotion, demotion, discipline, suspension, dismissal or removal of a particular person or corporation.

The motion was seconded by T. Bender and approved by all members present.

1.2 Enter Public Session

C. Klotzbach made a motion to enter back into public session at 4:55 p.m., seconded by P. Battaglia and approved by all members present.

2.0 Chairman's Report & Activities

2.1 Upcoming Meetings:

Next Scheduled Board Meeting: Thursday, March 4th at 4:00 p.m.

Audit & Finance Committee Meeting: Tuesday, March 2nd at 8:30 a.m.

STAMP Committee Meeting: : Tuesday, March 2nd at 10:30 a.m.

Governance & Nominating Committee Meeting: Thursday, March 4th at 3:00 p.m.

CANCELLED: Annual Meeting: Friday, March 5th at 12:00 p.m.

2.2 Agenda Additions / Deletions / Other Business-

M. Gray made a motion to table agenda item 4.4 Cyber Insurance; the motion was seconded by A. Vanderhoof. Roll call resulted as follows:

P. Battaglia -	Yes	C. Yunker -	Yes
T. Bender -	Yes	P. Zeff -	Yes
C. Klotzbach -	Yes	M. Gray -	Yes
A. Vanderhoof -	Yes		

The item was approved as presented.

2.3 Minutes: January 7, 2021

M. Gray made a motion to approve the January 7, 2021 minutes as presented; the motion was seconded by T. Bender. Roll call resulted as follows:

P. Battaglia -	Yes	C. Yunker -	Yes
T. Bender -	Yes	P. Zeff -	Yes
C. Klotzbach -	Yes	M. Gray -	Yes
A. Vanderhoof -	Yes		

The item was approved as presented.

3.0 Report of Management

3.1 LandPro Equipment, LLC – Initial Resolution - LandPro Equipment LLC will acquire and develop a 14-acre parcel in the town of Batavia, including the construction of a 50,000 square-foot facility for a full-service John Deere Agriculture and Turf Dealership. 95% of the facility will be used for parts, service, and training, with 5% used for retail.

The company pledges to create 5 new jobs and retain 62 existing jobs as part of the \$7 million project. The facility will service a customer base within a 50-mile radius of Batavia, NY and expand workforce training programs for the benefit of the company and Genesee County's workforce.

The project will produce an estimated \$5.3 million in regional and state benefits, including \$4.8 million in estimated temporary (construction) and ongoing payroll for the 5 new jobs, \$237,000 in property tax

revenue and \$121,000 in sales tax revenue during the incentives period. The company has requested property, sales and mortgage tax abatements totaling \$731,000.

A public hearing will be held as benefits are estimated to be over \$100,000

Resolution No. 02/2021 - 01

RESOLUTION OF THE GENESEE COUNTY INDUSTRIAL DEVELOPMENT AGENCY D/B/A GENESEE COUNTY ECONOMIC DEVELOPMENT CENTER (THE "AGENCY") (i) ACCEPTING AN APPLICATION WITH RESPECT TO A CERTAIN PROJECT (AS DEFINED BELOW, THE "PROJECT") FOR THE BENEFIT OF LANDPRO EQUIPMENT LLC, (ii) AUTHORIZING A PUBLIC HEARING WITH RESPECT TO THE PROJECT, AND (iii) DESCRIBING THE FORMS OF FINANCIAL ASSISTANCE BEING CONTEMPLATED BY THE AGENCY WITH RESPECT TO THE PROJECT.

P. Battaglia made a motion to accept initial resolution #02/2021-01, authorizing the scheduling of a public hearing; the motion was seconded by A. Vanderhoof. Roll call resulted as follows:

P. Battaglia -	Yes	C. Yunker -	Yes
T. Bender -	Yes	P. Zelif -	Yes
C. Klotzbach -	Yes	M. Gray -	Absent
A. Vanderhoof -	Absent		

The item was approved as presented.

S. Hyde outlined a report on employment metrics which the Economic Recovery Task Force has been tracking since the beginning of the pandemic. From the end of March 2020 to the end of April 2020, 2300 jobs were lost in Genesee County. This is a decrease of 10.4%. By the end of 2020, jobs were down by only 800. This is a recovery of 65% of jobs lost. The leisure and hospitality sector was impacted the most, down by 44%. It has experienced the least amount of recovery as it is still down by 35%.

4.0 Audit & Finance Committee

4.1 December 2020 Unaudited Financial Statements- L. Farrell noted the following:

- On the Balance sheet, restricted cash decreased. In December, we had a large draw on our ESD grants using our imprest cash funds. We are still waiting to receive approximately \$2M into the imprest account for the \$8M ESD grant, which the Comptroller's office approved on 1/4/2021.
- Pre-paid expenses increased. In December, the annual New York State Retirement invoice was paid. This payment covers through March 31, 2021
- Accounts payable increased which includes STAMP payables. The next round of GURFs are in process which included 2020 expenditures that will be paid in 2021.
- On the P&L, we closed on three solar projects, including Townline Batavia Solar and both Knapp solar projects. Fee revenue is almost double what we budgeted for 2020.
- Revenues are over budget, while most operating expenses are under budget.

This was recommended for approval by the Committee.

M. Gray made a motion to approve the December 2020 Unaudited Financial Statements as presented; the motion was seconded by A. Vanderhoof. Roll call resulted as follows:

P. Battaglia -	Yes	C. Yunker -	Yes
T. Bender -	Yes	P. Zeff -	Yes
C. Klotzbach -	Yes	M. Gray -	Yes
A. Vanderhoof -	Yes		

The item was approved as presented.

4.2 General Liability Insurance – The Board previously approved extending insurance coverage with Selective Insurance through the end of February 2021 while Tompkins worked on obtaining alternative insurance proposals. Tompkins went out to bid for the Agency’s 2021 insurance renewal. Other markets were explored as listed in the Board packet materials, but they were unable to find another carrier that was able to meet the GCEDC’s needs at an affordable rate. The total premium proposed by Selective is within the amounts included in the EDC and LDC budgets.

This was recommended for approval by the Committee.

M. Gray made a motion to approve general liability insurance with Selective as presented; the motion was seconded by A. Vanderhoof. Roll call resulted as follows:

P. Battaglia -	Yes	C. Yunker -	Yes
T. Bender -	Yes	P. Zeff -	Yes
C. Klotzbach -	Yes	M. Gray -	Yes
A. Vanderhoof -	Yes		

The item was approved as presented.

4.3 D & O Insurance – Lawley Insurance has provided us with a proposal for renewal of our current Directors & Officers/Employment Practices Liability Insurance with Travelers. The renewal price reflects an overall price increase of only \$528 (\$264/entity) compared to the current policy. The current policy expires on 2/23/2021.

The cost of this policy would be split between GCEDC and GGLDC (\$5,496/entity) and is within each entity’s budget for 2021.

Coverage for the new Water and Sewer Works Transportation Corporations has not been included in this proposal. These entities can be added when we have more information to provide.

This was recommended for approval by the Committee.

M. Gray made a motion to approve the renewal of D & O insurance with Travelers as presented; the motion was seconded by P. Battaglia. Roll call resulted as follows:

P. Battaglia -	Yes	C. Yunker -	Yes
T. Bender -	Yes	P. Zeff -	Yes
C. Klotzbach -	Yes	M. Gray -	Yes
A. Vanderhoof -	Yes		

The item was approved as presented.

4.4. Cyber Insurance – This agenda item was tabled.

4.5 Change Order for Corfu WWTF Expansion – In December of 2019, the GGLDC accepted the bid received from STC Construction for a Base Bid amount of \$4,861,000 and authorizing Change Order No. 1 with a deduct amount of \$500,000.

The GGLDC also accepted the bid received from Concord Electric for a Base Bid amount of \$393,000.

The GGLDC committed the cash on hand in restricted BETP account as of 9/30/19 - \$556,001 (plus any interest earned in the account up to the date of disbursement) and future CBA payments (9 years at \$93,000 per year) unless the debt is paid off early).

The work on the WWTF is almost complete, and there are two additional change orders presented today. One change order from STC and one from Concord Electric.

The town of Pembroke has passed a bonding resolution that will cover the increase in cost as a result of the change orders and is not asking the GGLDC for any additional funds. No additional fund commitment is requested.

This was recommended for approval by the Committee.

P. Zelif made a motion to approve of the change orders for STC Construction, Inc and Concord Electric as presented with no additional commitment of funds; the motion was seconded by P. Battaglia. Roll call resulted as follows:

P. Battaglia -	Yes	C. Yunker -	Yes
T. Bender -	Yes	P. Zelif -	Yes
C. Klotzbach -	Yes	M. Gray -	Yes
A. Vanderhoof -	Yes		

The item was approved as presented.

5.0 Governance & Nominating Committee – C. Yunker

5.1 Authority Self-Evaluation of Prior Year Performance - Public Authorities are required to perform a self-evaluation of prior year's goals/measurements annually. This report shows the results against the goals and measurements that were set for 2020. This report will be submitted into PARIS.

C. Yunker reviewed the highlights of the Authority self-evaluation that the Committee discussed in detail. The Agency set a goal of capital investment commitment of \$32M for 2020. The actual result from projects was \$83M for 2020. The Agency also pledged to create 90 jobs from projects in 2020. These projects resulted in 78 jobs pledged in 2020 but did not include jobs related to the Rochester Regional Health bond transaction because they failed to report.

This was recommended for approval by the Committee.

C. Yunker made a motion to approve the Authority Self-Evaluation of Prior Year Performance; the motion was seconded by P. Battaglia. Roll call resulted as follows:

P. Battaglia -	Yes	C. Yunker -	Yes
T. Bender -	Yes	P. Zelif -	Yes
C. Klotzbach -	Yes	M. Gray -	Yes
A. Vanderhoof -	Yes		

The item was approved as presented.

5.2 Mission Statement & Measurement Report - The Authority's Board must annually review the authority's mission statement and performance goals to ensure that its mission has not changed and that the authority's performance goals continue to support its mission. This report will be posted to the website and submitted into PARIS.

C. Yunker reviewed the highlights of the Mission Statement and Measurement Report that the Committee discussed in detail. The Committee recommends that the Agency set a goal of capital investment commitment of \$35M for 2021, which does not include any Mega projects (over \$50M capital investment commitment). The Committee also recommends the Agency set a job creation goal of 90 jobs from projects in 2021. The other suggested goals are over-arching goals that the entire staff can work towards achieving and are still consistent with the Agency's mission.

This was recommended for approval by the Committee.

C. Yunker made a motion to approve the Mission Statement & Measurement Report with the amendment that the capital investment commitment excludes any Mega project(s); the motion was seconded by P. Battaglia. Roll call resulted as follows:

P. Battaglia -	Yes	C. Yunker -	Yes
T. Bender -	Yes	P. Zelif -	Yes
C. Klotzbach -	Yes	M. Gray -	Yes
A. Vanderhoof -	Yes		

The item was approved as presented.

6.0 STAMP Committee – P. Zelif

6.1 Phillips Lytle Proposal – STAMP Main Substation – The proposal from Phillips Lytle is to provide legal, regulatory, and overall planning support from their energy law and consulting practice at Phillips Lytle. This is to foster completion of the design and engineering of the STAMP Main substation and related interconnection studies as well as to advance necessary ownership, operations and maintenance, regulatory and pricing models to enable the bidding, construction and operations of the 345V to 115V main substation at STAMP.

Fund commitment: Not to exceed \$40,000 from Empire State Development's GCEDC STAMP Capital (Project #132,367)

This was recommended for approval by the Committee.

P. Zelif made a motion to approve the Phillips Lytle proposal not to exceed \$40,000; the motion was seconded by C. Klotzbach. Roll call resulted as follows:

P. Battaglia -	Yes	C. Yunker -	Yes
T. Bender -	Yes	P. Zelif -	Yes
C. Klotzbach -	Yes	M. Gray -	Yes
A. Vanderhoof -	Yes		

The item was approved as presented.

6.2 Project Gateway SEQR – M. Masse provided an update on SEQR concerning Project Gateway. The GCEDC was lead agency when the original Environment Impact Study (EIS) was completed on the STAMP site in 2012. Since the original EIS, there have been additional updates and the GCEDC remained lead agency for these as well. On January 4, 2021, the GCEDC sent letters indicating intent to maintain lead agency status regarding Project Gateway to all interested and involved parties. The GCEDC received two affirmations consenting lead agency status and no other responses. As a result, after 30 days, the GCEDC is lead agency. As lead agency the GCEDC is required to evaluate whether there are adverse environmental impacts because of Project Gateway that have not been previously evaluated in the STAMP environmental record. After careful review, it was determined that there are no significant adverse environmental impacts that would be created by this project that had not previously been analyzed. No mitigation is necessary if Project Gateway commits to the best practices outlined in the EIS. The GCEDC is in a position to adopt the resolution included with Committee and Board materials.

This was recommended for approval by the Committee.

Resolution No. 02/2021 – 02

RESOLUTION OF THE GENESEE COUNTY INDUSTRIAL DEVELOPEMNT AGENCY D/B/A GENESEE COUNTY ECONOMIC DEVELOPMENT CENTER PURSUANT TO THE STATE ENVIRONMENTAL QUALITY REVIEW ACT CONCERNING PROJECT GATEWAY - PROPOSED FUTURE USE OF A PORTION OF THE WESTERN NEW YORK SCIENCE & TECHNOLOGY ADVANCED MANUFACTURING PARK

P. Zeliff made a motion to approve Resolution #02/2021-02 as presented; the motion was seconded by C. Yunker. Roll call resulted as follows:

P. Battaglia -	Yes	C. Yunker -	Yes
T. Bender -	Yes	P. Zeliff -	Yes
C. Klotzbach -	Yes	M. Gray -	Yes
A. Vanderhoof -	Yes		

The item was approved as presented.

7.0 Employment & Compensation – T. Bender

7.1 CEO Merit / COLA – This was recommended for approval by the Committee.

T. Bender made a motion to approve a CEO Merit /COLA Adjustment of 1.5%; the motion was seconded by A. Vanderhoof. Roll call resulted as follows:

P. Battaglia -	Yes	C. Yunker -	Yes
T. Bender -	Yes	P. Zeliff -	Yes
C. Klotzbach -	Yes	M. Gray -	Yes
A. Vanderhoof -	Yes		

The item was approved as presented.

8.0 Housing Committee – P. Battaglia

8.1 Nothing at this time.

9.0 Other Business

10.0 Adjournment

As there was no further business, T. Bender made a motion to adjourn at 5:14 p.m., which was seconded by A. Vanderhoof and passed unanimously.

Appendix J

NYS Stormwater Management Design Manual

Appendix H

H.1 Ponds and Wetlands

For areas that are to be planted within a stormwater pond, it is necessary to determine what type of hydrologic zones will be created within the pond. The following six zones describe the different conditions encountered in stormwater management facilities. Every facility does not necessarily reflect all of these zones. The hydrologic zones designate the degree of tolerance the plant exhibits to differing degrees of inundation by water.

Table H.5 at the end of this appendix designates appropriate zones for each plant. There may be other zones listed outside of these brackets. The plant materials may occur within these zones, but are not typically found in them. Plants suited for specific hydrologic conditions may perish when those conditions change, exposing the soil, and therefore, increasing the chance for erosion.

Each zone has its own set of plant selection criteria based on the hydrology of the zone, the stormwater functions required of the plant and the desired landscape effect. The hydrologic zones are as follows:

<u>Zone #</u>	<u>Zone Description</u>	<u>Hydrologic Conditions</u>
Zone 1	Deep Water Pool	1-6 feet deep Permanent Pool
Zone 2	Shallow Water Bench	6 inches to 1 foot deep
Zone 3	Shoreline Fringe	Regularly inundated
Zone 4	Riparian Fringe	Periodically inundated
Zone 5	Floodplain Terrace	Infrequently inundated
Zone 6	Upland Slopes	Seldom or never inundated

Zone 1: Deep Water Area (1- 6 Feet)

Ponds and wetlands both have deep pool areas that comprise Zone 1. These pools range from one to six feet in depth, and are best colonized by submergent plants, if at all.

This pondscaping zone has not been routinely planted for several reasons. First, the availability of plant materials that can survive and grow in this zone is limited, and it is also feared that plants could clog the stormwater facility outlet structure. In many cases, these plants will gradually become established through natural recolonization (e.g., transport of plant fragments from other ponds via the feet and legs of waterfowl). If submerged plant material becomes more commercially available and clogging concerns are addressed, this area can be planted. The function of the planting is to reduce resedimentation and improve oxidation while creating a greater aquatic habitat.

- ▶ Plant material must be able to withstand constant inundation of water of one foot or greater in depth.
- ▶ Plants may be submerged partially or entirely.
- ▶ Plants should be able to enhance pollutant uptake.
- ▶ Plants may provide food and cover for waterfowl, desirable insects, and other aquatic life.

Zone 2: Shallow Water Bench (*Normal Pool To 1 Foot*)

Zone 2 includes all areas that are inundated below the normal pool to a depth of one foot, and is the primary area where emergent plants will grow in a stormwater wetlands. Zone 2 also coincides with the aquatic bench found in stormwater ponds. This zone offers ideal conditions for the growth of many emergent wetland species. These areas may be located at the edge of the pond or on low mounds of earth located below the surface of the water within the pond. When planted, Zone 2 can be an important habitat for many aquatic and nonaquatic animals, creating a diverse food chain. This food chain includes predators, allowing a natural regulation of mosquito populations, thereby reducing the need for insecticidal applications.

- ▶ Plant material must be able to withstand constant inundation of water to depths between six inches and one foot deep.
- ▶ Plants will be partially submerged.
- ▶ Plants should be able to enhance pollutant uptake.
- ▶ Plants may provide food and cover for waterfowl, desirable insects and other aquatic life.

Plants will stabilize the bottom of the pond, as well as the edge of the pond, absorbing wave impacts and reducing erosion, when water level fluctuates. Plant also slow water velocities and increase sediment deposition rates. Plants can reduce resuspension of sediments caused by the wind. Plants can also soften the engineered contours of the pond, and can conceal drawdowns during dry weather.

Zone 3: Shoreline Fringe (*Regularly Inundated*)

Zone 3 encompasses the shoreline of a pond or wetland, and extends vertically about one foot in elevation from the normal pool. This zone includes the safety bench of a pond, and may also be periodically inundated if storm events are subject to extended detention. This zone occurs in a wet pond or shallow marsh and can be the most difficult to establish since plants must be able to withstand inundation of water during storms, when wind might blow water into the area, or the occasional drought during the summer. In order to stabilize the soil in this zone, Zone 3 must have a vigorous cover.

- ▶ Plants should stabilize the shoreline to minimize erosion caused by wave and wind action or water fluctuation.
- ▶ Plant material must be able to withstand occasional inundation of water. Plants will be partially submerged at this time.
- ▶ Plant material should, whenever possible, shade the shoreline, especially the southern exposure. This will help to reduce the water temperature.

- ▶ Plants should be able to enhance pollutant uptake.
- ▶ Plants may provide food and cover for waterfowl, songbirds, and wildlife. Plants could also be selected and located to control overpopulation of waterfowl.
- ▶ Plants should be located to reduce human access, where there are potential hazards, but should not block the maintenance access.
- ▶ Plants should have very low maintenance requirements, since they may be difficult or impossible to reach.
- ▶ Plants should be resistant to disease and other problems which require chemical applications (since chemical application is not advised in stormwater ponds).

Zone 4: Riparian Fringe (*Periodically Inundated*)

Zone 4 extends from one to four feet in elevation above the normal pool. Plants in this zone are subject to periodic inundation after storms, and may experience saturated or partly saturated soil conditions. Nearly all of the temporary ED area is included within this zone.

- ▶ Plants must be able to withstand periodic inundation of water after storms, as well as occasional drought during the warm summer months.
- ▶ Plants should stabilize the ground from erosion caused by run-off.
- ▶ Plants should shade the low flow channel to reduce the pool warming whenever possible.
- ▶ Plants should be able to enhance pollutant uptake.
- ▶ Plant material should have very low maintenance, since they may be difficult or impossible to access.
- ▶ Plants may provide food and cover for waterfowl, songbirds and wildlife. Plants may also be selected and located to control overpopulation of waterfowl.
- ▶ Plants should be located to reduce pedestrian access to the deeper pools.

Zone 5: Floodplain Terrace (*Infrequently Inundated*)

Zone 5 is periodically inundated by flood waters that quickly recedes in a day or less. Operationally, Zone 5 extends from the maximum two year or C_{pv} water surface elevation up to the 10 or 100 year maximum water surface elevation. Key landscaping objectives for Zone 5 are to stabilize the steep slopes characteristic of this zone, and establish a low maintenance, natural vegetation.

- ▶ Plant material should be able to withstand occasional but brief inundation during storms, although typical moisture conditions may be moist, slightly wet, or even swing entirely to drought conditions during the dry weather periods.
- ▶ Plants should stabilize the basin slopes from erosion.
- ▶ Ground cover should be very low maintenance, since they may be difficult to access on steep slopes or if frequency of mowing is limited. A dense tree cover may help reduce maintenance and discourage resident geese.
- ▶ Plants may provide food and cover for waterfowl, songbirds, and wildlife.

- ▶ Placement of plant material in Zone 5 is often critical, as it often creates a visual focal point and provides structure and shade for a greater variety of plants.

Zone 6: Upland Slopes (*Seldom or Never Inundated*)

The last zone extends above the maximum 100 year water surface elevation, and often includes the outer buffer of a pond or wetland. Unlike other zones, this upland area may have sidewalks, bike paths, retaining walls, and maintenance access roads. Care should be taken to locate plants so they will not overgrow these routes or create hiding places that might make the area unsafe.

- ▶ Plant material is capable of surviving the particular conditions of the site. Thus, it is not necessary to select plant material that will tolerate any inundation. Rather, plant selections should be made based on soil condition, light, and function within the landscape.
- ▶ Ground covers should emphasize infrequent mowing to reduce the cost of maintaining this landscape.
- ▶ Placement of plants in Zone 6 is important since they are often used to create a visual focal point, frame a desirable view, screen undesirable views, serve as a buffer, or provide shade to allow a greater variety of plant materials. Particular attention should be paid to seasonal color and texture of these plantings.

H.2 Bioretention

Planting Soil Bed Characteristics

The characteristics of the soil for the bioretention facility are perhaps as important as the facility location, size, and treatment volume. The soil must be permeable enough to allow runoff to filter through the media, while having characteristics suitable to promote and sustain a robust vegetative cover crop. In addition, much of the nutrient pollutant uptake (nitrogen and phosphorus) is accomplished through adsorption and microbial activity within the soil profile. Therefore, the soils must balance soil chemistry and physical properties to support biotic communities above and below ground.

The planting soil should be a sandy loam, loamy sand, loam (USDA), or a loam/sand mix (should contain a minimum 35 to 60% sand, by volume). The clay content for these soils should be less than 25% by volume. Soils should fall within the SM, or ML classifications of the Unified Soil Classification System (USCS). A permeability of at least 1.0 feet per day (0.5"/hr) is required (a conservative value of 0.5 feet per day is used for design). The soil should be free of stones, stumps, roots, or other woody material over 1" in diameter. Brush or seeds from noxious weeds. Placement of the planting soil should be in lifts of 12 to 18", loosely compacted (tamped lightly with a dozer or backhoe bucket). The specific characteristics are presented in Table H.2.

Table H.2 Planting Soil Characteristics

Parameter	Value
PH range	5.2 to 7.00
Organic matter	1.5 to 4.0%
Magnesium	35 lbs. per acre, minimum
Phosphorus (P ₂ O ₅)	75 lbs. per acre, minimum
Potassium (K ₂ O)	85 lbs. per acre, minimum
Soluble salts	≤ 500 ppm
Clay	10 to 25%
Silt	30 to 55%
Sand	35 to 60%

Mulch Layer

The mulch layer plays an important role in the performance of the bioretention system. The mulch layer helps maintain soil moisture and avoid surface sealing which reduces permeability. Mulch helps prevent erosion, and provides a micro-environment suitable for soil biota at the mulch/soil interface. It also serves as a pretreatment layer, trapping the finer sediments which remain suspended after the primary pretreatment.

The mulch layer should be standard landscape style, single or double, shredded hardwood mulch or chips. The mulch layer should be well aged (stockpiled or stored for at least 12 months), uniform in color, and free of other materials, such as weed seeds, soil, roots, etc. The mulch should be applied to a maximum depth of three inches. Grass clippings should not be used as a mulch material.

Planting Plan Guidance

Plant material selection should be based on the goal of simulating a terrestrial forested community of native species. Bioretention simulates an ecosystem consisting of an upland-oriented community dominated by trees, but having a distinct community, or sub-canopy, of understory trees, shrubs and herbaceous materials. The intent is to establish a diverse, dense plant cover to treat stormwater runoff and withstand urban stresses from insect and disease infestations, drought, temperature, wind, and exposure.

The proper selection and installation of plant materials is key to a successful system. There are essentially three zones within a bioretention facility (Figure H.1). The lowest elevation supports plant species adapted to standing and fluctuating water levels. The middle elevation supports a slightly drier group of plants, but still tolerates fluctuating water levels. The outer edge is the highest elevation and generally supports plants adapted to dryer conditions. When using Table A.5 to identify species, use the following guideline:

Lowest Zone: Zones 2-3

Middle Zone: Zones 3-4

Outer Zone: Zones 5-6

The layout of plant material should be flexible, but should follow the general principals described in Table H.3. The objective is to have a system which resembles a random and natural plant layout, while maintaining optimal conditions for plant establishment and growth.

Figure H.1 Planting Zones for Bioretention Facilities

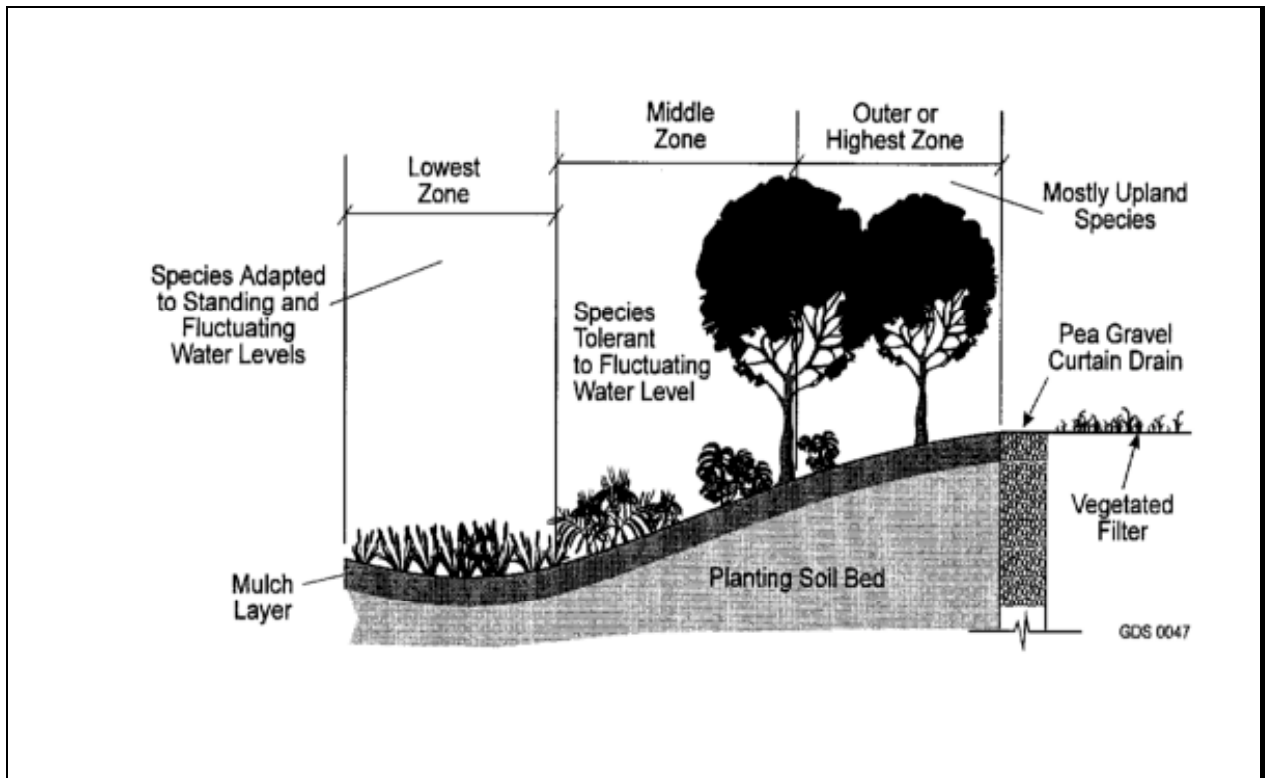

Table H.3 Planting Plan Design Considerations
Native plant species should be specified over exotic or foreign species.
Appropriate vegetation should be selected based on the zone of hydric tolerance (see Figure H.1).
Species layout should generally be random and natural.
A canopy should be established with an understory of shrubs and herbaceous materials.
Woody vegetation should not be specified in the vicinity of inflow locations.
Trees should be planted primarily along the perimeter of the bioretention area.
Urban stressors (e.g., wind, sun, exposure, insect and disease infestation, drought) should be considered when laying out the planting plan.
Noxious weeds should not be specified.
Aesthetics and visual characteristics should be a prime consideration.
Traffic and safety issues must be considered.
Existing and proposed utilities must be identified and considered.

Plant Material Guidance

Plant materials should conform to the American Standard Nursery Stock, published by the American Association of Nurserymen, and should be selected from certified, reputable nurseries. Planting specifications should be prepared by the designer and should include a sequence of construction, a description of the contractor's responsibilities, a planting schedule and installation specifications, initial maintenance, and a warranty period and expectations of plant survival. Table H.4 presents some typical issues for planting specifications.

Table H.4 Planting Specification Issues for Bioretention Areas	
Specification Element	Elements
Sequence of Construction	Describe site preparation activities, soil amendments, etc.; address erosion and sediment control procedures; specify step-by-step procedure for plant installation through site clean-up.
Contractor's Responsibilities	Specify the contractor's responsibilities, such as watering, care of plant material during transport, timeliness of installation, repairs due to vandalism, etc.
Planting Schedule and Specifications	Specify the materials to be installed, the type of materials (e.g., B&B, bare root, containerized); time of year of installations, sequence of installation of types of plants; fertilization, stabilization seeding, if required; watering and general care.
Maintenance	Specify inspection periods; mulching frequency (annual mulching is most common); removal and replacement of dead and diseased vegetation; treatment of diseased trees; watering schedule after initial installation (once per day for 14 days is common); repair and replacement of staking and wires.
Warranty	Specify the warranty period, the required survival rate, and expected condition of plant species at the end of the warranty period.

Table H.5 Native Plant Guide for Stormwater Management Areas (NY)						
Plant Name	Zone	Form	Available	Inundation Tolerance	Wildlife Value	Notes
Trees and Shrubs						
American Elm (<i>Ulmus americana</i>)	4,5,6	Dec. Tree	yes	Irregular-seasonal saturation	High. Food (seeds, browsing), cover, nesting for birds & mammals	Susceptible to disease (short-lived). Sun to full shade, tolerates drought and wind/ice damage.
Arrowwood Viburnum (<i>Viburnum dentatum</i>)	3,4	Dec. Shrub	yes	yes	High. Songbirds and mammals	Grows best in sun to partial shade
Bald Cypress (<i>Taxodium distichum</i>)	3,4	Dec. Tree	yes	yes	Little food value, but good perching site for waterfowl	Forested Coastal Plain. North of normal range. Tolerates drought.
Bayberry (<i>Myrica pensylvanica</i>)	4,5,6	Dec. Shrub	yes	yes	High. Nesting, food, cover. Berries last into winter	Coastal Plain only. Roots fix N ₂ . Tolerates slightly acidic soils.
Black Ash (<i>Fraxinus nigra</i>)	3,4,5	Dec. Tree	yes	Irregular-seasonal saturation	High. Food (seeds, sap), cover, nesting for birds & mammals. Fruit persists in winter	Rapid growth. Requires full sun. Susceptible to wind/ice damage & disease. Tolerates drought and infrequent flooding by salt water.
Black Cherry (<i>Prunus serotina</i>)	5,6	Dec. Tree	yes	no	High. Food	Moist soils or wet bottomland areas
Blackgum or Sourgum (<i>Nyssa sylvatica</i>)	4,5,6	Dec. Tree	yes	yes	High. Songbirds, egrets, herons, raccoons, owls	Can be difficult to transplant. Prefers sun to partial shade
Black Willow (<i>Salix nigra</i>)	3,4,5	Dec. Tree	yes	yes	High. Browsing and cavity nesters.	Rapid growth, stabilizes stream-banks. Full sun
Buttonbush (<i>Cephalanthus occidentalis</i>)	2,3,4,5	Dec. Shrub	yes	yes	High. Ducks and shorebirds. Seeds, nectar and nesting.	Full sun to partial shade. Will grow in dry areas.
Common Spice Bush (<i>Lindera benzoin</i>)	3,4,5	Dec. Shrub	yes	yes	Very high. Songbirds	Shade and rich soils. Tolerates acidic soils. Good understory species

Table H.5 Native Plant Guide for Stormwater Management Areas (NY)						
Plant Name	Zone	Form	Available	Inundation Tolerance	Wildlife Value	Notes
Eastern Cottonwood (<i>Populus deltoides</i>)	4,5	Dec. Tree	yes	yes	Moderate. Cover, food.	Shallow rooted, subject to windthrow. Invasive roots. Rapid growth.
Eastern Hemlock (<i>Tsuga canadensis</i>)	5,6	Conif Tree	yes	yes	Moderate. Mostly cover and some food	Tolerates all sun/shade conditions. Tolerates acidic soil.
Eastern Red Cedar (<i>Juniperus virginiana</i>)	4,5,6	Conif Tree	yes	no	High. Fruit for birds. Some cover.	Full sun to partial shade. Common in wetlands, shrub bogs and edge of stream
Elderberry (<i>Sambucus canadensis</i>)	3,4,5,6	Dec. Shrub	yes	yes	Extremely high. Food and cover, birds and mammals.	Full sun to partial shade.
Green Ash, Red Ash (<i>Fraxinus pennsylvanica</i>)	4,5	Dec. Tree	yes	yes	Moderate. Songbirds.	Rapid growing streambank stabilizer. Full sun to partial shade.
Hackberry (<i>Celtis occidentalis</i>)	5,6	Dec. Tree	yes	some	High. Food and cover	Full sun to partial shade.
Larch, Tamarack (<i>Larix laricina</i>)	3,4	Conif Tree	no	yes	Low. Nest tree and seeds.	Rapid initial growth. Full sun, acidic boggy soil.
Pin Oak (<i>Quercus palustris</i>)	3,4,5,6	Dec. Tree	yes	yes	High. Tolerates acidic soil	Gypsy moth target. Prefers well drained, sandy soils.
Red Choke Berry (<i>Pyrus arbutifolia</i>)	3,4,5	Dec. Shrub	no	yes	Moderate. Songbirds.	Bank stabilizer. Partial sun.
Red Maple (<i>Acer rubrum</i>)	3,4,5,6	Dec. Tree	yes	yes	High seeds and browse. Tolerates acidic soil.	Rapid growth.
River Birch (<i>Betula nigra</i>)	3,4,5	Dec. Tree	yes	yes	Low. Good for cavity nesters.	Bank erosion control. Full sun.
Shadowbush, Serviceberry (<i>Amelanchier</i>)	4,5,6	Dec. Shrub	yes	yes	High. Nesting, cover, food. Birds and	Prefers partial shade. Common in forested

Table H.5 Native Plant Guide for Stormwater Management Areas (NY)						
Plant Name	Zone	Form	Available	Inundation Tolerance	Wildlife Value	Notes
<i>canadensis</i>)					mammals.	wetlands and upland woods.
Silky Dogwood (<i>Cornus amomium</i>)	3,4,5	Dec. Shrub	yes	yes	High. Songbirds, mammals.	Shade and drought tolerant. Good bank stabilizer.
Slippery Elm (<i>Ulmus rubra</i>)	3,4,5	Dec. Tree	rare	yes	High. Food (seeds, buds) for birds & mammals (browse). Nesting	Rapid growth, no salinity tolerance. Tolerant to shade and drought.
Smooth Alder (<i>Alnus serrulata</i>)	3,4,5	Dec. Tree	no	yes	High. Food, cover.	Rapid growth. Stabilizes streambanks.
Speckled Alder (<i>Alnus rugosa</i>)	3,4	Dec. Shrub	yes	yes	High. Cover, browse for deer, seeds for bird.	
Swamp White Oak (<i>Quercus bicolor</i>)	3,4,5	Dec. Tree	yes	yes	High. Mast	Full sun to partial shade. Good bottomland tree.
Swamp Rose (<i>Rosa Palustris</i>)	3,4	Dec. Shrub		Irregular, seasonal, or regularly saturated	High. Food (hips) for birds including turkey, ruffed grouse and mammals. Fox cover.	Prefers full sun. Easy to establish. Low salt tolerance.
Sweetgum (<i>Liquidambar styraciflua</i>)	4,5,6	Dec. Tree	yes	yes	Moderate. Songbirds	Tolerates acid or clay soils. Sun to partial shade.
Sycamore (<i>Platanus occidentalis</i>)	4,5,6,	Dec. Tree	yes	yes	Low. Food, cavities for nesting.	Rapid growth. Common in floodplains and alluvial woodlands.
Tulip Tree (<i>Liriodendron tulipifera</i>)	5,6	Dec. Tree	yes	no	Moderate. Seeds and nest sites	Full sun to partial shade. Well drained soils. Rapid growth.
Tupelo (<i>Nyssa sylvatica vari biflora</i>)	3,4,5	Dec. Tree	yes	yes	High. Seeds and nest sites	Ornamental

Table H.5 Native Plant Guide for Stormwater Management Areas (NY)						
Plant Name	Zone	Form	Available	Inundation Tolerance	Wildlife Value	Notes
White Ash (<i>Fraxinus americana</i>)	5,6	Dec. Tree	yes	no	High. Food	All sunlight conditions. Well drained soils.
Winterberry (<i>Ilex verticillata</i>)	3,4,5	Dec. Shrub	yes	yes	High. Cover and fruit for birds. Holds berries into winter.	Full sun to partial shade. Seasonally flooded areas.
Witch Hazel (<i>Hamamelis virginiana</i>)	4,5	Dec. Shrub	yes	no	Low. Food for squirrels, deer, and ruffed grouse.	Prefers shade. Ornamental.
Herbaceous Plants						
Arrow arum (<i>Peltandra virginica</i>)	2,3	Emergent	yes	up to 1 ft.	High. Berries are eaten by wood ducks.	Full sun to partial shade.
Arrowhead, Duck Potato (<i>Sagittaria latifolia</i>)	2,3	Emergent	yes	up to 1 ft.	Moderate. Tubers and seeds eaten by ducks.	Aggressive colonizer.
Big Bluestem (<i>Andropogon gerardi</i>)	4,5	Perimeter	yes	Irregular or seasonal inundation.	High. Seeds for songbirds. Food for deer	Requires full sun.
Birdfoot deervetch (<i>Lotus Corniculatus</i>)	4,5,6	Perimeter	yes	Infrequent inundation	High. Food for birds.	Full sun. Nitrogen fixer.
Blue Flag Iris (<i>Iris versicolor</i>)	2,3	Emergent	yes	Regular or permanently, up to ½ ft or saturated	Moderate. Food muskrat and wildfowl. Cover, marshbirds	Slow growth. Full sun to partial shade. Tolerates clay. Fresh to moderately brackish water.
Blue Joint (<i>Calamagrotis canadensis</i>)	2,3,4	Emergent	yes	Regular or permanent inundation up to 0.5 ft.	Moderate. Food for game birds and moose.	Tolerates partial shade
Broomsedge (<i>Andropogon virginicus</i>)	2,3	Perimeter	yes	up to 3 in.	High. Songbirds and browsers. Winter food and cover.	Tolerant of fluctuation water levels & partial shade.
Bushy Beardgrass (<i>Andropogon glomeratus</i>)	2,3	Emergent	yes	up to 1 ft.		Requires full sun.
Cardinal flower (<i>Lobelia cardinalis</i>)	4,5,6	Perimeter	yes	Some. Tolerates saturation up to 100% of season.	High. Nectar for hummingbird, oriole, butterflies.	Tolerates partial shade

Table H.5 Native Plant Guide for Stormwater Management Areas (NY)						
Plant Name	Zone	Form	Available	Inundation Tolerance	Wildlife Value	Notes
Cattail (<i>Typha sp.</i>)	2,3	Emergent	yes	up to 1 ft.	Low. Except as cover	Aggressive. May eliminate other species. Volunteer. High pollutant treatment
Coontail (<i>Ceratophyllum demersum</i>)	1	Submergent	no	yes	Low food value. Good habitat and shelter for fish and invertebrates.	Free floating SAV. Shade tolerant. Rapid growth.
Common Three-Square (<i>Scirpus pungens</i>)	2	Emergent	yes	up to 6 in.	High. Seeds, cover. Waterfowl and fish.	High metal removal.
Duckweed (<i>Lemna sp.</i>)	1,2	Submergent/ Emergent	yes	yes	High. Food for waterfowl and fish.	High metal removal.
Fowl mannagrass (<i>Glyceria striata</i>)	4,5	Perimeter	yes	Irregular or seasonal inundation	High. Food for waterfowl, muskrat, and deer.	Partial to full shade.
Hardstem Bulrush (<i>Scirpus acutus</i>)	2	Emergent	yes	up to 3 ft.	High. Cover, food (achenes, rhizomes) ducks, geese, muskrat, fish. Nesting for bluegill and bass.	Quick to establish, fresh to brackish. Good for sediment stabilization and erosion control.
Giant Burreed (<i>Sparganium eurycarpum</i>)	2,3	Emergent	rare	Regular to permanently inundated. up to 1 ft.	High. Food (seeds, plant) waterfowl, beaver & other mammals. Cover for marshbirds, waterfowl.	Rapid spreading. Tolerates partial sun. Good for shoreline stabilization.. Salinity <0.5 ppt
Lizard's Tail (<i>Saururus cernuus</i>)	2	Emergent	yes	up to 1 ft.	Low, except wood ducks.	Rapid growth. Shade tolerant
Long-leaved Pond Weed (<i>Potamogeton nodosus</i>)	1,2	Rooted submerged aquatic	yes	up to 1-6 ft. depending on turbidity	High. Food (seeds, roots) waterfowl, aquatic fur-bearers, deer, moose. Habitat for fish	Rapid spread. Salinity <0.5 ppt. Flowers float on surface, Aug.-Sept.

Table H.5 Native Plant Guide for Stormwater Management Areas (NY)						
Plant Name	Zone	Form	Available	Inundation Tolerance	Wildlife Value	Notes
Marsh Hibiscus (<i>Hibiscus moscheutos</i>)	2,3	Emergent	yes	up to 3 in.	Low. Nectar.	Full sun. Can tolerate periodic dryness.
Pickeralweed (<i>Pontederia cordata</i>)	2,3	Emergent	yes	up to 1 ft.	Moderate. Ducks. Nectar for butterflies.	Full sun to partial shade.
Pond Weed, Sago (<i>Potamogeton pectinatus</i>)	1	Submergent	yes	yes	Extremely high. Waterfowl, marsh and shorebirds.	Removes heavy metals.
Redtop (<i>Agrostis alba</i>)	3,4,5	Perimeter	yes	Up to 25% of season	Moderate. Rabbits and some birds.	Quickly established but not highly competitive.
Rice Cutgrass (<i>Leersia oryzoides</i>)	2,3	Emergent	yes	up to 3 in.	High. Food and cover.	Full sun although tolerant of shade. Shoreline stabilization.
Sedges (<i>Carex spp.</i>)	2,3	Emergent	yes	up to 3 in.	High waterfowl, songbirds.	Many wetland and upland species.
Tufted Hairgrass (<i>Deschampsia caespitosa</i>)	3,4,5	Perimeter	yes	Regular to irregular inundation.	High.	Full sun. May become invasive.
Soft-stem Bulrush (<i>Scirpus validus</i>)	2,3	Emergent	yes	up to 1 ft.	Moderate. Good cover and food.	Full sun. Aggressive colonizer. High pollutant removal.
Smartweed (<i>Polygonum spp.</i>)	2,3,4	Emergent	yes	up to 1 ft.	High. Waterfowl, songbirds. Seeds and cover.	Fast colonizer. Avoid weedy aliens such as <i>P. perfoliatum</i> .
Soft Rush (<i>Juncus effusus</i>)	2,3,4	Emergent	yes	up to 3 in.	Moderate.	Tolerates wet or dry conditions.
Spatterdock (<i>Nuphar luteum</i>)	2	Emergent	yes	up to 3 ft.	Moderate for food but high for cover.	Fast colonizer. Tolerant of fluctuating water levels.
Switchgrass (<i>Panicum virgatum</i>)	2,3,4,5,6	Perimeter	yes	up to 3 in.	High. Seeds, cover for waterfowl, songbirds.	Tolerates wet/dry conditions.

Table H.5 Native Plant Guide for Stormwater Management Areas (NY)						
Plant Name	Zone	Form	Available	Inundation Tolerance	Wildlife Value	Notes
Sweet Flag <i>(Acorus calamus)</i>	2,3	Herbaceous	yes	up to 3 in.	Low.	Tolerant of dry periods. Not a rapid colonizer. Tolerates acidic conditions.
Waterweed <i>(Elodea canadensis)</i>	1	Submergent	yes	yes	Low.	Good water oxygenator. High nutrient, copper, manganese and chromium removal.
Wild Celery <i>(Valisneria americana)</i>	1	Submergent	yes	yes	High. Food for waterfowl. Habitat for fish and invertebrates.	Tolerant of murky water and high nutrient loads.
Wild Rice <i>(Zizania aquatica)</i>	2	Emergent	yes	up to 1 ft.	High. Food for birds.	Prefers full sun
Wool Grass <i>(Scirpus cyperinus)</i>	2,3	Emergent	yes	Irregularly to seasonally inundated	Moderate. Cover, Food.	Requires full sun. Can tolerate acidic soils, drought. Colonizes disturbed areas, moderate growth.

Appendix K

Stormwater Control Facility Maintenance Agreement

Town of Alabama

STORMWATER CONTROL FACILITY
MAINTENANCE AGREEMENT

Whereas, the Town of Alabama ("Town") and the _____ ("facility owner") want to enter into an agreement to provide for the long term maintenance and continuation of stormwater control measures approved by the Town for the below named project, and

Whereas, the Town and the facility owner desire that the stormwater control measures be built in accordance with the approved project plans and thereafter be maintained, cleaned, repaired, replaced and continued in perpetuity in order to ensure optimum performance of the components. Therefore, the Town and the facility owner agree as follows:

1. This agreement binds the Town and the facility owner, its successors and assigns, to the maintenance provisions depicted in the approved project plans which are attached as Schedule A of this agreement.
2. The facility owner shall maintain, clean, repair, replace and continue the stormwater control measures depicted in Schedule A as necessary to ensure optimum performance of the measures to design specifications. The stormwater control measures shall include, but shall not be limited to, the following: drainage ditches, swales, dry wells, infiltrators, drop inlets, pipes, culverts, soil absorption devices and retention ponds.
3. The facility owner shall be responsible for all expenses related to the maintenance of the stormwater control measures and shall establish a means for the collection and distribution of expenses among parties for any commonly owned facilities.
4. The facility owner shall provide for the periodic inspection of the stormwater control measures, not less than once in every five-year period, to determine the condition and integrity of the measures. Such inspection shall be performed by a Professional Engineer licensed by the State of New York. The inspecting engineer shall prepare and submit to the Town within 30 days of the inspection, a written report of the findings including recommendations for those actions necessary for the continuation of the stormwater control measures.
5. The facility owner shall not authorize, undertake or permit alteration, abandonment, modification or discontinuation of the stormwater control measures except in accordance with written approval of the Town.
6. The facility owner shall undertake necessary repairs and replacement of the stormwater control measures at the direction of the Town or in accordance with the recommendations of the inspecting engineer.
7. The facility owner shall provide to the Town within 30 days of the date of this agreement, a security for the maintenance and continuation for the stormwater control measures in the form of (a Bond, letter of credit or escrow account).

8. This agreement shall be recorded in the Office of the County Clerk, County of Niagara together with the deed for the common property and shall be included in the offering plan and/or prospectus approved pursuant to _____.
9. If ever the Town determines that the facility owner has failed to construct or maintain the stormwater control measures in accordance with the project plan or has failed to undertake corrective action specified by the Town or by the inspecting engineer, the Town is authorized to undertake such steps as reasonably necessary for the preservation, continuation or maintenance of the stormwater control measures and to affix the expenses thereof as a lien against the property.
10. The agreement is effective _____.

Town of Alabama

Facility Owner

Appendix L

Project Related Correspondence



May 24, 2021

Mr. Bill McGorry
Town of Alabama Planning Board Chair
2218 Judge Road
Oakfield, New York 14125

Dear Mr. McGorry:

The Genesee County Industrial Development Agency d/b/a Genesee County Economic Development Center (GCEDC) is the current owner of the ±97.70 acre parcel with the tax mad ID of 10.-1-42 along Crosby Road within the Western New York Science and Technology Advanced Manufacturing Park (STAMP) located in the Town of Alabama, New York. The GCEDC is currently in the final stages of closing the sale of approximately +/- 29.884 acres to be subdivided out of the aforementioned property to Plug Power.

The intent of this letter is to authorize Scheid Architectural, PLLC to represent and act as Plug Power's agent for the purpose, and through the process of, Town of Alabama and Genesee County Planning Board Site Plan Submission & Approval.

If you have any questions or comments please do not hesitate to contact myself or Scheid Architectural, PLLC as indicated on the attached planning board submission package. We appreciate your time and consideration to this matter.

Sincerely,

Mark Masse
Senior Vice President of Operations
Genesee County Industrial Development
Agency d/b/a Genesee County Economic
Development Center

Appendix M

Project Drawings

